

Single-Phase Voltage Regulator

High Efficiency, Integrated Power MOSFETs



ON Semiconductor®

www.onsemi.com

NCP3284

The NCP3284, a single-phase synchronous buck regulator, integrates power MOSFETs to provide a high-efficiency and compact-footprint power management solution. The NCP3284 is able to deliver up to 30 A TDC output current on a wide output voltage range. Operating in high switching frequency up to 1 MHz allows employing small size inductors and capacitors while maintaining high efficiency due to integrated solution with high performance power MOSFETs. It provides differential voltage sense, flexible soft-start programming, and comprehensive protections.

Features

- $V_{in} = 4.5\text{ V} \sim 18\text{ V}$ with Input Feedforward
- $V_{out} = 0.8\text{ V} \sim \text{Min}(0.85 \times V_{in}, 5.5\text{ V})$ with Remote Voltage Sense
- $f_{sw} = 500\text{k}/600\text{k}/800\text{k}/1\text{ MHz}$ Switching Frequency
- Up to 30 A Continuous Output Current and 45 A Pulse Current
- Integrated 5 V LDO or External 5 V Supply
- Enable with Programmable V_{in} UVLO
- Selectable Forced CCM and Auto DCM/CCM for High Efficiency at Light Load
- Programmable Soft Start
- Output Discharge in Shutdown
- Programmable Current Limit
- Under-Voltage Protection and Over-Voltage Protection
- Recoverable Thermal Shutdown Protection
- Selectable Protection Mode (Latch-off or Hiccup)
- Power Good Indicator
- PQFN37, 5x6 mm, 0.5 mm Pitch Package
- This Device is Pb-Free and is RoHS Compliant

Typical Applications

- Point of Load
- Telecom and Networking
- Server and Storage System
- Computing Applications

MARKING DIAGRAM

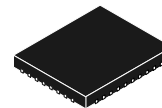

PQFN37 5x6, 0.5P
CASE 483BZ

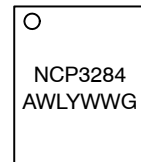

A = Assembly Site
WL = Wafer Lot Number
Y = Year of Production
WW = Work Week Number
G = Pb-Free Designator

PINOUT

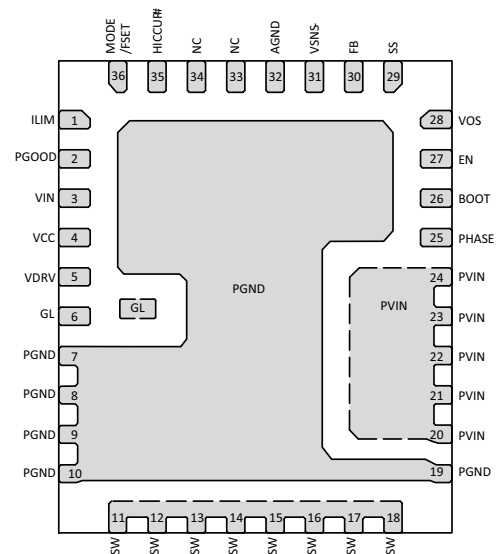

(Top View)

ORDERING INFORMATION

Device	Package	Shipping†
NCP3284MNTXG	PQFN37 (Pb-Free)	2500 / Tape & Reel

†For information on tape and reel specifications, including part orientation and tape sizes, please refer to our Tape and Reel Packaging Specification Brochure, BRD8011/D.

NCP3284

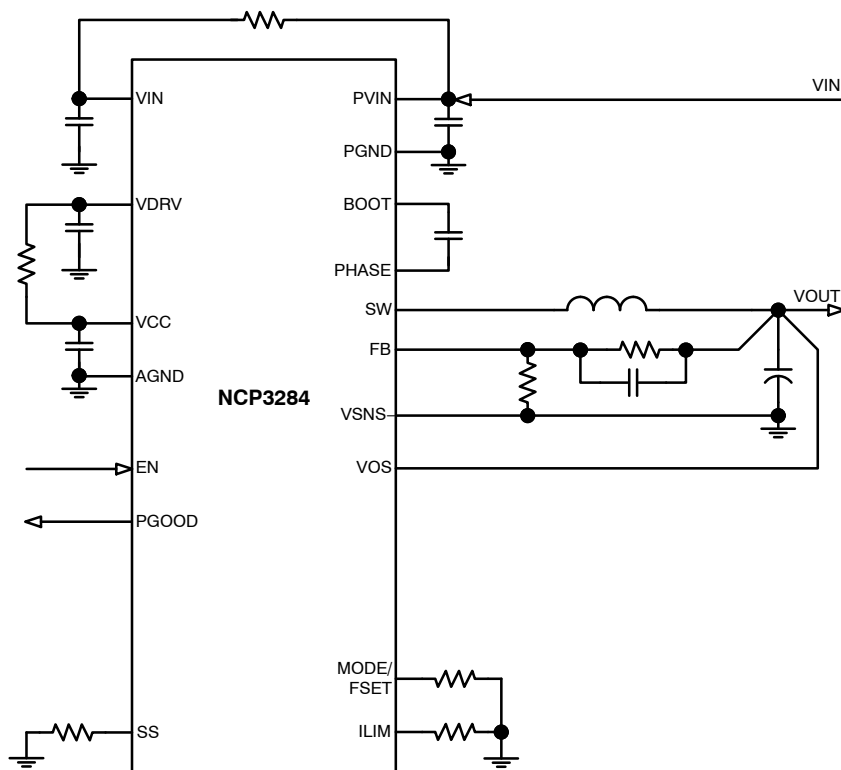

Figure 1. Typical Application Circuit with Single Input Power Supply (LDO Enabled)

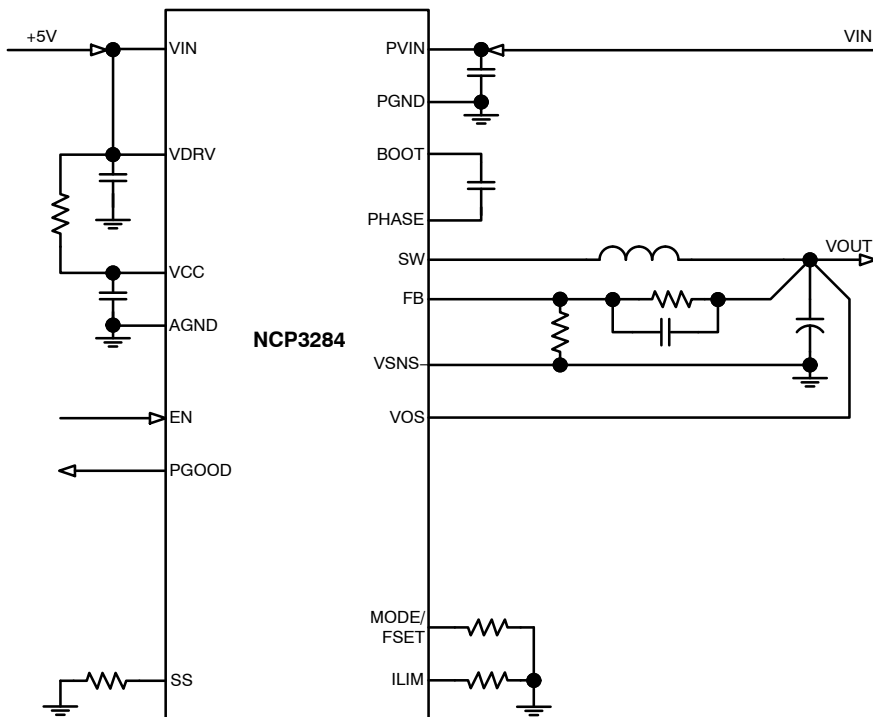

Figure 2. Typical Application Circuit with External 5 V Supply for VCC (LDO Disabled)

NCP3284

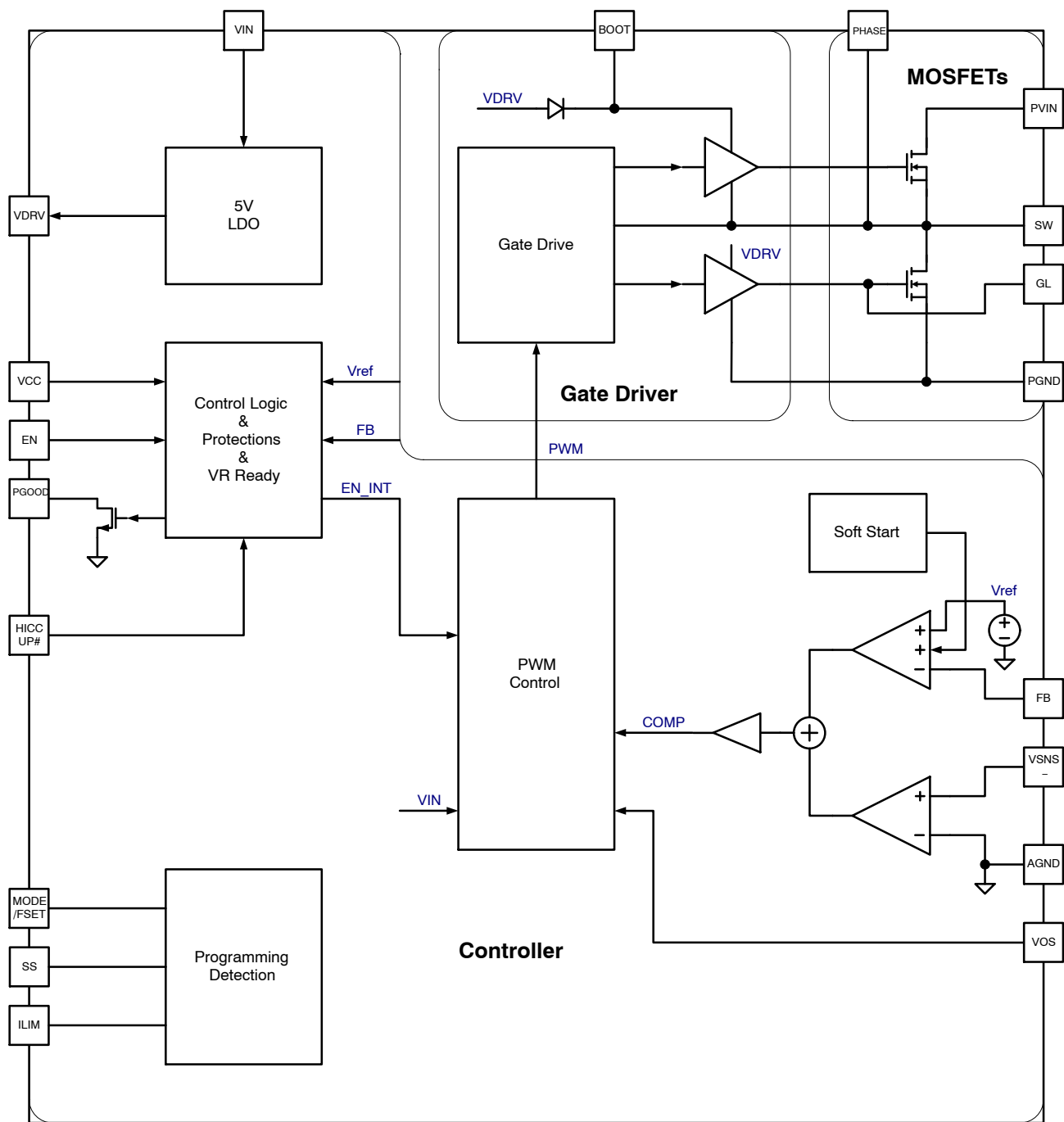

Figure 3. Functional Block Diagram

NCP3284

PIN DESCRIPTION

Pin	Name	Type	Description
1	ILIM	Analog Output	Current Limit. A resistor between this pin and AGND to program current limit.
2	PGOOD	Logic Output	Power GOOD. Open-drain output. Provides a logic high valid power good output signal, indicating the regulator's output is in regulation window.
3	VIN	Power Input	Power Supply Input of LDO. Power supply input pin of internal 5 V LDO. A 1.0 μ F or more ceramic capacitors must bypass this input to power ground. The capacitors should be placed as close as possible to this pin. A direct short from this pin to VDRV (pin 5) disables the internal LDO for applications with an external 5 V supply as power of VDRV and VCC.
4	VCC	Analog Power	Supply Voltage Input of Controller. A 2.2 μ F or larger ceramic capacitor bypasses this input to GND. This capacitor should be placed as close as possible to this pin.
5	VDRV	Analog Power	Output of LDO and Supply Voltage Input of Gate Drivers. Output of integrated 5.0 V LDO and power supply input of gate drivers. A 4.7 μ F/25 V or larger ceramic capacitor bypasses this pin to PGND. The capacitor should be placed as close as possible to this pin.
6	GL	Analog Output	Gate of Low-Side MOSFET. Directly connected with the gate of the low-side power MOSFET.
7~10,19	PGND	Power Ground	Power Ground. These pins are the power supply ground pins of the device, which are connected to source of internal low-side power MOSFET. Must be connected to the system ground.
11~18	SW	Power Bidirectional	Switch Node. Pins to be connected to an external inductor. These pins are interconnection between internal high-side MOSFET and low-side MOSFET.
20~24	PVIN	Power Input	Power Supply Input. These pins are the power supply input pins of the device, which are connected to drain of internal high-side power MOSFET. A 22 μ F or more ceramic capacitors must bypass this input to PGND. The capacitors should be placed as close as possible to these pins.
25	PHASE	Power Return	Phase Node. Provides a return path for integrated high-side gate driver. It is internally connected to source of high-side MOSFET.
26	BOOT	Power Bidirectional	Bootstrap. Provides bootstrap voltage for high-side gate driver. A 0.22 μ F/25 V ceramic capacitor is required from this pin to PHASE (pin 25).
27	EN	Logic Input	Enable. Logic high enables controller while logic low disables controller. Input supply UVLO can be programmed at this pin.
28	VOS	Analog Input	Voltage Sense. Direct voltage sense for output voltage feedforward.
29	SS	Analog Input	Soft Start. A resistor between this pin and GND to program the soft-start slew rate and options.
30	FB	Analog Input	Feedback. Inverting input to error amplifier.
31	VSNS-	Analog Input	Voltage Sense Negative Input. Connect this pin to remote voltage negative sense point.
32	AGND	Analog Ground	Analog Ground. Ground of controller. Must be connected to the system ground.
33~34	NC	-	No Connection.
35	HICCUP#	Analog Input	Latch-Off / Hiccup#. Float this pin to enable latch-off mode in protections (OCP/ UVP/OVP); Ground this pin to ground to enable hiccup mode in protections.
36	MODE/FSET	Analog Input	Mode and Frequency Set. A resistor between this pin and AGND to program operation mode and nominal switching frequency.

NCP3284

MAXIMUM RATINGS

Rating	Symbol	Value		Unit
		MIN	MAX	
Power Supply Voltage to PGND	V_{PVIN}, V_{VIN}		23	V
PHASE/SW to PGND	V_{PHASE}, V_{SW}	-0.6 -5 (<50 ns)	23 25 (<10 ns)	V
Driver Supply Voltage to PGND	V_{VDRV}	-0.3	5.5	V
Analog Supply Voltage to AGND	V_{VCC}	-0.3	6.5	V
BOOT to PGND	BOOT_PGND	-0.3	30 33 (<50 ns)	V
BOOT to PHASE/SW	BOOT_PHASE/SW	-0.3	6.5	V
GL to PGND	GL	-0.3 -2 (<200 ns)	VDRV+0.3	V
VSNS- to AGND	VSNS-	-0.2	0.2	V
PGND to AGND	PGND	-0.3	0.3	V
Other Pins		-0.3	VCC+0.3	V
Human Body Model (HBM) ESD Rating are (Note 1)	ESD HBM		2000	V
Charge Device Model (CDM) ESD Rating are (Note 1)	ESD CDM		2000	V
Latch up Current: (Note 2)	I_{LU}	-100	100	mA
Operating Junction Temperature Range	T_J	-40	125	°C
Operating Ambient Temperature Range	T_A	-40	100	°C
Storage Temperature Range	T_{STG}	-55	150	°C
Thermal Resistance Junction to Top Case(Note 3)	$R_{\Psi JC}$		0.8	°C/W
Thermal Resistance Junction to Board (Note 3)	$R_{\Psi JB}$		0.9	°C/W
Thermal Resistance Junction to Ambient (Note 3)	$R_{\theta JA}$		26.7	°C/W
Maximum Power Dissipation (Note 4)	P_D		3.75	W
Moisture Sensitivity Level (Note 5)	MSL		1	-

Stresses exceeding those listed in the Maximum Ratings table may damage the device. If any of these limits are exceeded, device functionality should not be assumed, damage may occur and reliability may be affected.

1. This device is ESD sensitive. Handling precautions are needed to avoid damage or performance degradation.
2. Latch up Current per JEDEC standard: JEDEC78 class II.
3. The thermal resistance values are dependent of the internal losses split between devices and the PCB heat dissipation. This data is based on a typical operation condition with a 4-layer FR-4 PCB board, which has two, 1-ounce copper internal power and ground planes and 2-ounce copper traces on top and bottom layers with approximately 80% copper coverage. No airflow and no heat sink applied (reference EIA/JEDEC 51.7). It also does not account for other heat sources that may be present on the PCB next to the device in question (such as inductors, resistors etc.)
4. The maximum power dissipation (P_D) is dependent on input voltage, output voltage, output current, external components selected, and PCB layout. The reference data is obtained based on $T_{JMAX} = 125^\circ\text{C}$ and $T_A = 25^\circ\text{C}$.
5. Moisture Sensitivity Level (MSL): IPC/JEDEC standard: J-STD-020A.

NCP3284

ELECTRICAL CHARACTERISTICS ($V_{IN} = 12\text{ V}$, typical values are referenced to $T_A = T_J = 25^\circ\text{C}$, Min and Max values are referenced to $T_A = T_J = -40^\circ\text{C}$ to 125°C , unless other noted.)

Characteristics	Test Conditions	Symbol	MIN	TYP	MAX	UNITS
-----------------	-----------------	--------	-----	-----	-----	-------

SUPPLY VOLTAGE MONITOR

VCC Under-Voltage (UVLO) Threshold	VCC falling	V_{DDUV-}	4.0			V
VCC OK Threshold	VCC rising	V_{DDOK}			4.5	V
VCC UVLO Hysteresis		V_{DDHYS}		200		mV

SUPPLY CURRENT

PVIN Shutdown Current	EN low	I_{SDPVIN}	-	4.8	20	μA	
V_{IN} Quiescent Supply Current (VCC Current Included)	EN high, no switching	LDO enabled, $V_{IN} = 18\text{ V}$, $V_{CC} = V_{DRV}$	I_{QVIN}	-	3.5	6.4	mA
		LDO disabled, $V_{IN} = V_{DRV} = V_{CC} = 4.5\text{ V}$		-	3.5	6.4	
V_{IN} Shutdown Current (VCC Current Included)	EN low $T_A = T_J = 25^\circ\text{C}$	LDO enabled, $V_{IN} = 18\text{ V}$, $V_{CC} = V_{DRV}$	I_{SDVIN}	-	42	60	μA
		LDO disabled, $V_{IN} = V_{DRV} = V_{CC} = 4.5\text{ V}$		-	63	150	

5V Linear Regulator

Output Voltage	$6\text{ V} < V_{IN} < 18\text{ V}$, $I_{DRV} = 0$ to 30 mA (External) EN high, no switching	V_{DRV}	4.8	5.07	5.4	V
Dropout Voltage	$V_{IN} = 5\text{ V}$, $I_{DRV} = 50\text{ mA}$ (External), EN high, no switching	V_{DO}			200	mV

PWM MODULATION

Minimum On Time	(Note 6)	T_{on_min}		50		ns
Minimum Off Time	(Note 6)	T_{off_min}		150		ns

VOLTAGE REGULATION

Regulated Feedback Voltage	FB to V_{SNS-}	V_{FB}	795	800	805	mV
----------------------------	------------------	----------	-----	-----	-----	----

VOLTAGE ERROR AMPLIFIER

FB, V_{SNS-} Bias Current	$V_{FB} = V_{V_{SNS-}} = 1.0\text{ V}$	I_{FB}	-50		50	nA
-----------------------------	----------------------------------------	----------	-----	--	----	----

CURRENT-SENSE AMPLIFIER

Closed-Loop DC Gain		$GAIN_{CA}$		-10		V/V
-3 dB Gain Bandwidth	(Note 6)	BW_{CA}		10		MHz
Input Offset Voltage	$V_{osCS} = V_{SW} - V_{PGND}$ (Note 6)	V_{osCS}	-500	-	500	μV
ENABLE						
EN ON Threshold		V_{EN_TH}	1.32	1.43	1.54	V
Hysteresis Resistance		R_{HYS}		40		k Ω
Hysteresis Current		I_{EN_HYS}		5.4		μA
EN Input Leakage Current	EN = 5 V	I_{EN_LK}			1.0	μA

SWITCHING FREQUENCY

Switching Frequency in CCM	1% Resistor from MODE/FSET Pin to AGND, $V_{out} = 5\text{ V}$ (Note 6)	2.49k or 14.0k	F_{SW}		1000		kHz
		12.1k or float			800		
		0 or 10.5k			600		
		4.99k or 7.50k			500		
Source Current from Mode/FSET Pin		I_{FSET}	45	50	55	μA	

NCP3284

ELECTRICAL CHARACTERISTICS ($V_{IN} = 12\text{ V}$, typical values are referenced to $T_A = T_J = 25^\circ\text{C}$, Min and Max values are referenced to $T_A = T_J = -40^\circ\text{C}$ to 125°C , unless other noted.)

Characteristics	Test Conditions	Symbol	MIN	TYP	MAX	UNITS
-----------------	-----------------	--------	-----	-----	-----	-------

SOFT START

System Reset Time	Measured from EN to start of soft start	T_{RST}		0.7		ms
Soft Start Time	1% Resistor from SS Pin to AGND	0 or 4.53k	T_{SS}	1		ms
		1.5k or 5.76k		2		
		12.1k or float		4		
		3.48k or 8.87k		8		
Source Current from SS Pin		I_{SS}	45	50	55	μA

PGOOD

PGOOD Shutdown Delay	From EN to PGOOD de-assertion (Note 6)			1.0		μs
PGOOD Low Voltage	$I_{PGOOD} = 4\text{ mA Sink}$	V_{IPGOOD}			0.3	V
PGOOD Leakage Current	PGOOD = 5 V	$I_{IKPGOOD}$			1.0	μA

PROTECTIONS

Valley Current Limit Threshold	$T_A = T_J = 25^\circ\text{C}$ (Note 6)	$R_{LIM} = 24.9\text{ k}\Omega$	I_{OC}		39		A
		$R_{LIM} = 21.5\text{ k}\Omega$			33		
		$R_{LIM} = 16.2\text{ k}\Omega$			26		
		$R_{LIM} = 12.1\text{ k}\Omega$			19		
Current Limit Temperature Coefficient	(Note 6)			-5900		ppm/ $^\circ\text{C}$	
Fast Under Voltage Protection (FUVF) Threshold	FB to AGND		0.15	0.2	0.25	V	
Fast Under Voltage Protection (FUVF) Delay	(Note 6)			1.0		μs	
Slow Under Voltage Protection (SUVF) Threshold	COMP to GND (Note 6)			3.0		V	
Slow Under Voltage Protection (SUVF) Delay	(Note 6)			50		μs	
Over Voltage Threshold	FB rising		0.95	1.0	1.05	V	
Over Voltage Protection Hysteresis	FB falling (Note 6)			-10		mV	
Over Voltage Debounce Time	FB rising to GL high			1.0		μs	
Hiccup Idle Time	Pin 35 is grounded (Note 6)			32		ms	
Thermal Shutdown (TSD) Threshold	(Note 6)	T_{SD}	140	150		$^\circ\text{C}$	
Recovery Temperature Threshold	(Note 6)	T_{rec}		125		$^\circ\text{C}$	
Thermal Shutdown (TSD) Debounce Time	(Note 6)			50		ns	

Product parametric performance is indicated in the Electrical Characteristics for the listed test conditions, unless otherwise noted. Product performance may not be indicated by the Electrical Characteristics if operated under different conditions.

6. Guaranteed by design, not tested in production.

NCP3284

DETAILED DESCRIPTION

General

The NCP3284, a single-phase synchronous buck regulator, integrates power MOSFETs to provide a high-efficiency and compact-footprint power management solution. The NCP3284 is able to deliver up to 30 A TDC output current on a wide output voltage range. Operating in high switching frequency up to 1 MHz allows employing small size inductors and capacitors while maintaining high efficiency due to integrated solution with high performance

power MOSFETs. It provides differential voltage sense, flexible soft-start programming, and comprehensive protections.

Operation Modes

Operation mode and switching frequency are programmed at MODE/FSET pin with a $\pm 1\%$ tolerance resistor as shown in Table 1.

Table 1. MODE AND SWITCHING FREQUENCY CONFIGURATION

Resistance @ MODE/FSET Pin (Ω , $\pm 1\%$)	Frequency (kHz)	Operation Mode
0	600	FCCM
2.49k	1000	FCCM
4.99k	500	Auto CCM/DCM
7.5k	500	FCCM
10.5k	600	Auto CCM/DCM
12.1k	800	Auto CCM/DCM
14.0k	1000	Auto CCM/DCM
Float	800	FCCM

Current-Mode RPM Operation

The NCP3284 operates with the current-mode Ramp-Pulse-Modulation (RPM) scheme. In Forced CCM mode, the inductor current is always continuous and the device operates in quasi-fixed switching frequency, which has a typical value programmed by users through a resistor at pin MODE/FSET. In Auto CCM/DCM mode, the

inductor current is continuous and the device operates in quasi-fixed switching frequency in medium and heavy load range, while the inductor current becomes discontinuous and the device automatically operates in PFM mode with an adaptive fixed on time and variable switching frequency in light load range.

NCP3284

Soft Start and Shut Down

The NCP3284 has a soft start function which also operates well under a pre-biased output condition. The NCP3284's soft start time is externally programmed at SS pins. The output starts to ramp up following a system reset period

T_{RST} , 0.7 ms typical, after the device is enabled. When the device is disabled or UVLO happens, the device shuts down immediately and both high-side and low-side MOSFETs are off. A timing diagram of power up/down is shown in Figure 4.

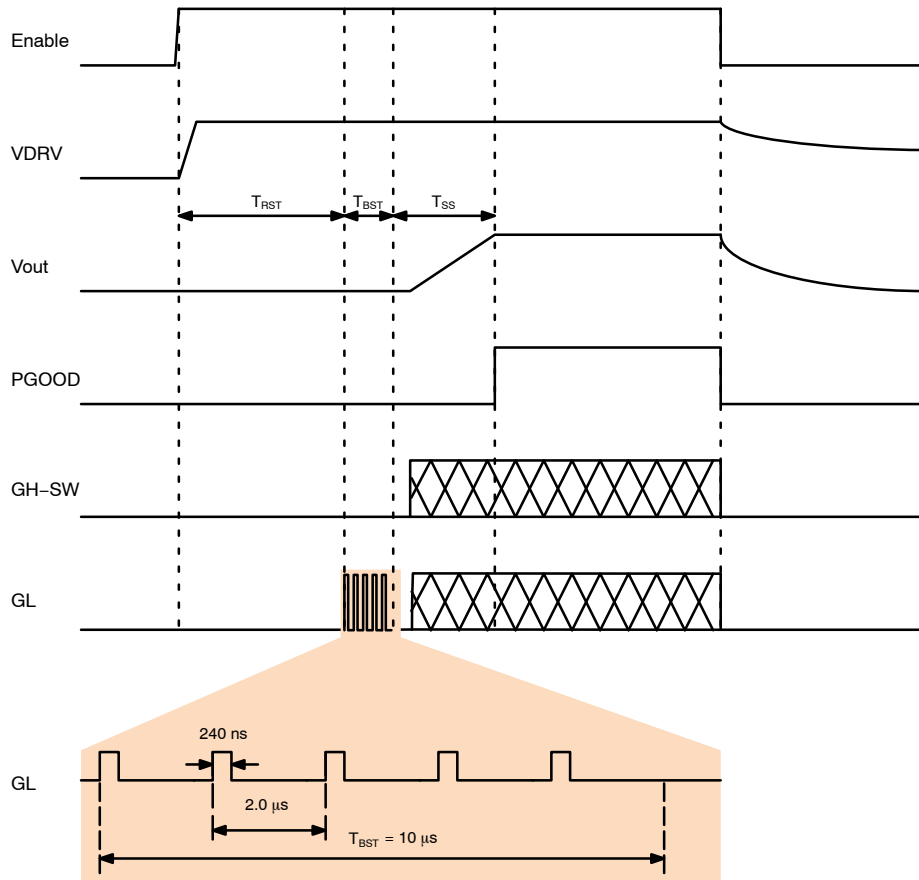

Figure 4. Timing Diagram of Power Up/Down Sequence

Bootstrap Capacitor Voltage Refreshing

In the NCP3284, a bootstrap circuit is employed to provide supply voltage for high-side gate driver. An external 0.22 μF/25 V ceramic capacitor is connected between BOOT pin and PHASE pin to hold up the bootstrap voltage. In order to charge up this capacitor just before a soft start, 5 consecutive pulses are sent to GL, gate of the low-side MOSFET, as shown in Figure 4.

In forced CCM mode, the bootstrap voltage is refreshed cycle-by-cycle and always fully charged. However, a

special care needs to be taken in applications with $V_{out} \geq 1.8 V$ and auto DCM/CCM mode enabled. To make sure the bootstrap capacitor has an enough voltage level for proper operation of high-side gate driver, there is a minimum load requirement to limit the minimum switching frequency not to go below 2 kHz. For a typical 5 V output application with auto DCM/CCM mode enabled, the minimum load current may need to be higher than 2 mA.

Enable and Input UVLO

The NCP3284 is enabled when the voltage at EN pin is higher than a summing voltage level of an internal threshold V_{EN_TH} and a hysteresis. The hysteresis can be programmed by an external resistor R_{EN} connected to EN pin as shown in Figure 5. The high threshold V_{EN_H} in ENABLE signal is

$$V_{EN_H} = V_{EN_TH} + V_{EN_HYS} \quad (\text{eq. 1})$$

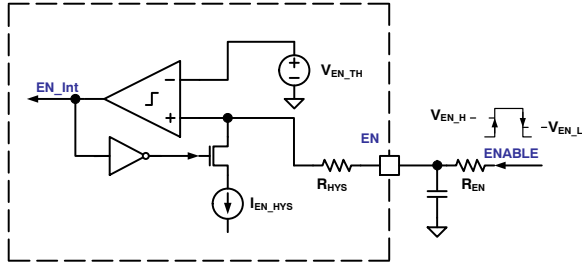

Figure 5. Enable and Hysteresis Programming

The low threshold V_{EN_L} in ENABLE signal is

$$V_{EN_L} = V_{EN_TH} \quad (\text{eq. 2})$$

The hysteresis V_{EN_HYS} is

$$V_{EN_HYS} = I_{EN_HYS} \times (R_{HYS} + R_{EN}) \quad (\text{eq. 3})$$

A UVLO function for input power supply can be implemented at EN pin. As shown in Figure 6, the UVLO threshold can be programmed by two external resistors. The low threshold V_{IN_L} in V_{IN} signal is

$$V_{IN_L} = \left(\frac{R_{EN1}}{R_{EN2}} + 1 \right) \times V_{EN_TH} \quad (\text{eq. 4})$$

The high threshold V_{IN_H} in V_{IN} signal is

$$V_{IN_H} = V_{IN_L} + V_{IN_HYS} \quad (\text{eq. 5})$$

The hysteresis V_{IN_HYS} is

$$V_{IN_HYS} = I_{EN_HYS} \times \left(R_{HYS} \left(1 + \frac{R_{EN1}}{R_{EN2}} \right) + R_{EN1} \right) \quad (\text{eq. 6})$$

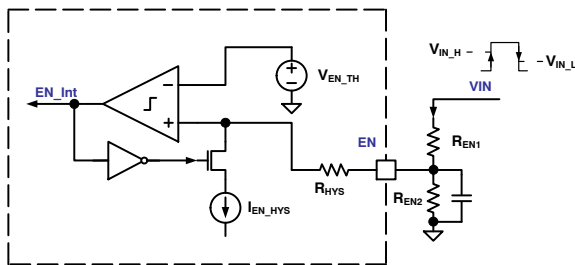

Figure 6. Enable and Input Supply UVLO Circuit

To avoid undefined operation, EN pin should not be left float in applications.

Over Current Protection (OCP)

The NCP3284 protects converter from over current by a cycle-by-cycle current limitation. The average current limit

ILMT can be calculated from the programmed valley current limit I_{LMT_Valley} and inductor current ripple.

$$I_{LMT} = I_{LMT_Valley} + \frac{V_o \times (V_{IN} - V_o)}{2 \times V_{in} \times L \times F_{SW}}$$

$$= 1.5412 \times R_{Ilim} + \frac{V_o \times (V_{IN} - V_o)}{2 \times V_{in} \times L \times F_{SW}} \quad (\text{eq. 7})$$

where R_{Ilim} is resistance of the programming resistor at ILIM pin, V_{IN} is input voltage, V_o is output voltage, L is filter inductance, and F_{SW} is nominal switching frequency.

OCP detection starts from the beginning of soft-start time T_{SS} , and it ends in shutdown, latch-off, and hiccup idle time. The inductor current is monitored by voltage sensing between SW pin and PGND pin. If over current happens and lasts for more than 50 μs , the device turns to either latch-off or hiccup. The device may enter into under voltage protection before OCP latch-off/hiccup happens if the output voltage drops down very fast.

Under Voltage Protection (UVP)

UVP detection starts when PGOOD delay T_{d_PGOOD} is expired right after a soft start, and it ends in shutdown, latch-off, and hiccup idle time. The NCP3284 pulls PGOOD low and turns off both high-side and low-side MOSFETs once FB voltage drops below 0.2 V for more than 1.0 μs .

Over Voltage Protection (OVP)

OVP detection starts from the beginning of soft-start time T_{SS} , and it ends in shutdown, latch-off, and hiccup idle time. During normal operation the output voltage is monitored at FB pin. If FB voltage exceeds the OVP threshold for more than 1 μs , OVP is triggered and PGOOD is pulled low. In the meanwhile, the high-side MOSFET is latched off and the low-side MOSFET is turned on. After the OVP trips, the DAC ramps slowly down to zero, having a negative slew rate as the same value of soft start to reduce negative output voltage spike. The low-side MOSFET toggles between on and off as the output voltage follows the DAC ramping down. After the DAC gets to zero, the high-side MOSFET holds off and the low-side MOSFET keeps on.

Latch-Off or Hiccup in Protections

The NCP3284 can be configured to have either latch-off mode or hiccup mode, for the protections (OCP, UVP, and OVP), by means of leaving pin 35 float or shorting it to ground.

To restart the device after latch-off, the system needs to have either VCC or EN toggled state and then a normal power-up sequence follows including system reset and auto calibration.

If hiccup mode is selected, the NCP3284 starts to count idle time of 32 ms once PGOOD is pulled low due to any of the protections. After the end of the hiccup idle time, a normal power up sequence happens including system reset and auto calibration.

Thermal Shutdown (TSD)

The NCP3284 has an internal thermal shutdown protection to protect the device from overheating in an extreme case that the die temperature exceeds 150°C. TSD detection is activated when VCC and EN are valid. Once the thermal protection is triggered, the whole chip shuts down. If the temperature drops below 125°C, the system automatically recovers and a normal power-up sequence follows.

Power Good (PGOOD)

PGOOD is asserted in normal operation after soft start ends, and it is pulled low in protections and shutdown. PGOOD pin is an open-drain pin and its internal pull-down control circuit is powered by VCC. To avoid an invalid PGOOD indication when VCC is not ready, it is recommended to have the external pull-up resistor at PGOOD pin to be connected to either VCC or an external voltage source which always keeps not being higher than VCC level.

LAYOUT GUIDELINES

Electrical Layout Considerations

Good electrical layout is a key to make sure proper operation, high efficiency, and noise reduction. Electrical layout guidelines are:

- *Power Paths:* Use wide and short traces for power paths (such as VIN, VOUT, SW, and PGND) to reduce parasitic inductance and high-frequency loop area. It is also good for efficiency improvement
- *Power Supply Decoupling:* The device should be well decoupled by input capacitors and input loop area should be as small as possible to reduce parasitic inductance, input voltage spike, and noise emission. Usually, a small low-ESL MLCC is placed very close to PVIN and PGND pins

- *VCC Decoupling:* Place decoupling caps as close as possible to the controller VCC and VDRV pins. The filter resistor at VCC pin should be not higher than 2.2 Ω to prevent large voltage drop
- *Switching Node:* SW node should be a copper pour, but compact because it is also a noise source
- *Bootstrap:* The bootstrap cap and an option resistor need to be very close and directly connected between pin 26 (BST) and pin 25 (PHASE). No need to externally connect pin 25 to SW node because it has been internally connected to other SW pins
- *Ground:* It would be good to have multiple layers of GND planes on PCB. Directly connect the exposed PGND pad to GND planes through multiple vias. Connect AGND pin to GND planes through a via close to the pin
- *Voltage Sense:* Use Kelvin sense pair and arrange a “quiet” path for the differential output voltage sense. Keep the FB trace short to minimize its capacitance to ground

Thermal Layout Considerations

Good thermal layout helps high power dissipation from a small package with reduced temperature rise. Thermal layout guidelines are:

- The exposed pads must be well soldered on the board
- A four or more layers PCB board with solid ground planes is preferred for better heat dissipation
- More free vias are welcome to be around IC and underneath the exposed pads to connect the inner ground layers to reduce thermal impedance
- Use large area copper pour to help thermal conduction and radiation
- Do not put the inductor to be too close to the IC, thus the heat sources are distributed

ON Semiconductor and  are trademarks of Semiconductor Components Industries, LLC dba ON Semiconductor or its subsidiaries in the United States and/or other countries. ON Semiconductor owns the rights to a number of patents, trademarks, copyrights, trade secrets, and other intellectual property. A listing of ON Semiconductor's product/patent coverage may be accessed at www.onsemi.com/site/pdf/Patent-Marking.pdf. ON Semiconductor reserves the right to make changes without further notice to any products herein. ON Semiconductor makes no warranty, representation or guarantee regarding the suitability of its products for any particular purpose, nor does ON Semiconductor assume any liability arising out of the application or use of any product or circuit, and specifically disclaims any and all liability, including without limitation special, consequential or incidental damages. Buyer is responsible for its products and applications using ON Semiconductor products, including compliance with all laws, regulations and safety requirements or standards, regardless of any support or applications information provided by ON Semiconductor. "Typical" parameters which may be provided in ON Semiconductor data sheets and/or specifications can and do vary in different applications and actual performance may vary over time. All operating parameters, including "Typicals" must be validated for each customer application by customer's technical experts. ON Semiconductor does not convey any license under its patent rights nor the rights of others. ON Semiconductor products are not designed, intended, or authorized for use as a critical component in life support systems or any FDA Class 3 medical devices or medical devices with a same or similar classification in a foreign jurisdiction or any devices intended for implantation in the human body. Should Buyer purchase or use ON Semiconductor products for any such unintended or unauthorized application, Buyer shall indemnify and hold ON Semiconductor and its officers, employees, subsidiaries, affiliates, and distributors harmless against all claims, costs, damages, and expenses, and reasonable attorney fees arising out of, directly or indirectly, any claim of personal injury or death associated with such unintended or unauthorized use, even if such claim alleges that ON Semiconductor was negligent regarding the design or manufacture of the part. ON Semiconductor is an Equal Opportunity/Affirmative Action Employer. This literature is subject to all applicable copyright laws and is not for resale in any manner.

PUBLICATION ORDERING INFORMATION

LITERATURE FULFILLMENT:

Literature Distribution Center for ON Semiconductor
19521 E. 32nd Pkwy, Aurora, Colorado 80011 USA
Phone: 303-675-2175 or 800-344-3860 Toll Free USA/Canada
Fax: 303-675-2176 or 800-344-3867 Toll Free USA/Canada
Email: orderlit@onsemi.com

N. American Technical Support: 800-282-9855 Toll Free
USA/Canada
Europe, Middle East and Africa Technical Support:
Phone: 421 33 790 2910

ON Semiconductor Website: www.onsemi.com

Order Literature: <http://www.onsemi.com/orderlit>

For additional information, please contact your local
Sales Representative