

Low Quiescent Current, Programmable Delay Time, Supervisory Circuit

NCP308, NCV308

The NCP308 series is one of the ON Semiconductor Supervisory circuit IC families. It is optimized to monitor system voltages from 0.405 V to 5.5 V, asserting an active low open-drain $\overline{\text{RESET}}$ output, together with Manual Reset ($\overline{\text{MR}}$) Input. The part comes with both fixed and externally adjustable versions.

Features

- Wide Supply Voltage Range 1.6 to 5.5 V
- Very Low Quiescent Current 1.6 μA
- Fixed Threshold Voltage Versions for Standard Voltage Rails Including 0.9 V, 1.2 V, 1.25 V, 1.5 V, 1.8 V, 1.9 V, 2.5 V, 2.8 V, 3.0 V, 3.3 V, 5.0 V
- Adjustable Version with Low Threshold Voltage 0.405 V (min)
- High Threshold Voltage Accuracy: 0.31% typ
- Support Manual Reset Input ($\overline{\text{MR}}$)
- Open-Drain $\overline{\text{RESET}}$ Output (Push-pull Output upon Request)
- Flexible Delay Time Programmability: 1.25 ms to 10 s
- Temperature Range: -40°C to $+125^{\circ}\text{C}$
- Small TSOP-6 and WDFN6 2 x 2 mm, Pb-Free packages
- NCV Prefix for Automotive and Other Applications Requiring Unique Site and Control Change Requirements; AEC-Q100 Qualified and PPAP Capable
- These are Pb-Free Devices

Typical Applications

- DSP or Microcontroller Applications
- Notebook/Desktop Computers
- PDAs/Hand-Held Products
- Portable/Battery-Powered Products
- FPGA/ASIC Applications

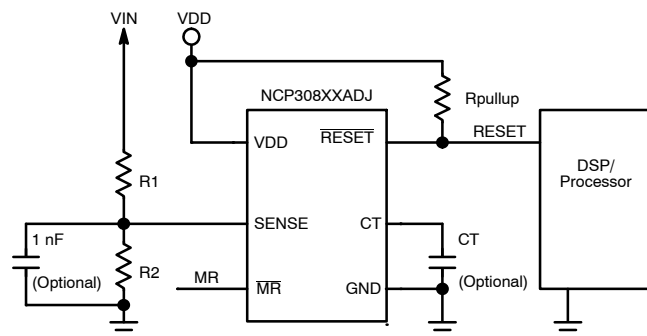

Figure 1. Typical Application Circuit for Adjustable Versions

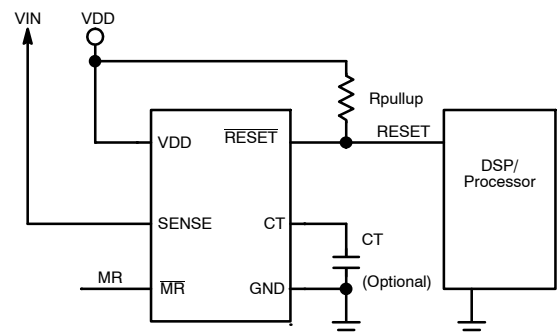

Figure 2. Typical Application Circuit for Fixed Versions



ON Semiconductor®

www.onsemi.com

MARKING DIAGRAMS



TSOP-6
CASE 318G

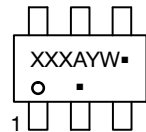

WDFN6
CASE 511BR

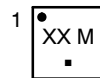

XXX, XX= Specific Device Code
A = Assembly Location
Y = Year
W = Work Week
M = Date Code
▪ = Pb-Free Package

(Note: Microdot may be in either location)

ORDERING INFORMATION

See detailed ordering and shipping information in the ordering information section on page 9 of this data sheet.

NCP308, NCV308

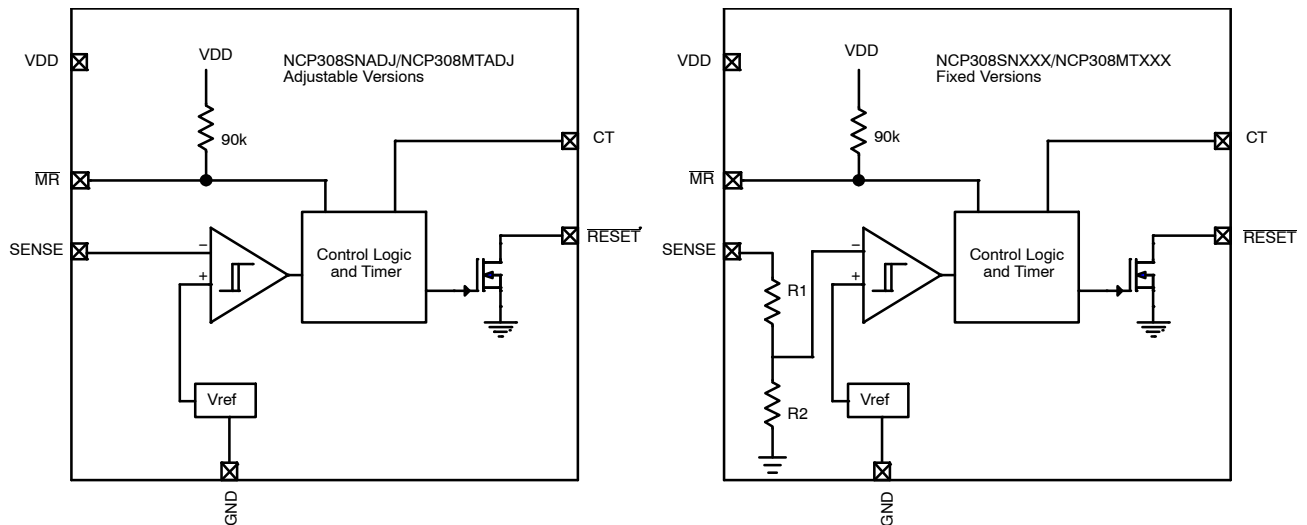

Figure 3. Functional Block Diagrams of Adjustable and Fixed Versions

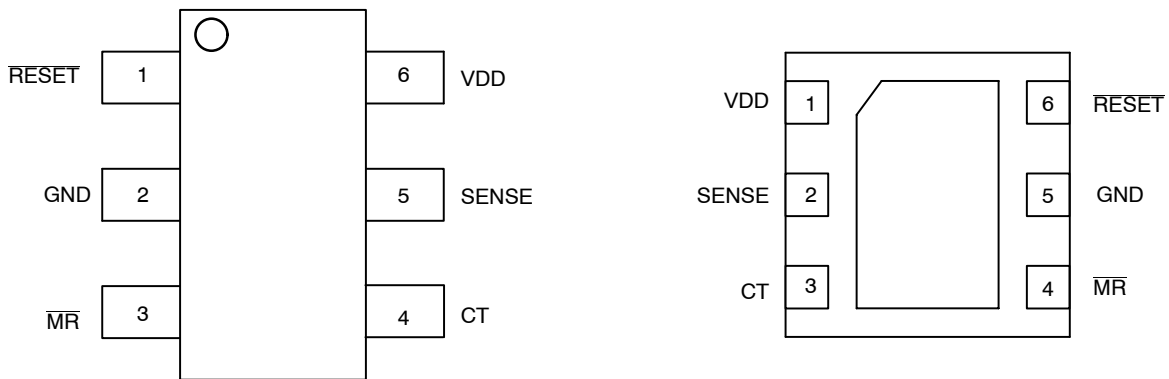

Figure 4. Pin Connections Diagram (Top View)

Table 1. PIN OUT DESCRIPTION

Name	Pin Number		Description
	TSOP-6	WDFN6	
VDD	6	1	Supply Voltage. A 0.1 μ F ceramic capacitor placed close to this pin is helpful for transient and parasitic.
SENSE	5	2	Sense Input, this is the voltage to be monitored. If the voltage at this terminal drops below the threshold voltage V_{IT} , then RESET is asserted. SENSE does not necessary monitor VDD, it can monitor any voltage lower than VDD.
CT	4	3	Reset Delay Time Setting Pin. Connecting this pin to VDD through a 40 k Ω to 200 k Ω resistor or leaving it open results in fixed reset delay times. Connecting this pin to a ground referenced capacitor (≥ 100 pF) gives a user-programmable reset delay time. See the <i>Setting Reset Delay Time</i> section for more information.
\overline{MR}	3	4	Manual Reset input, \overline{MR} low asserts RESET. \overline{MR} is internally tied to VDD by a 90 k Ω pull-up Resistor.
RESET	1	6	RESET Output, is an Active low open drain N-Channel MOSFET output, it is driven to a low impedance state when RESET is asserted (either the SENSE input is lower than the threshold voltage (V_{IT}) or the \overline{MR} pin is set to a logic low). RESET will keep low (asserted) for the reset delay time after both SENSE is above V_{IT} and \overline{MR} is set to a logic high. A pull-up resistor from 10k Ω to 1M Ω should be used on this pin. See Figure 5 for behavior of RESET depends on VDD, SENSE and \overline{MR} conditions.
GND	2	5	Ground terminal. Should be connected to PCB ground reference
EXP PAD	-	Exposed Pad	Exposed pad, under WDFN6 package, connect it to ground plane for better thermal dissipation.

NCP308, NCV308

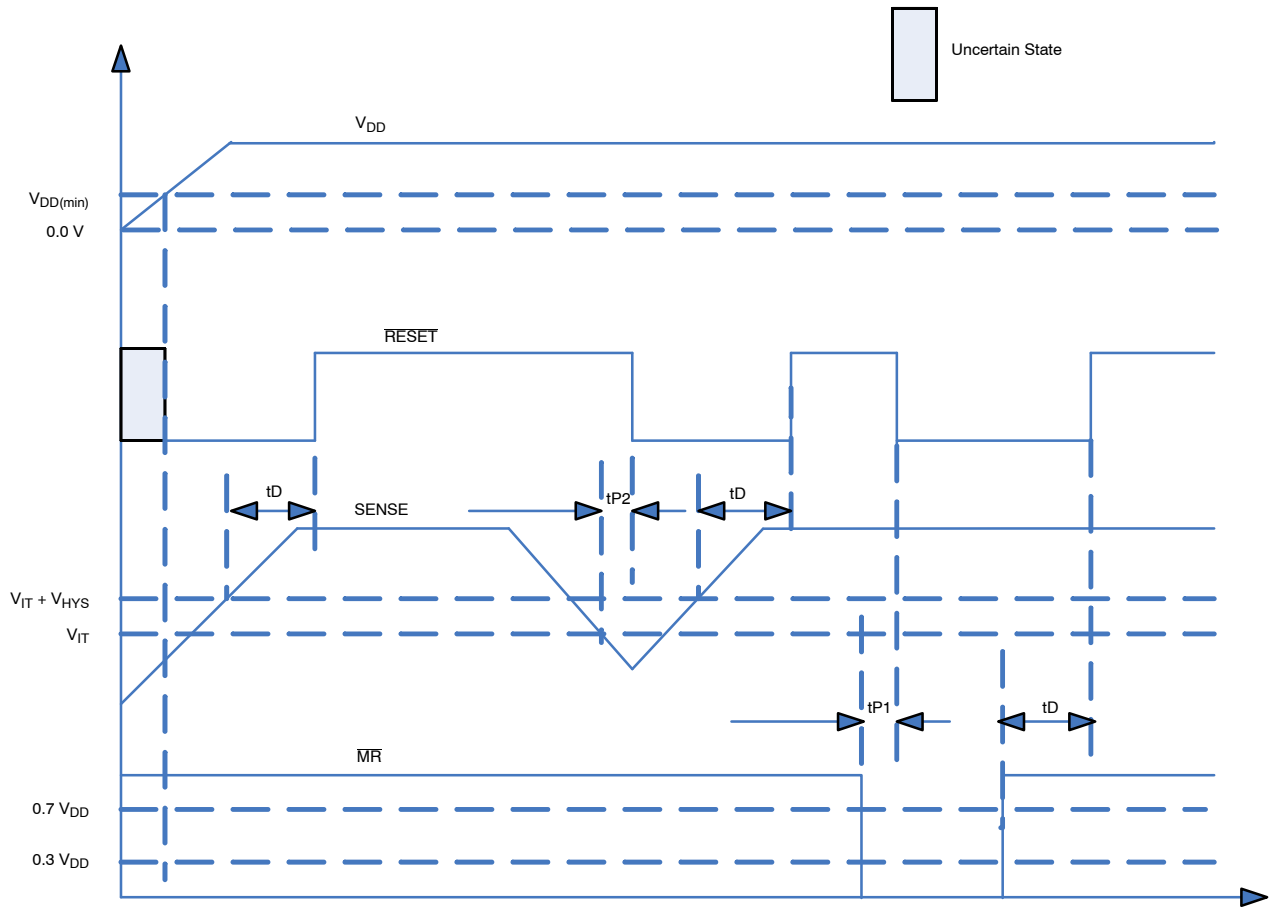

Figure 5. Timing Diagram Showing MR and SENSE Reset Timing

Table 2. TRUTH TABLE

MR	SENSE > V _{IT}	RESET
L	N	L
L	Y	L
H	N	L
H	Y	H

NCP308, NCV308

Table 3. MAXIMUM RATINGS

Rating	Symbol	Value	Unit
Input voltage range, V_{DD}	V_{DD}	-0.3 to + 6.0	V
CT voltage range V_{CT} , RESET, MR Current through CT pin	I_{CT}	-0.3 to $V_{DD} + 0.3 \leq 6.0$ 10	V mA
SENSE pin voltage		-0.3 to + 8.0	V
RESET pin current		5	mA
Thermal Resistance Junction-to-Air TSOP-6 WDFN6	$R_{\theta JA}$	305 220	°C/W
Human Body Model (HBM) ESD Rating (Note 1)	ESD HBM	2000	V
Machine Model (MM) ESD Rating (Note 1)	ESD MM	100	V
Charged Device Model (CDM) ESD Rating (Note 1)	ESD CDM	500	V
Latch up Current: (Note 2) All pins, except digital pins Digital pins (MR)	I_{LU}	± 100 ± 10	mA
Storage Temperature Range	T_{STG}	-65 to + 150	°C
Maximum Junction Temperature	T_J	-40 to +150	°C
Moisture Sensitivity (Note 3)	MSL	Level 1	

Stresses exceeding those listed in the Maximum Ratings table may damage the device. If any of these limits are exceeded, device functionality should not be assumed, damage may occur and reliability may be affected.

- This device series contains ESD protection and passes the following tests:
Human Body Model (HBM) +/-2.0 kV per JEDEC standard: JESD22-A114
Machine Model (MM) +/-100 V per JEDEC standard: JESD22-A115
Charged Device Model (CDM) 500 V per JEDEC standard: JESD22-C101.
- Latch up Current per JEDEC standard: JESD78 class II.
- Moisture Sensitivity Level (MSL): 1 per IPC/JEDEC standard: J-STD-020A.

NCP308, NCV308

Table 4. ELECTRICAL CHARACTERISTICS $1.6\text{ V} \leq V_{DD} \leq 5.5\text{ V}$, $R_{pullup} = 100\text{ k}\Omega$, $C_{LRESET} = 50\text{ pF}$, over operating temperature range ($T_J = -40^\circ\text{C}$ to $+125^\circ\text{C}$), unless otherwise specified. Typical values are at $T_J = +25^\circ\text{C}$.

Symbol	Parameter		Conditions	Min	Typ	Max	Unit
V_{DD}	Supply Voltage Range		$-40^\circ\text{C} < T_J < +125^\circ\text{C}$	1.6		5.5	V
$V_{DD(\text{min})}$	Minimum V_{DD} Guaranteed RESET Output Valid (Note 4)				0.5	0.8	V
I_{DD}	Supply Current (Current into VDD pin)		$V_{DD} = 3.3\text{V}$, RESET not asserted MR, RESET, CT open		1.6	5.0	μA
			$V_{DD} = 5.5\text{V}$, RESET not asserted MR, RESET, CT open		1.6	6.0	
V_{OL}	Low-level output voltage of RESET		$1.3\text{V} \leq V_{DD} < 1.6\text{V}$, $I_{OL} = 0.4\text{ mA}$			0.3	V
			$1.6\text{V} \leq V_{DD} \leq 5.5\text{V}$, $I_{OL} = 1.0\text{ mA}$			0.4	
$V_{IT\%}$	Negative going SENSE threshold voltage accuracy			-1.75	± 0.75	+1.75	%
			$T_J = +25^\circ\text{C}$	-0.31	-	0.31	
			$-20^\circ\text{C} < T_J < +85^\circ\text{C}$	-1.0	± 0.5	+1.0	
V_{HYS}	Hysteresis on V_{IT}	$1.6\text{V} \leq V_{DD} \leq 4.2\text{V}$			1.0	3.0	$\%V_{IT}$
		$4.2\text{V} \leq V_{DD} \leq 5.5\text{V}$			1.75	3.75	
R_{MR}	MR Internal pull-up resistance				90		$\text{k}\Omega$
I_{SENSE}	Input current at SENSE pin	NCP308XXADJ	$V_{SENSE} = V_{IT}$		10		nA
		Fixed versions	$V_{SENSE} = 5.5\text{ V}$		110		
I_{OH}	RESET leakage Current		$V_{RESET} = 5.5\text{ V}$, RESET not asserted			300	nA
C_{IN}	Input capacitance, any pin	CT pin	$V_{IN} = 0\text{ V to } V_{DD}$		5		pF
		Other pins	$V_{IN} = 0\text{ V to } 5.5\text{ V}$		5		
V_{IL}	MR logic low input			0		$0.3 V_{DD}$	V
V_{IH}	MR logic high input			$0.7 V_{DD}$		V_{DD}	V
t_w	Input pulse width to assert RESET	SENSE	$V_{IH} = 1.05 V_{IT}$, $V_{IL} = 0.95 V_{IT}$		20		μs
		MR	$V_{IH} = 0.7 V_{DD}$, $V_{IL} = 0.3 V_{DD}$		150		
t_D	Reset delay time	$C_T = \text{Open}$ $C_T = V_{DD}$ $C_T = 100\text{ pF}$ $C_T = 180\text{ nF}$	(Guaranteed by design and characterization)		20 300 1.25 1200		ms
t_{P1}	Propagation delay from MR	MR to RESET	$V_{IH} = 0.7 V_{DD}$, $V_{IL} = 0.3 V_{DD}$		150		ns
t_{P2}	Propagation delay from SENSE	SENSE to RESET	$V_{IH} = 1.05 V_{IT}$, $V_{IL} = 0.95 V_{IT}$		20		μs

4. The lowest supply voltage (V_{DD}) at which RESET becomes active.

5. NCP308XX: XX = MT (WDFN6 package) or SN (TSOP-6 package).

TYPICAL OPERATING CHARACTERISTICS

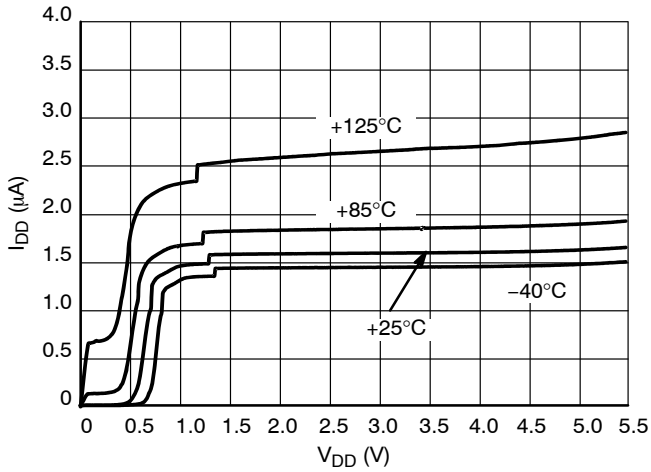

Figure 6. Supply Current vs. Input Voltage

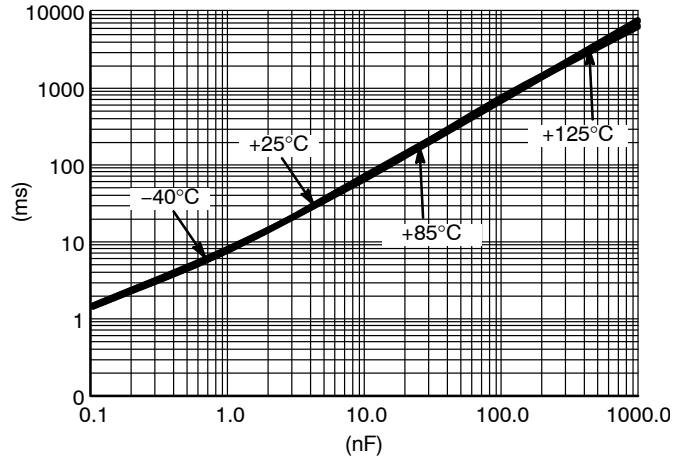

Figure 7. RESET Timeout Period vs. CT

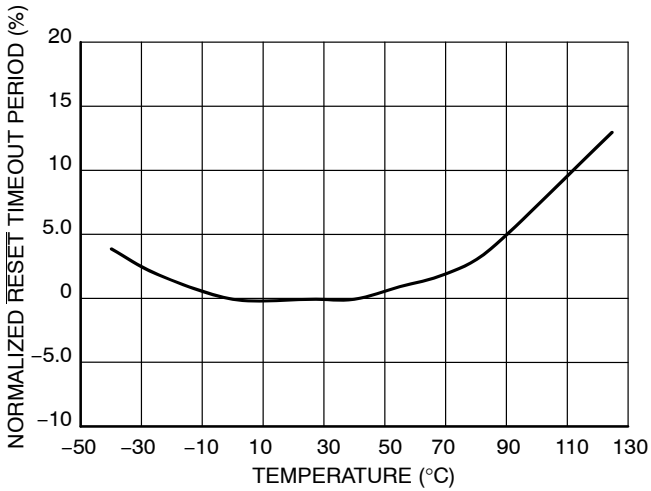

Figure 8. Normalized RESET Timeout Period vs. Temperature

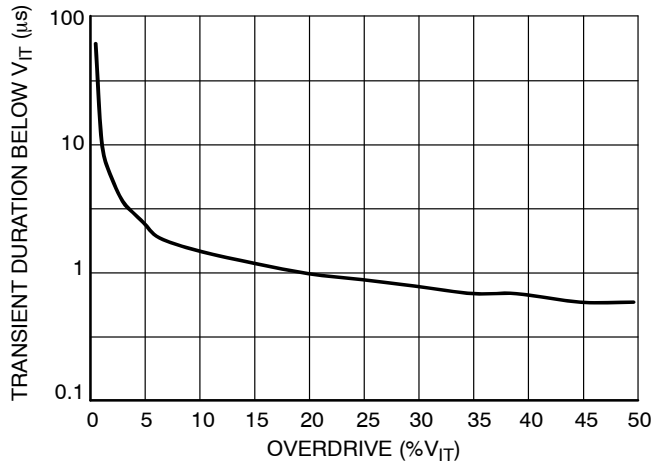

Figure 9. Maximum Transient Duration at Sense vs. Sense Threshold Overdrive Voltage

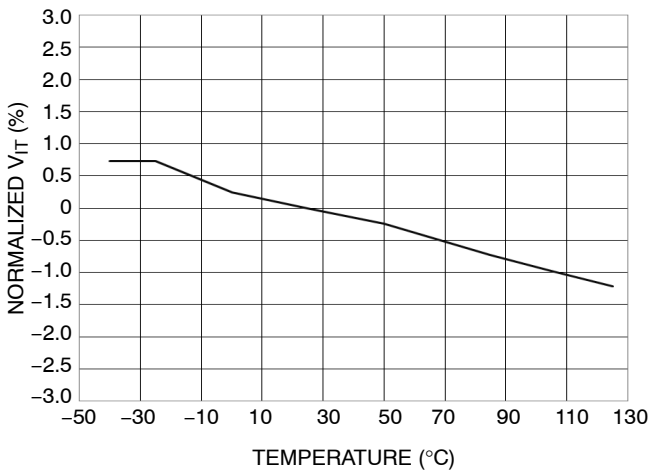

Figure 10. Normalized Sense Threshold Voltage (V_{IT}) vs. Temperature

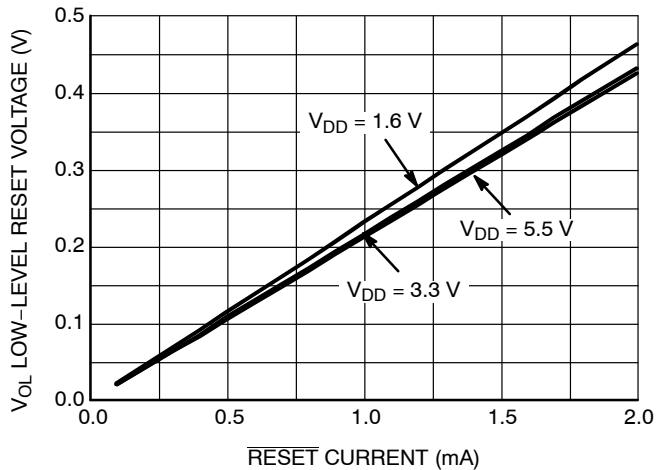

Figure 11. Low-Level RESET Voltage vs. RESET Current

DETAILED DESCRIPTION

The NCP308 microprocessor supervisory product family is designed to assert a $\overline{\text{RESET}}$ signal when either the SENSE pin voltage drops below V_{IT} or the Manual Reset input ($\overline{\text{MR}}$) is driven low. The $\overline{\text{RESET}}$ output remains asserted for a programmable delay time after both $\overline{\text{MR}}$ and SENSE voltages return above the respective thresholds. A broad range of voltage threshold and reset delay time options are available, allowing NCP308 series to be used in a wide range of applications.

Reset threshold voltages can be factory-set from 0.82 V to 3.3 V or from 4.4 V to 5.0 V, while the NCP308XXADJ can be used for any voltage above 0.405 V using an external resistor divider.

Flexible delay time can be easily got with CT pin according to Table 5:

Table 5. DELAY TIME SETTING TABLE

CT pin Configuration	Delay Time (tD)
CT = VDD	300 ms (fixed)
CT = Open	20 ms (fixed)
Connecting a capacitor between pin CT and GND (Capacitor CT value > 100 pF)	1.25 ms ~ 10 s, depends on capacitor value (Refer to the Setting Reset Delay Time Section)

Output

The $\overline{\text{RESET}}$ output is typically connected to the $\overline{\text{RESET}}$ control pin of a microprocessor. For Open-Drain output versions, a pull-up resistor must be used to hold this line high when $\overline{\text{RESET}}$ is not asserted. The $\overline{\text{RESET}}$ output is active once V_{DD} is over $V_{DD}(\text{min})$, this voltage is much lower than most microprocessors' functional voltage range. $\overline{\text{RESET}}$ remains high as long as SENSE is above its threshold (V_{IT}) and the Manual Reset input ($\overline{\text{MR}}$) is logic high. If either SENSE falls below V_{IT} or $\overline{\text{MR}}$ is driven low, $\overline{\text{RESET}}$ is asserted.

Once $\overline{\text{MR}}$ is again logic high and SENSE is above ($V_{IT} + V_{HYS}$), the $\overline{\text{RESET}}$ pin goes to a high impedance state after delay time (tD). The open-drain structure of $\overline{\text{RESET}}$ is capable to allow the reset signal for the microprocessor to have a voltage higher than V_{DD} (up to 5.5 V). The pull-up resistor should be no smaller than 10 k Ω as a result of the finite impedance of the $\overline{\text{RESET}}$ line.

SENSE Input

The SENSE input should be connected to the monitored voltage directly. If the voltage on this pin drops below V_{IT} , then $\overline{\text{RESET}}$ is asserted. The comparator has a built-in hysteresis to prevent erratic reset operation. It is good practice to put a 1 nF to 10 nF bypass capacitor on the SENSE input to reduce its sensitivity to transients and layout parasitic.

The NCP308XXADJ can be used to monitor any voltage rail down to 0.405 V by the circuit shown in Figure 12. The new V_{IT}' can be derived from resistor divider network of R1 and R2 by:

$$V_{IT}' = \left(\frac{R1}{R2} + 1 \right) \times V_{IT} \quad (\text{eq. 1})$$

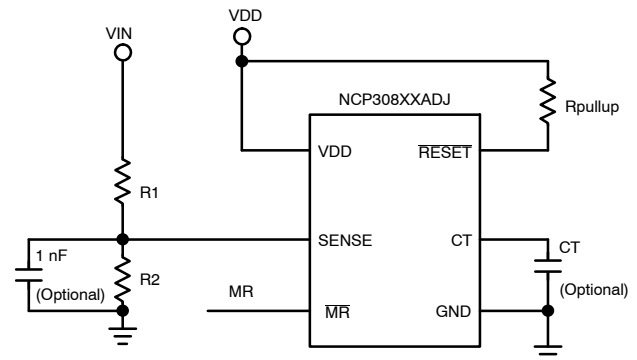

Figure 12. Using NCP308XXADJ to Monitor a User-Defined Threshold Voltage

Manual Reset Input ($\overline{\text{MR}}$)

The Manual Reset input ($\overline{\text{MR}}$) allows a processor or other logic circuits to initiate a reset. A logic low on $\overline{\text{MR}}$ causes $\overline{\text{RESET}}$ to assert. After $\overline{\text{MR}}$ returns to a logic high and SENSE is above its reset threshold, $\overline{\text{RESET}}$ is de-asserted after the delay time set by CT pin. $\overline{\text{MR}}$ is internally tied to V_{DD} by a 90 k Ω resistor so this pin can be left unconnected if $\overline{\text{MR}}$ will not be used.

Figure 13 shows how $\overline{\text{MR}}$ can be used to monitor multiple system voltages (e.g. I/O supply voltage of some DSP/processors should be setup before core voltage, and DSP/processor can only start after both I/O and core voltages setup).

NCP308, NCV308

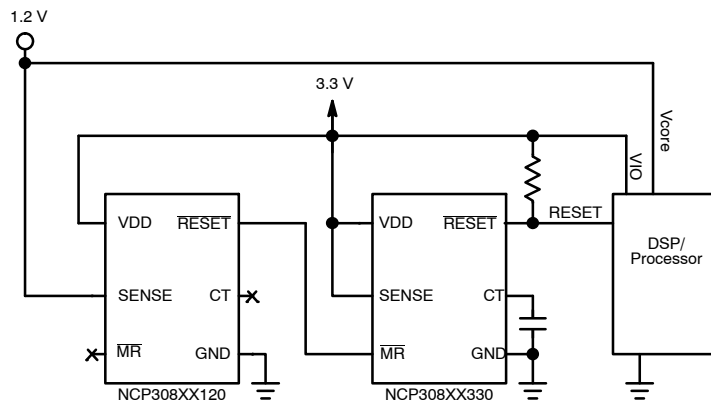

Figure 13. Using \overline{MR} to Monitor Multiple System Voltages

Setting Reset Delay Time

The NCP308 has three options for setting the reset delay time as shown in Table 5. Figure 14 shows the configuration for a fixed 300 ms typical delay time by tying CT to V_{DD}; a resistor from 40 k Ω to 200 k Ω must be used. Figure 15 shows a fixed 20 ms delay time by leaving the CT pin unconnected.

Figure 16 shows a user-defined program time between 1.25 ms and 10 s by connecting a capacitor between CT pin and ground.

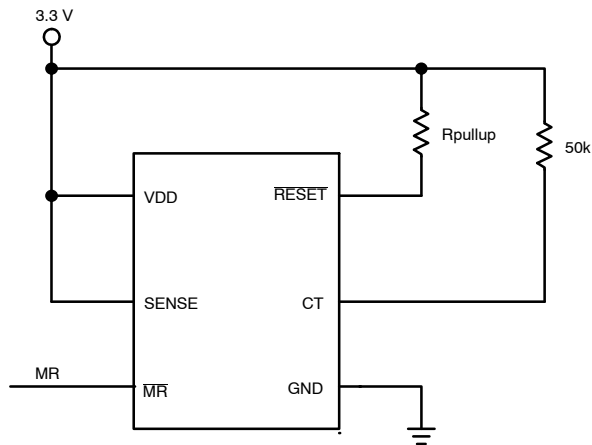

Figure 14. Delay Time Fixed to 300 ms when CT Connected to V_{DD} by Resistor

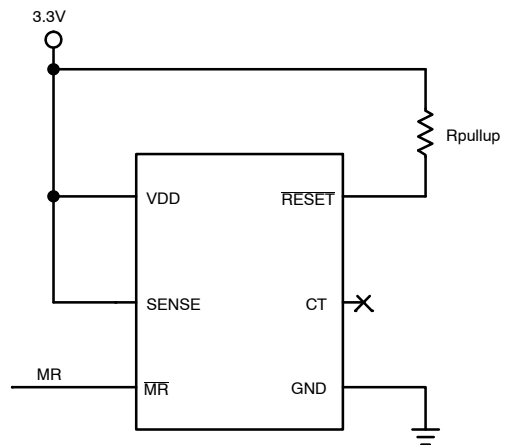

Figure 15. Delay Time Fixed to 20 ms when CT is Open

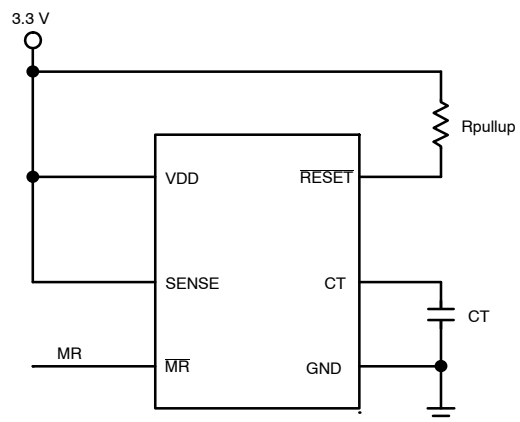

Figure 16. Delay Time Set by Capacitor

The capacitor CT should be ≥ 100 pF for NCP308 to recognize that the capacitor is present. The capacitor value for a given delay time can be calculated using the following equation:

NCP308, NCV308

$$CT(nF) = (tD(s) - 0.5 \times 10^{-3}(s)) \times 175 \quad (\text{eq. 2})$$

Parasitic capacitances of CT pin should be considered to avoid reset delay time deviation or error.

threshold overdrive, as shown in the Maximum Transient Duration at Sense vs. Sense Threshold Overdrive Voltage graph (Figure 9) in Typical Operating Characteristics section.

Immunity to Sense Pin Voltage Transients

NCP308 is relatively immune to short negative transients on SENSE pin. Sensitivity to transients is dependent on

ORDERING INFORMATION

Device	Status (Note 6)	Threshold Voltage (V _{IT})	Nominal Monitored Voltage	Marking	Package	Shipping [†]
NCP308SNADJT1G	Active	0.405 V	Adjustable Version	ADJ	TSOP-6 (Pb-Free)	3000 / Tape & Reel
NCV308SNADJT1G*	Active	0.405 V		VDJ		
NCP308SN090T1G	Active	0.84 V	0.9 V	090		
NCP308SN120T1G	Active	1.12 V	1.2 V	120		
NCP308SN125T1G	Active	1.16 V	1.25 V	125		
NCP308SN150T1G	Active	1.40 V	1.5 V	150		
NCP308SN180T1G	Active	1.67 V	1.8 V	180		
NCP308SN190T1G	Active	1.77 V	1.9 V	190		
NCP308SN250T1G	Active	2.33 V	2.5 V	250		
NCP308SN280T1G	Active	2.61 V	2.8 V	280		
NCP308SN300T1G	Active	2.79 V	3.0 V	300		
NCP308SN330T1G	Active	3.07 V	3.3 V	330		
NCV308SN330T1G*	Active	3.07 V	3.3 V	33A		
NCP308SN500T1G	Active	4.65 V	5.0 V	500		
NCP308MTADJTBG	Active	0.405 V	Adjustable Version	AA	WDFN6 (Pb-Free)	
NCP308MT090TBG	Active	0.84 V	0.9 V	AC		
NCP308MT120TBG	Active	1.12 V	1.2 V	AD		
NCP308MT125TBG	Active	1.16 V	1.25 V	AE		
NCP308MT150TBG	Active	1.40 V	1.5 V	AF		
NCP308MT180TBG	Active	1.67 V	1.8 V	AG		
NCP308MT190TBG	Active	1.77 V	1.9 V	AH		
NCP308MT250TBG	Active	2.33 V	2.5 V	AJ		
NCP308MT280TBG	Active	2.61 V	2.8 V	AK		
NCP308MT300TBG	Active	2.79 V	3.0 V	AL		
NCP308MT330TBG	Active	3.07 V	3.3 V	AM		
NCP308MT500TBG	Active	4.65 V	5.0 V	AN		

[†]For information on tape and reel specifications, including part orientation and tape sizes, please refer to our Tape and Reel Packaging Specifications Brochure, BRD8011/D.

*NCV Prefix for Automotive and Other Applications Requiring Unique Site and Control Change Requirements; AEC-Q100 Qualified and PPAP Capable.

6. The marketing status are defined as below:

Active: Products in production and recommended for new designs;

Under Request: Device has been announced but is not in production. Samples may or may not be available.

MECHANICAL CASE OUTLINE

PACKAGE DIMENSIONS

ON Semiconductor®



SCALE 2:1

TSOP-6 CASE 318G-02 ISSUE V

DATE 12 JUN 2012

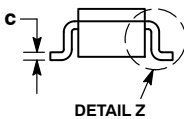
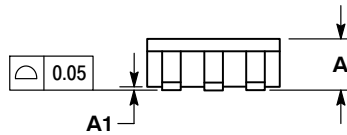
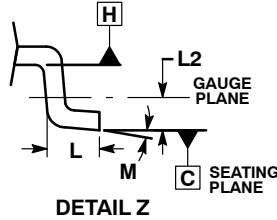
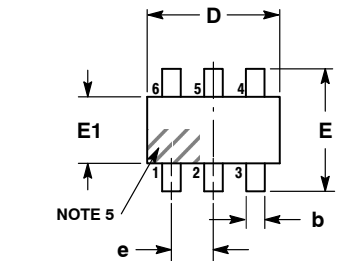

NOTES:

1. DIMENSIONING AND TOLERANCING PER ASME Y14.5M, 1994.
2. CONTROLLING DIMENSION: MILLIMETERS.
3. MAXIMUM LEAD THICKNESS INCLUDES LEAD FINISH. MINIMUM LEAD THICKNESS IS THE MINIMUM THICKNESS OF BASE MATERIAL.
4. DIMENSIONS D AND E1 DO NOT INCLUDE MOLD FLASH, PROTRUSIONS, OR GATE BURRS. MOLD FLASH, PROTRUSIONS, OR GATE BURRS SHALL NOT EXCEED 0.15 PER SIDE. DIMENSIONS D AND E1 ARE DETERMINED AT DATUM H.
5. PIN ONE INDICATOR MUST BE LOCATED IN THE INDICATED ZONE.

DIM	MILLIMETERS		
	MIN	NOM	MAX
A	0.90	1.00	1.10
A1	0.01	0.06	0.10
b	0.25	0.38	0.50
c	0.10	0.18	0.26
D	2.90	3.00	3.10
E	2.50	2.75	3.00
E1	1.30	1.50	1.70
e	0.85	0.95	1.05
L	0.20	0.40	0.60
L2	0.25 BSC		
M	0°	-	10°

- | | | | | | |
|--|--|---|---|---|--|
| <p>STYLE 1:
PIN 1. DRAIN
2. DRAIN
3. GATE
4. SOURCE
5. DRAIN
6. DRAIN</p> | <p>STYLE 2:
PIN 1. EMITTER 2
2. BASE 1
3. COLLECTOR 1
4. EMITTER 1
5. BASE 2
6. COLLECTOR 2</p> | <p>STYLE 3:
PIN 1. ENABLE
2. N/C
3. R BOOST
4. Vz
5. V in
6. V out</p> | <p>STYLE 4:
PIN 1. N/C
2. V in
3. NOT USED
4. GROUND
5. ENABLE
6. LOAD</p> | <p>STYLE 5:
PIN 1. EMITTER 2
2. BASE 2
3. COLLECTOR 1
4. EMITTER 1
5. BASE 1
6. COLLECTOR 2</p> | <p>STYLE 6:
PIN 1. COLLECTOR
2. COLLECTOR
3. BASE
4. EMITTER
5. COLLECTOR
6. COLLECTOR</p> |
| <p>STYLE 7:
PIN 1. COLLECTOR
2. COLLECTOR
3. BASE
4. N/C
5. COLLECTOR
6. EMITTER</p> | <p>STYLE 8:
PIN 1. Vbus
2. D(in)
3. D(in)+
4. D(out)+
5. D(out)
6. GND</p> | <p>STYLE 9:
PIN 1. LOW VOLTAGE GATE
2. DRAIN
3. SOURCE
4. DRAIN
5. DRAIN
6. HIGH VOLTAGE GATE</p> | <p>STYLE 10:
PIN 1. D(OUT)+
2. GND
3. D(OUT)-
4. D(IN)-
5. VBUS
6. D(IN)+</p> | <p>STYLE 11:
PIN 1. SOURCE 1
2. DRAIN 2
3. DRAIN 2
4. SOURCE 2
5. GATE 1
6. DRAIN 1/GATE 2</p> | <p>STYLE 12:
PIN 1. I/O
2. GROUND
3. I/O
4. I/O
5. VCC
6. I/O</p> |
| <p>STYLE 13:
PIN 1. GATE 1
2. SOURCE 2
3. GATE 2
4. DRAIN 2
5. SOURCE 1
6. DRAIN 1</p> | <p>STYLE 14:
PIN 1. ANODE
2. SOURCE
3. GATE
4. CATHODE/DRAIN
5. CATHODE/DRAIN
6. CATHODE/DRAIN</p> | <p>STYLE 15:
PIN 1. ANODE
2. SOURCE
3. GATE
4. DRAIN
5. N/C
6. CATHODE</p> | <p>STYLE 16:
PIN 1. ANODE/CATHODE
2. BASE
3. EMITTER
4. COLLECTOR
5. ANODE
6. CATHODE</p> | <p>STYLE 17:
PIN 1. EMITTER
2. BASE
3. ANODE/CATHODE
4. ANODE
5. CATHODE
6. COLLECTOR</p> | |

RECOMMENDED SOLDERING FOOTPRINT*

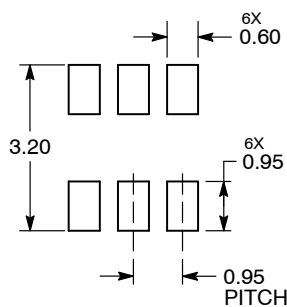

DIMENSIONS: MILLIMETERS

GENERIC MARKING DIAGRAM*



- | | |
|--|---|
| <p>XXX = Specific Device Code
A = Assembly Location
Y = Year
W = Work Week
■ = Pb-Free Package</p> | <p>XXX = Specific Device Code
M = Date Code
○ = Pb-Free Package</p> |
|--|---|

*For additional information on our Pb-Free strategy and soldering details, please download the ON Semiconductor Soldering and Mounting Techniques Reference Manual, SOLDERRM/D.

*This information is generic. Please refer to device data sheet for actual part marking. Pb-Free indicator, "G" or microdot "▪", may or may not be present.

DOCUMENT NUMBER:	98ASB14888C	Electronic versions are uncontrolled except when accessed directly from the Document Repository. Printed versions are uncontrolled except when stamped "CONTROLLED COPY" in red.
DESCRIPTION:	TSOP-6	PAGE 1 OF 1

ON Semiconductor and ON are trademarks of Semiconductor Components Industries, LLC dba ON Semiconductor or its subsidiaries in the United States and/or other countries. ON Semiconductor reserves the right to make changes without further notice to any products herein. ON Semiconductor makes no warranty, representation or guarantee regarding the suitability of its products for any particular purpose, nor does ON Semiconductor assume any liability arising out of the application or use of any product or circuit, and specifically disclaims any and all liability, including without limitation special, consequential or incidental damages. ON Semiconductor does not convey any license under its patent rights nor the rights of others.



SCALE 4:1

WDFN6 2x2, 0.65P
CASE 511BR
ISSUE B

DATE 19 JAN 2016

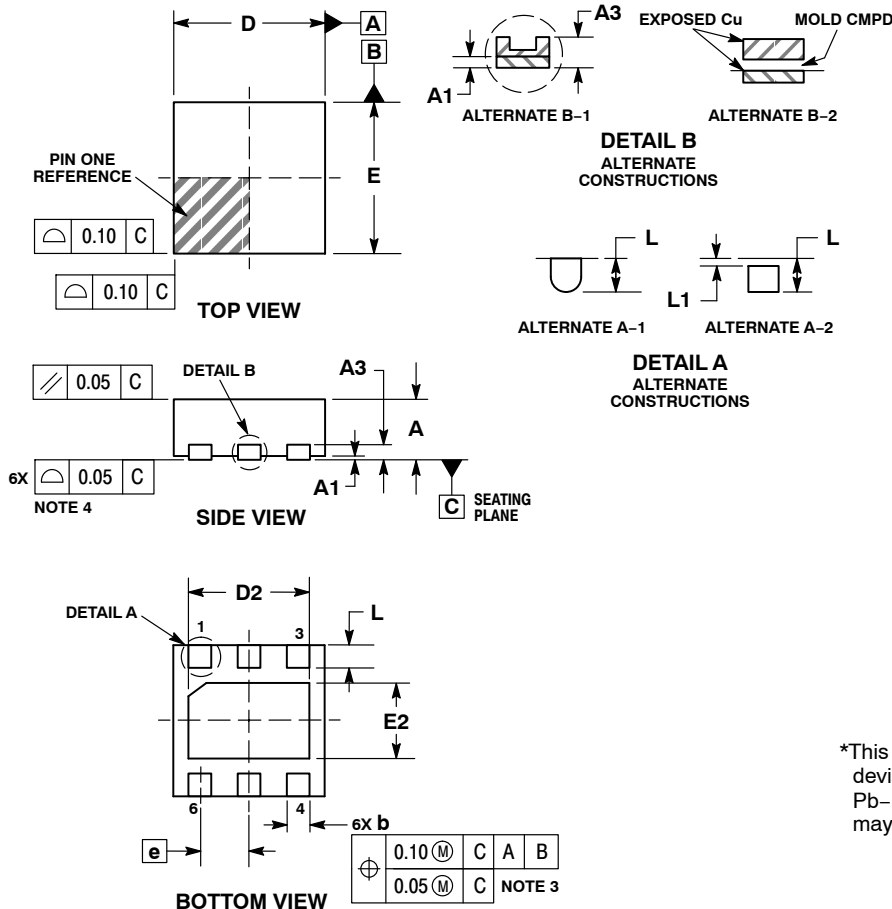

- NOTES:
1. DIMENSIONING AND TOLERANCING PER ASME Y14.5M, 1994.
 2. CONTROLLING DIMENSION: MILLIMETERS.
 3. DIMENSION b APPLIES TO PLATED TERMINAL AND IS MEASURED BETWEEN 0.15 AND 0.25 mm FROM THE TERMINAL TIP.
 4. COPLANARITY APPLIES TO THE EXPOSED PAD AS WELL AS THE TERMINALS.
 5. FOR DEVICES CONTAINING WETTABLE FLANK OPTION, DETAIL A ALTERNATE CONSTRUCTION A-2 AND DETAIL B ALTERNATE CONSTRUCTION B-2 ARE NOT APPLICABLE.

DIM	MILLIMETERS	
	MIN	MAX
A	0.70	0.80
A1	0.00	0.05
A3	0.20	REF
b	0.25	0.35
D	2.00 BSC	
D2	1.50	1.70
E	2.00 BSC	
E2	0.90	1.10
e	0.65 BSC	
L	0.20	0.40
L1	---	0.15

GENERIC MARKING DIAGRAM*



XX = Specific Device Code
 M = Date Code

*This information is generic. Please refer to device data sheet for actual part marking. Pb-Free indicator, "G" or microdot "▪", may or may not be present.

RECOMMENDED MOUNTING FOOTPRINT

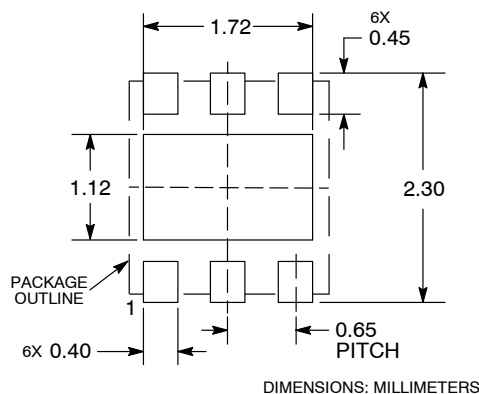

DOCUMENT NUMBER:	98AON55829E	Electronic versions are uncontrolled except when accessed directly from the Document Repository. Printed versions are uncontrolled except when stamped "CONTROLLED COPY" in red.
DESCRIPTION:	WDFN6 2X2, 0.65P	PAGE 1 OF 1

ON Semiconductor and are trademarks of Semiconductor Components Industries, LLC dba ON Semiconductor or its subsidiaries in the United States and/or other countries. ON Semiconductor reserves the right to make changes without further notice to any products herein. ON Semiconductor makes no warranty, representation or guarantee regarding the suitability of its products for any particular purpose, nor does ON Semiconductor assume any liability arising out of the application or use of any product or circuit, and specifically disclaims any and all liability, including without limitation special, consequential or incidental damages. ON Semiconductor does not convey any license under its patent rights nor the rights of others.

onsemi, **Onsemi**, and other names, marks, and brands are registered and/or common law trademarks of Semiconductor Components Industries, LLC dba "**onsemi**" or its affiliates and/or subsidiaries in the United States and/or other countries. **onsemi** owns the rights to a number of patents, trademarks, copyrights, trade secrets, and other intellectual property. A listing of **onsemi**'s product/patent coverage may be accessed at www.onsemi.com/site/pdf/Patent-Marking.pdf. **onsemi** reserves the right to make changes at any time to any products or information herein, without notice. The information herein is provided "as-is" and **onsemi** makes no warranty, representation or guarantee regarding the accuracy of the information, product features, availability, functionality, or suitability of its products for any particular purpose, nor does **onsemi** assume any liability arising out of the application or use of any product or circuit, and specifically disclaims any and all liability, including without limitation special, consequential or incidental damages. Buyer is responsible for its products and applications using **onsemi** products, including compliance with all laws, regulations and safety requirements or standards, regardless of any support or applications information provided by **onsemi**. "Typical" parameters which may be provided in **onsemi** data sheets and/or specifications can and do vary in different applications and actual performance may vary over time. All operating parameters, including "Typicals" must be validated for each customer application by customer's technical experts. **onsemi** does not convey any license under any of its intellectual property rights nor the rights of others. **onsemi** products are not designed, intended, or authorized for use as a critical component in life support systems or any FDA Class 3 medical devices or medical devices with a same or similar classification in a foreign jurisdiction or any devices intended for implantation in the human body. Should Buyer purchase or use **onsemi** products for any such unintended or unauthorized application, Buyer shall indemnify and hold **onsemi** and its officers, employees, subsidiaries, affiliates, and distributors harmless against all claims, costs, damages, and expenses, and reasonable attorney fees arising out of, directly or indirectly, any claim of personal injury or death associated with such unintended or unauthorized use, even if such claim alleges that **onsemi** was negligent regarding the design or manufacture of the part. **onsemi** is an Equal Opportunity/Affirmative Action Employer. This literature is subject to all applicable copyright laws and is not for resale in any manner.

PUBLICATION ORDERING INFORMATION

LITERATURE FULFILLMENT:

Email Requests to: orderlit@onsemi.com

onsemi Website: www.onsemi.com

TECHNICAL SUPPORT

North American Technical Support:

Voice Mail: 1 800-282-9855 Toll Free USA/Canada

Phone: 011 421 33 790 2910

Europe, Middle East and Africa Technical Support:

Phone: 00421 33 790 2910

For additional information, please contact your local Sales Representative