

# NC7SZ74

## TinyLogic UHS D-Type, Flip-Flop with Preset and Clear

### Description

The NC7SZ74 is a single, D-type, CMOS flip-flop with preset and clear from ON Semiconductor ultra high-speed series of TinyLogic. The device is fabricated with advanced CMOS technology to achieve ultra high speed with high output drive, while maintaining low static power dissipation over a very broad  $V_{CC}$  operating range of 1.65 V to 5.5 V  $V_{CC}$ . The inputs and outputs are high impedance when  $V_{CC}$  is 0 V. Inputs tolerate voltages up to 5.5 V, independent of  $V_{CC}$  operating voltage.

The signal level applied to the D input is transferred to the Q output during the positive-going transition of the CLK pulse.

### Features

- Ultra-High Speed:  $t_{PD}$  2.6 ns (Typical) into 50 pF at 5 V  $V_{CC}$
- High Output Drive:  $\pm 24$  mA at 3 V  $V_{CC}$
- Broad  $V_{CC}$  Operating Range: 1.65 V to 5.5 V
- Power Down High-Impedance Inputs/Outputs
- Over-Voltage Tolerance Inputs Facilitate 5 V to 3 V Translation
- Proprietary Noise/EMI Reduction Circuitry

### Pin Configurations

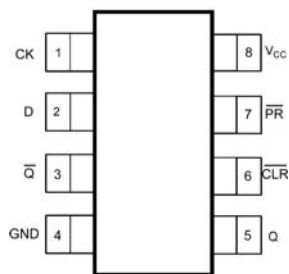

Figure 2. USB (Top View)

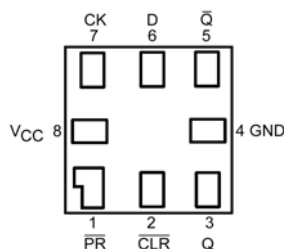

Figure 3. MicorPak™ (Top Through View)

### PIN DEFINITIONS

Pin # US8	Pin # MicroPak	Name	Description
1	7	CK	Clock Pulse Input
2	6	D	Data Input
3	5	$\bar{Q}$	Flip-Flop Output
4	4	GND	Ground
5	3	Q	Flip-Flop Output
6	2	$\bar{CLR}$	Direct Clear Input
7	1	$\bar{PR}$	Direct Preset Input
8	8	Vcc	Supply Voltage



ON Semiconductor®

[www.onsemi.com](http://www.onsemi.com)

US8  
CASE 846AN

UQFN8 1.6x1.6, 0.5P  
CASE 523AY

### CONNECTION DIAGRAMS

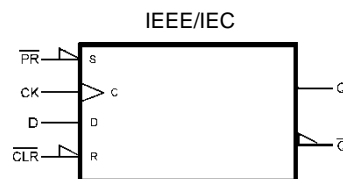

Figure 1. Logic Symbol

### ORDERING INFORMATION

See detailed ordering and shipping information on page 2 of this data sheet.

# NC7SZ74

## ORDERING INFORMATION

Part Number	Top Mark	Package	Packing Method†
NC7SZ74K8X	SZ74	8-Lead US8, JEDEC MO-187, Variation CA 3.1mm Wide	3000 Units on Tape & Reel
NC7SZ74L8X	N9	8-Lead MicroPak, 1.6 mm Wide	5000 Units on Tape & Reel

†For information on tape and reel specifications, including part orientation and tape sizes, please refer to our Tape and Reel Packaging Specifications Brochure, BRD8011/D

## FUNCTION TABLE

Inputs				Output		Function
/CLR	/PR	D	CK	Q	/Q	
L	H	X	X	L	H	Clear
H	L	X	X	H	L	Preset
L	L	X	X	H	H	
H	H	L	↑	L	H	
H	H	H	↑	H	L	
H	H	X	↓	Q <sub>n</sub>	/Q <sub>n</sub>	No Change

H = HIGH Logic Level

Q<sub>n</sub> = No change in data

X = Immaterial

↓ = Falling Edge

L = LOW Logic Level

Z = High Impedance

↑ = Rising Edge

## ABSOLUTE MAXIMUM RATINGS

Symbol	Parameter	Min.	Max.	Unit
V <sub>CC</sub>	Supply Voltage	-0.5	6.5	V
V <sub>IN</sub>	DC Input Voltage	-0.5	6.5	V
V <sub>OUT</sub>	DC Output Voltage	-0.5	6.5	V
I <sub>IK</sub>	DC Input Diode Current		-50	mA
I <sub>OK</sub>	DC Output Diode Current		-50	mA
I <sub>OUT</sub>	DC Output Source/Sink Current		±50	mA
I <sub>CC</sub> or I <sub>GND</sub>	DC V <sub>CC</sub> or Ground Current		±50	mA
T <sub>STG</sub>	Storage Temperature Range	-65	+150	°C
T <sub>J</sub>	Junction Temperature Under Bias		+150	°C
T <sub>L</sub>	Junction Lead Temperature (Soldering, 10 Seconds)		+260	°C
P <sub>D</sub>	Power Dissipation at +85°C		250	mW
ESD	Human Body Model, JEDEC:JESD22-A114		5000	V
	Charge Device Model: JEDEC:JESD22-C101		2000	

Stresses exceeding those listed in the Maximum Ratings table may damage the device. If any of these limits are exceeded, device functionality should not be assumed, damage may occur and reliability may be affected.

## RECOMMENDED OPERATING CONDITIONS

Symbol	Parameter	Conditions	Min.	Max.	Unit
V <sub>CC</sub>	Supply Voltage Operating		1.65	5.50	V
	Supply Voltage Data Retention		1.50	5.50	
V <sub>IN</sub>	Input Voltage		0	5.5	V
V <sub>OUT</sub>	Output Voltage	Active State	0	V <sub>CC</sub>	V
		3-State	0	5.5	

# NC7SZ74

## RECOMMENDED OPERATING CONDITIONS (continued)

Symbol	Parameter	Conditions	Min.	Max.	Unit
$t_r, t_f$	Input Rise and Fall Times	$V_{CC} = 1.8\text{ V}, 2.5\text{ V} \pm 0.2\text{ V}$	0	20	ns/V
		$V_{CC} = 3.3\text{ V} \pm 0.3\text{ V}$	0	10	
		$V_{CC} = 5.0\text{ V} \pm 0.5\text{ V}$	0	5	
$T_A$	Operating Temperature		-40	+85	°C
$\theta_{JA}$	Thermal Resistance	US8		250	°C/W
		MicroPak™ -8		280	

Functional operation above the stresses listed in the Recommended Operating Ranges is not implied. Extended exposure to stresses beyond the Recommended Operating Ranges limits may affect device reliability.

NOTE: Unused inputs must be held HIGH or LOW. They may not float.

## DC ELECTRICAL CHARACTERISTICS

Symbol	Parameter	Vcc	Conditions	$T_A = +25^\circ\text{C}$			$T_A = -40\text{ to }+85^\circ\text{C}$		Units
				Min.	Typ.	Max.	Min.	Max.	
$V_{IH}$	HIGH Level Control Input Voltage	1.65 to 1.95		$0.65 V_{CC}$			$0.65 V_{CC}$		V
		2.30 to 5.50		$0.70 V_{CC}$			$0.70 V_{CC}$		
$V_{IL}$	LOW Level Control Input Voltage	1.65 to 1.95				$0.35 V_{CC}$		$0.35 V_{CC}$	V
		2.30 to 5.50				$0.30 V_{CC}$		$0.30 V_{CC}$	
$V_{OH}$	HIGH Level Output Voltage	1.65	$V_{IN} = V_{IH}, I_{OH} = -100\ \mu\text{A}$	1.55	1.65		1.55		V
		2.30		2.20	2.30		2.20		
		3.00		2.90	3.00		2.90		
		4.50		4.40	4.50		4.40		
		1.65	$I_{OH} = -4\text{ mA}$	1.29	1.52		1.29		
		2.30		1.90	2.15		1.90		
		3.00		2.40	2.80		2.40		
		3.00		2.30	2.68		2.30		
		4.50		3.80	4.20		3.80		
$V_{OL}$	LOW Level Control Output Voltage	1.65	$V_{IN} = V_{IH}, I_{OL} = 100\ \mu\text{A}$			0.10		0.10	V
		2.30				0.10		0.10	
		3.00				0.10		0.10	
		4.50				0.10		0.10	
		1.65	$I_{OL} = 4\text{ mA}$		0.10	0.24		0.24	
		2.30			0.10	0.30		0.30	
		3.00			0.15	0.40		0.40	
		3.00			0.22	0.55		0.55	
		4.50			0.22	0.55		0.55	
$I_{IN}$	Input Leakage Current	1.65 to 5.5	$0 \leq V_{IN} \leq 5.5\text{ V}$			$\pm 0.1$		$\pm 1.0$	$\mu\text{A}$
$I_{OFF}$	Power Off Leakage Current	0	$V_{IN}$ or $V_{OUT} = 5.5\text{ V}$			1		10	$\mu\text{A}$
$I_{CC}$	Quiescent Supply Current	1.65 to 5.50	$V_{IN} = 5.5\text{ V}, \text{GND}$			1		10	$\mu\text{A}$

# NC7SZ74

## AC ELECTRICAL CHARACTERISTICS

Symbol	Parameter	V <sub>CC</sub>	Conditions	T <sub>A</sub> = +25°C			T <sub>A</sub> = -40 to +85°C		Units	Figure
				Min.	Typ.	Max.	Min.	Max.		
f <sub>MAX</sub>	Maximum Clock Frequency	1.80 ± 0.15	C <sub>L</sub> = 15 pF R <sub>D</sub> = 1 MΩ S <sub>1</sub> = Open	75			75		ns	Figure 4 Figure 8
		2.50 ± 0.20		150			150			
		3.30 ± 0.30		200			200			
		5.00 ± 0.50		250			250			
		3.30 ± 0.50	C <sub>L</sub> = 50 pF R <sub>D</sub> = 500 Ω, S <sub>1</sub> = Open	175			175			
		5.00 ± 0.50		200			200			
t <sub>PLH</sub> , t <sub>PHL</sub>	Propagation Delay CK to Q, /Q	1.80 ± 0.15	C <sub>L</sub> = 15 pF, R <sub>D</sub> = 1 MΩ S <sub>1</sub> = Open		6.5	12.5		13.0	ns	Figure 4 Figure 6
		2.50 ± 0.20			3.8	7.5		8.0		
		3.30 ± 0.30			2.8	6.5		7.0		
		5.00 ± 0.50			2.2	4.5		5.0		
		3.30 ± 0.30	C <sub>L</sub> = 50 pF R <sub>D</sub> = 500 Ω, S <sub>1</sub> = Open		3.4	7.0		7.5		
		5.00 ± 0.50			2.6	5.0		5.5		
t <sub>PLH</sub> , t <sub>PHL</sub>	Propagation Delay /CLR, /PR to Q, /Q	1.80 ± 0.15	C <sub>L</sub> = 15 pF, R <sub>L</sub> = 1 MΩ S <sub>1</sub> = Open		6.5	14.0		14.5	ns	Figure 4 Figure 6
		2.50 ± 0.20			3.8	9.0		9.5		
		3.30 ± 0.30			2.8	6.5		7.0		
		5.00 ± 0.50			2.2	5.0		5.5		
		3.30 ± 0.30	C <sub>L</sub> = 50 pF, R <sub>D</sub> = 500 Ω, S <sub>1</sub> = Open		3.4	7.0		7.5		
		5.00 ± 0.50			2.6	5.0		5.5		
t <sub>S</sub>	Setup Time CK to D	1.80 ± 0.15	C <sub>L</sub> = 15 pF, R <sub>L</sub> = 1 MΩ S <sub>1</sub> = Open	6.5			6.5		ns	Figure 4 Figure 7
		2.50 ± 0.20		3.5			3.5			
		3.30 ± 0.30		2.0			2.0			
		5.00 ± 0.50		1.5			1.5			
		3.30 ± 0.30	C <sub>L</sub> = 50 pF, R <sub>D</sub> = 500 Ω, S <sub>1</sub> = Open	2.0			2.0			
		5.00 ± 0.50		1.5			1.5			
t <sub>H</sub>	Hold Time, CK to D	1.80 ± 0.15	C <sub>L</sub> = 15 pF, R <sub>L</sub> = 1 MΩ S <sub>1</sub> = Open	0.5			0.5		ns	Figure 4 Figure 7
		2.50 ± 0.20		0.5			0.5			
		3.30 ± 0.30		0.5			0.5			
		5.00 ± 0.50		0.5			0.5			
		3.30 ± 0.30	C <sub>L</sub> = 50 pF, R <sub>D</sub> = 500 Ω, S <sub>1</sub> = Open	0.5			0.5			
		5.00 ± 0.50		0.5			0.5			
t <sub>W</sub>	Pulse Width, CK, /PR, /CLR	1.80 ± 0.15	C <sub>L</sub> = 15 pF, R <sub>L</sub> = 1 MΩ S <sub>1</sub> = Open	6.0			6.0		ns	Figure 4 Figure 8
		2.50 ± 0.20		4.0			4.0			
		3.30 ± 0.30		3.0			3.0			
		5.00 ± 0.50		2.0			2.0			
		3.30 ± 0.30	C <sub>L</sub> = 50 pF, R <sub>D</sub> = 500 Ω, S <sub>1</sub> = Open	3.0			3.0			
		5.00 ± 0.50		2.0			2.0			

# NC7SZ74

## AC ELECTRICAL CHARACTERISTICS (continued)

Symbol	Parameter	V <sub>CC</sub>	Conditions	T <sub>A</sub> = +25°C			T <sub>A</sub> = -40 to +85°C		Units	Figure	
				Min.	Typ.	Max.	Min.	Max.			
t <sub>REC</sub>	Recover Time /CLR, /PR to CK	1.80 ± 0.15	C <sub>L</sub> = 15 pF, R <sub>L</sub> = 1 MΩ S <sub>1</sub> = Open	8.0			8.0		ns	Figure 7	
				4.5			4.5				
		3.30 ± 0.30				3.0					
		5.00 ± 0.50				3.0					
		3.30 ± 0.30		C <sub>L</sub> = 50 pF, R <sub>D</sub> = 500 Ω, S <sub>1</sub> = Open	3.0			3.0			
		5.00 ± 0.50			3.0			3.0			
C <sub>IN</sub>	Input Capacitance	0			3			pF			
C <sub>OUT</sub>	Output Capacitance	0			4			pF			
C <sub>PD</sub>	Power Dissipation Capacitance (Note 1)	3.30			10			pF			
		5.00			12						

1. C<sub>PD</sub> is defined as the value of the internal equivalent capacitance which is derived from dynamic operating current consumption (I<sub>CCD</sub>) at no output loading and operating at 50% duty cycle. C<sub>PD</sub> is related to I<sub>CCD</sub> dynamic operating current by the expression: I<sub>CCD</sub> = (C<sub>PD</sub>)(V<sub>CC</sub>)(f<sub>IN</sub>) + (I<sub>CC</sub>static).

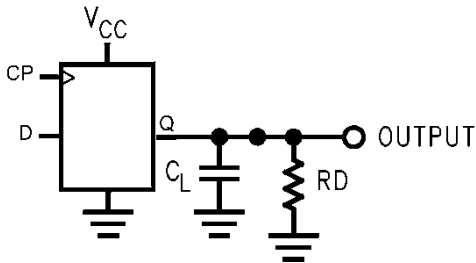

2. C<sub>L</sub> includes load and stray capacitance. Input PRR = 1.0 MHz t<sub>w</sub> = 500 ns.

**Figure 4. AC Test Circuit**

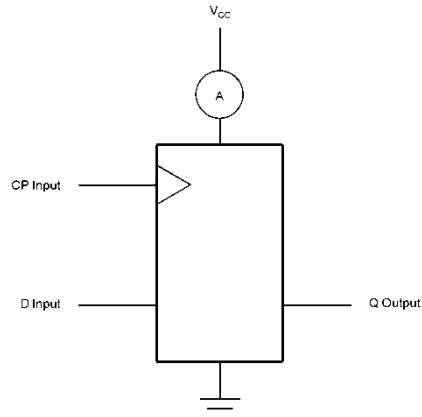

3. CP input = AC Waveforms t<sub>r</sub> = t<sub>f</sub> = 2.5 ns.  
4. CP input PRR = 10 MHz; Duty Cycle = 50%.  
5. D input PRR = 5 MHz; Duty Cycle = 50%.

**Figure 5. AC Test Circuit**

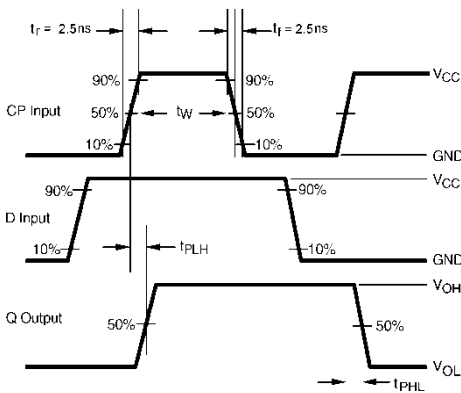

**Figure 6. AC Waveforms**

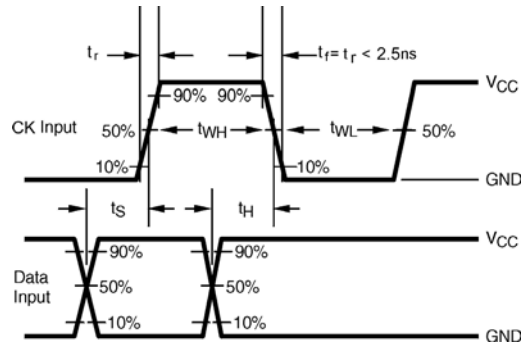

**Figure 7. AC Waveforms**

# NC7SZ74

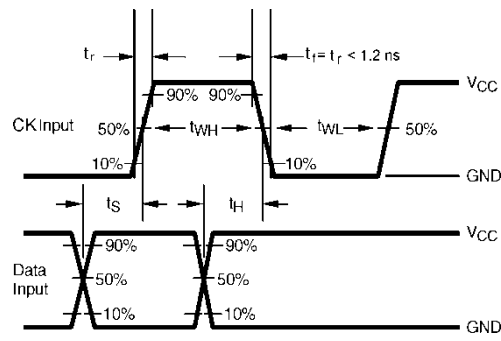
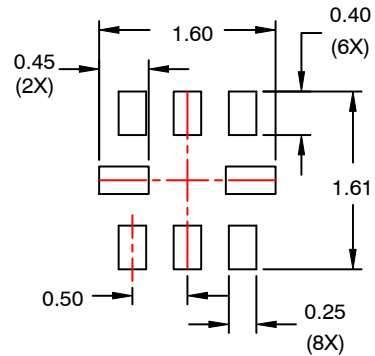
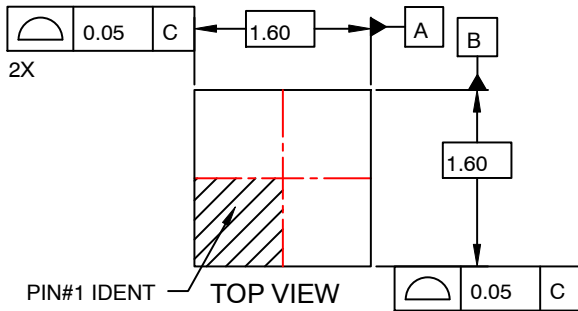

Figure 8. AC Waveforms



**UQFN8 1.6X1.6, 0.5P**  
CASE 523AY  
ISSUE O

DATE 31 AUG 2016



**RECOMMENDED  
LAND PATTERN**

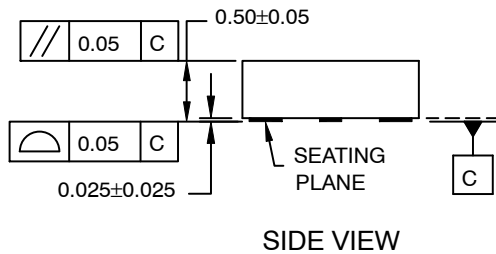

**SIDE VIEW**

**NOTES:**

- A. PACKAGE CONFORMS TO JEDEC MO-255 VARIATION UAAD.
- B. DIMENSIONS ARE IN MILLIMETERS.
- C. DIMENSIONS AND TOLERANCES PER ASME Y14.5M, 2009.
- D. LAND PATTERN RECOMMENDATION IS EXISTING INDUSTRY LAND PATTERN.

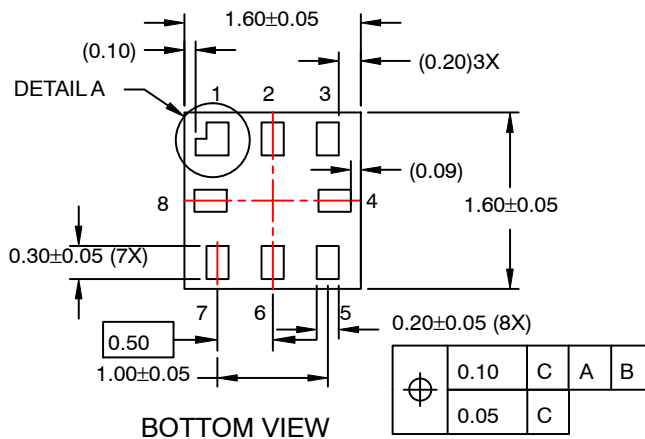

**BOTTOM VIEW**

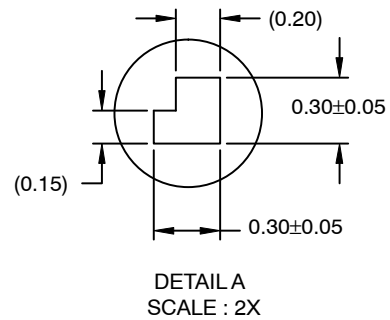

**DETAIL A  
SCALE : 2X**

<b>DOCUMENT NUMBER:</b>	<b>98AON13591G</b>	Electronic versions are uncontrolled except when accessed directly from the Document Repository. Printed versions are uncontrolled except when stamped "CONTROLLED COPY" in red.
<b>DESCRIPTION:</b>	<b>UQFN8 1.6X1.6, 0.5P</b>	<b>PAGE 1 OF 1</b>

ON Semiconductor and are trademarks of Semiconductor Components Industries, LLC dba ON Semiconductor or its subsidiaries in the United States and/or other countries. ON Semiconductor reserves the right to make changes without further notice to any products herein. ON Semiconductor makes no warranty, representation or guarantee regarding the suitability of its products for any particular purpose, nor does ON Semiconductor assume any liability arising out of the application or use of any product or circuit, and specifically disclaims any and all liability, including without limitation special, consequential or incidental damages. ON Semiconductor does not convey any license under its patent rights nor the rights of others.



US8  
CASE 846AN  
ISSUE O

DATE 31 DEC 2016

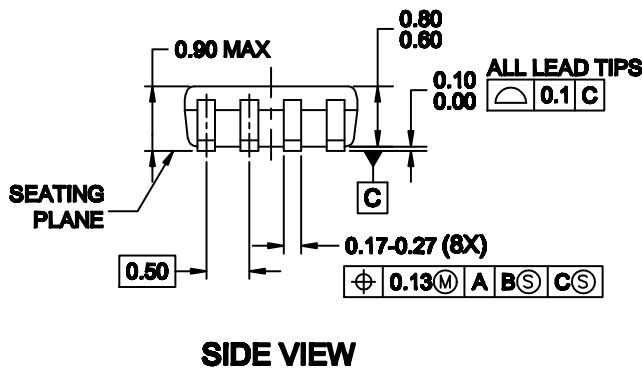
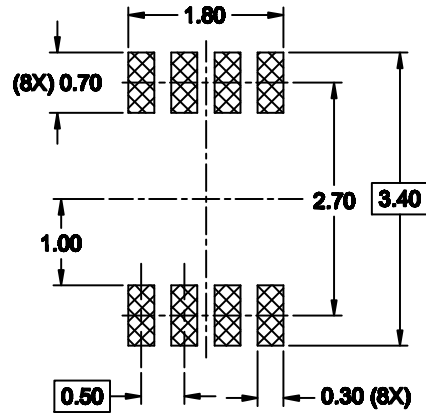
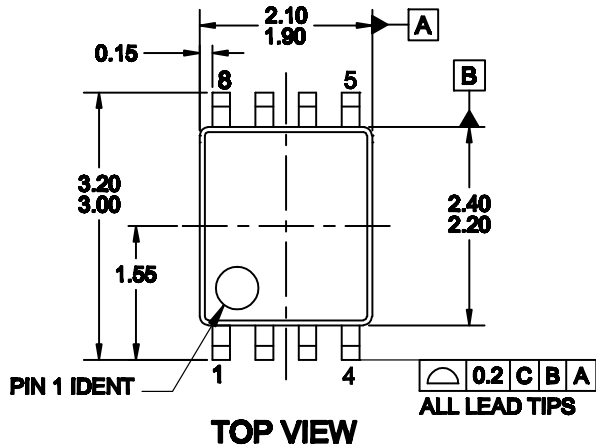

**NOTES:**

- A. CONFORMS TO JEDEC REGISTRATION MO-187
- B. DIMENSIONS ARE IN MILLIMETERS.
- C. DIMENSIONS ARE EXCLUSIVE OF BURRS, MOLD FLASH, AND TIE BAR EXTRUSIONS.
- D. DIMENSIONS AND TOLERANCES PER ANSI Y14.5M, 1994.

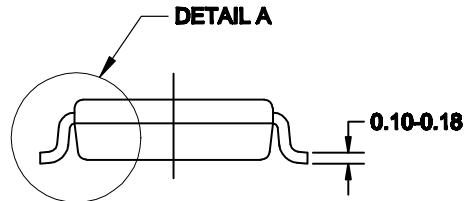
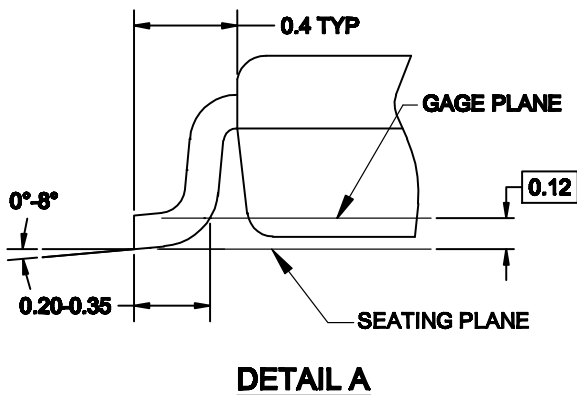

DOCUMENT NUMBER:	98AON13778G	Electronic versions are uncontrolled except when accessed directly from the Document Repository. Printed versions are uncontrolled except when stamped "CONTROLLED COPY" in red.
STATUS:	ON SEMICONDUCTOR STANDARD	
NEW STANDARD:		
DESCRIPTION:	US8	PAGE 1 OF 2



ON Semiconductor and  are trademarks of Semiconductor Components Industries, LLC dba ON Semiconductor or its subsidiaries in the United States and/or other countries. ON Semiconductor owns the rights to a number of patents, trademarks, copyrights, trade secrets, and other intellectual property. A listing of ON Semiconductor's product/patent coverage may be accessed at [www.onsemi.com/site/pdf/Patent-Marking.pdf](http://www.onsemi.com/site/pdf/Patent-Marking.pdf). ON Semiconductor reserves the right to make changes without further notice to any products herein. ON Semiconductor makes no warranty, representation or guarantee regarding the suitability of its products for any particular purpose, nor does ON Semiconductor assume any liability arising out of the application or use of any product or circuit, and specifically disclaims any and all liability, including without limitation special, consequential or incidental damages. Buyer is responsible for its products and applications using ON Semiconductor products, including compliance with all laws, regulations and safety requirements or standards, regardless of any support or applications information provided by ON Semiconductor. "Typical" parameters which may be provided in ON Semiconductor data sheets and/or specifications can and do vary in different applications and actual performance may vary over time. All operating parameters, including "Typicals" must be validated for each customer application by customer's technical experts. ON Semiconductor does not convey any license under its patent rights nor the rights of others. ON Semiconductor products are not designed, intended, or authorized for use as a critical component in life support systems or any FDA Class 3 medical devices or medical devices with a same or similar classification in a foreign jurisdiction or any devices intended for implantation in the human body. Should Buyer purchase or use ON Semiconductor products for any such unintended or unauthorized application, Buyer shall indemnify and hold ON Semiconductor and its officers, employees, subsidiaries, affiliates, and distributors harmless against all claims, costs, damages, and expenses, and reasonable attorney fees arising out of, directly or indirectly, any claim of personal injury or death associated with such unintended or unauthorized use, even if such claim alleges that ON Semiconductor was negligent regarding the design or manufacture of the part. ON Semiconductor is an Equal Opportunity/Affirmative Action Employer. This literature is subject to all applicable copyright laws and is not for resale in any manner.

## PUBLICATION ORDERING INFORMATION

### LITERATURE FULFILLMENT:

Email Requests to: [orderlit@onsemi.com](mailto:orderlit@onsemi.com)

ON Semiconductor Website: [www.onsemi.com](http://www.onsemi.com)

### TECHNICAL SUPPORT

North American Technical Support:  
Voice Mail: 1 800-282-9855 Toll Free USA/Canada  
Phone: 011 421 33 790 2910

Europe, Middle East and Africa Technical Support:

Phone: 00421 33 790 2910

For additional information, please contact your local Sales Representative