

Features

- R_0 : 1000 Ω
- TCR 3850ppm/K
- Application temperature -50°C...600°C
- Resistance tolerance $\pm 0.12\%$
- Size 1.2 x 1.6 x 1.1 mm³ (width/length/height)
- Gold coated nickel wire, 10 mm length, 0.2 mm diameter

Applications

- Temperature feedback control
- White goods
- Industrial applications
- Automotive
- Medical
- Sensing element for plug-in probes
- HVAC
- ...

PTFP102B1G0

Platinum Temperature Sensor

Pt1000, 1.2x1.6, Class B, PTFP102B1G0

Product Description

This sensor is a resistance temperature detector (RTD) using a platinum resistor as sensing element. This platinum resistor consists of a structured platinum film on a ceramic substrate, passivated by a glass cover. The connection wires are protected with glass ceramic on the welding area. The material for the connection wire is gold coated nickel wire.

The characteristic curve of this Platinum RTD complies with DIN EN 60751. The usage of Platinum as resistive material guarantees high long term stability.

Due to relative small outline and low mass this RTD has a low time constant; therefore it is a suitable solution for fast and precise feedback control systems.

The sensor is designed for temperature applications up to 600°C.

Sensors are packed as bulk goods in blister box.

- Platinum Temperature Sensor
- Conformal to DIN EN 60751
- Global interchangeability
- Wide temperature range
- Fast response time
- Class B (F0.3) tolerance
- Very small outline dimensions
- Gold coated nickel lead wires
- Blister box packing

PTFP102B1G0

Platinum Temperature Sensor

Sensor properties

Parameter	Symbol	Condition	Min	Typ	Max	Unit
Nominal Resistance at 0 °C	R ₀	Class B (F0.3)	998.8	1000.0	1001.2	Ω
Temperature Coefficient of Resistance	TCR	0 °C, 100 °C		3850		ppm/°C
Tolerance Temperature Range *		Class B (F0.3)	-50		600	°C
Self-Heating Coefficient in air, flow: 1 m/s				0.6		°C/mW
Response Time Water Flow: 0.4 m/s	τ _{W,0.9}			0.15		s
Response Time Air Flow: 1 m/s	τ _{A,0.9}			6		s
Measuring Current		Class B (F0.3)			0.4	mA
Lead wire Au-coated Ni-wire		Diameter length		0.2 10		mm mm

*possible operating temperature range is, -200°C to +600°C for elements with Au-coated Ni wire.

Specified accuracy is not guaranteed if the sensor is exposed to temperatures outside the specified tolerance temperature range.

Calculation Formulas

The calculation formulas of this Pt-RTD are defined in DIN EN 60751 as following:

$$\text{For } T \geq 0 \text{ °C: } R(T) = R_{(0)} \cdot (1 + a \cdot T + b \cdot T^2)$$

$$\text{For } T < 0 \text{ °C: } R(T) = R_{(0)} \cdot [1 + a \cdot T + b \cdot T^2 + c \cdot (T - 100 \text{ °C}) \cdot T^3]$$

$$\text{Polynomial coefficients: } a = 3.9083\text{E-}03 \quad b = -5.775\text{E-}07 \quad c = -4.183\text{E-}12$$

$$\text{Tolerances: Class B (F 0.3): } \pm (0.3 + 0.005 \cdot |T/\text{°C}|) \text{ °C} \quad (-50 \dots +600 \text{ °C})$$

PTFP102B1G0

Platinum Temperature Sensor

Mechanical Dimensions

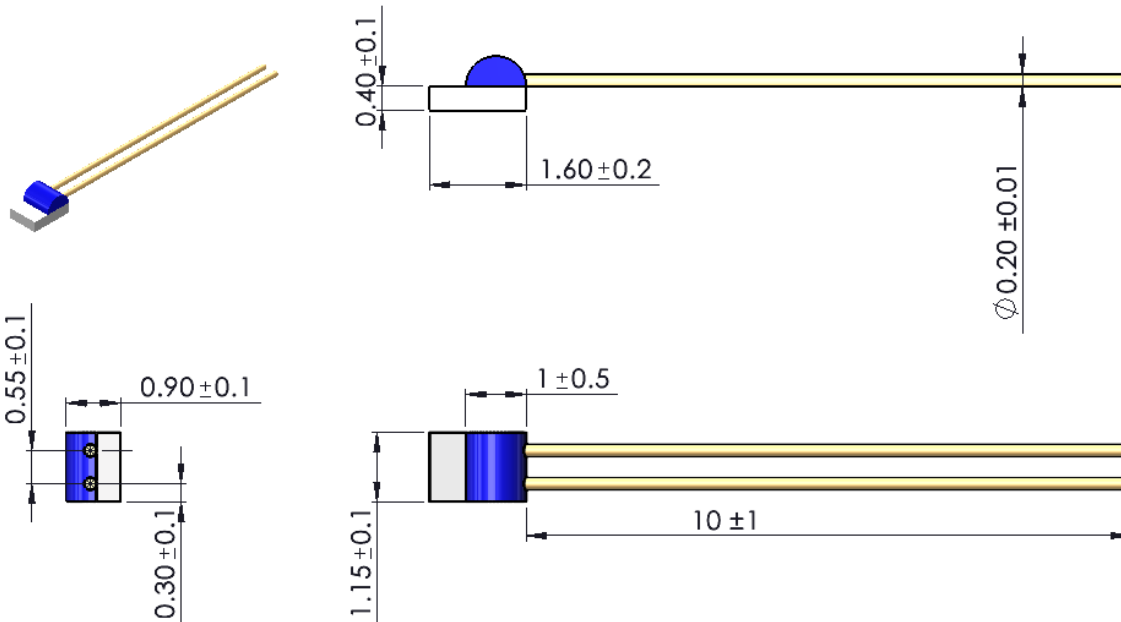

Figure 1: Mechanical dimensions of Platinum Temperature Sensor

Ordering Information

Description	Part Number	Configuration information
Pt1000, 1.2x1.6, Class B, PTFP102B1G0	NB-PTCO-040	1000 Ohms, 1.2mm x 1.6mm x 1.1 mm, F 0.3 (B), 10mm Au-coated Ni-wire

Packing and Minimum Order Quantity

Packing	PCS per Packing Unit	MOQ
Transparent Blister Box 80(120)mm x 50(60)mm x 20mm	500 (bulk)	500

NORTH AMERICA

Tel +1 800 522 6752

EUROPE

Tel +31 73 624 6999

ASIA

Tel +86 0400 820 6015

te.com/sensors

TE Connectivity, TE, TE Connectivity (logo) and Every Connection Counts are trademarks. All other logos, products and/or company names referred to herein might be trademarks of their respective owners

The information given herein, including drawings, illustrations and schematics which are intended for illustration purposes only, is believed to be reliable. However, TE Connectivity makes no warranties as to its accuracy or completeness and disclaims any liability in connection with its use. TE Connectivity's obligations shall only be as set forth in TE Connectivity's Standard Terms and Conditions of Sale for this product and in no case will TE Connectivity be liable for any incidental, indirect or consequential damages arising out of the sale, resale, use or misuse of the product. Users of TE Connectivity products should make their own evaluation to determine the suitability of each such product for the specific application.

© 2022 TE Connectivity Corporation. All Rights Reserved.

Version # 04/2022

