

# Surface Mount Aluminum Electrolytic Capacitors NACK Series

- CYLINDRICAL V-CHIP CONSTRUCTION FOR SURFACE MOUNTING
- VERY LOW IMPEDANCE
- WIDE TEMPERATURE RANGE (-55 +105°C)
- REDUCED SIZE
- DESIGNED FOR AUTOMATIC MOUNTING AND REFLOW SOLDERING
- MEETS THE REQUIREMENTS OF AEC-Q200\*

\*Contact NIC for supporting test data

See **NAZT** for  
New Designs

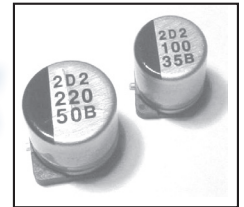

**RoHS  
Compliant**  
includes all homogeneous materials

\*See Part Number System for Details

Rated Voltage Range	6.3 ~ 100Vdc										
Rated Capacitance Range	3.3 ~ 6,800µF										
Operating Temperature Range	-55°C ~ +105°C										
Capacitance Tolerance	±20%(M)										
Maximum Leakage Current after 2 minutes @ 20°C	0.01CV or 3µA, whichever is greater										
Maximum Tanδ @ 120Hz/20°C	W.V. (Vdc)		6.3	10	16	25	35	50	63	80	100
	S.V. (Vdc)		8.0	13	20	32	44	63	79	100	125
	All Case Sizes	C ≤ 1,000µF	0.26	0.19	0.16	0.14	0.12	0.10	0.08	0.08	0.07
		C = 2,200µF	-	0.21	-	0.16	-	-	-	-	-
		C = 3,300µF	0.30	-	0.20	0.18	-	-	-	-	-
C = 4,700µF		-	0.25	0.22	-	-	-	-	-	-	
Low Temperature Stability Impedance Ratio @ 120Hz	Z -25°C/Z +20°C		2	2	2	2	2	2	2	2	2
	Z -40°C/Z +20°C		3	3	3	3	3	3	3	3	3
	Z -55°C/Z +20°C		4	4	4	3	3	3	3	3	3
Load Life Test @ 105°C 4 ~ 10mm Dia. 2,000 Hours 8x10.5mm 5,000 (Opt.) 10x10.5mm 5,000 (Opt.) 12.5 ~ 18mm Dia. 5,000 Hours	Capacitance Change		Within ±30% of initial measured value								
	Tanδ		Less than 200% of specified maximum value								
	Leakage Current		Less than specified maximum value								

Cap (µF)	Code	Working Voltage (Vdc)									
		6.3	10	16	25	35	50	63	80	100	
3.3	3R3	-	-	-	-	-	-	-	5x6.1	-	
4.7	4R7	-	-	-	-	4x6.1	4x6.1	5x6.1	6.3x6.1	-	
10	100	-	-	4x6.1	4x6.1	4x6.1	5x6.1	6.3x6.1	6.3x8	-	
									8x6.5	-	
22	220	4x6.1	4x6.1	4x6.1	5x6.1	5x6.1	6.3x6.1	6.3x8	8x10.5	8x10.5	
									8x6.5		
33	330	-	4x6.1	-	5x6.1	6.3x1	6.3x8	8x10.5	8x10.5	10x10.5	
47	470	4x6.1	-	5x6.1	6.3x6.1	6.3x6.1	6.3x8	8x10.5	10x10.5	12.5x14	
68	680	-	-	6.3x6.1	6.3x6.1	6.3x8	-	8x10.5	12.5x14	12.5x14	
100	101	5x6.1	-	6.3x6.1	6.3x8	6.3x8	8x10.5	10x10.5	12.5x14	16x17	
150	151	-	6.3x6.1	6.3x8	8x10.5	8x10.5	10x10.5	-	12.5x14	16x17	
220	221	6.3x6.1	6.3x8	6.3x8	8x10.5	8x10.5	10x10.5	12.5x14	-	-	
330	331	6.3x8	8x10.5	8x10.5	8x10.5	10x10.5	12.5x14	-	16x17	18x17	
390	391	-	-	-	-	-	12.5x14	-	-	-	
470	471	8x10.5	8x10.5	8x10.5	10x10.5	12.5x14	16x17	16x17	-	-	
560	561	-	-	-	-	-	-	-	-	-	
680	681	-	8x10.5	10x10.5	-	12.5x14	16x17	-	-	-	
1000	102	8x10.5	10x10.5	-	12.5x14	16x17	16x17	-	-	-	
1500	152	10x10.5	-	12.5x14	-	16x17	-	-	-	-	
2200	222	-	12.5x14	-	16x17	-	-	-	-	-	
3300	332	12.5x14	-	16x17	-	-	-	-	-	-	
4700	472	-	16x17	-	-	-	-	-	-	-	
6800	682	16x17	-	-	-	-	-	-	-	-	

  Available in "Y" Control Option (for Automotive Equipment)



# Surface Mount Aluminum Electrolytic Capacitors NACK Series

## STANDARD VALUES, CASE SIZES AND SPECIFICATIONS

NIC Part Number*	Cap. (μF)	W.V. (Vdc)	Dissipation Factor (Tan δ)	Max. Ripple Current (mA) +105°C/100KHz	Max. Impedance (Ω) +20°C/100KHz	Load Life Hours @ +105°C
NACK220M6.3V4x6.1TR13F	22	6.3	0.26	90	1.35	2,000
NACK470M6.3V4x6.1TR13F	47		0.26	90	1.35	2,000
NACK470M6.3V5x6.1TR13F			0.26	160	0.70	2,000
NACK101M6.3V5x6.1TR13F	100		0.26	160	0.70	2,000
NACK101M6.3V6.3x6.1TR13F			0.26	240	0.36	2,000
NACK221M6.3V6.3x6.1TR13F	220		0.26	240	0.36	2,000
NACK331M6.3V6.3x8TR13F	330		0.26	280	0.34	2,000
NACK331M6.3V8x6.5TR13F			0.26	300	0.26	2,000
NACK471M6.3V8x10.5TR13F	470		0.26	600	0.16	2,000
NACK471M6.3V8x10.5TR13EF	470		0.26	600	0.16	5,000
NACK102M6.3V8x10.5TR13F	1000		0.26	600	0.16	2,000
NACK102M6.3V8x10.5TR13EF	1000		0.26	600	0.16	5,000
NACK152M6.3V10x10.5TR13F	1500		0.28	850	0.08	2,000
NACK152M6.3V10x10.5TR13F	1500		0.28	850	0.08	
NACK332M6.3V12.5x14TR13F	3300		0.30	1100	0.06	5,000
NACK682M6.3V16x17TR15F	6800		0.36	1800	0.035	5,000
NACK220M10V4x6.1TR13F	22	10	0.19	90	1.35	2,000
NACK330M10V4x6.1TR13F	33		0.19	90	1.35	2,000
NACK330M10V5x6.1TR13F			0.19	160	0.70	2,000
NACK151M10V6.3x6.1TR13F	150		0.19	240	0.36	2,000
NACK221M10V6.3x8TR13F	220		0.19	160	0.34	2,000
NACK221M10V8x6.5TR13F			0.19	300	0.26	2,000
NACK331M10V8x10.5TR13F	330		0.19	600	0.16	2,000
NACK331M10V8x10.5TR13F	330		0.19	600	0.16	
NACK471M10V8x10.5TR13F	470		0.19	600	0.16	2,000
NACK471M10V8x10.5TR13F	470		0.19	600	0.16	
NACK681M10V8x10.5TR13F	680		0.19	600	0.16	2,000
NACK681M10V8x10.5TR13F	680		0.19	600	0.16	
NACK102M10V10x10.5TR13F	1000		0.19	850	0.08	2,000
NACK102M10V10x10.5TR13F	1000		0.19	850	0.08	
NACK222M10V12.5x14TR13F	2200		0.21	1100	0.06	5,000
NACK472M10V16x17TR15F	4700		0.25	1800	0.035	5,000
NACK100M16V4x6.1TR13F	10	16	0.16	90	1.35	2,000
NACK220M16V4x6.1TR13F	22		0.16	90	1.35	2,000
NACK220M16V5x6.1TR13F			0.16	160	0.70	2,000
NACK470M16V5x6.1TR13F	47		0.16	160	0.70	2,000
NACK470M16V6.3x6.1TR13F			0.16	240	0.36	2,000
NACK680M16V6.3x6.1TR13F	68		0.16	240	0.36	2,000
NACK101M16V6.3x6.1TR13F	100		0.16	240	0.36	2,000
NACK151M16V6.3x8TR13F	150		0.16	280	0.34	2,000
NACK221M16V6.3x8TR13F	220		0.16	280	0.34	2,000
NACK221M16V8x6.5TR13F			0.16	300	0.26	2,000
NACK331M16V8x10.5TR13F	330		0.16	600	0.16	2,000
NACK331M16V8x10.5TR13F	330		0.16	600	0.16	
NACK471M16V8x10.5TR13F	470		0.16	600	0.16	2,000
NACK471M16V8x10.5TR13F	470		0.16	600	0.16	
NACK681M16V10x10.5TR13F	680		0.16	850	0.08	2,000
NACK681M16V10x10.5TR13F	680		0.16	850	0.08	
NACK152M16V12.5x14TR15F	1500	0.18	1100	0.06	5,000	
NACK332M16V16x17TR15F	3300	0.20	1800	0.035	5,000	
NACK100M25V4x6.1TR13F	10	25	0.14	90	1.35	2,000
NACK220M25V5x6.1TR13F	22		0.14	160	0.70	2,000
NACK330M25V5x6.1TR13F	33		0.14	160	0.70	2,000
NACK330M25V6.3x6.1TR13F			0.14	240	0.36	2,000
NACK470M25V6.3x6.1TR13F	47		0.14	240	0.36	2,000
NACK680M25V6.3x6.1TR13F	68		0.14	240	0.36	2,000
NACK101M25V6.3x8TR13F	100		0.14	280	0.34	2,000
NACK101M25V6.3x8TR13F	100		0.14	280	0.34	

Available in "Y" Control Option (for Automotive Equipment)

\*See part numbering system for how to denote WT termination style



# Surface Mount Aluminum Electrolytic Capacitors NACK Series

## STANDARD VALUES, CASE SIZES AND SPECIFICATIONS

NIC Part Number*	Cap. (μF)	W.V. (Vdc)	Dissipation Factor (Tan δ)	Max. Ripple Current (mA) +105°C/100KHz	Max. Impedance (Ω) +20°C/100KHz	Load Life Hours @ +105°C
NACK101M25V8x6.5TR13F	100	25	0.14	300	0.26	2,000
NACK151M25V8x10.5TR13F	150		0.14	600	0.16	2,000
NACK151M25V8x10.5TR13F	150		0.14	600	0.16	
NACK221M25V8x10.5TR13F	220		0.14	600	0.16	2,000
NACK221M25V8x10.5TR13F	220		0.14	600	0.16	
NACK331M25V8x10.5TR13F	330		0.14	600	0.16	2,000
NACK331M25V8x10.5TR13F	330		0.14	600	0.16	
NACK471M25V10x10.5TR13F	470		0.14	850	0.08	2,000
NACK471M25V10x10.5TR13F	470		0.14	850	0.08	
NACK102M25V12.5x14TR15F	1000		0.14	1100	0.06	5,000
NACK222M25V16x17TR15F	2200	0.16	1800	0.035	5,000	
NACK4R7M35V4x6.1TR13F	4.7	35	0.12	90	1.35	2,000
NACK100M35V4x6.1TR13F	10		0.12	90	1.35	2,000
NACK100M35V5x6.1TR13F			0.12	160	0.70	2,000
NACK220M35V5x6.1TR13F	22		0.12	160	0.70	2,000
NACK330M35V6.3x1TR13F	33		0.12	240	0.36	2,000
NACK470M35V6.3x6.1TR13F	47		0.12	240	0.36	2,000
NACK680M35V6.3x8TR13F	68		0.12	280	0.34	2,000
NACK101M35V6.3x8TR13F	100		0.12	280	0.34	2,000
NACK101M35V8x10.5TR13F			0.12	600	0.16	2,000
NACK101M35V8x10.5TR13F	100		0.12	600	0.16	
NACK151M35V8x10.5TR13F	150		0.12	600	0.16	2,000
NACK151M35V8x10.5TR13F	150		0.12	600	0.16	
NACK221M35V8x10.5TR13F	220		0.12	600	0.16	2,000
NACK221M35V8x10.5TR13F	220		0.12	600	0.16	
NACK331M35V10x10.5TR13F	330		0.12	850	0.08	2,000
NACK331M35V10x10.5TR13F	330		0.12	850	0.08	
NACK471M35V12.5x14TR15F	470		0.12	1100	0.06	5,000
NACK681M35V12.5x14TR15F	680		0.12	1100	0.06	5,000
NACK102M35V16x17TR15F	1000		0.12	1800	0.035	5,000
NACK152M35V16x17TR15F	1500		0.12	1800	0.035	5,000
NACK4R7M50V4x6.1TR13F	4.7	50	0.10	60	2.9	2,000
NACK100M50V5x6.1TR13F	10		0.10	85	1.52	2,000
NACK100M50V6.3x6.1TR13F			0.10	165	0.88	2,000
NACK220M50V6.3x6.1TR13F	22		0.10	165	0.88	2,000
NACK330M50V6.3x8TR13F	33		0.10	195	0.68	2,000
NACK330M50V8x6.5TR13F			0.10	195	0.68	2,000
NACK470M50V6.3x8TR13F	47		0.10	195	0.68	2,000
NACK470M50V8x6.5TR13F			0.10	195	0.68	2,000
NACK101M50V8x10.5TR13F	100		0.10	350	0.34	2,000
NACK101M50V8x10.5TR13F	100		0.10	350	0.34	
NACK151M50V10x10.5TR13F	150		0.10	670	0.18	2,000
NACK151M50V10x10.5TR13F	150		0.10	670	0.18	
NACK221M50V10x10.5TR13F	220		0.10	670	0.18	2,000
NACK221M50V10x10.5TR13F	220		0.10	670	0.18	
NACK331M50V12.5x14TR15F	330		0.10	900	0.12	5,000
NACK391M50V12.5x14TR13F	390		0.10	900	0.12	5,000
NACK471M50V16x17TR15F	470		0.10	1610	0.073	5,000
NACK681M50V16x17TR15F	680		0.10	1610	0.073	5,000
NACK102M50V16x17TR15F	1000		0.10	1610	0.073	5,000
NACK4R7M63V5x6.1TR13F	4.7		63	0.08	50	3.0
NACK100M63V6.3x6.1TR13F	10	0.08		80	1.5	2,000
NACK220M63V6.3x8TR13F	22	0.08		120	1.2	2,000
NACK220M63V8x6.5TR13F		0.08		120	1.2	2,000
NACK330M63V8x10.5TR13F	33	0.08		250	0.65	2,000
NACK470M63V8x10.5TR13F	47	0.08		250	0.65	2,000

Available in "Y" Control Option (for Automotive Equipment)

\*See part numbering system for how to denote WT termination style



# Surface Mount Aluminum Electrolytic Capacitors NACK Series

## STANDARD VALUES, CASE SIZES AND SPECIFICATIONS

NIC Part Number*	Cap. (μF)	W.V. (Vdc)	Dissipation Factor (Tan δ)	Max. Ripple Current (mA) +105°C/100KHz	Max. Impedance (Ω) +20°C/100KHz	Load Life Hours @ +105°C
NACK680M63V8x10.5TR13F	68	63	0.08	250	0.65	2,000
NACK101M63V10x10.5TR13F	100		0.08	400	0.35	2,000
NACK221M63V12.5x14TR13F	220		0.08	800	0.16	5,000
NACK471M63V16x17TR15F	470		0.08	1410	0.082	5,000
NACK3R3M80V5x6.1TR13F	3.3	80	0.08	25	5.0	2,000
NACK4R7M80V6.3x6.1TR13F	4.7		0.08	40	3.0	2,000
NACK100M80V6.3x8TR13F	10		0.08	60	2.4	2,000
NACK100M80V8x6.5TR13F			0.08	60	2.4	2,000
NACK220M80V8x10.5TR13F	22		0.08	130	1.3	2,000
NACK330M80V8x10.5TR13F	33		0.08	130	1.3	2,000
NACK470M80V10x10.5TR13F	47		0.08	200	0.7	2,000
NACK680M80V12.5x14TR15F	68		0.08	500	0.32	5,000
NACK101M80V12.5x14TR15F	100		0.08	500	0.32	5,000
NACK151M80V12.5x14TR15F	150		0.08	500	0.32	5,000
NACK331M80V16x17TR15F	330		0.08	793	0.17	5,000
NACK220M100V8x10.5TR13F	22		100	0.07	130	1.3
NACK330M100V10x10.5TR13F	33	0.07		200	0.7	2,000
NACK470M100V12.5x14TR15F	47	0.07		500	0.32	5,000
NACK680M100V12.5x14TR15F	68	0.07		500	0.32	5,000
NACK101M100V16x17TR15F	100	0.07		793	0.17	5,000
NACK151M100V16x17TR15F	150	0.07		793	0.17	5,000
NACK331M100V18x17TR13F	330	0.07		917	0.153	5,000

Available in "Y" Control Option (for Automotive Equipment)

\*See part numbering system for how to denote WT termination style

Frequency	60Hz	120Hz	1KHz	10KHz	100KHz
Correction Factor	0.7	0.75	0.9	0.95	1.0

### PART NUMBER SYSTEM

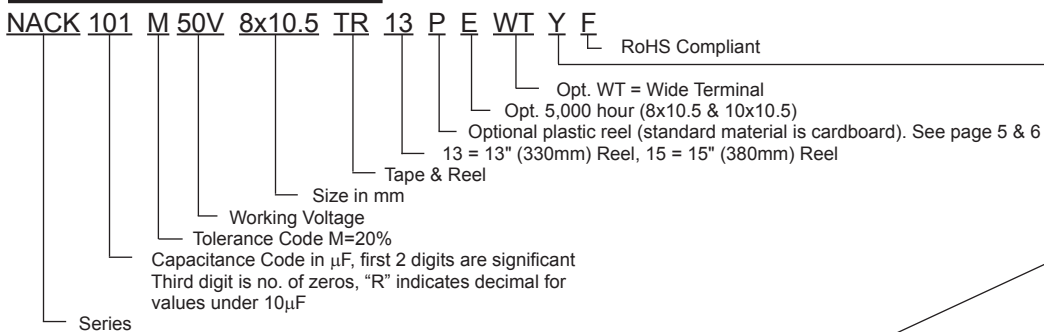

Optional: Suitable for automotive equipment, sourced to special production and inspection at TS-16949 certified production site

Review & Compare Reflow Soldering Heat Limits  
V-chip SMT Aluminum Electrolytic Capacitors  
[www.niccomp.com/RSL](http://www.niccomp.com/RSL)

### PRECAUTIONS

Please review the notes on correct use, safety and precautions found at <https://www.niccomp.com/resource/files/aluminum/AlumApplInfoCautions.pdf>  
If in doubt or uncertainty, please review your specific application - process details with NIC's technical support personnel: [tpmg@niccomp.com](mailto:tpmg@niccomp.com)



# Surface Mount Aluminum Electrolytic Capacitors NACK Series

## COMPONENT DIMENSIONS

Case Size	D $\phi$ $\pm$ 0.5	L max.	A, B	H max.	I $\pm$ 0.3	P $\pm$ 0.3	W	K	R	S	T
4x6.1	4.0	6.1	4.3 $\pm$ 0.2	5.5	1.8	1.0	0.65 $\pm$ 0.15	0.35 $\pm$ 0.2	-	-	-
5x6.1	5.0	6.1	5.3 $\pm$ 0.2	6.5	2.2	1.5	0.65 $\pm$ 0.15	0.35 $\pm$ 0.2	-	-	-
6.3x6.1	6.3	6.1	6.6 $\pm$ 0.2	7.8	2.6	1.8	0.70 $\pm$ 0.20	0.35 $\pm$ 0.2	-	-	-
6.3x8	6.3	8.0	6.6 $\pm$ 0.2	7.8	2.6	1.8	0.65 $\pm$ 0.15	0.35 $\pm$ 0.2	-	-	-
8x6.5	8.0	6.5	8.3 $\pm$ 0.2	9.5	3.4	2.2	0.65 $\pm$ 0.15	0.35 $\pm$ 0.2	-	-	-
8x6.5WT	8.0	6.8	8.3 $\pm$ 0.2	9.5	3.4	2.2	0.70 $\pm$ 0.10	0.35 $\pm$ 0.2	0.70 $\pm$ 0.2	5.3 $\pm$ 0.2	1.7 $\pm$ 0.2
8x10.5	8.0	10.5	8.3 $\pm$ 0.2	10.0	3.1	3.1	0.90 $\pm$ 0.20	0.70 $\pm$ 0.2/-0.5	-	-	-
8x10.5WT	8.0	10.8	8.3 $\pm$ 0.2	10.0	3.4	3.1	0.90 $\pm$ 0.20	0.70 $\pm$ 0.2	0.70 $\pm$ 0.2	5.3 $\pm$ 0.2	1.3 $\pm$ 0.2
10x10.5	10.0	10.5	10.3 $\pm$ 0.2	12.0	3.2	4.6	1.05 $\pm$ 0.35	0.70 $\pm$ 0.2/-0.5	-	-	-
10x10.5WT	10.0	10.8	10.3 $\pm$ 0.2	12.0	3.5	4.6	1.05 $\pm$ 0.35	0.70 $\pm$ 0.2	0.70 $\pm$ 0.2	6.9 $\pm$ 0.2	1.3 $\pm$ 0.2
12.5x14	12.5	14.0	13.2 $\pm$ 0.6	15.0	4.5	4.6	1.00 $\pm$ 0.40	0.70 $\pm$ 0.3/-0.5	-	-	-
12.5x14WT	12.5	14.3	13.5 $\pm$ 0.2	15.0	4.7	4.4	1.20 $\pm$ 0.30	0.70 $\pm$ 0.3	2.2 $\pm$ 0.2	7.1 $\pm$ 0.2	2.4 $\pm$ 0.2
16x17	16.0	17.0	16.7 $\pm$ 0.6	19.0	5.2	6.9	1.50 $\pm$ 0.60	0.70 $\pm$ 0.3/-0.4	-	-	-
16x17WT	16.0	17.5	17.0 $\pm$ 0.2	20.0	5.5	6.9	1.65 $\pm$ 0.45	0.70 $\pm$ 0.3/-0.4	3.0 $\pm$ 0.2	9.0 $\pm$ 0.2	1.9 $\pm$ 0.2
18x17	18.0	17.0	19.0 $\pm$ 0.2	21.0	6.7	6.7	1.20 $\pm$ 0.30	0.70 $\pm$ 0.3	-	-	-
18x17WT	18.0	17.3	19.0 $\pm$ 0.2	21.0	6.7	6.7	1.40 $\pm$ 0.20	0.70 $\pm$ 0.3	3.0 $\pm$ 0.2	11.0 $\pm$ 0.2	1.9 $\pm$ 0.2

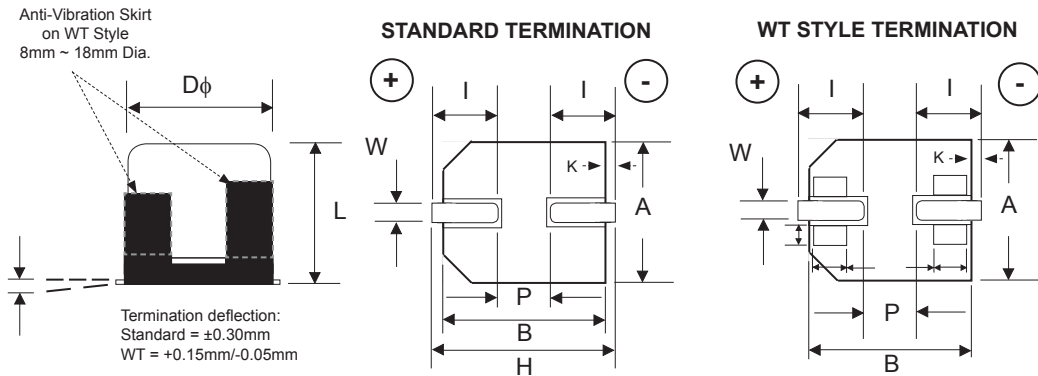

### RECOMMENDED LAND PATTERN (mm) STANDARD TERMINAL

Case Dia.	a	b	c
4x6.1	1.0	2.6	1.8
5x6.1	1.4	3.0	1.8
6.3x6.1	2.1	3.5	1.8
6.3x8	2.1	3.5	1.8
8x6.5	2.2	4.5	1.6
8x10.5	2.8	4.1	2.2
10x10.5	4.5	4.5	2.5
12.5x14	4.3	5.8	2.5
16x17	6.6	6.5	4.0
18x17	6.0	7.5	2.5

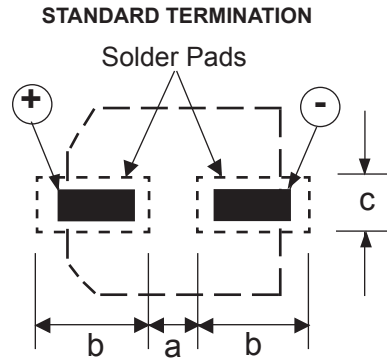

### RECOMMENDED LAND PATTERN (mm) WIDE TERMINAL

Case Dia.	d	e	f
8x6.5WT	1.8	4.1	5.0
8x10.5WT	2.7	4.0	4.7
10x10.5WT	3.9	4.4	4.7
12.5x14WT	3.9	6.0	2.5
16x17WT	4.7	8.4	9.6
18x17WT	4.7	8.4	9.6

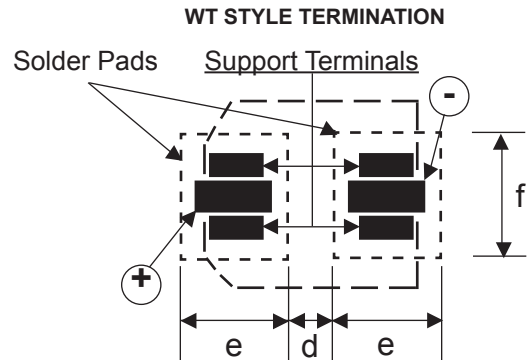

# Surface Mount Aluminum Electrolytic Capacitors NACK Series

WT (Wide Terminations) Anti-Vibration Test	
Test Method	Direction: X, Y, Z axis Frequency & Duration: 5 to 2000Hz reciprocation for 20 minutes, 2 hours each direction Peak to Peak Amplitude: 5mm Peak Acceleration: 30G Sweep Type: Log
Δ Capacitance	Within ± 10% of initial value
Tangent of Loss	≤ Specified value
Leakage Current	≤ Specified value

## CARRIER TAPE

Case Size	A ±0.5	B ±0.2	C ±0.3	D ±0.1	P ±0.1	T ±0.2
4x6.1	4.7	4.7	12.0	5.5	8.0	6.4
5x6.1	5.7	5.7	12.0	5.5	12.0	6.4
6.3x6.1	7.0	7.0	16.0	7.5	12.0	6.4
6.3x8	7.0	7.0	16.0	7.5	12.0	8.3
8x6.5	8.7	8.7	16.0	7.5	12.0	6.8
8x6.5WT						
8x10.5	8.7	8.7	24.0	7.5	12.0	11.1
8x10.5WT						
10x10.5	10.7	10.7	24.0	11.5	16.0	11.2
10x10.5WT						
12.5x14	13.2	13.2	32.0	14.2	24.0	14.2
12.5x14WT	14.0	14.0	32.0	14.2	24.0	14.2
16x17	17.5	17.5	44.0	20.2	28.0	17.5
16x17WT						
18x17	19.5	19.5	44.0	20.2	32.0	17.5
18x17WT						

## TR13 330mm (13") REEL

## TR15 380mm (15") REEL

(see page 8 for plastic reel specifications)

Case Size	W ±1.0	Quantity Per Reel	
		13" Reel	15" Reel
4x6.1	14.0	1,200 pcs	2,000 pcs
5x6.1	14.0	800 pcs	1,000 pcs
6.3x6.1	18.0	800 pcs	1,000 pcs
6.3x8	18.0	500 pcs	900 pcs
8x6.5	18.0	800 pcs	1,000 pcs
8x10.5	26.0	300 pcs	500 pcs
10x10.5	26.0	300 pcs	500 pcs
12.5x14	34.0	200 pcs*	250 pcs*
16x17	46.0	125 pcs*	200 pcs*
18x17	46.0	125 pcs	150 pcs

\*See specific part number in standard values tables for available reel diameter.

## TAPING SPECIFICATIONS (mm)

- Both Leader and Trailer tape: Minimum 40mm (1.57") empty carrier tape pockets.
- Leader tape: Approximately 20cm of cover tape at leader.
- Connection: Maximum 3 connections (slices) per reel.

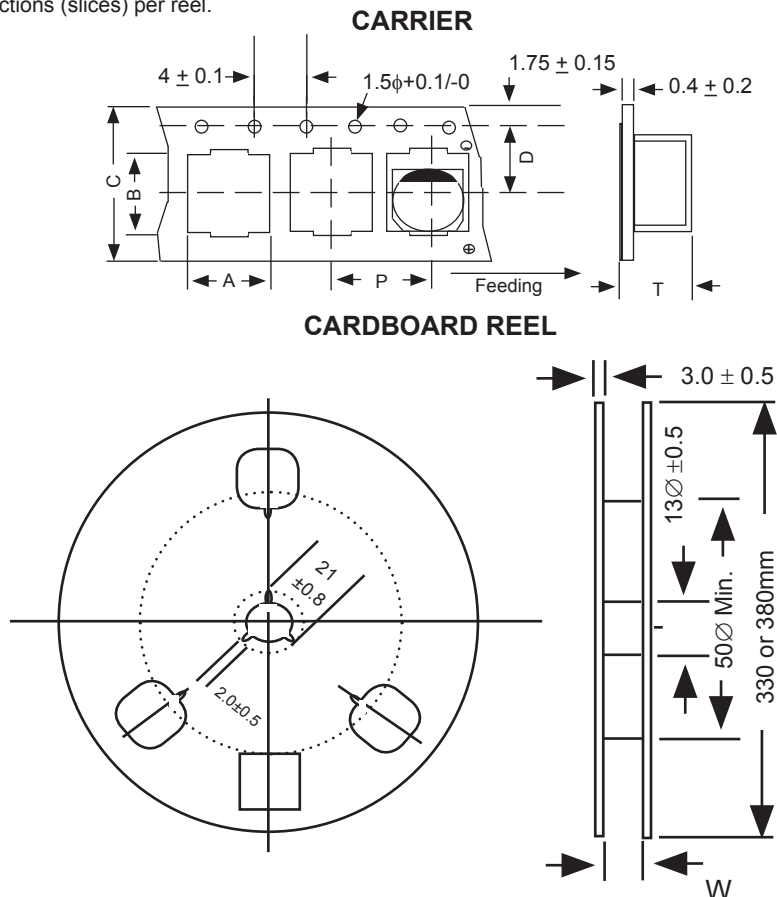

# Surface Mount Aluminum Electrolytic Capacitors NACK Series

## Optional V-Chip 13" (330mm) Plastic Reels (TR13P suffix)

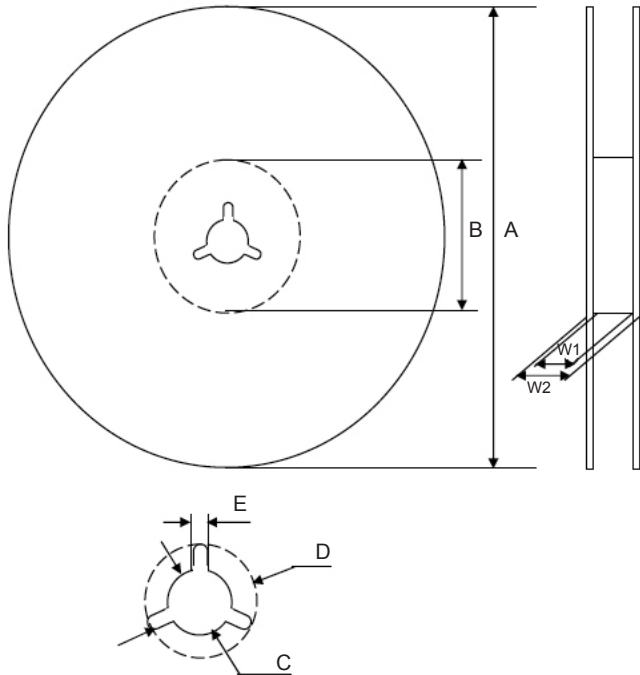

### Dimensions (mm)

Case Size	Tape Width	W1	W2
4x6.1, 5x6.1	12.0	12.4 ~ 14.4	15.5 ~ 20.0
6.3x6.1, 6.3x8, 8x6.5	16.0	16.4 ~ 18.4	19.5 ~ 24.0
8x10.5, 10x10.5	24.0	24.4 ~ 26.4	27.5 ~ 32.0
12.5x14	32.0	32.4 ~ 35.0	36.5 ~ 38.4
16x17, 18x17	44.0	44.4 ~ 47.0	48.2 ~ 50.4

Case Size	Tape Width	A	B	C	D	E
4x6.1, 5x6.1	12.0	φ330 ±2.0	φ50~105	φ13 ±0.5	φ21 ±1.0	2.0 ±0.5
6.3x6.1, 6.3x8, 8x6.5	16.0					
8x10.5, 10x10.5	24.0					
12.5x14	32.0					
16x17, 18x17	44.0					

Color
Black or Blue

## Optional V-Chip 15" (380mm) Plastic Reels (TR15P suffix)

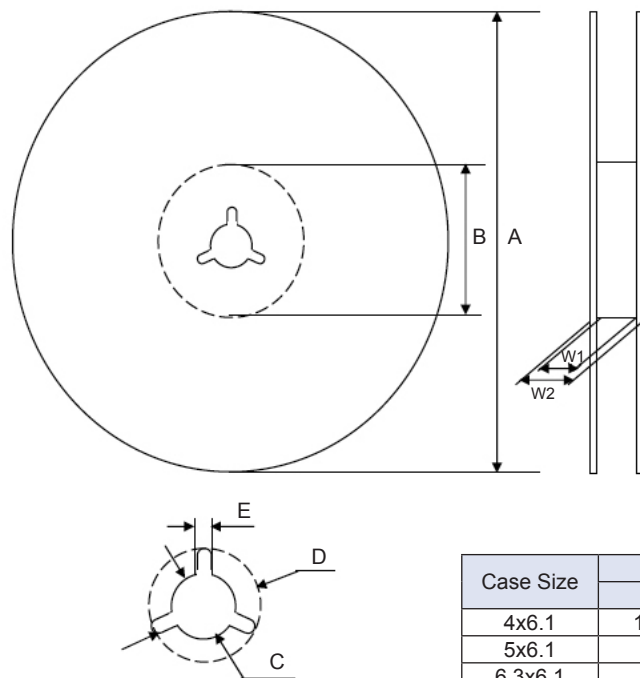

### Dimensions (mm)

Case Size	Tape Width	W1	W2
4x6.1, 5x6.1	12.0	12.5 ~ 14.0	15.5 ~ 20.0
6.3x6.1, 6.3x8, 8x6.5	16.0	16.5 ~ 18.0	19.5 ~ 24.0
8x10.5, 10x10.5	24.0	24.5 ~ 26.0	27.5 ~ 32.0
12.5x14	32.0	33.0 ~ 34.0	36.5 ~ 38.5
16x17, 18x17	44.0	45.0 ~ 46.0	48.5 ~ 50.5

Case Size	Tape Width	A	B	C	D	E
4x6.1, 5x6.1	12.0	φ380 ±2	φ80~105	φ13 ±0.5	φ21 ±1.0	2.0 ±0.5
6.3x6.1, 6.3x8, 8x6.5	16.0					
8x10.5, 10x10.5	24.0					
12.5x14	32.0					
16x17, 18x17	44.0					

Color
Black or Blue

Case Size	Quantity Per Reel	
	13" Reel	15" Reel
4x6.1	1,200 pcs	2,000 pcs
5x6.1	800 pcs	1,000 pcs
6.3x6.1	800 pcs	1,000 pcs
6.3x8	500 pcs	900 pcs
8x6.5	800 pcs	1,000 pcs
8x10.5	300 pcs	500 pcs
10x10.5	300 pcs	500 pcs
12.5x14	200 pcs*	250 pcs*
16x17	125 pcs*	200 pcs*
18x17	125 pcs	150 pcs

\*See specific part number in standard values tables for available reel diameter.

