

Single and Double Air Piloted

N1-SP
N2-SPN1-DP
N2-DP

Single and Double Solenoid

N1-SCD
N2-SCDN1-DCD
N2-DCDSolenoids shown here with
PVD1 (sold separately)

Designed For Long Life

Nova 4-way directional control valves offer state-of-the-art air valve design at a remarkably low price. Nova utilizes a single bonded rubber spool with finely ground sealing lands that travel only .047" ...less than 1/16 th of an inch! This economy of movement assures long valve life yet generates enough flow to power a 4" bore cylinder.

Large Air Flow With Dual Exhausts

1/4" NPTF ported Nova valves produce a large output flow of 57 cubic feet per minute at 100 PSI inlet pressure ($C_v=1.0$). Each output port has its own exhaust port so that individual exhaust control is possible.

Manual Override as Standard

All Nova valves are supplied with manual overrides so that valve actuation may be triggered without electricity or air to the pilots.

External Air Supply to Solenoid (E)

For solenoid actuation below the stated minimum pilot pressure or for vacuum applications, a 10-32 tapped external air supply allows the solenoid to be operated at different pressures than the power section.

Ordering Instructions

Single Valves: State model number and voltage, if applicable.

Stacked Valves: Add an "M" to the single valve model number and state voltage if applicable - specify number and type of valves in each stack. **Note:** Explosion proof coils may not be stacked next to each other because of their greater size.

External Pilot Supply: Add an "E" to the model number.

Isolator Discs: Specify isolator discs only if you will need to isolate valves within a stack.

Operating Parameters N1	Operating Parameters N2
Media: Air or Inert Gas	Media: Air or Inert Gas
Pressure: Vacuum to 120 PSI	Pressure: Vacuum to 120 PSI
Port Size: 1/8" NPTF	Port Size: 1/4" NPTF
Pilot Ports: 1/8" NPSF	Pilot Ports: 1/8" NPSF
Flow: $C_v = 0.7$ (single valves) $C_v = 0.9$ (stacked valves)	Flow: $C_v = 1.0$ (single valves) $C_v = 1.2$ (stacked valves)
Temperature: 0°F to 120°F	Temperature: 0°F to 120°F
Lubrication: Petroleum Base Oil	Lubrication: Petroleum Base Oil
Filtration: 40 Micron Minimum	Filtration: 40 Micron Minimum
Sol Response: 30-40 ms	Sol Response: 30-40 ms
Seals: Buna	Seals: Buna

Ordering Example:

NEW!

N1 = 1/8" ports
N1-SCD - M - 24VAC

Base Model _____
Stacking Option _____
Voltage _____

N2 = 1/4" ports
N2-SCD - M - 24VAC

Base Model _____
Stacking Option _____
Voltage _____

Nova Specifications

N1 Model	N2 Model	Actuator	Return	Description	Min. Pilot Pressure	Available Voltages		Wiring Type
						DC	AC	
N1-DP	N2-DP	Air Pilot	Air Pilot	Double Pressure Piloted	10PSI	-	-	-
N1-SP	N2-SP	Air Pilot	Spring	Single Pressure Piloted	40PSI	-	-	-
N1-DB	N2-DB	Bleed Pilot	Bleed Pilot	Double Bleed Piloted	40PSI	-	-	-
N1-HL	N2-HL	Hand Lever	Spring	Light 3lb. Touch	-	-	-	-
N1-PB	N2-PB	Push Button	Push Button	Detent	40PSI	-	-	-
N1-F4	N2-F4	Foot Pedal	Spring	Foot Valve w/Cover	-	-	-	-
N1-SCD*	N2-SCD*	Solenoid	Spring	DIN Connector Solenoid	40PSI	12-24	24-120-220-240	DIN*
N1-SX*	N2-SX*	Solenoid	Spring	Explosion Proof	40PSI	-	120	Conduit
N1-DCD*	N2-DCD*	Solenoid	Solenoid	DIN Connector Solenoids	10PSI	12-24	24-120-220-240	DIN*
N1-DX	N2-DX	Solenoid	Solenoid	Explosion Proof	10PSI	-	120	Conduit

* Connector not included on N2-SCD and N2-DCD. See "DIN Solenoid Connectors" on following page.

Double Push Button



N1-PB
N2-PB

Hand Lever



N1-HL
N2-HL

Foot Pedal

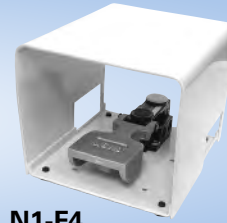

N1-F4
N2-F4

DIN Solenoid Connectors

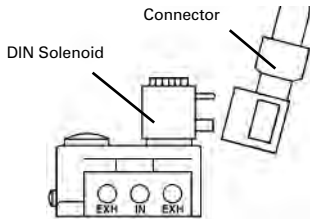

A DIN connector (ordered separately) quickly attaches to the solenoid's prongs and is secured by a single screw.

Model PVD1



Mead offers 3 types of 12mm industrial B-type DIN connectors to facilitate connections to the solenoid. Model PVD1 is a connector with a 1/2" conduit entry and no lead wires. Model PVD2 also has a 1/2" conduit entry but includes 20" of cabled lead wire. Model PVD3 is a strain relief connector that includes 72" of cabled wire. See page 68.

Dimensions

Basic Top View

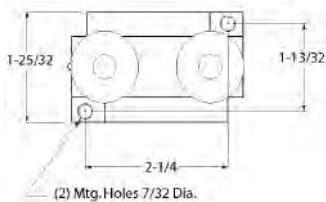

N1-HL & N2-HL

Models N1 & N2
SCD, DP, SP, DB, and PB

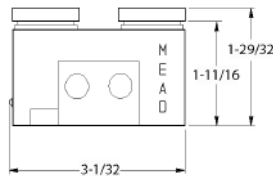

N1-SCD & N2-SCD (with connector)

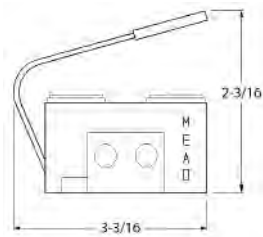

Stacks

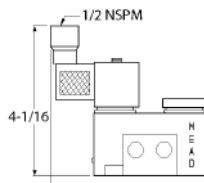

N2-F4

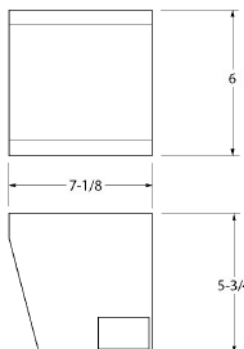
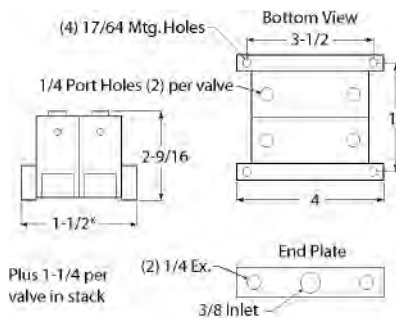

Stacking Options

If your application calls for the use of several valves, it is often advantageous to stack them. Because all valves within a stack are supplied air from a common source and are vented through common exhaust ports, plumbing time and fitting costs are greatly reduced.

Stacking also assures that your control valves are located centrally for more convenient trouble shooting and maintenance. Each stack valve body is attached only to its immediate neighbors so that valve additions, replacements, or deletions are easily achieved.

Flow Patterns

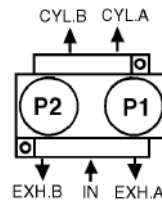

Single-actuated spring return models, including hand lever and foot pedal, have the inlet and Cyl. B ports connected when unactuated. On all double-actuated models, except (N1 or N2)-PB and (N1 or N2)-DB, signals at P1 cause output at Cyl. A and signals at P2 cause output at Cyl. B. On (N1 or N2)-PB and (N1 or N2)-DB models, the reverse occurs.

Easy To Repair

Nova valves are designed to permit complete replacement of all wearing parts in seconds without touching the piping or electrical wiring. All you need are a pair of snap ring pliers and a replacement spool.

Valve Symbols

N1-DP & N2-DP

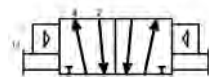

N2-F4

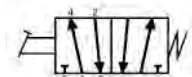

N1-SP & N2-SP



N1-PB & N2-PB



N1-DB & N2-DB



N1-SCD & N2-SCD

N1-SX & N2-SX



N1-HL & N2-HL



N1-DCD & N2-DCD

N1-DX & N2-DX

