

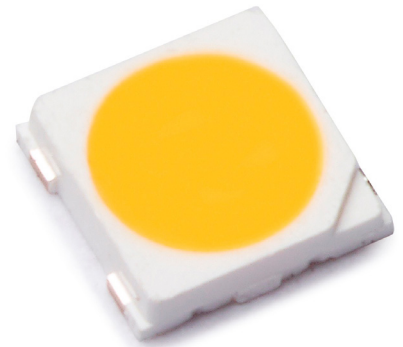

# LUXEON 3535L

High efficacy in a 3535 package with full range of CCTs and CRIs

The LUXEON 3535L delivers optimized performance in combination with the Quality of Light needed for distributed light source applications. In addition to offering specified correlated color temperature and color rendering combinations, LUXEON 3535L is available in three performance levels. These LEDs boast the efficacy and reliability required by the indoor and outdoor illumination markets.



## FEATURES AND BENEFITS

Industry standard package enables drop-in replacement for existing 3535 packages

Maximum drive current of 200mA delivers superior lumens for reduced LED count

1/6<sup>th</sup> and 1/7<sup>th</sup> ANSI color binning delivers tight color control

Enables T<sub>s</sub> points of 105°C which allows for higher broad temperature

Full range of CCTs and minimum CRI configurations for design flexibility

UL-recognized component [E352519]

## PRIMARY APPLICATIONS

Architectural

Downlights

Indoor Area Lighting

Lamps

Specialty Lighting

# Table of Contents

|   |    |
|---|----|
| General Information .....                       | 2  |
| Product Nomenclature .....                      | 2  |
| Average Lumen Maintenance Characteristics ..... | 2  |
| Environmental Compliance .....                  | 2  |
| Product Selection .....                         | 3  |
| Optical Characteristics .....                   | 4  |
| Electrical Characteristics .....                | 5  |
| Absolute Maximum Ratings .....                  | 5  |
| JEDEC Moisture Sensitivity .....                | 5  |
| Reflow Soldering Characteristics .....          | 6  |
| Mechanical Dimensions .....                     | 7  |
| Solder Pad Design .....                         | 8  |
| Assembly Precautions .....                      | 8  |
| Typical Performance Curves .....                | 9  |
| Light Output Characteristics .....              | 11 |
| Luminous Efficacy Characteristics .....         | 12 |
| Forward Current Characteristics .....           | 12 |
| Typical Radiation Patterns .....                | 13 |
| Emitter Pocket Tape Packaging .....             | 14 |
| Emitter Reel Packaging .....                    | 14 |
| Product Binning and Labeling .....              | 15 |
| Color Bin Structure .....                       | 17 |

# General Information

## Product Nomenclature

LUXEON 3535L Illumination emitters are tested and binned at 100mA, with current pulse duration of 20ms. All characteristic charts where the solder pad is kept at constant temperature (25°C typically) are measured with current pulse duration of 20ms.

The part number designations for the MXA8 series is explained as follows:

M X A D - E F G H - I J K L

Where:

D — designates minimum CRI performance (7 = 70 minimum and 8 = 80 minimum)

E — designates radiation pattern (value P = Lambertian)

F — designates color (W = White)

G & H — designates nominal ANSI CCT (30 = 3000K and 40 = 4000K)

I, J, K & L — additional part number designation

Therefore products in this series with minimum CRI value of 80, CCT of 4000K will have the part numbering scheme:

M X A 8 - P W 4 0

## Average Lumen Maintenance Characteristics

Lumen maintenance for solid-state lighting devices (LEDs) is typically defined in terms of the percentage of initial light output remaining after a specified period of time.

## Environmental Compliance

Lumileds is committed to providing environmentally friendly products to the solid-state lighting market. LUXEON mid-power LEDs are compliant to the European Union directives on the restriction of hazardous substances in electronic equipment, namely REACH and the RoHS directive. Lumileds will not intentionally add the following restricted materials to these LEDs: lead, mercury, cadmium, hexavalent chromium, polybrominated biphenyls (PBB) or polybrominated diphenyl ethers (PBDE).

# Product Selection

## Product Selection for LUXEON 3535L LEDs

Solder Pad Temperature = 25°C, Test Current = 100mA

Table 1.

| Nominal CCT | Minimum CRI | Typical CRI | R9    | Min Luminous Flux (lm) $\Phi_v$ | Typ Luminous Flux (lm) $\Phi_v$ | Part Number    |
|-------------|-------------|-------------|-------|---------------------------------|---------------------------------|----------------|
| 2200K       | 80          | 82          | R9>0  | 26                              | 30                              | MXA8-PW22-S001 |
|             | 80          | 82          | R9>0  | 28                              | 33                              | MXA8-PW22-0000 |
|             | 80          | 82          | R9>0  | 30                              | 35                              | MXA8-PW22-H001 |
| 2500K       | 80          | 82          | R9>0  | 26                              | 32                              | MXA8-PW25-S001 |
|             | 80          | 82          | R9>0  | 28                              | 34                              | MXA8-PW25-0000 |
|             | 80          | 82          | R9>0  | 30                              | 36                              | MXA8-PW25-H001 |
| 2700K       | 80          | 82          | R9>0  | 30                              | 38.5                            | MXA8-PW27-S001 |
|             | 80          | 82          | R9>0  | 36                              | 44                              | MXA8-PW27-0000 |
|             | 80          | 82          | R9>0  | 38                              | 46                              | MXA8-PW27-H001 |
|             | 85          | 92          | R9>50 | 30                              | 33.5                            | MXA9-PW27-S111 |
|             | 85          | 92          | R9>50 | 32                              | 36                              | MXA9-PW27-0000 |
|             | 90          | 92          | R9>50 | 31                              | 36                              | MXA9-PW27-9000 |
|             | 90          | 92          | R9>50 | 32                              | 37                              | MXA9-PW27-H001 |
| 3000K       | 80          | 82          | R>0   | 30                              | 38.5                            | MXA8-PW30-S001 |
|             | 80          | 82          | R>0   | 34                              | 44                              | MXA8-PW30-0000 |
|             | 80          | 82          | R>0   | 38                              | 46                              | MXA8-PW30-H001 |
|             | 85          | 92          | R>50  | 24                              | 33.5                            | MXA9-PW30-S111 |
|             | 90          | 92          | R>50  | 26                              | 32                              | MXA9-PW30-S001 |
|             | 90          | 92          | R>50  | 31                              | 36                              | MXA9-PW30-0000 |
|             | 90          | 92          | R>50  | 32                              | 37                              | MXA9-PW30-H001 |
| 3500K       | 80          | 82          | R9>0  | 30                              | 40.5                            | MXA8-PW35-S001 |
|             | 80          | 82          | R9>0  | 34                              | 44                              | MXA8-PW35-0000 |
|             | 80          | 82          | R9>0  | 40                              | 46                              | MXA8-PW35-H001 |
|             | 90          | 92          | R>50  | 32                              | 40                              | MXA9-PW35-H001 |
| 4000K       | 70          | 72          | -     | 38                              | 44                              | MXA7-PW40-S001 |
|             | 70          | 72          | -     | 40                              | 49                              | MXA7-PW40-0000 |
|             | 70          | 72          | -     | 42                              | 54                              | MXA7-PW40-H001 |
|             | 80          | 82          | R>0   | 34                              | 43                              | MXA8-PW40-S001 |
|             | 80          | 82          | R>0   | 36                              | 46                              | MXA8-PW40-0000 |
|             | 80          | 82          | R>0   | 42                              | 48                              | MXA8-PW40-H001 |
|             | 85          | 92          | R>50  | 24                              | 32                              | MXA9-PW40-S111 |
|             | 85          | 92          | R>50  | 34                              | 40                              | MXA9-PW40-0000 |
|             | 90          | 92          | R>50  | 32                              | 42                              | MXA9-PW40-H001 |
| 5000K       | 70          | 72          | -     | 38                              | 44                              | MXA7-PW50-S001 |
|             | 70          | 72          | -     | 40                              | 49                              | MXA7-PW50-0000 |
|             | 70          | 72          | -     | 42                              | 54                              | MXA7-PW50-H001 |
|             | 80          | 82          | R>0   | 34                              | 43                              | MXA8-PW50-S001 |
|             | 80          | 82          | R>0   | 36                              | 47                              | MXA8-PW50-0000 |
|             | 80          | 82          | R>0   | 42                              | 50                              | MXA8-PW50-H001 |

Table 1 continued on next page.

Table 1 Continued.

| Nominal CCT | Minimum CRI | Typical CRI | R9  | Min Luminous Flux (lm) $\Phi_v$ | Typ Luminous Flux (lm) $\Phi_v$ | Part Number    |
|-------------|-------------|-------------|-----|---------------------------------|---------------------------------|----------------|
| 5700K       | 70          | 72          | -   | 38                              | 44                              | MXA7-PW57-S001 |
|             | 70          | 72          | -   | 40                              | 49                              | MXA7-PW57-0000 |
|             | 70          | 72          | -   | 42                              | 54                              | MXA7-PW57-H001 |
|             | 80          | 82          | R>0 | 30                              | 42                              | MXA8-PW57-S001 |
|             | 80          | 82          | R>0 | 36                              | 45                              | MXA8-PW57-0000 |
|             | 80          | 82          | R>0 | 42                              | 50                              | MXA8-PW57-H001 |
| 6500K       | 70          | 72          | -   | 38                              | 46                              | MXA7-PW65-S001 |
|             | 70          | 72          | -   | 40                              | 47.5                            | MXA7-PW65-0000 |
|             | 70          | 72          | -   | 42                              | 52                              | MXA7-PW65-H001 |
|             | 80          | 82          | R>0 | 30                              | 42                              | MXA8-PW65-S001 |
|             | 80          | 82          | R>0 | 36                              | 45                              | MXA8-PW65-0000 |
|             | 80          | 82          | R>0 | 42                              | 50                              | MXA8-PW65-H001 |

Note for Table 1:

1. Lumileds maintains a tolerance of  $\pm 7.5\%$  on luminous flux and  $\pm 2$  on CRI measurements.

## Optical Characteristics

### Optical Characteristics of LUXEON 3535L LEDs

Solder Pad Temperature = 25°C, Test Current = 100mA

Table 2.

| Nominal CCT | Color Temperature |         |         | Typ Total Included Angle <sup>(1)</sup><br>(degrees) $\theta_{0.90v}$ | Typ Viewing Angle <sup>(2)</sup><br>(degrees) $2\theta_{1/2}$ |
|-------------|-------------------|---------|---------|---|---|
|             | Minimum           | Typical | Maximum |   |   |
| 2200K       | 2113K             | 2230K   | 2361K   | 140   | 115   |
| 2500K       | 2305K             | 2452K   | 2580K   | 140   | 115   |
| 2700K       | 2580K             | 2700K   | 2850K   | 140   | 115   |
| 3000K       | 2850K             | 3000K   | 3200K   | 140   | 115   |
| 3500K       | 3200K             | 3500K   | 3750K   | 140   | 115   |
| 4000K       | 3750K             | 4000K   | 4250K   | 140   | 115   |
| 5000K       | 4700K             | 5000K   | 5300K   | 140   | 115   |
| 5700K       | 5300K             | 5700K   | 6000K   | 140   | 115   |
| 6500K       | 6000K             | 6500K   | 7000K   | 140   | 115   |

Notes for Table 2:

1. Total angle at which 90% of total luminous flux is captured.
2. Viewing angle is the off axis angle from lamp centerline where the luminous intensity is 1/2 of the peak value.

# Electrical Characteristics

## Electrical Characteristics of LUXEON 3535L LEDs Solder Pad Temperature = 25°C, Test Current = 100mA

Table 3.

| Part Numbers   | Forward Voltage $V_f$ [1] (V) |         |         | Typ. Temperature Coefficient of Forward Voltage [2] (mV/°C)<br>$\Delta V_f / \Delta T_J$ | Typical Thermal Resistance Junction to Solder Pad (°C/W)<br>$R\theta_{J-C}$ |
|----------------|-------------------------------|---------|---------|--|---|
|                | Minimum                       | Typical | Maximum |  |   |
| MXAx-PWxx-H001 | 2.7                           | 2.90    | 3.2     | -2.0 to -4.0   | 18  |
| MXAx-PWxx-S001 | 2.8                           | 3.00    | 3.4     | -2.0 to -4.0   | 22  |
| MXAx-PWxx-0000 | 2.8                           | 3.05    | 3.4     | -2.0 to -4.0   | 18  |

Notes for Table 3:

- Lumileds maintains a tolerance of  $\pm 0.10V$  on forward voltage measurements.
- Measured between  $T_f = 25^\circ C$  and  $T_j = 110^\circ C$ .

## Absolute Maximum Ratings

Table 4.

| Parameter                                | Maximum Performance   |
|--|---|
| DC Forward Current (mA) [1] [3]          | MXAx-PWxx-S001 and MXAx-PWxx-0000: 200<br>MXAx-PWxx-H001: 300 |
| Peak Pulsed Forward Current (mA) [2] [3] | MXAx-PWxx-S001 and MXAx-PWxx-0000: 240<br>MXAx-PWxx-H001: 350 |
| ESD Sensitivity                          | Class 3A Human Body Model<br>Class C Machine Model            |
| LED Junction Temperature [3]             | 125°C   |
| Operating Case Temperature at 100mA      | -40°C - 105°C   |
| Storage Temperature                      | -40°C - 105°C   |
| Soldering Temperature                    | JEDEC 020D 260°C  |
| Allowable Reflow Cycles                  | 3   |
| Reverse Voltage (Vr) [4], [5]            | -5V   |

Notes for Table 4:

- Ripple current with a frequency of 50-150Hz is allowed, as long as the average of the current waveform is below 200mA, and the maximum of the current waveform is lower than 240mA.
- At 10% duty cycle and pulse width 10ms.
- Proper current derating must be observed to maintain junction temperature below the maximum.
- LUXEON 3535L LEDs are not designed to be driven in reverse bias.
- At maximum reverse current of 10 $\mu$ A.

## JEDEC Moisture Sensitivity

Table 5.

| Level | Floor Life |                             | Soak Requirements      |                             |
|-------|------------|-----------------------------|------------------------|-----------------------------|
|       | Time       | Conditions                  | Standard               |                             |
|       |            |                             | Time                   | Conditions                  |
| 2     | 1 year     | $\leq 30^\circ C / 60\% RH$ | 168 Hrs. + 5 / -0 Hrs. | $\leq 85^\circ C / 60\% RH$ |

# Reflow Soldering Characteristics

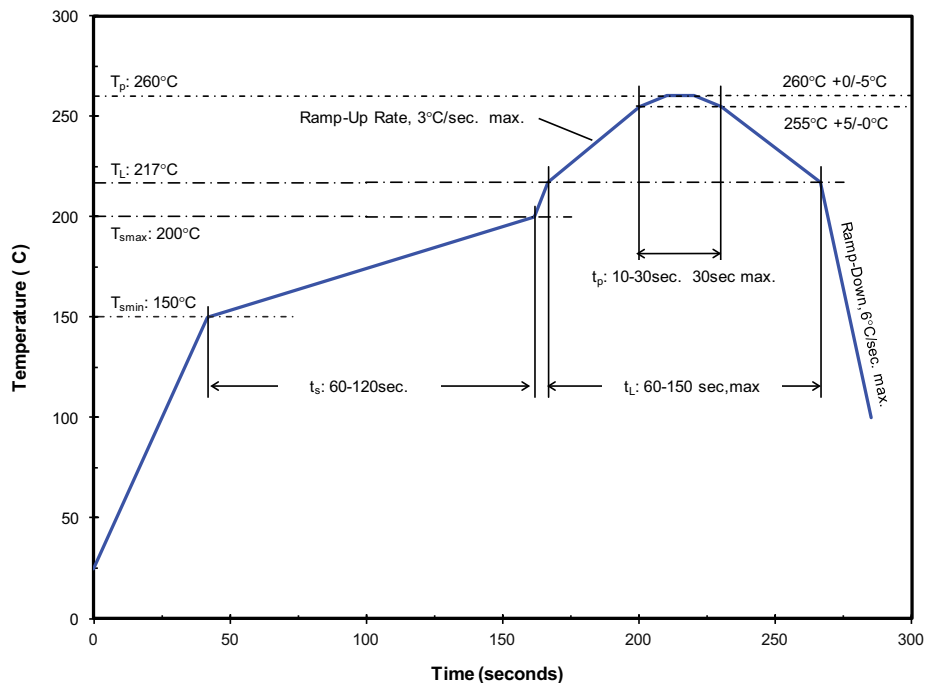

Temperature Profile for Table 6.

Table 6. Reflow Profile in Accordance with J-Std-020D.

| Profile Feature  | Lead Free Assembly |
|--|--------------------|
| Preheat/Soak :   |                    |
| Temperature Min ( $T_{smin}$ )                                   | 150°C              |
| Temperature Max ( $T_{smax}$ )                                   | 200°C              |
| Maximum Time ( $t_s$ ) from $T_{smin}$ to $T_{smax}$             | 120 seconds        |
| Ramp-up Rate ( $T_L$ to $T_p$ )                                  | 3°C / second       |
| Liquidous Temperature ( $T_L$ )                                  | 217°C              |
| Maximum Time ( $t_L$ ) Maintained above $T_L$                    | 150 seconds        |
| Maximum Peak Package Body Temperature ( $T_p$ )                  | 260°C              |
| Time ( $t_p$ ) within 5°C of the specified temperature ( $T_c$ ) | 10-30 seconds      |
| Maximum Ramp-Down Rate ( $T_p$ to $T_L$ )                        | 6°C / second       |
| Maximum Time 25°C to Peak Temperature                            | 8 minutes          |

Note for Table 6:

- All temperatures refer to the application Printed Circuit Board (PCB), measured on the surface adjacent to the package body.

# Mechanical Dimensions

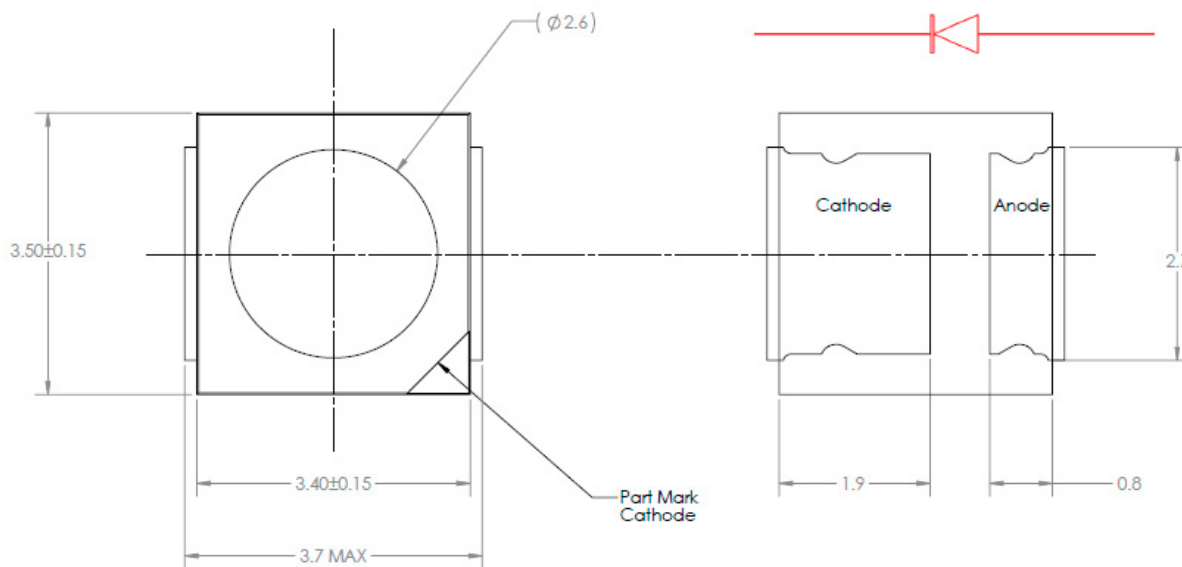

Figure 1. Mechanical dimensions for LUXEON 3535L MXAx-PWxx-S001.

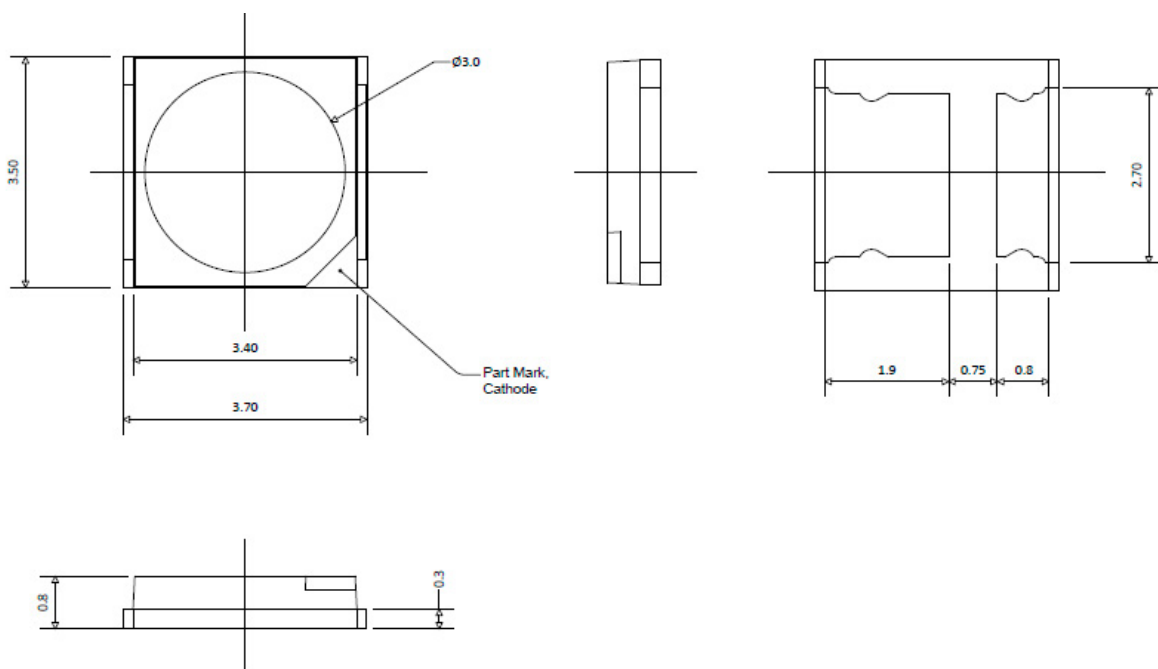

Figure 2. Mechanical dimensions for LUXEON 3535L MXAx-PWxx-0000 and MXAx-PWxx-H001.

## Notes for Figures 1 and 2:

1. All dimensions are in millimeters.
2. Tolerance:  $\pm 0.10$ mm.
3. Materials:
  - Lead Frame: Copper Alloy with Silver Plating
  - Package Body: High Temperature Thermal Plastic
  - Encapsulant: Silicone Resin
  - Solder Lead Finish: Ni-Ag Plating

# Solder Pad Design

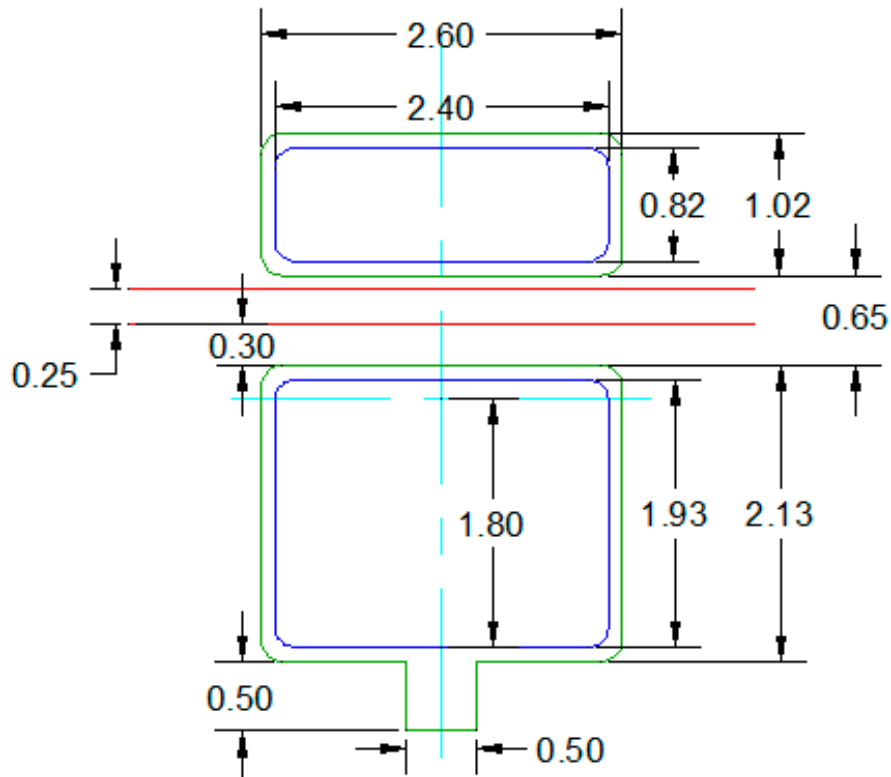

Figure 3. Solder pad layout for LUXEON 3535L.

## Notes for Figure 3:

1. The drawing above shows the recommended solder pad layout on Printed Circuit Board (PCB).
2. Application Brief AB203 provides extensive details for this layout. In addition, the .dwg files are available at [www.lumileds.com](http://www.lumileds.com).

# Assembly Precautions

The LUXEON emitter package contains a silicone overcoat to protect the LED chip and extract the maximum amount of light. As with most silicones used in LED optics, care must be taken to prevent any incompatible chemicals from directly or indirectly reacting with the silicone.

The silicone overcoat used in the LUXEON emitter is gas permeable. Consequently, oxygen and volatile organic compound (VOC) gas molecules can diffuse into the silicone overcoat. VOCs may originate from adhesives, solder fluxes, conformal coating materials, potting materials and even some of the inks that are used to print the PCBs.

Some VOCs and chemicals react with silicone and produce discoloration and surface damage. Other VOCs do not chemically react with the silicone material directly but diffuse into the silicone and oxidize during the presence of heat or light. Regardless of the physical mechanism, both cases may affect the total LED light output. Since silicone permeability increases with temperature, more VOCs may diffuse into and/or evaporate out from the silicone.

Please refer to AB203 for more details on VOCs and other incompatible chemicals.

# Typical Performance Curves

## Spectral Distribution vs. Wavelength Characteristics, MXA7-PWx-xxxx

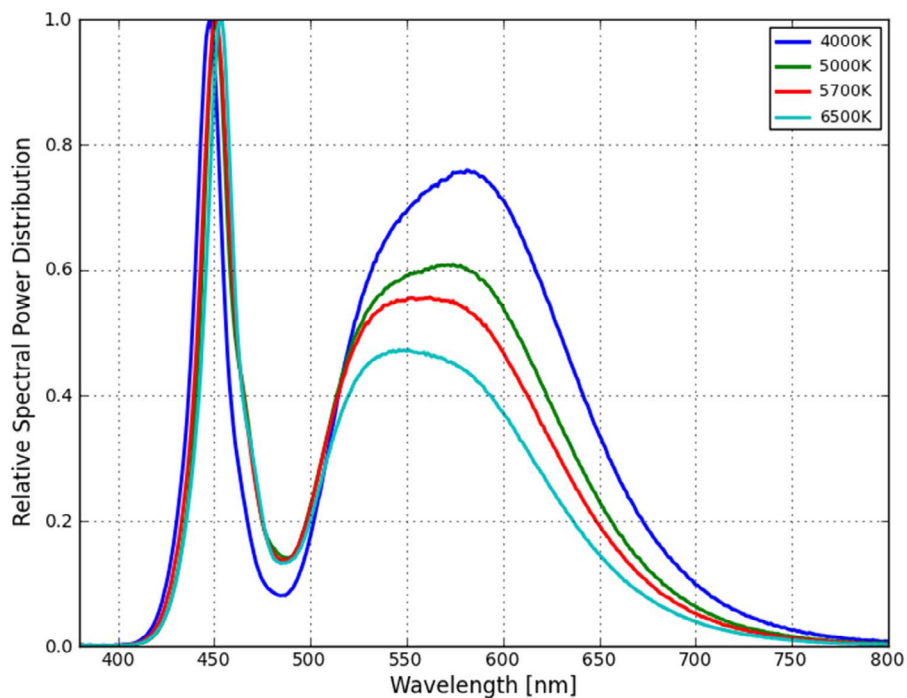

Figure 4a. Typical color spectrum of MXA7-PWx-xxxx emitter, integrated measurement at Test Current = 100mA,  $T_{\text{junction}} = 25^{\circ}\text{C}$ .

## Spectral Distribution vs. Wavelength Characteristics, MXA8-PWx-xxxx

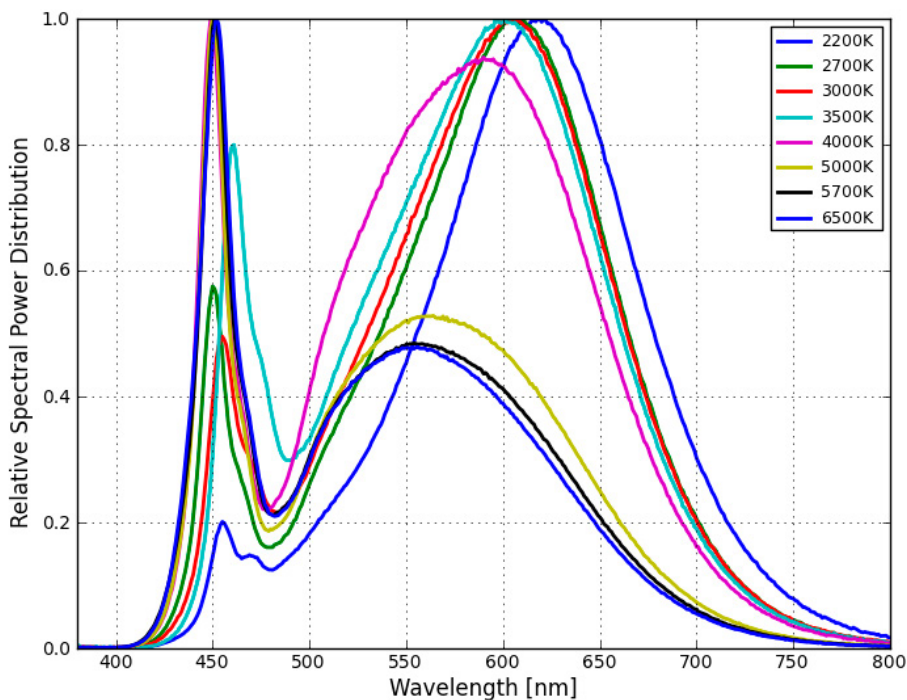

Figure 4b. Typical color spectrum of MXA8-PWx-xxxx emitter, integrated measurement at solder pad temperature =  $25^{\circ}\text{C}$ , forward current = 100mA.

## Spectral Distribution vs. Wavelength Characteristics, MXA9-PWxx-xxxx

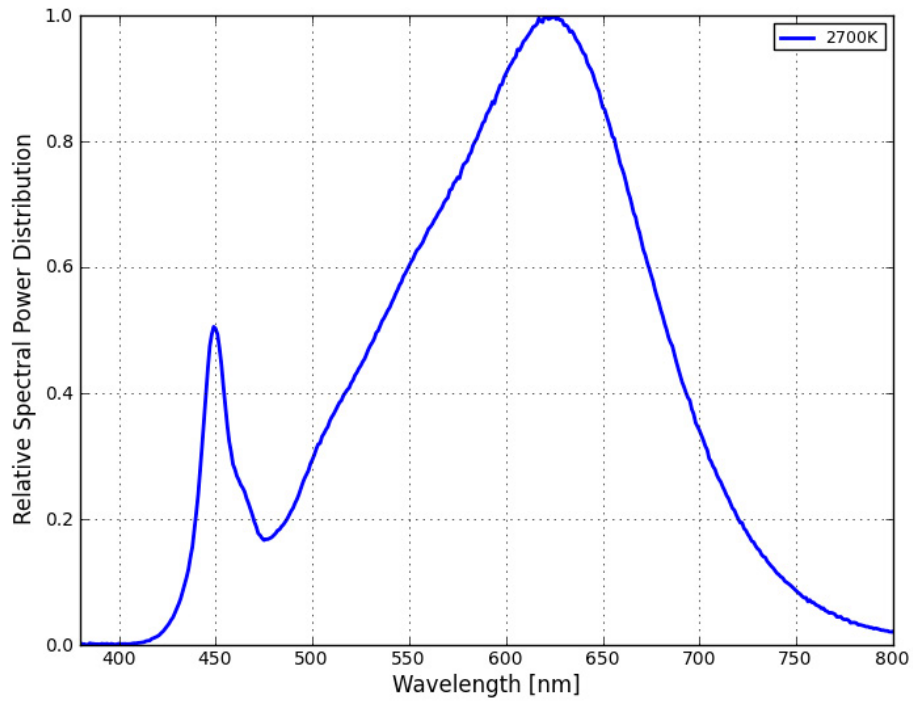

Figure 4c. Typical color spectrum of MXA9-PWxx-xxxx emitter, integrated measurement at solder pad temperature = 25°C, forward current = 100mA.

# Light Output Characteristics

## Relative Luminous Flux vs. Temperature, MXAx-PWxx

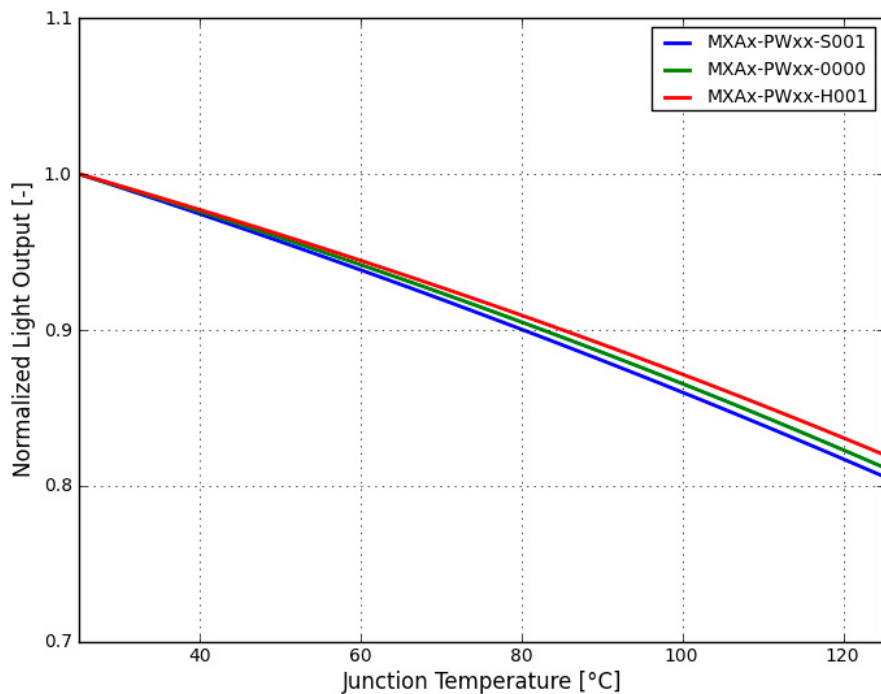

Figure 5. Typical relative light output vs. junction temperature, forward current = 100mA.

## Relative Luminous Flux vs. Forward Current, MXAx-PWxx

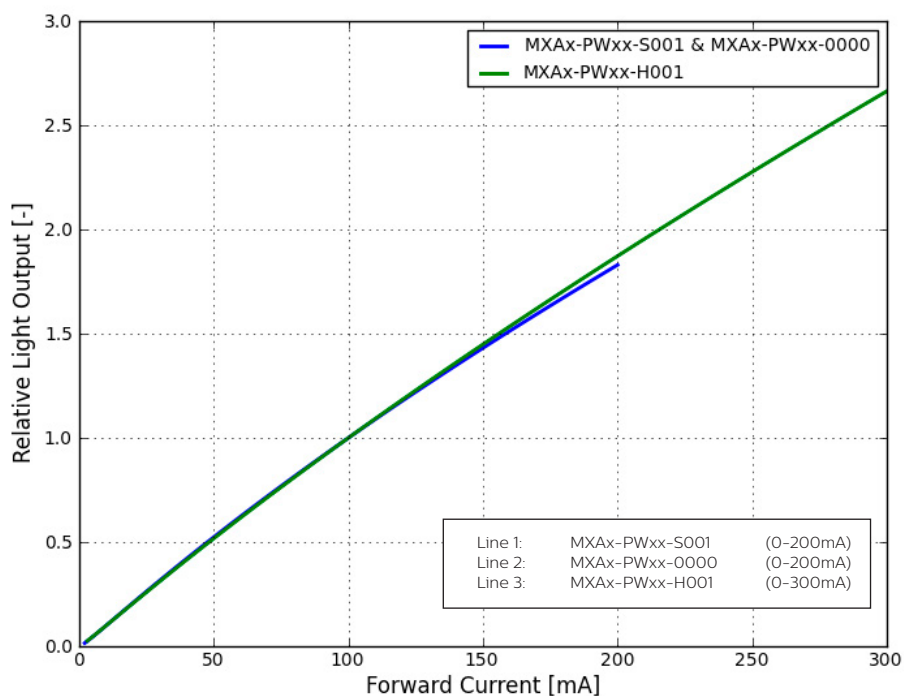

Figure 6. Relative light output vs. forward current, solder pad temperature = 25°C.

# Luminous Efficacy Characteristics

## Relative Luminous Efficacy vs. Temperature. MXAx-PWxx

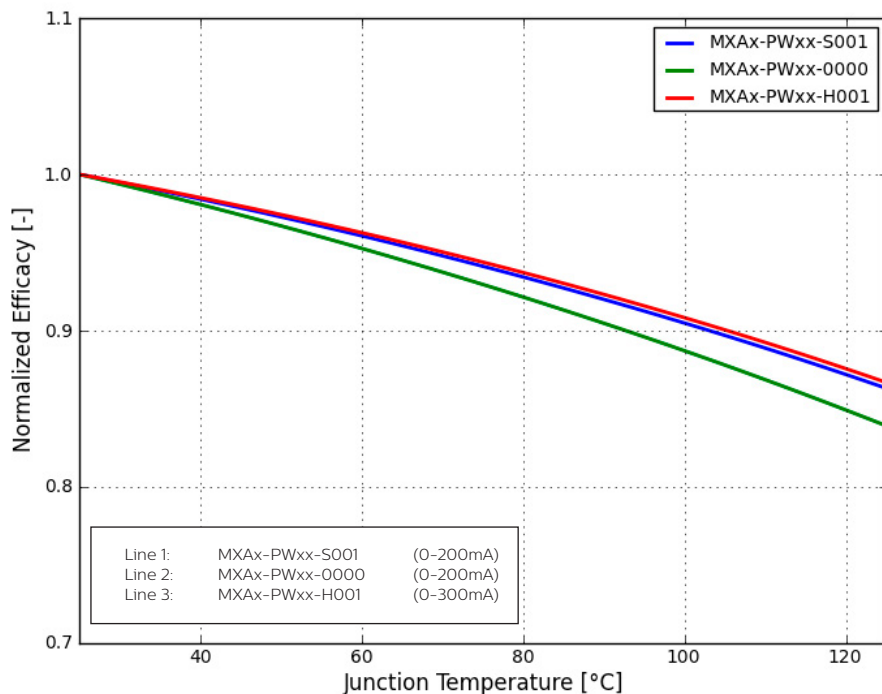

Figure 7. Typical relative emitter efficacy as a function of solder pad temperature. solder pad temperature = 25°C.

# Forward Current Characteristics

## Forward Current vs. Forward Voltage, MXAx-PWxx

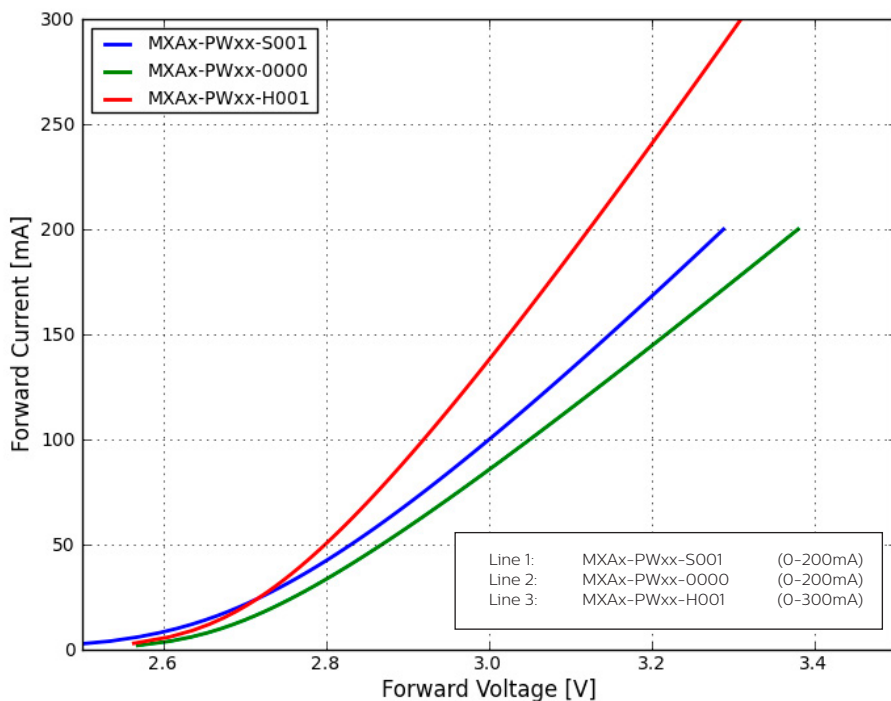

Figure 8. Typical forward current vs. forward voltage. solder pad temperature = 25°C.

# Typical Radiation Patterns

## Radiation Pattern in Cartesian Coordinate System

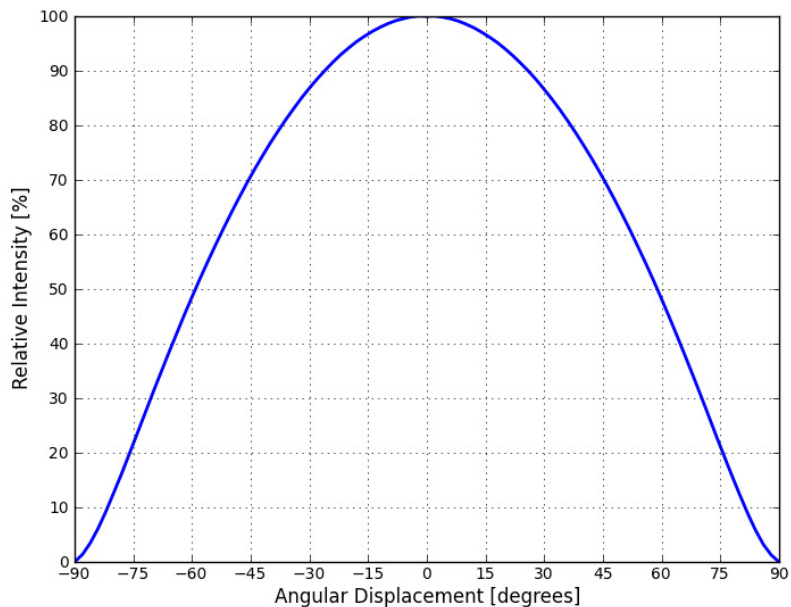

Figure 9. Typical representative spatial radiation pattern.

## Radiation Pattern in Polar Coordinate System

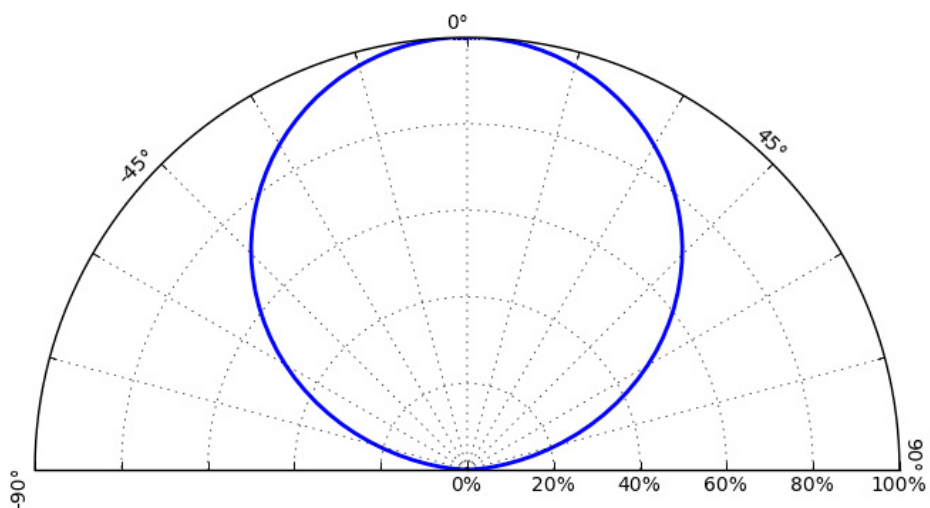

Figure 10. Typical polar plot of radiation pattern.

# Emitter Pocket Tape Packaging

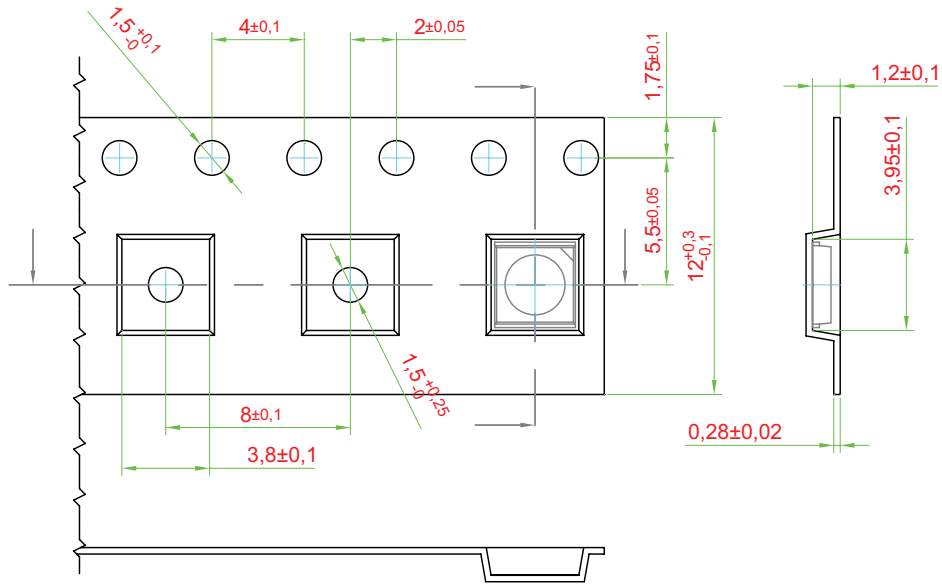

Figure 11. Emitter pocket tape packaging.

## Notes for Figure 11:

1. All dimensions are in millimeters
2. Empty component pockets sealed with top cover tape
3. The maximum number of consecutive missing LEDs is two.

# Emitter Reel Packaging

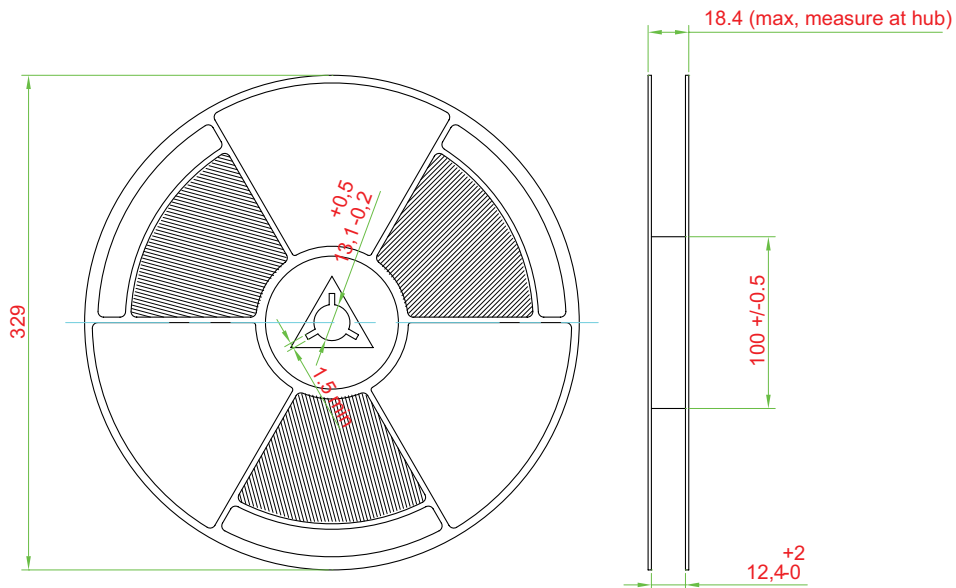

Figure 12. Emitter reel packaging.

## Notes for Figure 12:

1. All dimensions are in millimeters.
2. Empty component pockets sealed with top cover tape.
3. 329mm reel - 5000 pieces per reel.
4. Minimum packing quantity is 5000 pieces.
5. The maximum number of consecutive missing LEDs is two.
6. In accordance with EIA-481-1-B specification.

# Product Binning and Labeling

## Purpose of Product Binning

In the manufacturing of semiconductor products, there is a variation of performance around the average values given in the technical data sheets. For this reason, Lumileds bins the LED components for luminous flux, color and forward voltage ( $V_f$ ).

## Decoding Product Bin Labeling

LUXEON 3535L LEDs are labeled using a four digit alphanumeric code (CAT code) depicting the bin values for emitters packaged on a single reel. All emitters packaged within a reel are of the same 3-variable bin combination. Using these codes, it is possible to determine optimum mixing and matching of products for consistency in a given application.

Reels of 2700K, 3000K, 3500K, 4000K, 5000K, 5700K, 6500K emitters are labeled with a four digit alphanumeric CAT code following the format below.

A B C D or A x B C D

Where:

A = Flux bin (L etc.)

x = PLL internal use

B and C = Color bin (For example 51, 52, 53, 54, 55, 56)

D =  $V_f$  bin

## Luminous Flux Bins

Table 7 and Table 8 list the standard photometric luminous flux bins for LUXEON 3535L LEDs (tested and binned at 100mA). Although several bins are outlined, product availability in a particular bin varies by production run and by product performance. Not all bins are available in all colors. Please contact your Lumileds representative for the MXA9-PW27 flux bins.

**Table 7. Flux Bins**

| Bin Code | Minimum Photometric Flux (lm) | Maximum Photometric Flux (lm) |
|----------|-------------------------------|-------------------------------|
| J        | 24                            | 28                            |
| K        | 28                            | 32                            |
| L        | 32                            | 36                            |
| M        | 36                            | 40                            |
| P        | 40                            | 44                            |
| Q        | 44                            | 48                            |
| R        | 48                            | 52                            |
| S        | 52                            | 56                            |

Tested and binned at 25°C,  $I_f=100\text{mA}$ . Tester tolerance:  $\pm 7.5\%$ .

## Forward Voltage Bins

Table 8.  $V_f$  Bins

| Bin Code | Minimum Forward Voltage (V) | Maximum Forward Voltage (V) |
|----------|-----------------------------|-----------------------------|
| T        | 2.8                         | 2.9                         |
| V        | 2.9                         | 3.0                         |
| W        | 3.0                         | 3.1                         |
| X        | 3.1                         | 3.2                         |
| Y        | 3.2                         | 3.3                         |

Tested and binned at 25°C,  $I_f = 100\text{mA}$ . Tester tolerance:  $\pm 0.1\text{V}$ .

# Color Bin Structure

## MXAx-PW22-xxxx Color Bin Structure

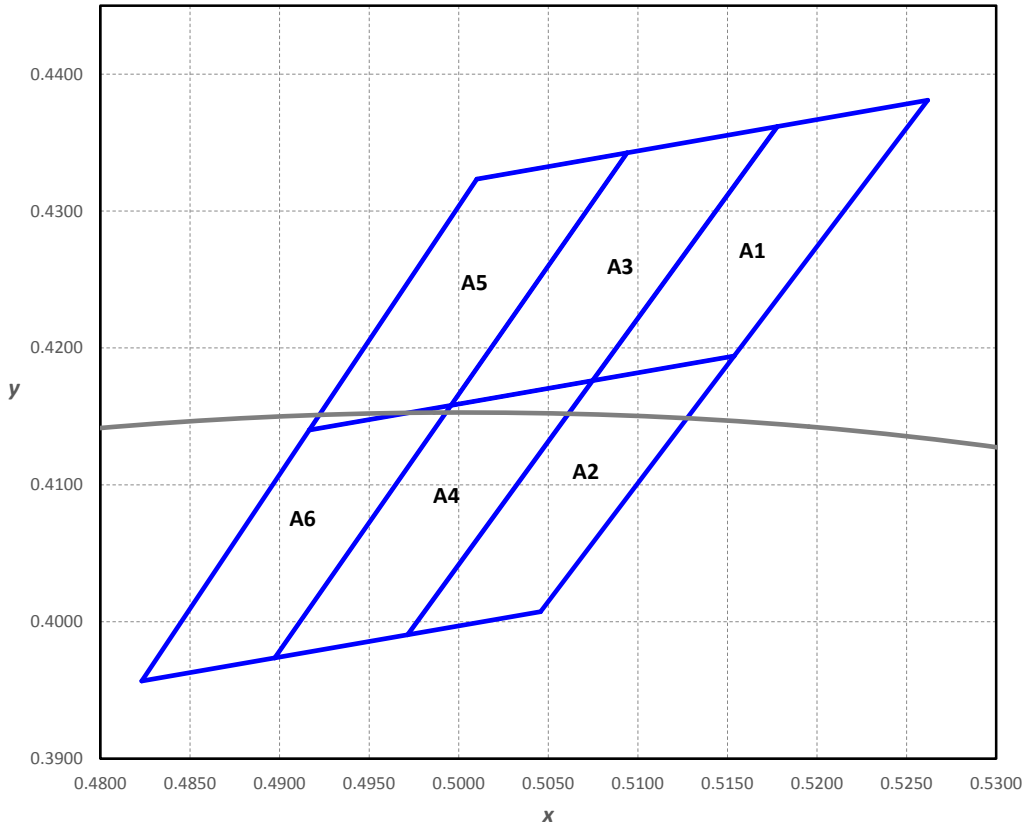

Figure 13. 2200K 1/6<sup>th</sup> color bin structure.

LUXEON 3535L LEDs are tested and binned by x,y coordinates.

Table 9.

| LUXEON 3535L ANSI 1/6 <sup>th</sup> Color Bin Coordinates for MxAx-PW22-xxxx |        |        |          |        |        |          |        |        |
|--|--------|--------|----------|--------|--------|----------|--------|--------|
| Bin Code   | x      | y      | Bin Code | x      | y      | Bin Code | x      | y      |
| A5   | 0.5010 | 0.4323 | A3       | 0.5094 | 0.4343 | A1       | 0.5178 | 0.4362 |
|  | 0.5094 | 0.4343 |          | 0.5178 | 0.4362 |          | 0.5262 | 0.4381 |
|  | 0.4996 | 0.4158 |          | 0.5075 | 0.4176 |          | 0.5154 | 0.4194 |
|  | 0.4917 | 0.4140 |          | 0.4996 | 0.4158 |          | 0.5075 | 0.4176 |
| A6   | 0.4917 | 0.4140 | A4       | 0.4996 | 0.4158 | A2       | 0.5075 | 0.4176 |
|  | 0.4996 | 0.4158 |          | 0.5075 | 0.4176 |          | 0.5154 | 0.4194 |
|  | 0.4897 | 0.3974 |          | 0.4972 | 0.3990 |          | 0.5046 | 0.4007 |
|  | 0.4823 | 0.3957 |          | 0.4897 | 0.3974 |          | 0.4972 | 0.3990 |

Notes for Table 9:

1. Tested and binned at 25°C and  $I_f = 100\text{mA}$ . Tester tolerance:  $\pm 0.007$  in x and y coordinates.

# Color Bin Structure, Continued

## MXAx-PW25-xxxx Color Bin Structure

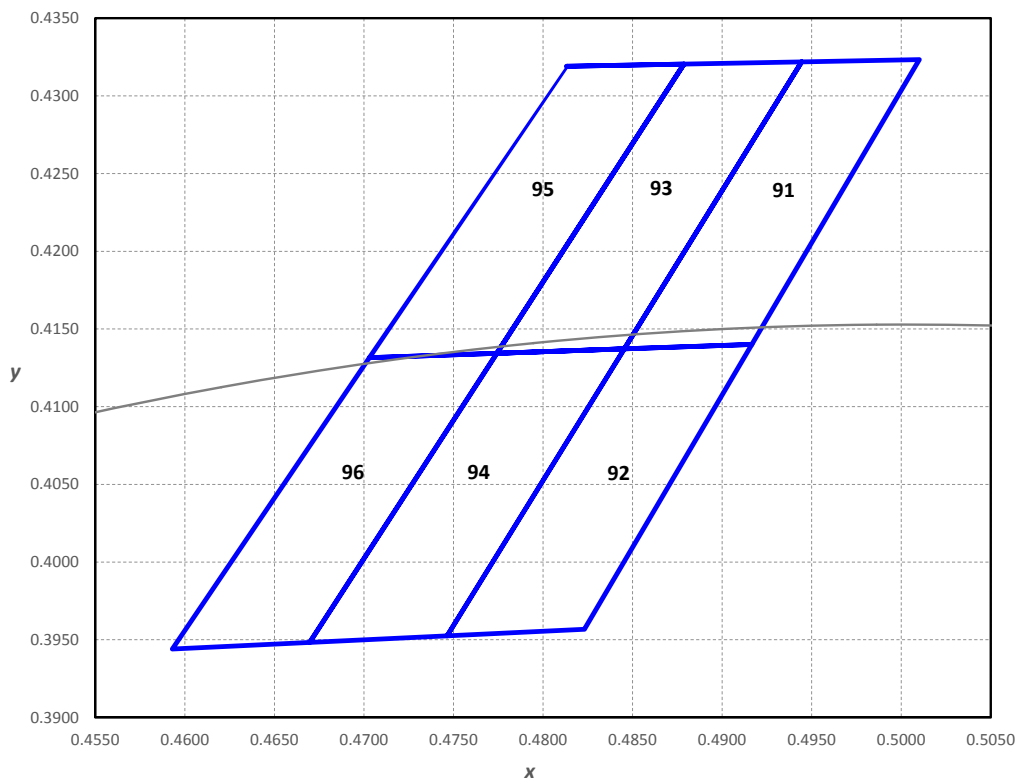

Figure 14. 2500K 1/6<sup>th</sup> ANSI color bin structure.

LUXEON 3535L LEDs are tested and binned by x,y coordinates.

Table 10.

| LUXEON 3535L ANSI 1/6 <sup>th</sup> Color Bin Coordinates for MXAx-PW25-xxxx |        |        |          |        |        |          |        |        |
|--|--------|--------|----------|--------|--------|----------|--------|--------|
| Bin Code   | x      | y      | Bin Code | x      | y      | Bin Code | x      | y      |
| 95   | 0.4813 | 0.4319 | 93       | 0.4879 | 0.4320 | 91       | 0.4944 | 0.4322 |
|  | 0.4879 | 0.4320 |          | 0.4944 | 0.4322 |          | 0.5010 | 0.4323 |
|  | 0.4774 | 0.4134 |          | 0.4845 | 0.4137 |          | 0.4917 | 0.4140 |
|  | 0.4703 | 0.4132 |          | 0.4774 | 0.4134 |          | 0.4845 | 0.4137 |
| 96   | 0.4703 | 0.4132 | 94       | 0.4774 | 0.4134 | 92       | 0.4845 | 0.4137 |
|  | 0.4774 | 0.4134 |          | 0.4845 | 0.4137 |          | 0.4917 | 0.4140 |
|  | 0.4670 | 0.3948 |          | 0.4746 | 0.3952 |          | 0.4823 | 0.3957 |
|  | 0.4593 | 0.3944 |          | 0.4670 | 0.3948 |          | 0.4746 | 0.3952 |

Notes for Table 10:

1. Tested and binned at 25°C and I<sub>f</sub> = 100mA. Tester tolerance: ±0.007 in x and y coordinates.

# Color Bin Structure, Continued

## MXAx-PW27-xxxx Color Bin Structure

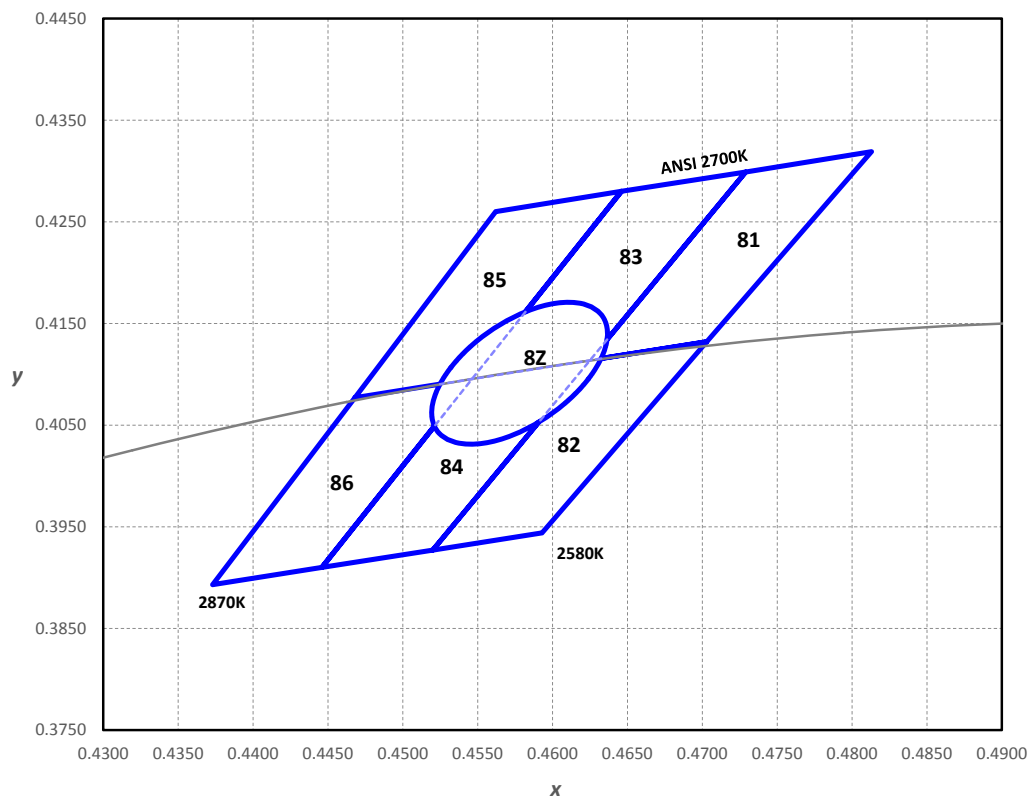

Figure 15. ANSI 2700K 1/7<sup>th</sup> color bin structure.

LUXEON 3535L LEDs are tested and binned by x,y coordinates.

Table 11.

| LUXEON 3535L ANSI 1/7 <sup>th</sup> Color Bin Coordinates for MXAx-PW27-xxxx Emitter |                     |        |            |            |                        |
|--|---------------------|--------|------------|------------|------------------------|
| Bin Code   | x                   | y      | Bin Code   | x          | y                      |
| 81   | 0.4625              | 0.4113 | 84         | 0.4446     | 0.3910                 |
|  | 0.4729              | 0.4299 |            | 0.4546     | 0.4095                 |
|  | 0.4813              | 0.4319 |            | 0.4625     | 0.4113                 |
|  | 0.4703              | 0.4132 |            | 0.4520     | 0.3927                 |
| 82   | 0.4520              | 0.3927 | 85         | 0.4468     | 0.4077                 |
|  | 0.4625              | 0.4113 |            | 0.4562     | 0.4260                 |
|  | 0.4703              | 0.4132 |            | 0.4646     | 0.4280                 |
|  | 0.4593              | 0.3944 |            | 0.4546     | 0.4095                 |
| 83   | 0.4546              | 0.4095 | 86         | 0.4373     | 0.3893                 |
|  | 0.4646              | 0.4280 |            | 0.4468     | 0.4077                 |
|  | 0.4729              | 0.4299 |            | 0.4546     | 0.4095                 |
|  | 0.4625              | 0.4113 |            | 0.4446     | 0.3910                 |
| Color Space  | Target Center Point |        | Major Axis | Minor Axis | Ellipse Rotation Angle |
|  | cx                  | cy     |            |            |                        |
| 8Z   | 0.4578              | 0.4101 | 0.00810    | 0.00420    | 53.70                  |

Notes for Table 11:

1. Tested and binned at 25°C and I<sub>f</sub> = 100mA. Tester tolerance: ±0.007 in x and y coordinates.

# Color Bin Structure, Continued

## MXA8-PW30-xxxx Color Bin Structure

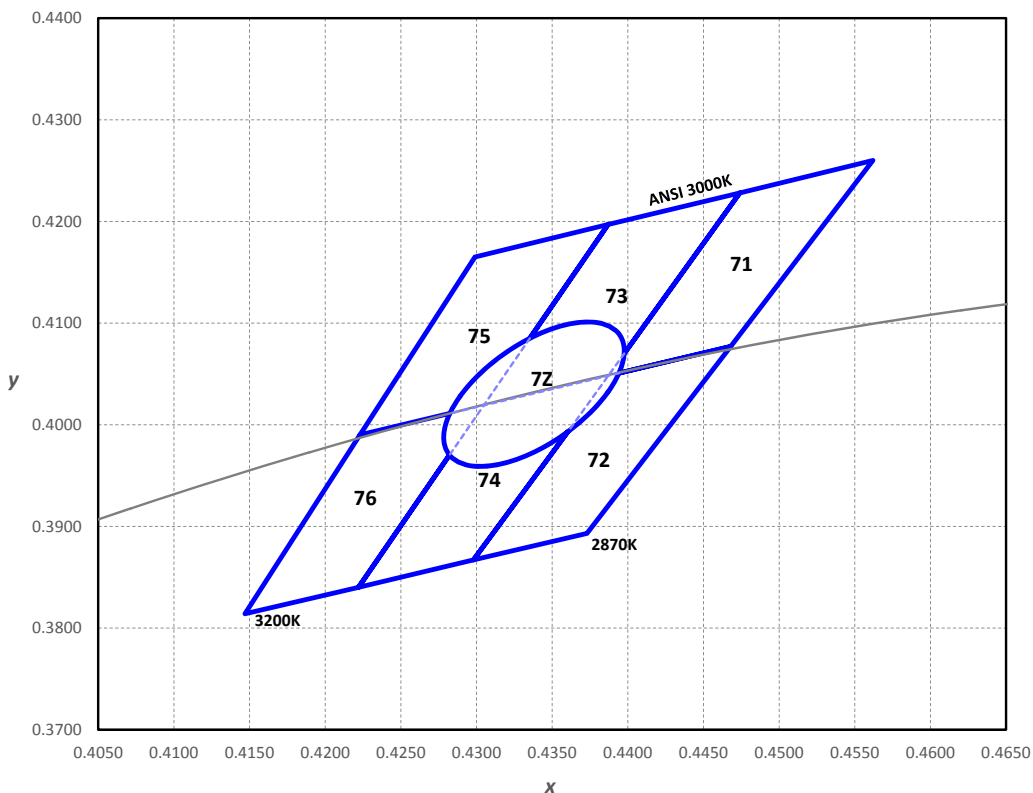

Figure 16. ANSI 3000K 1/7<sup>th</sup> color bin structure.

LUXEON 3535L LEDs are tested and binned by x,y coordinates.

Table 12.

| LUXEON 3535L ANSI 1/7 <sup>th</sup> Color Bin Coordinates for MXA8-PW30-xxxx Emitter |                     |        |            |            |                        |
|--|---------------------|--------|------------|------------|------------------------|
| Bin Code   | x                   | y      | Bin Code   | x          | y                      |
| 71   | 0.4386              | 0.4048 | 74         | 0.4222     | 0.3840                 |
|  | 0.4474              | 0.4228 |            | 0.4305     | 0.4019                 |
|  | 0.4562              | 0.4260 |            | 0.4386     | 0.4048                 |
|  | 0.4468              | 0.4077 |            | 0.4298     | 0.3867                 |
| 72   | 0.4298              | 0.3867 | 75         | 0.4223     | 0.3990                 |
|  | 0.4386              | 0.4048 |            | 0.4299     | 0.4165                 |
|  | 0.4468              | 0.4077 |            | 0.4387     | 0.4197                 |
|  | 0.4373              | 0.3893 |            | 0.4305     | 0.4019                 |
| 73   | 0.4305              | 0.4019 | 76         | 0.4147     | 0.3814                 |
|  | 0.4387              | 0.4197 |            | 0.4223     | 0.3990                 |
|  | 0.4474              | 0.4228 |            | 0.4305     | 0.4019                 |
|  | 0.4386              | 0.4048 |            | 0.4222     | 0.3840                 |
| Color Space  | Target Center Point |        | Major Axis | Minor Axis | Ellipse Rotation Angle |
|  | cx                  | cy     |            |            |                        |
| 7Z   | 0.4338              | 0.403  | 0.00834    | 0.00408    | 53.22                  |

Notes for Table 12:

1. Tested and binned at 25°C and I<sub>f</sub> = 100mA. Tester tolerance: ±0.007 in x and y coordinates.

# Color Bin Structure, Continued

## MXA8-PW35-xxxx Color Bin Structure

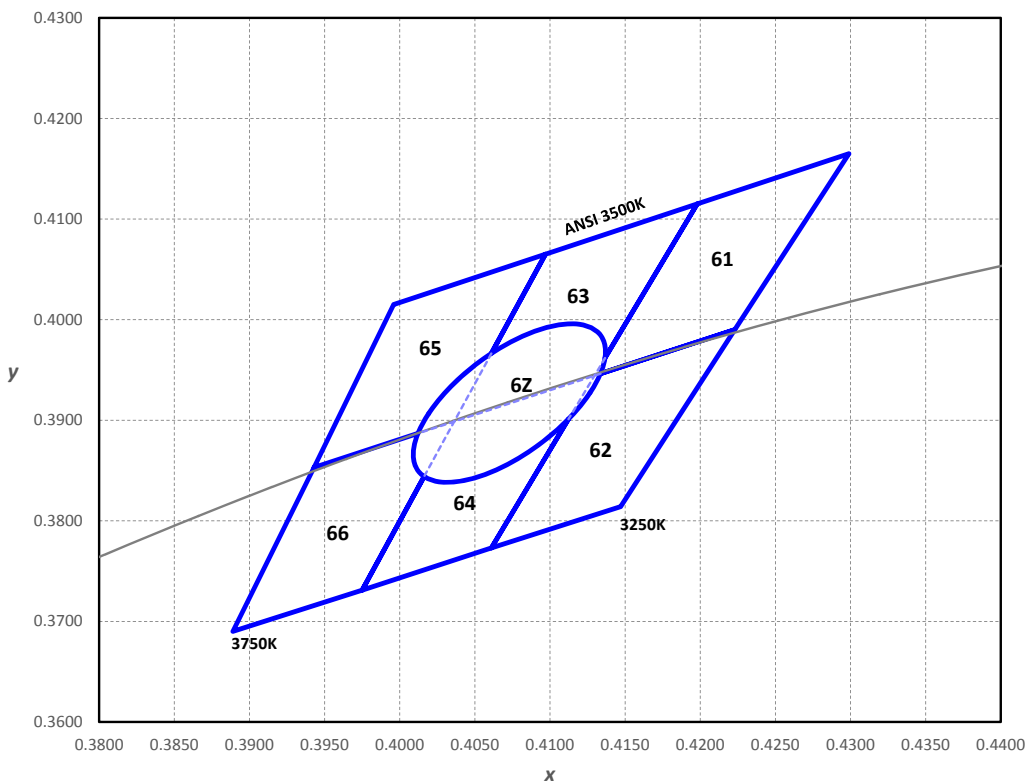

Figure 17. ANSI 3500K 1/7<sup>th</sup> color bin structure.

LUXEON 3535L LEDs are tested and binned by x,y coordinates.

Table 13.

| LUXEON 3535L ANSI 1/7 <sup>th</sup> Color Bin Coordinates for MXA8-PW35-xxxx Emitter |                     |        |            |            |                        |
|--|---------------------|--------|------------|------------|------------------------|
| Bin Code   | x                   | y      | Bin Code   | x          | y                      |
| 61   | 0.4130              | 0.3944 | 64         | 0.3975     | 0.3731                 |
|  | 0.4198              | 0.4115 |            | 0.4036     | 0.3898                 |
|  | 0.4299              | 0.4165 |            | 0.4130     | 0.3944                 |
|  | 0.4223              | 0.3990 |            | 0.4061     | 0.3773                 |
| 62   | 0.4061              | 0.3773 | 65         | 0.3943     | 0.3853                 |
|  | 0.4130              | 0.3944 |            | 0.3996     | 0.4015                 |
|  | 0.4223              | 0.3990 |            | 0.4097     | 0.4065                 |
|  | 0.4147              | 0.3814 |            | 0.4036     | 0.3898                 |
| 63   | 0.4036              | 0.3898 | 66         | 0.3889     | 0.3690                 |
|  | 0.4097              | 0.4065 |            | 0.3943     | 0.3853                 |
|  | 0.4198              | 0.4115 |            | 0.4036     | 0.3898                 |
|  | 0.4130              | 0.3944 |            | 0.3975     | 0.3731                 |
| Color Space  | Target Center Point |        | Major Axis | Minor Axis | Ellipse Rotation Angle |
|  | cx                  | cy     |            |            |                        |
| 6Z   | 0.4073              | 0.3917 | 0.00927    | 0.00414    | 54.00                  |

Notes for Table 13:

1. Tested and binned at 25°C and I<sub>f</sub> = 100mA. Tester tolerance: ±0.007 in x and y coordinates.

# Color Bin Structure, Continued

## MXAx-PW40-xxxx Color Bin Structure

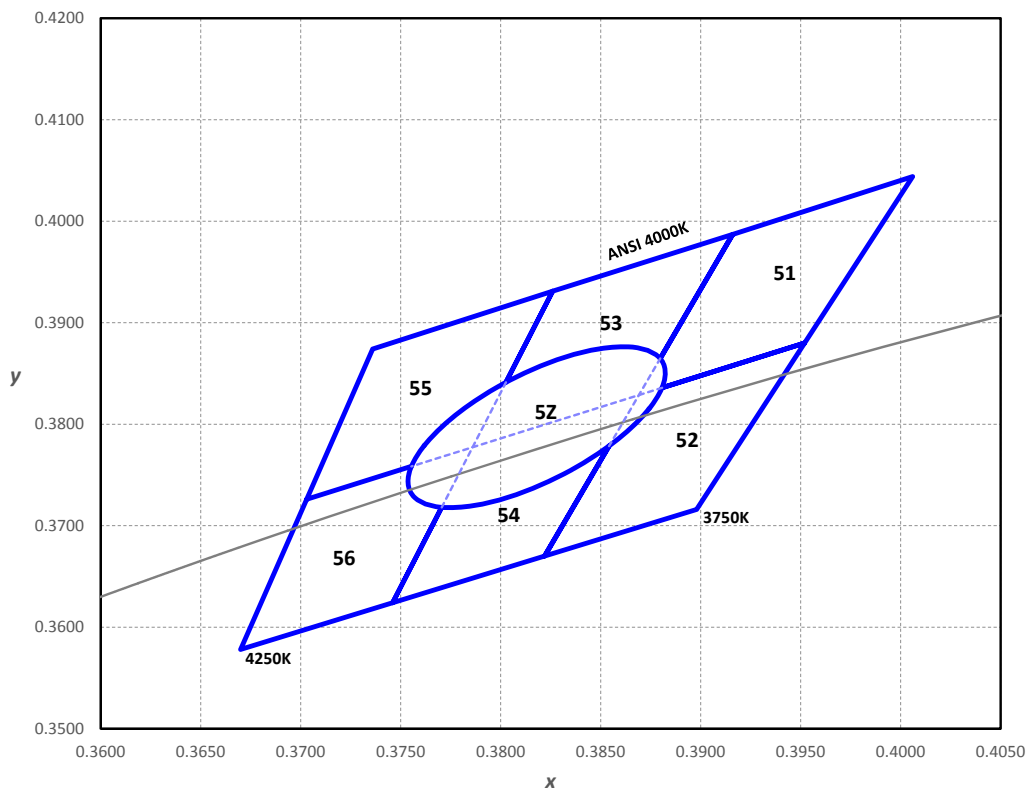

Figure 18. ANSI 4000K 1/7<sup>th</sup> color bin structure.

LUXEON 3535L LEDs are tested and binned by x,y coordinates.

Table 14.

| LUXEON 3535L ANSI 1/7 <sup>th</sup> Color Bin Coordinates for MxAx-PW40-xxxx Emitter |                     |        |            |            |                        |
|--|---------------------|--------|------------|------------|------------------------|
| Bin Code   | x                   | y      | Bin Code   | x          | y                      |
| 51   | 0.3869              | 0.3829 | 54         | 0.3746     | 0.3624                 |
|  | 0.3916              | 0.3987 |            | 0.3786     | 0.3777                 |
|  | 0.4006              | 0.4044 |            | 0.3869     | 0.3829                 |
|  | 0.3952              | 0.3880 |            | 0.3822     | 0.3670                 |
| 52   | 0.3822              | 0.3670 | 55         | 0.3703     | 0.3726                 |
|  | 0.3869              | 0.3829 |            | 0.3736     | 0.3874                 |
|  | 0.3952              | 0.3880 |            | 0.3826     | 0.3931                 |
|  | 0.3898              | 0.3716 |            | 0.3786     | 0.3777                 |
| 53   | 0.3786              | 0.3777 | 56         | 0.3670     | 0.3578                 |
|  | 0.3826              | 0.3931 |            | 0.3703     | 0.3726                 |
|  | 0.3916              | 0.3987 |            | 0.3786     | 0.3777                 |
|  | 0.3869              | 0.3829 |            | 0.3746     | 0.3624                 |
| Color Space  | Target Center Point |        | Major Axis | Minor Axis | Ellipse Rotation Angle |
|  | cx                  | cy     |            |            |                        |
| 5Z   | 0.3818              | 0.3797 | 0.00939    | 0.00402    | 53.72                  |

Notes for Table 14:

1. Tested and binned at 25°C and I<sub>f</sub> = 100mA. Tester tolerance: ±0.007 in x and y coordinates.

# Color Bin Structure, Continued

## MXA8-PW50-xxxx Color Bin Structure

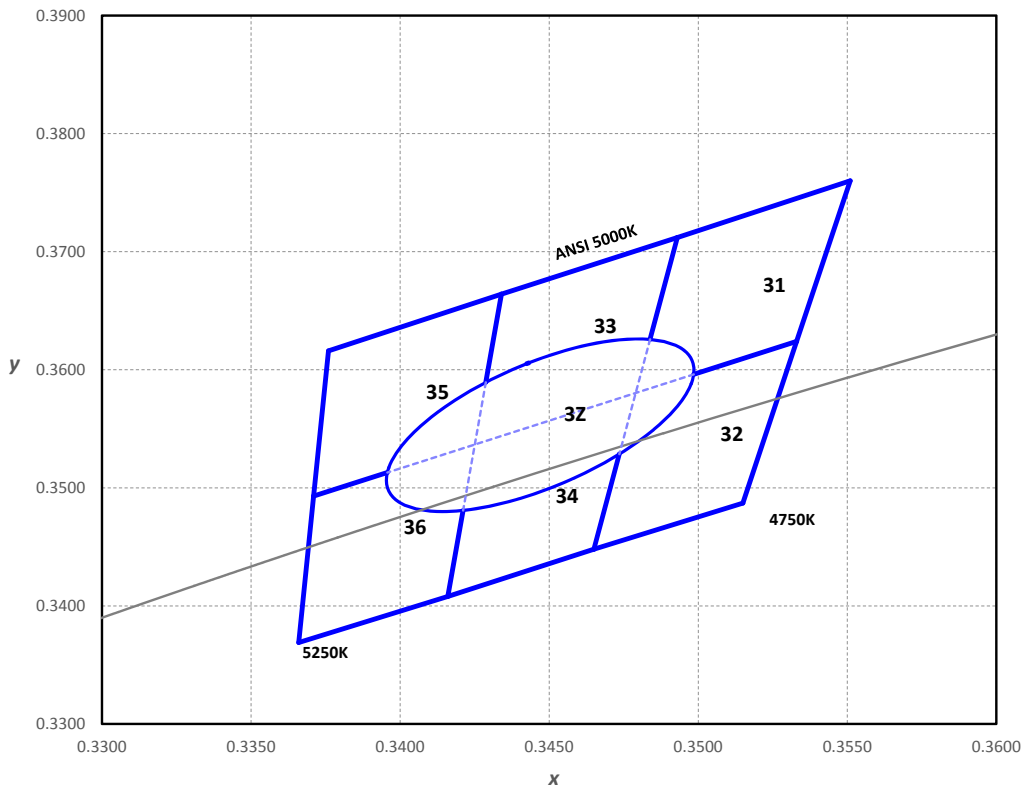

Figure 19. ANSI 5000K 1/7<sup>th</sup> color bin structure.

LUXEON 3535L LEDs are tested and binned by x,y coordinates.

Table 15.

| LUXEON 3535L ANSI 1/7 <sup>th</sup> Color Bin Coordinates for MXA8-PW50-xxxx Emitter |                     |        |            |            |                        |
|--|---------------------|--------|------------|------------|------------------------|
| Bin Code   | x                   | y      | Bin Code   | x          | y                      |
| 31   | 0.3479              | 0.3580 | 34         | 0.3416     | 0.3408                 |
|  | 0.3493              | 0.3712 |            | 0.3425     | 0.3536                 |
|  | 0.3551              | 0.3760 |            | 0.3479     | 0.3580                 |
|  | 0.3533              | 0.3624 |            | 0.3465     | 0.3448                 |
| 32   | 0.3465              | 0.3448 | 35         | 0.3371     | 0.3493                 |
|  | 0.3479              | 0.3580 |            | 0.3376     | 0.3616                 |
|  | 0.3533              | 0.3624 |            | 0.3434     | 0.3664                 |
|  | 0.3515              | 0.3487 |            | 0.3425     | 0.3536                 |
| 33   | 0.3425              | 0.3536 | 36         | 0.3366     | 0.3369                 |
|  | 0.3434              | 0.3664 |            | 0.3371     | 0.3493                 |
|  | 0.3493              | 0.3712 |            | 0.3425     | 0.3536                 |
|  | 0.3479              | 0.3580 |            | 0.3416     | 0.3408                 |
| Color Space  | Target Center Point |        | Major Axis | Minor Axis | Ellipse Rotation Angle |
|  | cx                  | cy     |            |            |                        |
| 3Z   | 0.3447              | 0.3553 | 0.00822    | 0.00354    | 59.62                  |

Notes for Table 15:

1. Tested and binned at 25°C and I<sub>f</sub> = 100mA. Tester tolerance: ±0.007 in x and y coordinates.

# Color Bin Structure, Continued

## MXA8-PW57-xxxx Color Bin Structure

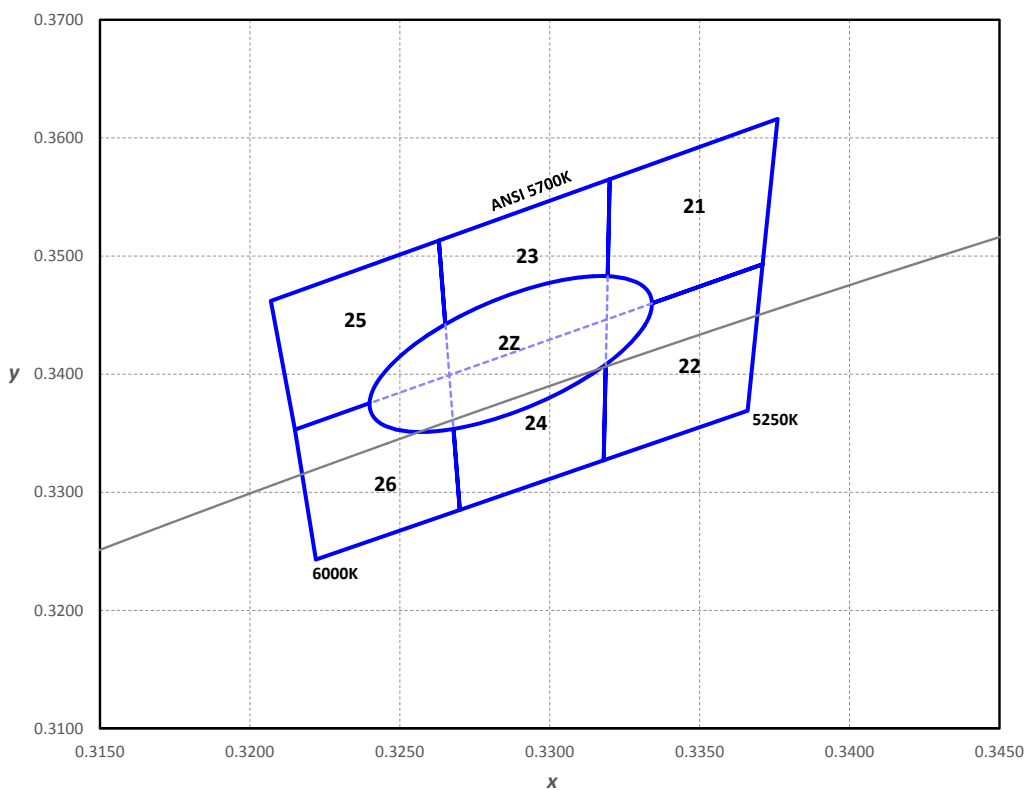

Figure 20. ANSI 5700K 1/7<sup>th</sup> color bin structure.

LUXEON 3535L LEDs are tested and binned by x,y coordinates.

Table 16.

| LUXEON 3535L ANSI 1/7 <sup>th</sup> Color Bin Coordinates for MXA8-PW57-xxxx Emitter |                     |        |            |            |                        |
|--|---------------------|--------|------------|------------|------------------------|
| Bin Code   | x                   | y      | Bin Code   | x          | y                      |
| 21   | 0.3319              | 0.3446 | 24         | 0.3270     | 0.3285                 |
|  | 0.3320              | 0.3565 |            | 0.3267     | 0.3399                 |
|  | 0.3376              | 0.3616 |            | 0.3319     | 0.3446                 |
|  | 0.3371              | 0.3493 |            | 0.3318     | 0.3327                 |
| 22   | 0.3318              | 0.3327 | 25         | 0.3215     | 0.3353                 |
|  | 0.3319              | 0.3446 |            | 0.3207     | 0.3462                 |
|  | 0.3371              | 0.3493 |            | 0.3263     | 0.3513                 |
|  | 0.3366              | 0.3369 |            | 0.3267     | 0.3399                 |
| 23   | 0.3267              | 0.3399 | 26         | 0.3222     | 0.3243                 |
|  | 0.3263              | 0.3513 |            | 0.3215     | 0.3353                 |
|  | 0.3320              | 0.3565 |            | 0.3267     | 0.3399                 |
|  | 0.3319              | 0.3446 |            | 0.3270     | 0.3285                 |
| Color Space  | Target Center Point |        | Major Axis | Minor Axis | Ellipse Rotation Angle |
|  | cx                  | cy     |            |            |                        |
| 2Z   | 0.3287              | 0.3417 | 0.00746    | 0.00320    | 59.09                  |

Notes for Table 16:

1. Tested and binned at 25°C and I<sub>f</sub> = 100mA. Tester tolerance: ±0.007 in x and y coordinates.

# Color Bin Structure, Continued

## MXA8-PW65-xxxx Color Bin Structure

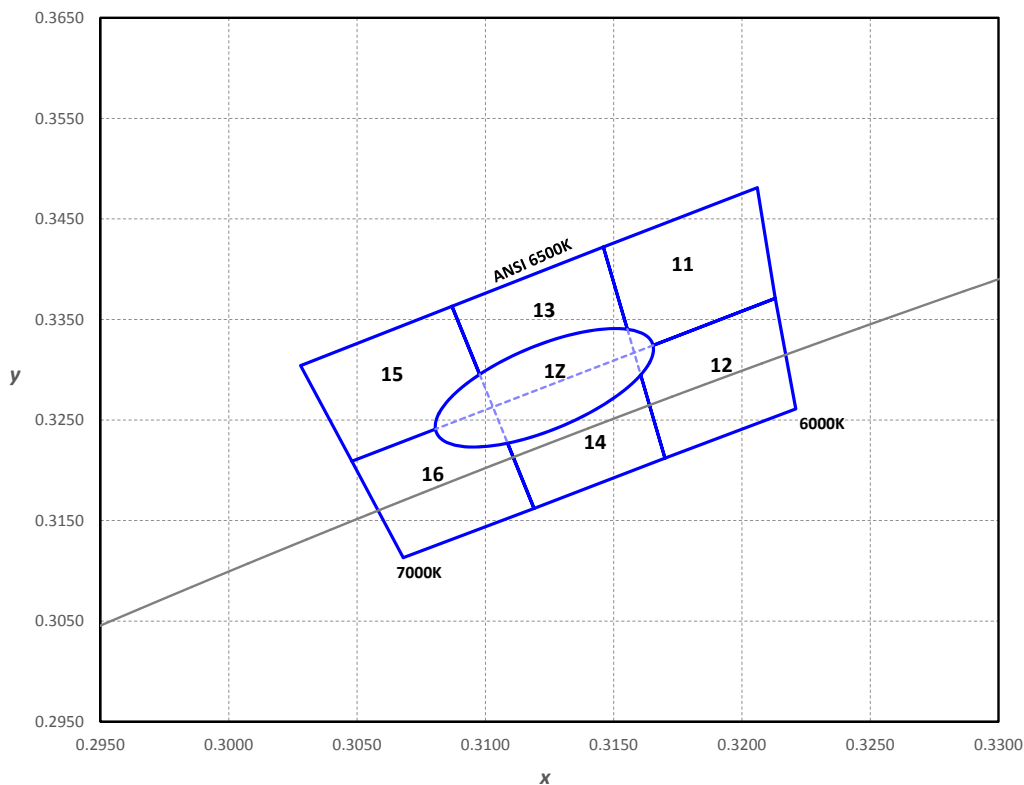

Figure 21. ANSI 6500K 1/7<sup>th</sup> color bin structure.

LUXEON 3535L LEDs are tested and binned by x,y coordinates.

Table 17.

| LUXEON 3535L ANSI 1/7 <sup>th</sup> Color Bin Coordinates for MXA8-PW65-xxxx Emitter |                     |        |            |            |                        |
|--|---------------------|--------|------------|------------|------------------------|
| Bin Code   | x                   | y      | Bin Code   | x          | y                      |
| 11   | 0.3158              | 0.3317 | 14         | 0.3119     | 0.3162                 |
|  | 0.3146              | 0.3422 |            | 0.3103     | 0.3263                 |
|  | 0.3206              | 0.3481 |            | 0.3158     | 0.3317                 |
|  | 0.3213              | 0.3371 |            | 0.3170     | 0.3212                 |
| 12   | 0.3170              | 0.3212 | 15         | 0.3048     | 0.3209                 |
|  | 0.3158              | 0.3317 |            | 0.3028     | 0.3304                 |
|  | 0.3213              | 0.3371 |            | 0.3087     | 0.3363                 |
|  | 0.3221              | 0.3261 |            | 0.3103     | 0.3263                 |
| 13   | 0.3103              | 0.3263 | 16         | 0.3068     | 0.3113                 |
|  | 0.3087              | 0.3363 |            | 0.3048     | 0.3209                 |
|  | 0.3146              | 0.3422 |            | 0.3103     | 0.3263                 |
|  | 0.3158              | 0.3317 |            | 0.3119     | 0.3162                 |
| Color Space  | Target Center Point |        | Major Axis | Minor Axis | Ellipse Rotation Angle |
|  | cx                  | cy     |            |            |                        |
| 1Z   | 0.3123              | 0.3282 | 0.00669    | 0.00285    | 58.57                  |

Notes for Table 17:

1. Tested and binned at 25°C and I<sub>f</sub> = 100mA. Tester tolerance: ±0.007 in x and y coordinates.

# About Lumileds

Lumileds is the light engine leader, delivering innovation, quality, and reliability.

For 100 years, Lumileds commitment to innovation has helped customers pioneer breakthrough products in the automotive, consumer and illumination markets.

Lumileds is shaping the future of light with our LEDs and automotive lamps, and helping our customers illuminate how people see the world around them.

To learn more about our portfolio of light engines visit [www.lumileds.com](http://www.lumileds.com).



©2015 Lumileds Holding B.V. All rights reserved.  
LUXEON is a registered trademark of the Lumileds Holding B.V.  
in the United States and other countries.

[www.lumileds.com](http://www.lumileds.com)

Neither Lumileds Holding B.V. nor its affiliates shall be liable for any kind of loss of data or any other damages, direct, indirect or consequential, resulting from the use of the provided information and data. Although Lumileds Holding B.V. and/or its affiliates have attempted to provide the most accurate information and data, the materials and services information and data are provided "as is," and neither Lumileds Holding B.V. nor its affiliates warrants or guarantees the contents and correctness of the provided information and data. Lumileds Holding B.V. and its affiliates reserve the right to make changes without notice. You as user agree to this disclaimer and user agreement with the download or use of the provided materials, information and data.