

# Cree® XLamp® MX-6 LEDs



## PRODUCT DESCRIPTION

The Cree XLamp MX-6 LED provides the proven lighting-class performance and reliability of Cree XLamp LEDs in a flat-top PLCC package. The XLamp MX-6 LED continues Cree’s history of innovation in LEDs for lighting applications with wide viewing angle, unlimited floor life, uniform light output without secondary optics and electrically neutral thermal path.

The XLamp MX-6 LED brings high performance and quality of light to a wide range of lighting applications, including linear lighting, LED light bulbs, fluorescent retrofits and retail-display lighting.

## FEATURES

- Available in white (2200 K and 2600 K to 8300 K CCT)
- Maximum drive current: 1000 mA
- Wide viewing angle: 120°
- Electrically neutral thermal path
- Qualification at max drive current
- Unlimited floor life at  $\leq 30\text{ }^{\circ}\text{C}/85\%\text{ RH}$
- RoHS- and REACh-compliant
- UL-recognized component (E326295)



## TABLE OF CONTENTS

Flux Characteristics.....	2
Characteristics .....	3
Relative Spectral Power Distribution.....	3
Relative Flux vs. Junction Temperature .....	4
Electrical Characteristics.....	4
Relative Flux vs. Current .....	5
Thermal Design.....	5
Typical Spatial Distribution.....	6
Reflow Soldering Characteristics ..	7
Notes.....	8
Mechanical Dimensions.....	9
Tape and Reel .....	10
Packaging.....	11

## FLUX CHARACTERISTICS (T<sub>j</sub> = 25 °C)

The following table provides several base order codes for XLamp MX-6 LEDs. It is important to note that the base order codes listed here are a subset of the total available order codes for the product family. For more order codes, as well as a complete description of the order-code nomenclature, please consult the XLamp MX-6 LED Binning & Labeling document.

Color	CCT Range		Base Order Codes Min. Luminous Flux (lm) @ 300 mA		Calculated Min. Luminous Flux (lm) @ 350 mA*	Order Code
	Min.	Max.	Group	Flux (lm)	Flux (lm)	
Cool White	5000 K	8300 K	Q5	107	122	MX6AWT-A1-0000-000D51
			R2	114	130	MX6AWT-A1-0000-000E51
			Q4	100	114	MX6AWT-A1-0000-000CE3
			Q5	107	122	MX6AWT-A1-0000-000DE3
80-CRI White	5000 K	8300 K	Q4	100	114	MX6AWT-H1-0000-000C51
			Q5	107	122	MX6AWT-H1-0000-000D51
			Q4	100	114	MX6AWT-H1-0000-000CE3
			Q5	107	122	MX6AWT-H1-0000-000DE3
	3700 K	4300 K	Q3	93.9	107	MX6AWT-H1-0000-000BE5
			Q4	100	114	MX6AWT-H1-0000-000CE5
	2600 K	3700 K	Q2	87.4	100	MX6AWT-H1-0000-000AE7
			Q3	93.9	107	MX6AWT-H1-0000-000BE7
Warm White	3700 K	4300 K	Q3	93.9	107	MX6AWT-A1-0000-000BE5
			Q4	100	114	MX6AWT-A1-0000-000CE5
	2600 K	3700 K	Q2	87.4	100	MX6AWT-A1-0000-000AE7
			Q3	93.9	107	MX6AWT-A1-0000-000BE7
	2200 K		P2	67.2	77	MX6AWT-A1-0000-0007EA
			P3	73.9	84	MX6AWT-A1-0000-0008EA
			P4	80.6	92	MX6AWT-A1-0000-0009EA

\* Calculated values for reference purposes only.

### Notes:

- Cree maintains a tolerance of  $\pm 7\%$  on flux and power measurements,  $\pm 0.005$  on chromaticity (CC<sub>x</sub>, CC<sub>y</sub>) measurements and  $\pm 2$  on CRI measurements.
- Typical CRI for Cool White (4300 K – 8300 K CCT) is 75.
- Typical CRI for Warm White (2200 K and 2600 K – 4300 K CCT) is 80.
- Minimum CRI for 80-CRI White is 80.

### CHARACTERISTICS

Characteristics	Unit	Minimum	Typical	Maximum
Thermal resistance, junction to solder point	°C/W		5	
Viewing angle (FWHM)	degrees		120	
Temperature coefficient of voltage	mV/°C		-3.3	
ESD classification (HBM per Mil-Std-883D)			Class 2	
DC forward current	mA			1000
Forward voltage (@ 300 mA)	V		3.3	3.8
LED junction temperature	°C			150

### RELATIVE SPECTRAL POWER DISTRIBUTION

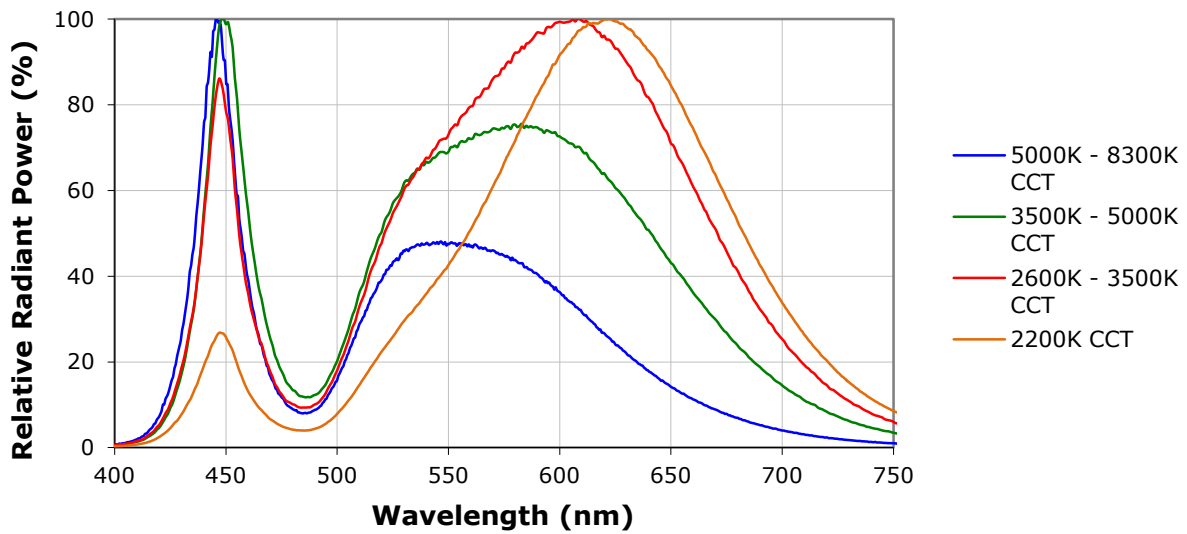

**RELATIVE FLUX VS. JUNCTION TEMPERATURE ( $I_f = 300 \text{ MA}$ )**

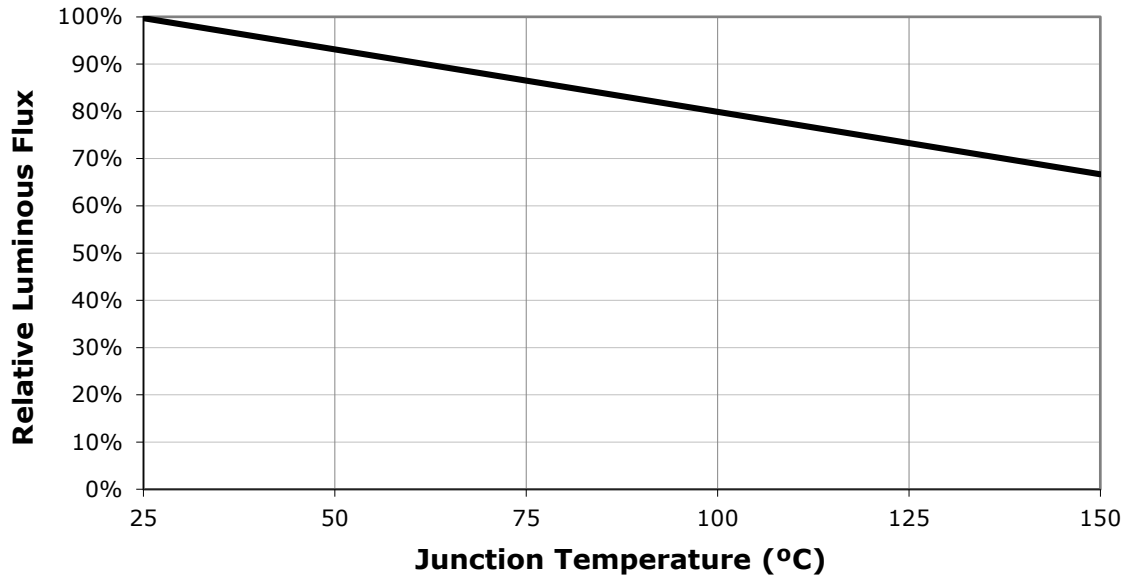

**ELECTRICAL CHARACTERISTICS ( $T_j = 25 \text{ °C}$ )**

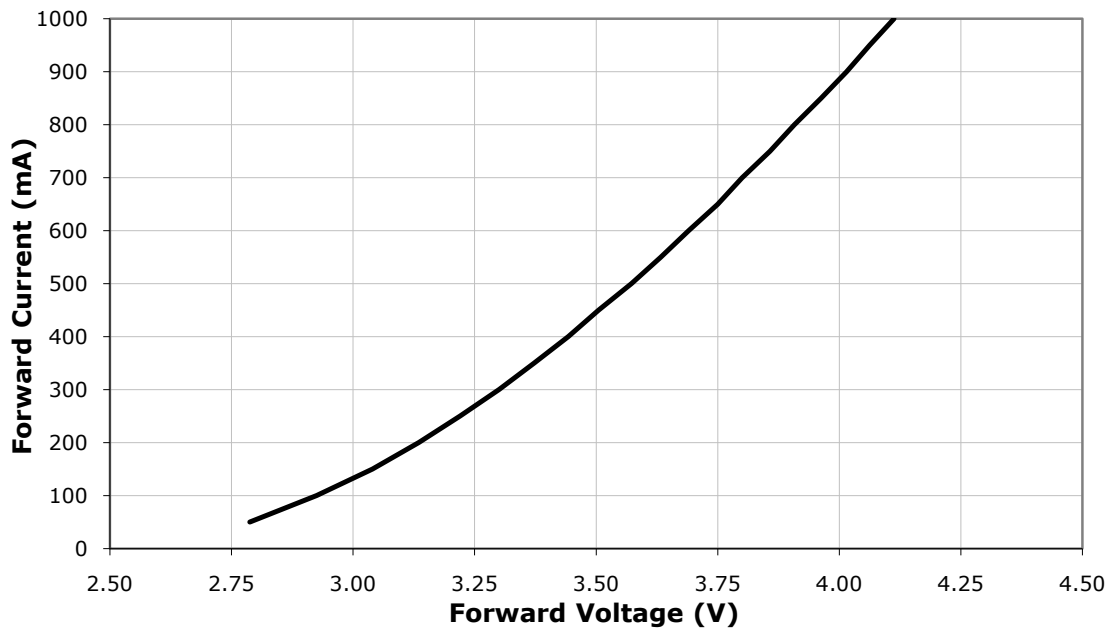

**RELATIVE FLUX VS. CURRENT ( $T_j = 25\text{ }^\circ\text{C}$ )**

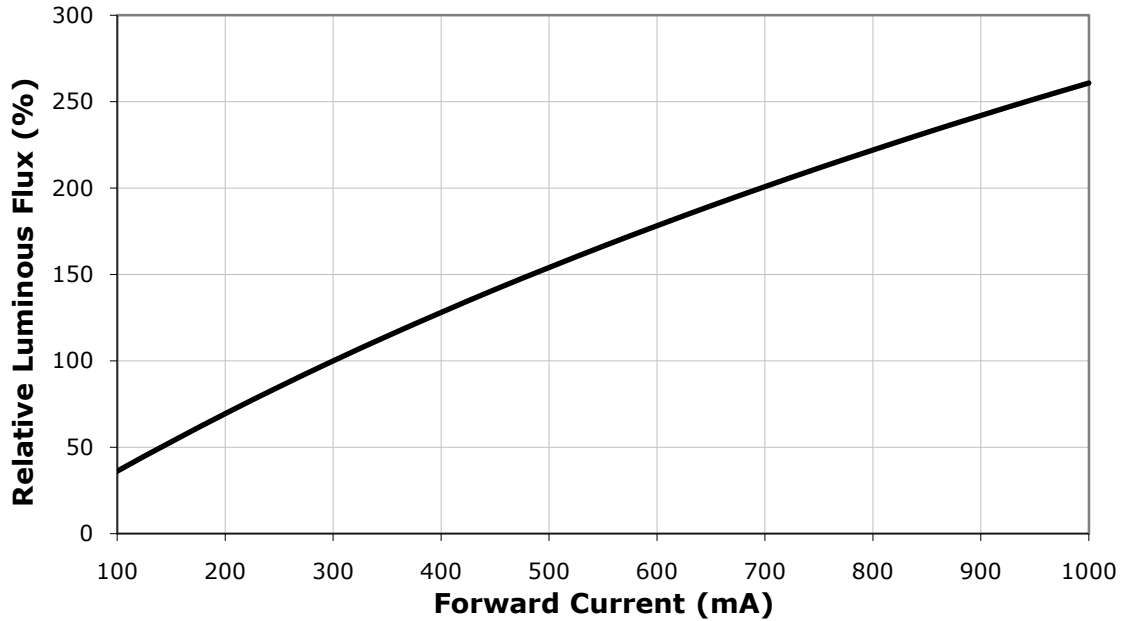

**THERMAL DESIGN**

The maximum forward current is determined by the thermal resistance between the LED junction and ambient. It is crucial for the end product to be designed in a manner that minimizes the thermal resistance from the solder point to ambient in order to optimize lamp life and optical characteristics.

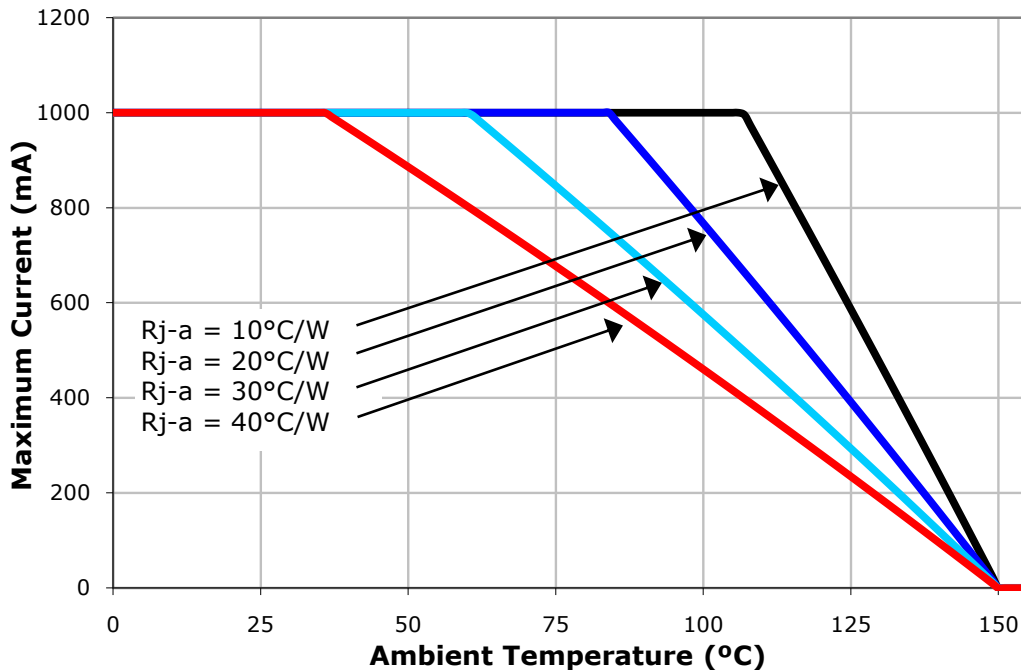

**TYPICAL SPATIAL DISTRIBUTION**

---

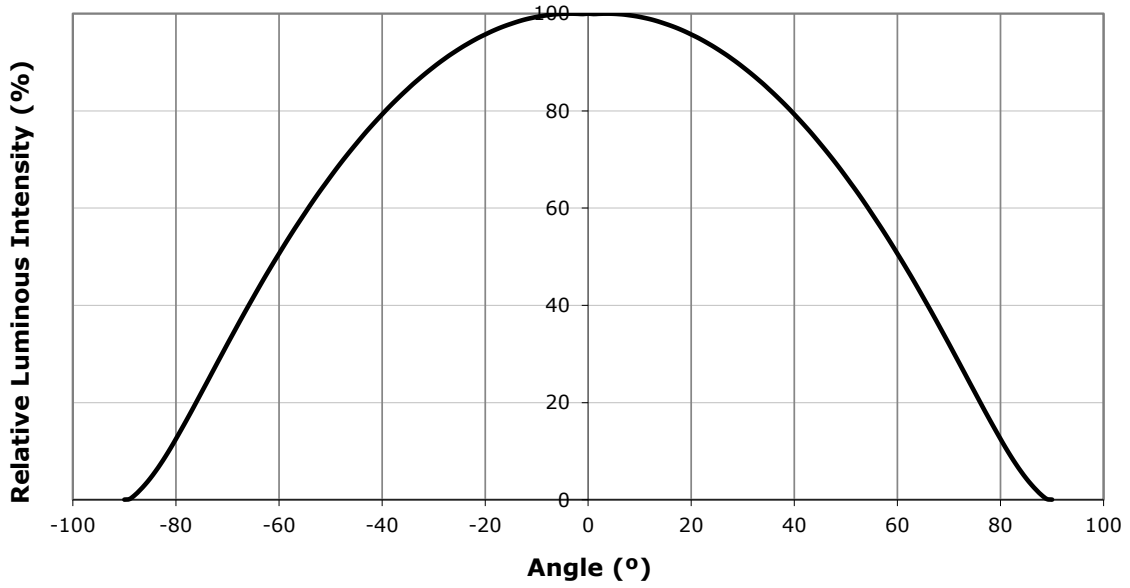

## REFLOW SOLDERING CHARACTERISTICS

In testing, Cree has found XLamp MX-6 LEDs to be compatible with JEDEC J-STD-020C, using the parameters listed below. As a general guideline, Cree recommends that users follow the recommended soldering profile provided by the manufacturer of solder paste used.

Note that this general guideline may not apply to all PCB designs and configurations of reflow soldering equipment.

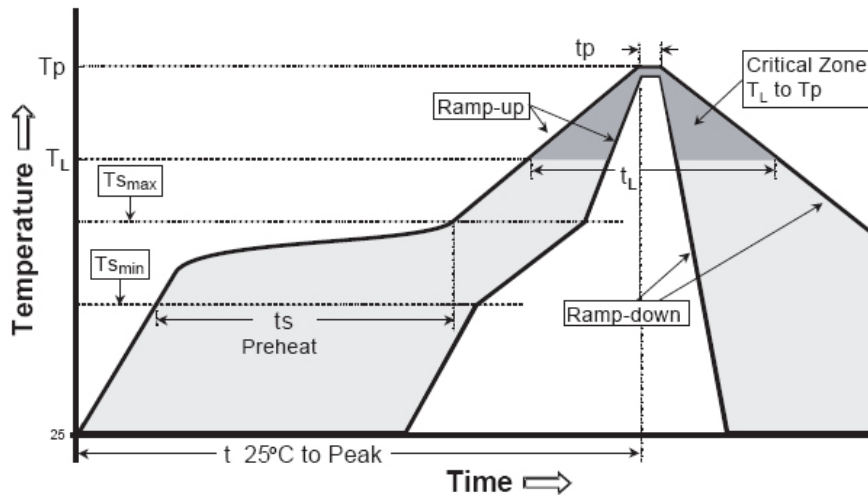

IPC/JEDEC J-STD-020C

Profile Feature	Lead-Based Solder	Lead-Free Solder
Average Ramp-Up Rate ( $T_{smax}$ to $T_p$ )	3 °C/second max.	3 °C/second max.
Preheat: Temperature Min ( $T_{smin}$ )	100 °C	150 °C
Preheat: Temperature Max ( $T_{smax}$ )	150 °C	200 °C
Preheat: Time ( $t_{smin}$ to $t_{smax}$ )	60-120 seconds	60-180 seconds
Time Maintained Above: Temperature ( $T_L$ )	183 °C	217 °C
Time Maintained Above: Time ( $t_L$ )	60-150 seconds	60-150 seconds
Peak/Classification Temperature ( $T_p$ )	215 °C	260 °C
Time Within 5 °C of Actual Peak Temperature ( $t_p$ )	10-30 seconds	20-40 seconds
Ramp-Down Rate	6 °C/second max.	6 °C/second max.
Time 25 °C to Peak Temperature	6 minutes max.	8 minutes max.

Note: All temperatures refer to the topside of the package, measured on the package body surface.

## NOTES

---

### Lumen Maintenance Projections

Cree now uses standardized IES LM-80-08 and TM-21-11 methods for collecting long-term data and extrapolating LED lumen maintenance. For information on the specific LM-80 data sets available for this LED, refer to the public LM-80 results document at [www.cree.com/xlamp\\_app\\_notes/LM80\\_results](http://www.cree.com/xlamp_app_notes/LM80_results).

Please read the XLamp Long-Term Lumen Maintenance application note at [www.cree.com/xlamp\\_app\\_notes/XRE\\_lumen\\_maintenance](http://www.cree.com/xlamp_app_notes/XRE_lumen_maintenance) for more details on Cree's lumen maintenance testing and forecasting. Please read the XLamp Thermal Management application note at [www.cree.com/xlamp\\_app\\_notes/thermal\\_management](http://www.cree.com/xlamp_app_notes/thermal_management) for details on how thermal design, ambient temperature and drive current affect the LED junction temperature.

### ENERGY STAR Recommendation

Cree currently recommends a maximum drive current of 600 mA for XLamp MX-6 white LEDs in designs seeking the ENERGY STAR\* 35,000-hour lifetime rating ( $\geq 94.1\%$  luminous flux @ 6,000 hours) or 25,000-hour lifetime rating ( $\geq 91.8\%$  luminous flux @ 6,000 hours).

\* These lifetime ratings are based on the current ENERGY STAR Product Specification for Luminaires (Light Fixtures) V1.0 (February 16, 2011) and ENERGY STAR Program Requirements for Integral LED Lamps V1.4 (May 13, 2011) lumen maintenance criteria.

### Moisture Sensitivity

In testing, Cree has found XLamp MX-6 LEDs to have unlimited floor life in conditions  $\leq 30\text{ }^{\circ}\text{C}/85\%$  relative humidity (RH). Moisture testing included a 168-hour soak at  $85\text{ }^{\circ}\text{C}/85\%$  RH followed by 3 reflow cycles, with visual and electrical inspections at each stage.

Cree recommends keeping XLamp LEDs in their sealed moisture-barrier packaging until immediately prior to use. Cree also recommends returning any unused LEDs to the resealable moisture-barrier bag and closing the bag immediately after use.

### RoHS Compliance

The levels of environmentally sensitive, persistent biologically toxic (PBT), persistent organic pollutants (POP), or otherwise restricted materials in this product are below the maximum concentration values (also referred to as the threshold limits) permitted for such substances, or are used in an exempted application, in accordance with EU Directive 2002/95/EC on the restriction of the use of certain hazardous substances in electrical and electronic equipment (RoHS), as amended through April 21, 2006.

### Vision Advisory Claim

**WARNING:** Do not look at an exposed lamp in operation. Eye injury can result. See LED Eye Safety at [www.cree.com/xlamp\\_app\\_notes/led\\_eye\\_safety](http://www.cree.com/xlamp_app_notes/led_eye_safety).

**MECHANICAL DIMENSIONS**

All measurements are  $\pm .13$  mm unless otherwise indicated.

Top View

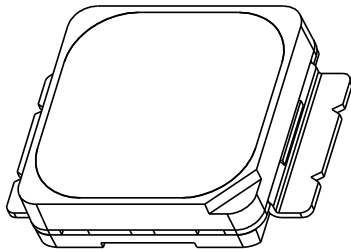

Top View

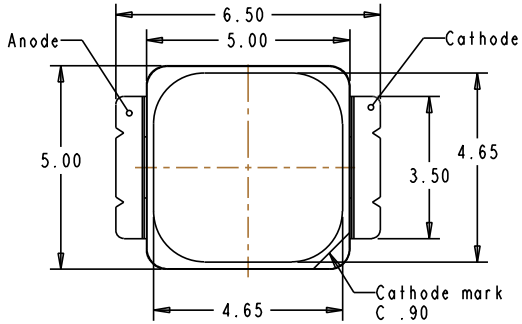

Bottom View

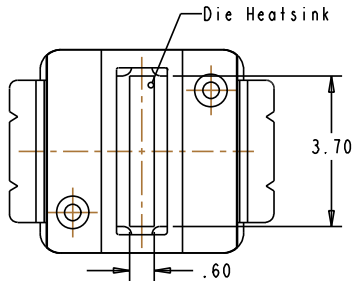

Side View

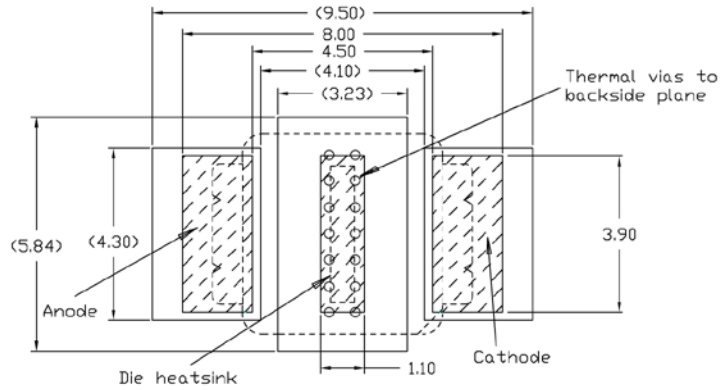
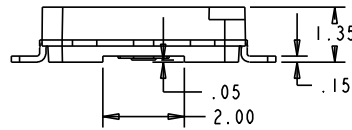

Recommended FR4 Solder Pad

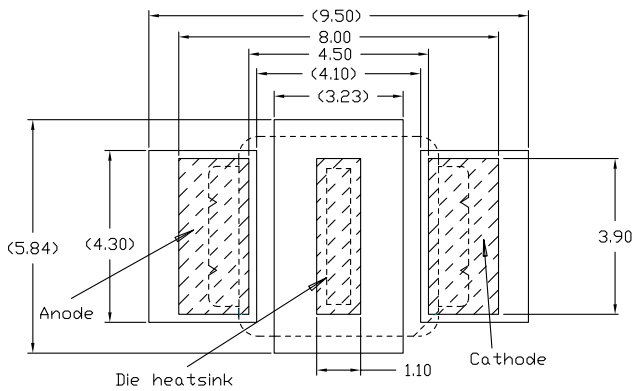

Recommended MCPCB Solder Pad

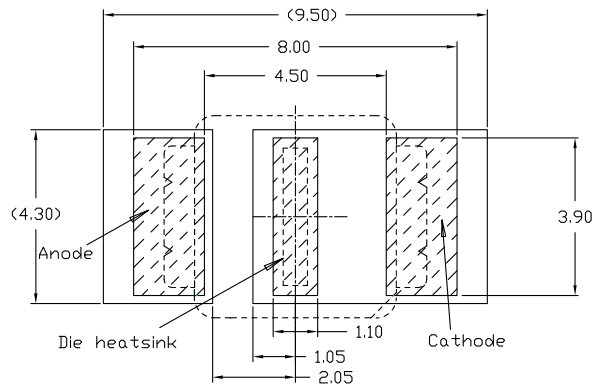

Alternative Solder Pad

**TAPE AND REEL**

All Cree carrier tapes conform to EIA-481D, Automated Component Handling Systems Standard.

All dimensions in mm.

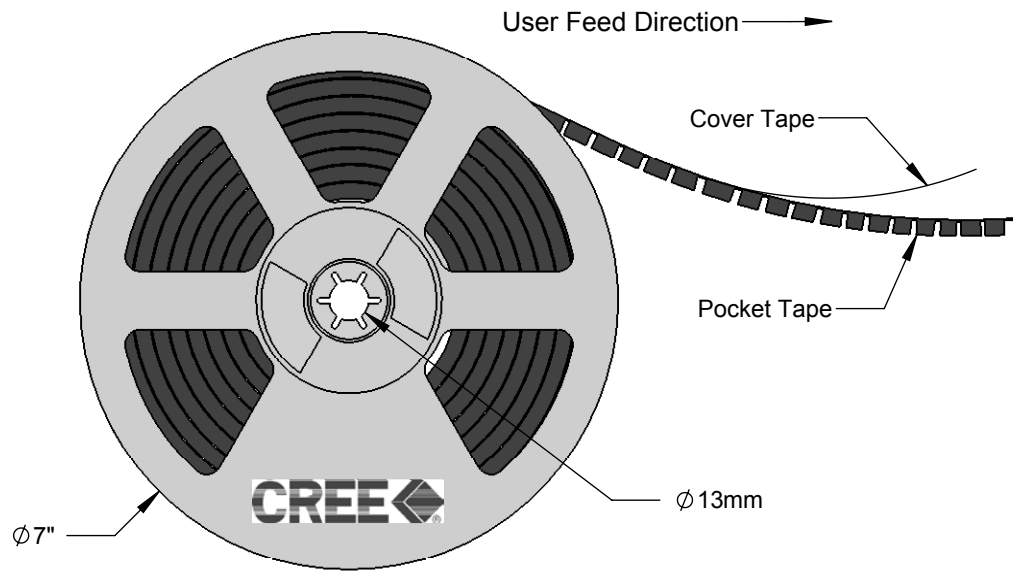
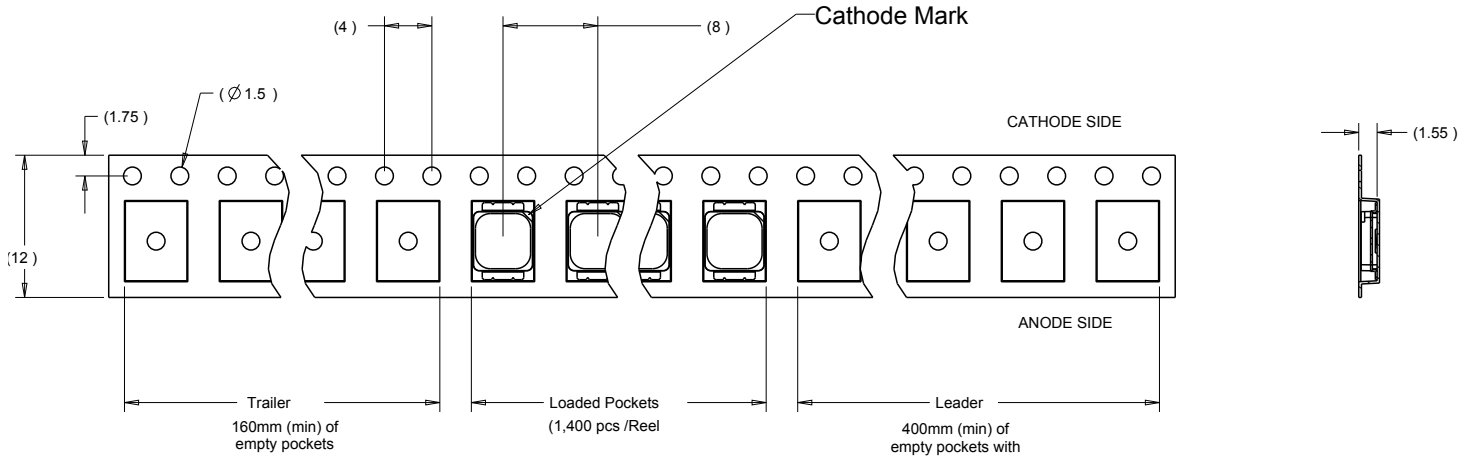

## PACKAGING

### Unpackaged Reel

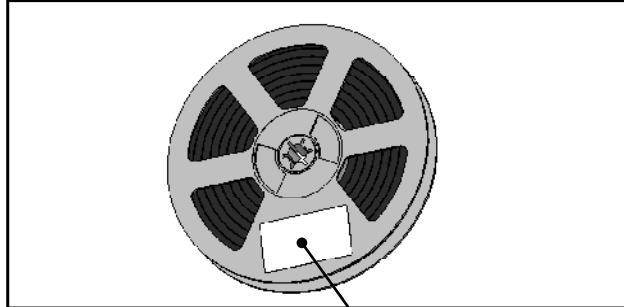

Label with Cree Bin Code, Qty, Reel ID

### Packaged Reel

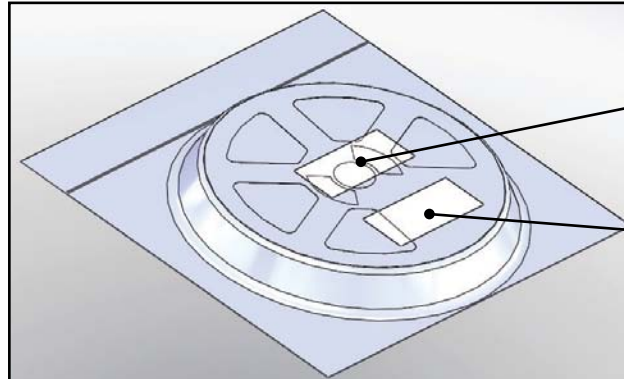

Label with Cree Order Code, Qty, Reel ID, PO #

Label with Cree Bin Code, Qty, Reel ID

### Boxed Reel

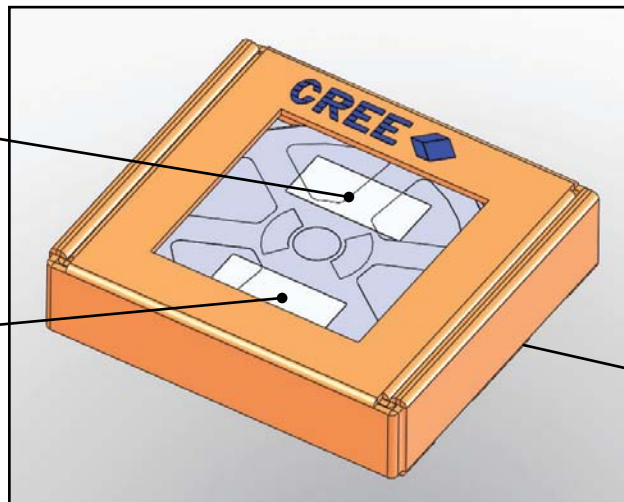

Label with Cree Order Code, Qty, Reel ID, PO #

Label with Cree Bin Code, Qty, Reel ID

Patent Label (on bottom of box)