

# Cree® XLamp® MX-3 LEDs



## PRODUCT DESCRIPTION

The Cree XLamp MX-3 LED provides the proven lighting-class performance and reliability of Cree XLamp LEDs in a flat-top PLCC package. The XLamp MX-3 LED continues Cree’s history of innovation in LEDs for lighting applications with a wide viewing angle, unlimited floor life, uniform light output without secondary optics and electrically neutral thermal path.

The XLamp MX-3 LED brings high performance and quality of light to a wide range of lighting applications, including linear lighting, LED light bulbs, fluorescent retrofits and retail-display lighting.

## FEATURES

- Available in white (2,600 K to 8,300 K CCT)
- Maximum drive current: 400 mA
- Wide viewing angle: 120°
- Electrically neutral thermal path
- Qualification at max drive current
- RoHS-compliant
- Unlimited floor life at ≤ 30°C/85% RH

## TABLE OF CONTENTS

Flux Characteristics.....	2
Characteristics .....	2
Relative Spectral Power Distribution.....	3
Relative Flux vs. Junction Temperature .....	3
Electrical Characteristics.....	4
Relative Flux vs. Current .....	4
Thermal Design.....	5
Typical Spatial Distribution.....	5
Reflow Soldering Characteristics ..	6
Notes.....	7
Mechanical Dimensions.....	8
Tape and Reel .....	9
Packaging.....	10

## FLUX CHARACTERISTICS (T<sub>j</sub> = 25°C)

The following table provides several base order codes for XLamp MX-3 LEDs. It is important to note that the base order codes listed here are a subset of the total available order codes for the product family. For more order codes, as well as a complete description of the order-code nomenclature, please consult the XLamp MX-3 LED Binning and Labeling document.

Color	CCT Range		Base Order Codes Min Luminous Flux (lm) @ 350 mA		Calculated Min Luminous Flux (lm) @ 300 mA*	Order Code
	Min.	Max.	Group	Flux (lm)	Flux (lm)	
Cool White	5,000 K	8,300 K	Q5	107	93.9	MX3AWT-A1-0000-000D51
			R2	114	100	MX3AWT-A1-0000-000E51
Warm White	3,700 K	4,300 K	Q4	100	87	MX3AWT-A1-0000-000CE5
	2,600 K	3,700 K	Q3	93.9	82	MX3AWT-A1-0000-000BE7

\* Calculated values for reference purposes only.

### Notes:

- Cree maintains a tolerance of +/- 7% on flux measurements.
- Typical CRI for Cool White (4,300 K – 8,300 K CCT) is 75.
- Typical CRI for Warm White (2,600 K – 4,300 K CCT) is 80.

## CHARACTERISTICS

Characteristics	Unit	Minimum	Typical	Maximum
Thermal resistance, junction to solder point	°C/W		11	
Viewing angle (FWHM)	degrees		120	
Temperature coefficient of voltage	mV/ °C		-27	
ESD classification (HBM per Mil-Std-883D)			Class 2	
DC forward current	mA			400
Forward voltage (@ 350 mA)	V		3.7	4.0
LED junction temperature	°C			150

**RELATIVE SPECTRAL POWER DISTRIBUTION**

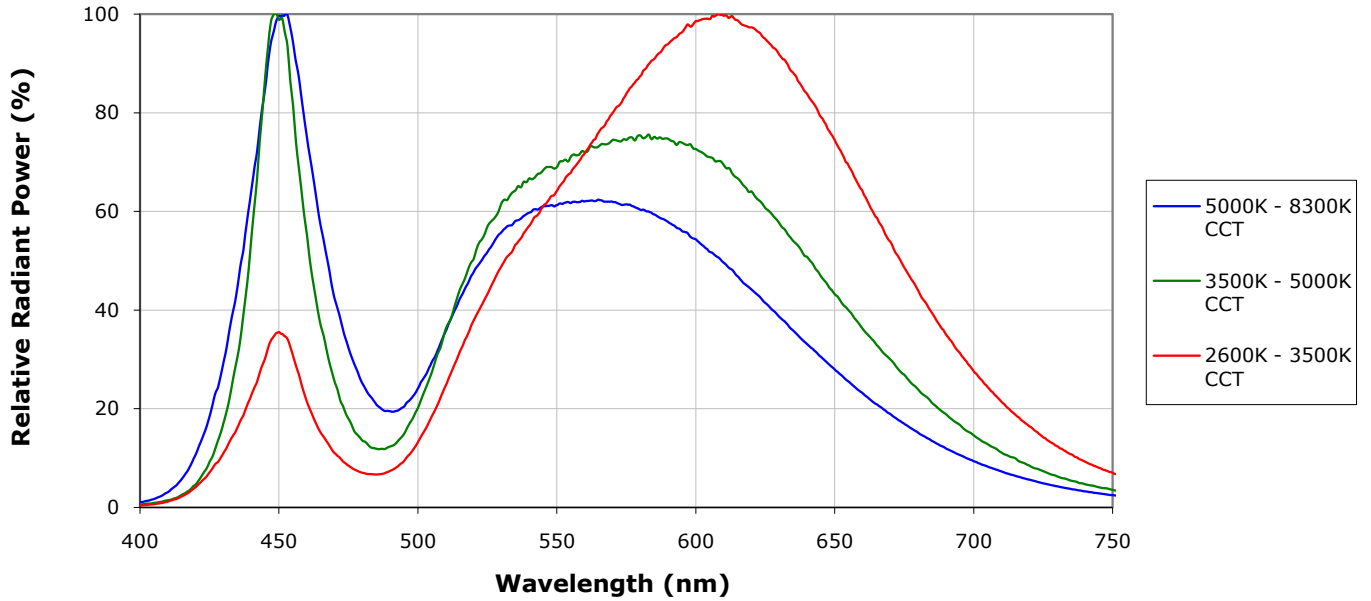

**RELATIVE FLUX VS. JUNCTION TEMPERATURE ( $I_F = 350$  MA)**

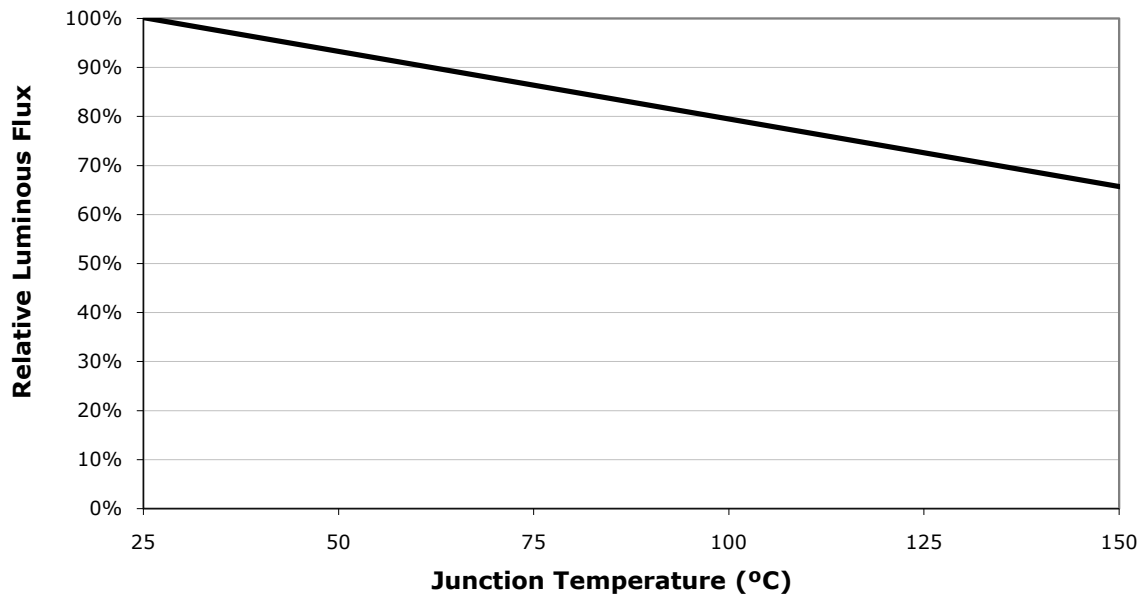

**ELECTRICAL CHARACTERISTICS ( $T_j = 25^\circ\text{C}$ )**

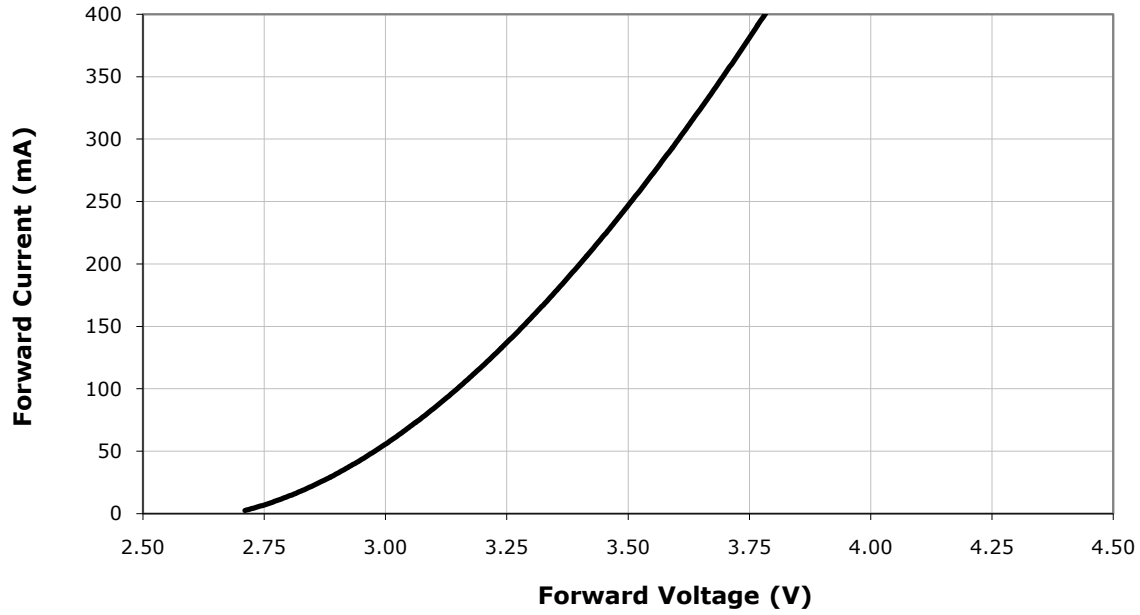

**RELATIVE FLUX VS. CURRENT ( $T_j = 25^\circ\text{C}$ )**

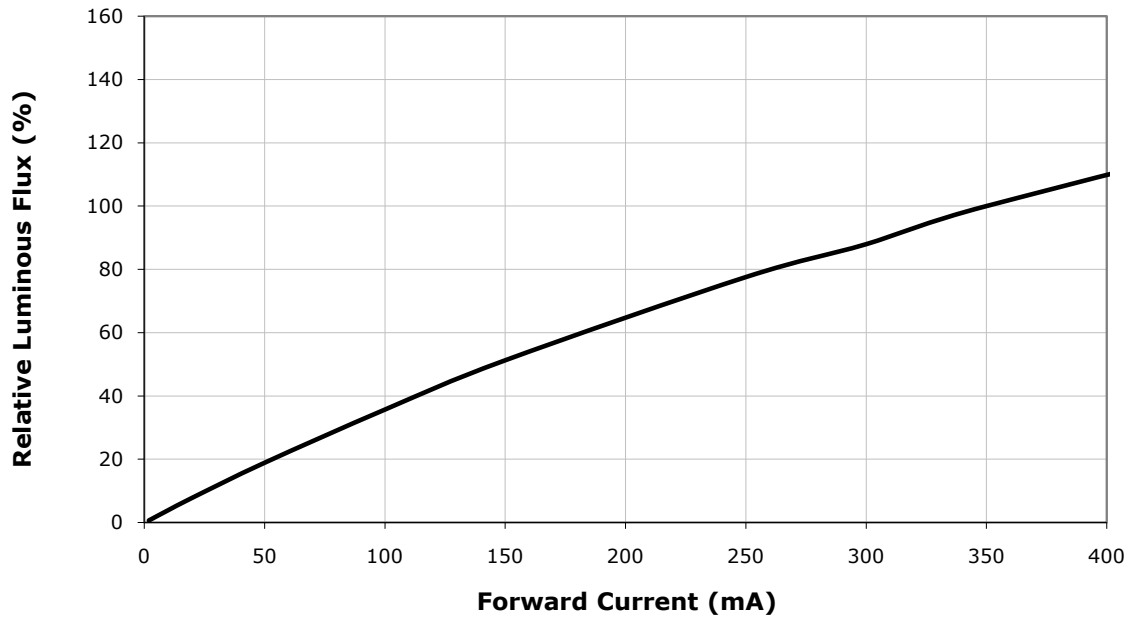

**THERMAL DESIGN**

The maximum forward current is determined by the thermal resistance between the LED junction and ambient. It is crucial for the end product to be designed in a manner that minimizes the thermal resistance from the solder point to ambient in order to optimize lamp life and optical characteristics.

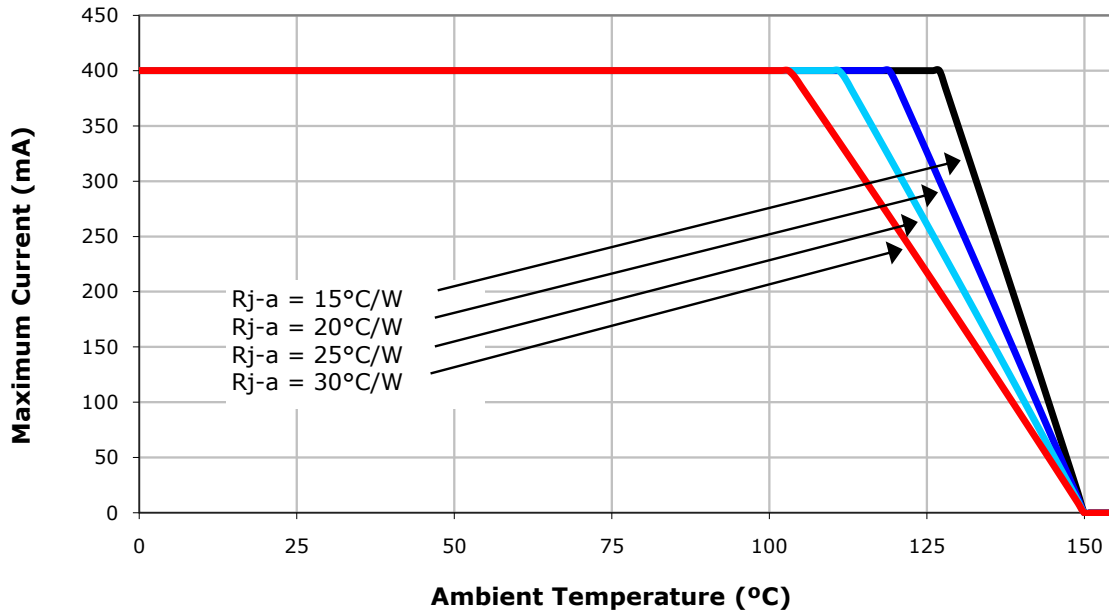

**TYPICAL SPATIAL DISTRIBUTION**

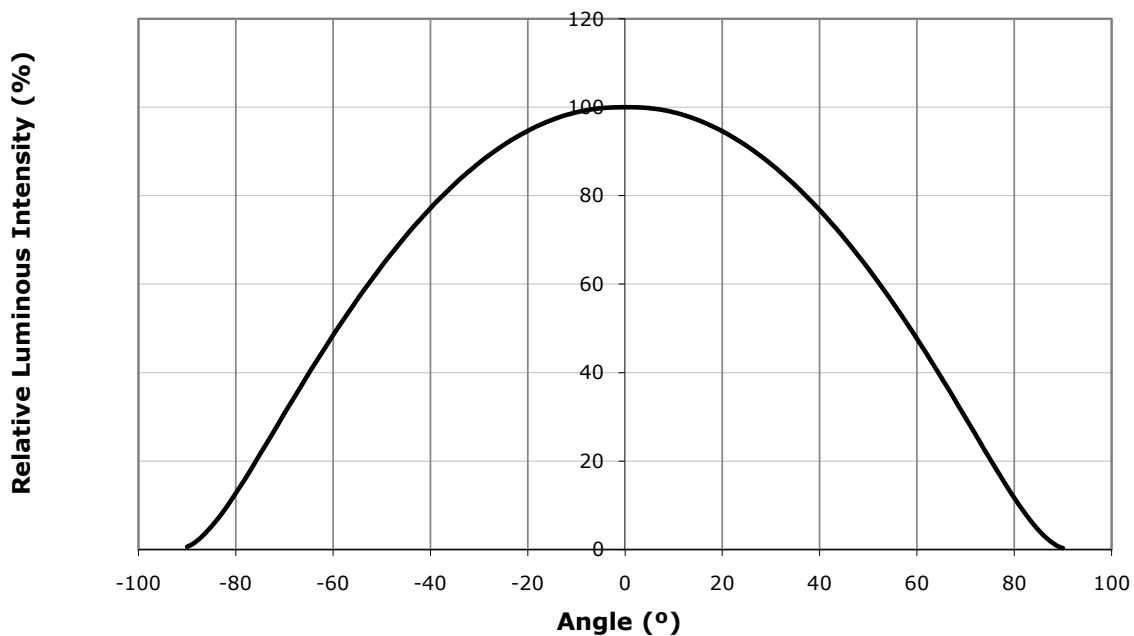

## REFLOW SOLDERING CHARACTERISTICS

In testing, Cree has found XLamp XM-L LEDs to be compatible with JEDEC J-STD-020C, using the parameters listed below. As a general guideline, Cree recommends that users follow the recommended soldering profile provided by the manufacturer of solder paste used.

Note that this general guideline may not apply to all PCB designs and configurations of reflow soldering equipment.

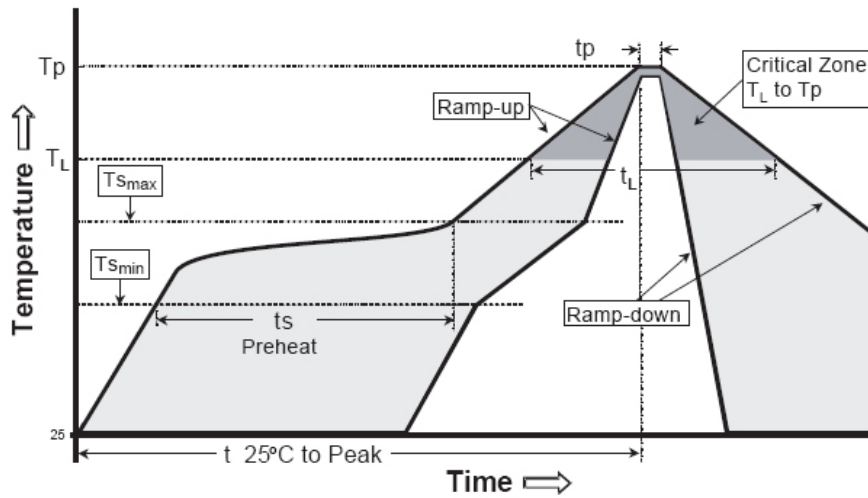

IPC/JEDEC J-STD-020C

Profile Feature	Lead-Based Solder	Lead-Free Solder
Average Ramp-Up Rate ( $T_{smax}$ to $T_p$ )	3°C/second max.	3°C/second max.
Preheat: Temperature Min ( $T_{smin}$ )	100°C	150°C
Preheat: Temperature Max ( $T_{smax}$ )	150°C	200°C
Preheat: Time ( $t_{smin}$ to $t_{smax}$ )	60-120 seconds	60-180 seconds
Time Maintained Above: Temperature ( $T_L$ )	183°C	217°C
Time Maintained Above: Time ( $t_L$ )	60-150 seconds	60-150 seconds
Peak/Classification Temperature ( $T_p$ )	215°C	260°C
Time Within 5°C of Actual Peak Temperature ( $t_p$ )	10-30 seconds	20-40 seconds
Ramp-Down Rate	6°C/second max.	6°C/second max.
Time 25°C to Peak Temperature	6 minutes max.	8 minutes max.

Note: All temperatures refer to the topside of the package, measured on the package body surface.

## NOTES

---

### Moisture Sensitivity

In testing, Cree has found XLamp MX-3 LEDs to have unlimited floor life in conditions  $\leq 30^{\circ}\text{C}$  / 85% relative humidity (RH). Moisture testing included a 168 hour soak at  $85^{\circ}\text{C}$  / 85% RH followed by 3 reflow cycles, with visual and electrical inspections at each stage.

### RoHS Compliance

The levels of environmentally sensitive, persistent biologically toxic (PBT), persistent organic pollutants (POP), or otherwise restricted materials in this product are below the maximum concentration values (also referred to as the threshold limits) permitted for such substances, or are used in an exempted application, in accordance with EU Directive 2002/95/EC on the restriction of the use of certain hazardous substances in electrical and electronic equipment (RoHS), as amended through April 21, 2006.

### Vision Advisory Claim

Users should be cautioned not to stare at the light of this LED product. The bright light can damage the eye.

**MECHANICAL DIMENSIONS**

All measurements are  $\pm .13$  mm unless otherwise indicated.

Top View

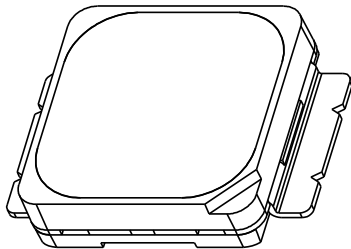

Top View

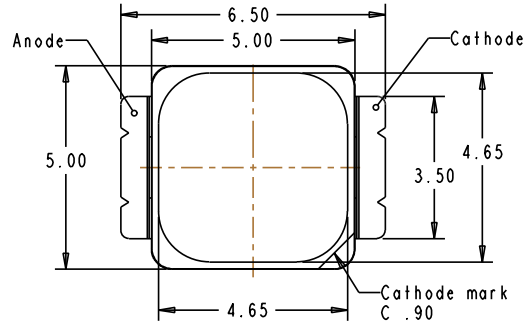

Bottom View

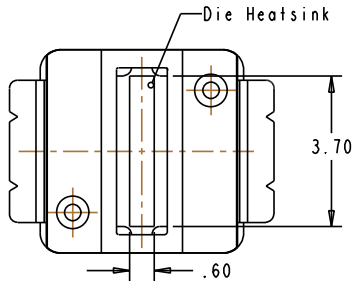

Side View

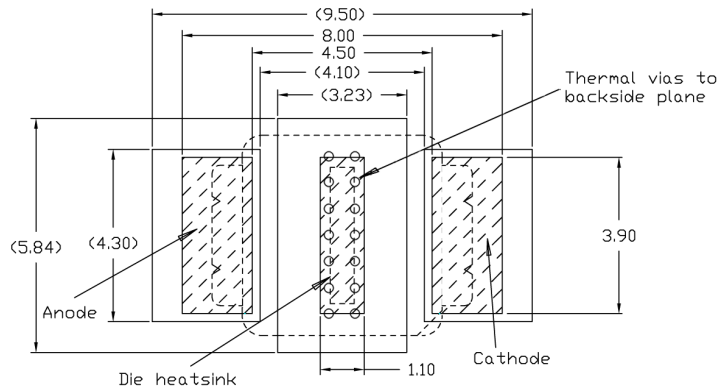
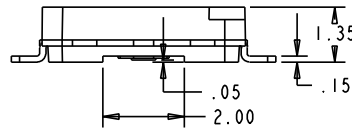

Recommended FR4 Solder Pad

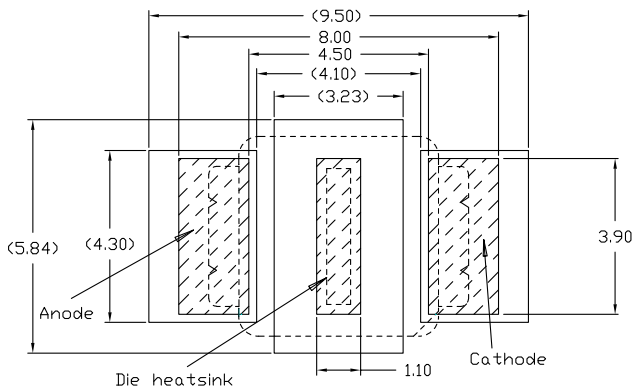

Recommended MCPCB Solder Pad

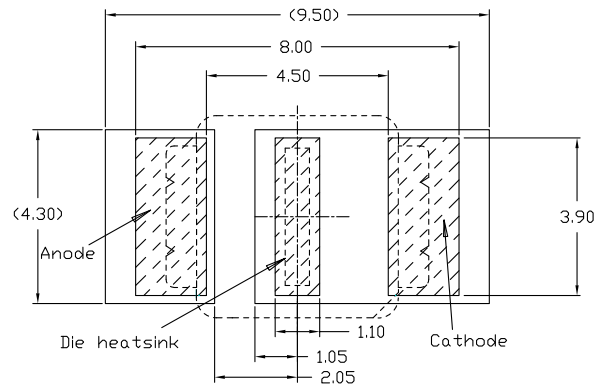

Alternative Solder Pad

**TAPE AND REEL**

All dimensions in mm.

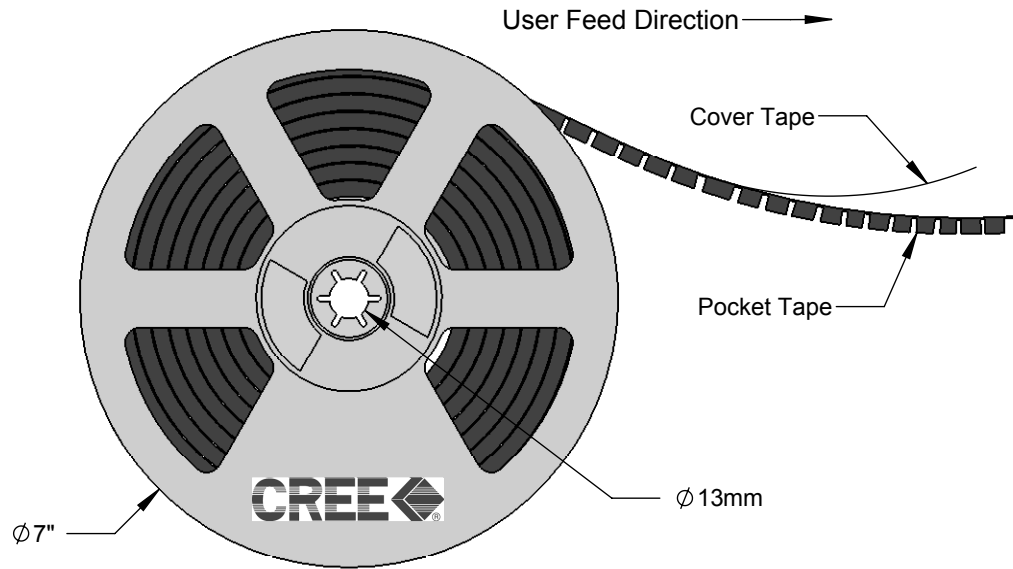
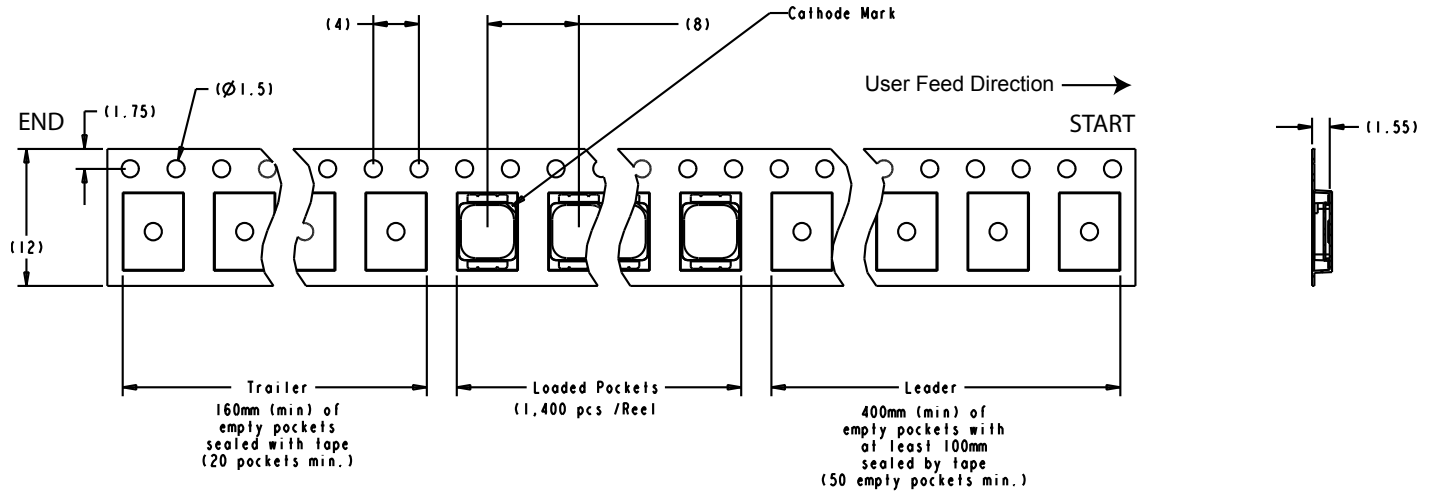

### PACKAGING

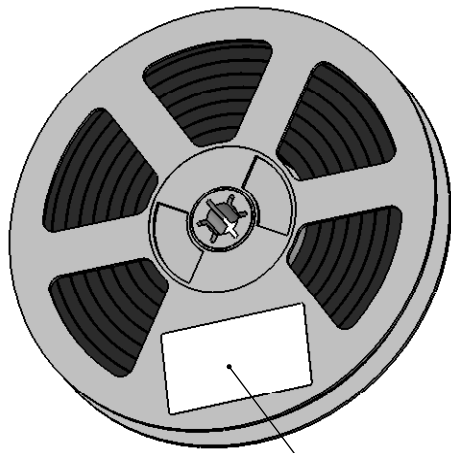

Label with Cree Bin Code, Qty, Lot #

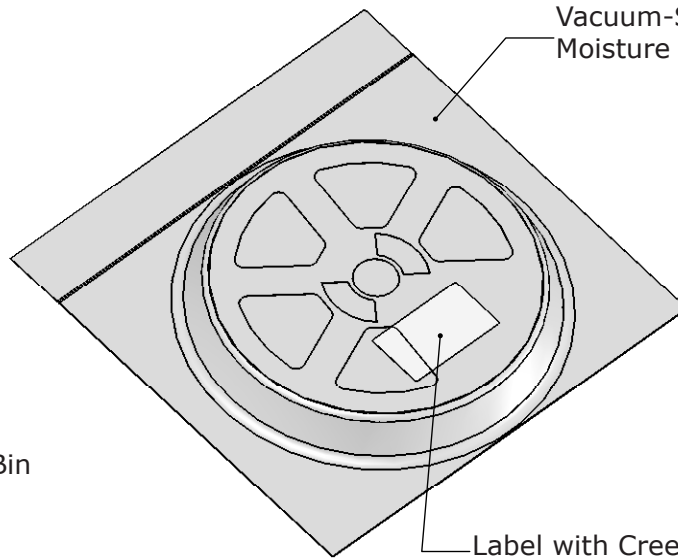

Vacuum-Sealed Moisture Barrier Bag

Label with Cree Bin Code, Qty, Lot #

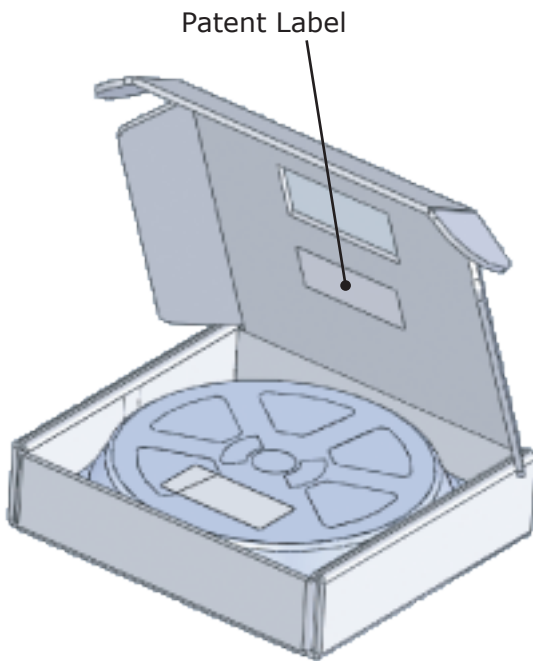

Patent Label

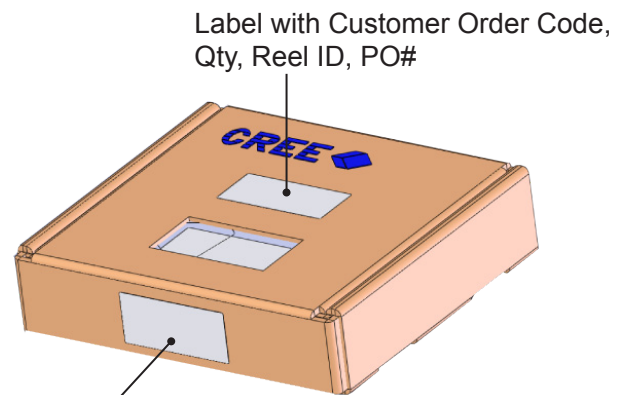

Label with Customer Order Code, Qty, Reel ID, PO#

Label with Cree Bin Code, Qty, Lot #