

— MTC30



- COTS Component for Defense & Avionics Applications
- Single & Dual Output Models
- Environmental Performance to MIL-STD 810
- 10 to 50 VDC Transient Input Range
- 15 to 40 VDC Steady State Input Range
- 35W Max Output Power
- -55°C to 100°C Operation
- Cooling Plates and Mounting Holes for Easy Integration
- Synchronous Rectification on Low Voltage Outputs
- MIL-STD 461 EMI Performance
- Frequency Synchronization
- Thermal Warning (Battle Mode) Signal



Introduction

The MTC30 is a COTS DC-DC converter developed specifically for the defense and avionics market. This product has a full military specification while offering the short lead-times and cost benefits of a COTS component.

The MTC30 uses a forward converter design switching at 450 kHz giving excellent size, efficiency and EMC performance. The input range is designed to provide short term operation over 10 - 50 VDC to enable the converter to work at full power through the dips and surges commonly seen in vehicle and aircraft applications. A soft start circuit provides well-controlled outputs with no overshoot.

Comprehensive control functions such as voltage trim, remote sense, inhibit and frequency synchronization to an external source are standard features. The MTC30 contains an over temperature warning signal (battle mode) that gives user control over the temperature shutdown function of the converter.

The internal filtering meets the conducted emission requirements of MIL-STD 461E/F/G without external components. When used in conjunction with the MTF input filter module the MTC30 complies to MIL-STD 461E/F/G CE/CS, MIL-STD 1275A-E and MIL-STD 704A-F.

Input Characteristics

Characteristic	Minimum	Typical	Maximum	Units	Notes & Conditions
Input Voltage	15.5	28	40	VDC	Continuous
Transient Input Voltage Range	10		50	VDC	10V for 10 s, 50V for 1 s at full load
UVLO Turn On	13.5		14.8	VDC	
UVLO Turn Off	8.5		9.8	VDC	
Maximum Input Current				A	See models and ratings table for details
Inhibited Input Current		4.9		mA	Verified by measurement
Inrush Current		52		A	Peak value
Input Reverse Voltage Protection					External components required

Output Characteristics

Characteristic	Minimum	Typical	Maximum	Units	Notes & Conditions
Output Voltage				VDC	See models and ratings table for details
Output Current				A	See models and ratings table for details
Output Set Tolerance			±100	mV	
Minimum Load	0			A	No minimum load required
Ripple & Noise Vout ≤5V Vout >5V		40	60 1	mV %	pk-pk at 100% load and 20 MHz BW 100% load and 20 MHz BW
Overvoltage Protection ⁽¹⁾	110		120	%	Vout nominal
Overload Protection	105		150	%	At Vin nominal
Overcurrent Protection	105		150	%	Dual outputs only, at Vin nominal
Overtemperature Protection ⁽²⁾	102		107	°C	Baseplate temp. with 2°C to 5°C hysteresis
Remote Sense			0.5	V	Total voltage compensation
Load Regulation			±1	%	Vout nominal
Cross Regulation			1	%	Dual outputs only. V1 at Inom, V2 75-100% Inom. See curves for non-symmetrical loads.
Load Step Output Transient			±3	%	Vout nominal 75-25% or 25-75% load changes
Load Step Recovery			500	µs	Within 1% of Vout nom
Line Regulation			±1	%	Vout nominal at 15.5-40 Vin
Line Step Output Transient			±3	%	Vout nominal at 15.5-40 Vin
Line Step Recovery			500	µs	Time for Vout to recover to 1% of Vout nom, with line step 15.5-40 Vin
Maximum Output Capacitance			300 x Iout max	µF	
Start Up Time		45		ms	See fig. 17 to 20

1. Overvoltage protection can be removed by factory, add suffix "-NV" to the part number, e.g. MTC3028S05-NV.

2. For the option without overtemperature protection add suffix "-NT" to the part number, e.g. MTC3028S05-NT.

Models & Ratings

Max Output Power	Output Voltage			Output Current		Input Current ⁽³⁾		Efficiency	Model Number
	Nominal	Min ⁽¹⁾	Max ⁽¹⁾	Inom	I _{max} ⁽⁴⁾	No Load	Full Load		
20 W	3.3 VDC	3.3 VDC	4.0 VDC	6.06 A	N/A	0.06 A	0.89 A	80%	MTC3028S3V3
25 W	5 VDC	4.0 VDC	6.0 VDC	5.00 A	N/A	0.09 A	1.08 A	83%	MTC3028S05
32 W	12 VDC	9.0 VDC	13.8 VDC ⁽²⁾	2.70 A	N/A	0.05 A	1.41 A	81%	MTC3028S12
35 W	15 VDC	11.0 VDC	17.0 VDC ⁽²⁾	2.33 A	N/A	0.06 A	1.54 A	81%	MTC3028S15
35 W	28 VDC	20.0 VDC	30.0 VDC	1.25 A	N/A	0.07 A	1.51 A	83%	MTC3028S28
30 W	±12 VDC	N/A	N/A	±1.25 A	±2.00 A	0.04 A	1.33 A	81%	MTC3028D12
30 W	±15 VDC	N/A	N/A	±1.00 A	±1.60 A	0.04 A	1.33 A	80%	MTC3028D15

1. Indicates maximum and minimum voltage adjustment (Maximum includes Remote Sense adjustment).

2. The full trim range is not available when the input is <15.5V.

3. Vin = 28 VDC

4. Maximum output power must not exceed 30 W.

General Specifications

Characteristic	Minimum	Typical	Maximum	Units	Notes & Conditions
Efficiency				%	See models table and performance graphs
Isolation Voltage			1500	VDC	Input to output
			1000	VDC	Input to case
			500	VDC	Output to case
Switching Frequency	400	450	500	kHz	Frequency synch 400-500 kHz. See note
MTBF	See table				
Inhibit	On = TTL High or open circuit; Off = TTL Low or short circuit				
Rth Case - Ambient	Output Voltage			Rth Case - Ambient	
		3.3 V		9.2 °C/W	
		5 V		9.3 °C/W	
		12 V		8.7 °C/W	
		15 V		8.6 °C/W	
		28 V		8.8 °C/W	
		±12 V		8.7 °C/W	
		±15 V		8.7 °C/W	

Note. Control signal needs to be TTL 0-5 VDC square wave. The trigger is the falling edge.

Environmental

Characteristic	Minimum	Typical	Maximum	Units	Notes & Conditions
Operating Case Temperature	-40		+100	°C	Baseplate temperature
Extended Temperature Range	-55		+100	°C	Baseplate temperature. See note.
Storage Temperature	-55		+125	°C	
Humidity			95	%	Relative humidity
Altitude			70000	Ft	MIL-STD 810D Method 500.2
Salt Atmosphere			48	hrs	MIL-STD 810E Method 509.3
Shock			100	g	MIL-STD 810D Method 516.3 crash hazard for ground equipment
Vibration	5		500	Hz	MIL-STD 810D Method 514.3 basic transportation
Bump			40	g	2000 bumps in each axes MIL-STD 810D Method 516.3 crash hazard

Note. For -55 °C extended operating range, add suffix '-LT' to the part number. e.g. MTC3028S05-LT

Electromagnetic Compatibility

	Standard	Test Level	Criteria	Notes & Conditions
Conducted Emissions	MIL-STD-461E/F/G	CE101/CE102		
	DEF-STAN-59-41	TBA		MTF50 module is required
Immunity	MIL-STD-1275A-E	Spikes Surges Ripple	±250 V for 100 µs 100 V for 50 ms (see note) 14 VAC pk-pk	MTF50 module is required
	MIL-STD-704A	600 V input transient	10µs 50Ω source impedance	MTF50 module is required
	MIL-STD-704B-F		50 V for 10 ms	
Conducted Susceptibility	MIL-STD-461E/F/G	CS101, CS114, CS115, CS116		MTF50 module is required

Note. 0.5 Ω source impedance

Safety Approvals

Standard	Category
CE	LVD

MTBF Calculations - Single Outputs

Temperature / Environment	Ground Mobile - GM	Airbourne Inhabited Cargo - AIC	Airbourne Inhabited Fighter - AIF
20 °C	572508 Hrs	511768 Hrs	248881 Hrs
40 °C	388615 Hrs	344869 Hrs	165992 Hrs
60 °C	268016 Hrs	237025 Hrs	113839 Hrs
80 °C	186666 Hrs	165178 Hrs	79883 Hrs
100 °C	130030 Hrs	115636 Hrs	56976 Hrs

MTBF Calculations - Dual Outputs

Temperature / Environment	Ground Mobile - GM	Airbourne Inhabited Cargo - AIC	Airbourne Inhabited Fighter - AIF
20 °C	559576 Hrs	537722 Hrs	288094 Hrs
40 °C	372929 Hrs	364801 Hrs	193225 Hrs
60 °C	247825 Hrs	247508 Hrs	131394 Hrs
80 °C	163916 Hrs	167263 Hrs	90213 Hrs
100 °C	107298 Hrs	111652 Hrs	62208 Hrs

Synchronization

The recommended level for the synchronization is a TTL signal but slightly higher levels may be used without a problem. However the maximum positive level should not exceed 5V. The ideal synchronization signal is a pulse of minimum of 200ns and low and high levels of <0.8V and 4V to 5V respectively within a frequency range of 400kHz to 500kHz. The trigger is the falling edge of the signal and the impedance of the sync pin is >10kohm. If the synchronization feature is not required the sync pin is recommended to be connected to ground to prevent any abnormal interference.

Thermal Warning (TW)

The thermal warning pin is an open collector output and it can be used for an over-temperature protection up to 107 °C by connecting it to the inhibit pin. When the base-plate temperature of the converter is between 102 °C and 107 °C the transistor will be switched on and will pull the inhibit pin to ground. If the TW pin is not connected the converter will run without over-temperature protection. This could be used during battle when the part will operate until destroy itself due to overheating.

Overload Protection

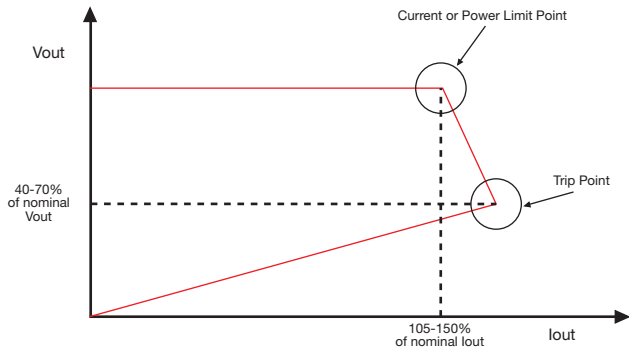

Figure 1. Overload Protection

MTC3028SXX has overload protection. After reaching the limit between 105% to 150% of I_{nom} (current or power limit point) it will reduce the output voltage protecting the converter from overheating. When V_{out} nom is in the range of 40% to 70% the power will drop to 0 (trip point). The unit will attempt to restart after 700ms typical.

MTC3028DXX has overload protection similar to the single outputs when both outputs are loaded symmetrically. In addition, each output also has an individual current limit between 105% to 150% of I_{max} to protect applications with non-symmetrical loads.

Remote Sensing - Single Output Models Only

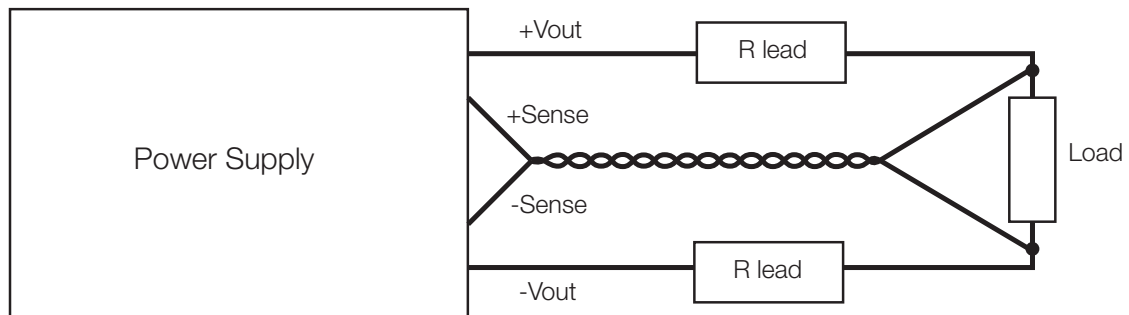

Figure 2. MTC30 - Remote Sense Connection Diagram

Notes.

1. To use the remote sense connect +Sense pin to +Vout and -Sense pin to -Vout.
2. When remote sense is not in use leave pins not connected or connected locally to $\pm V_{out}$.

Voltage Trim - Single Output Models Only

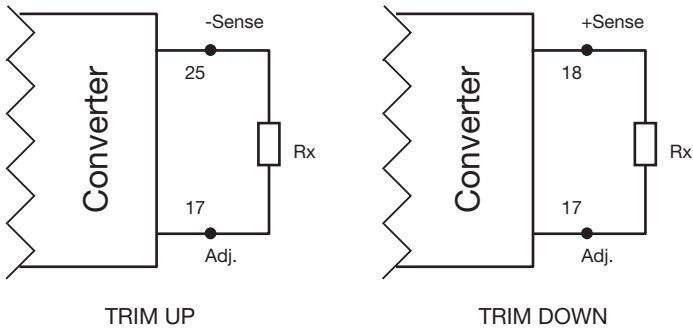

Figure 3. MTC30 - Trim connections

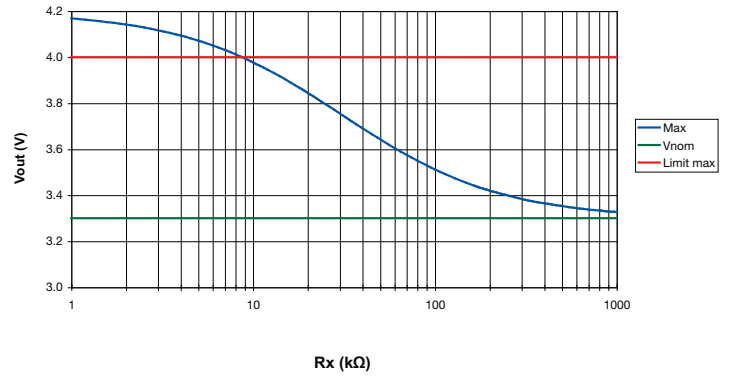

Figure 4. MTC3028S3V3 - Max and Min Adjustment

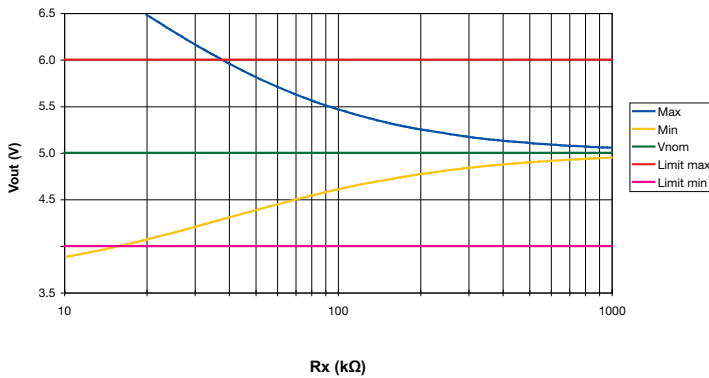

Figure 5. MTC3028S05 - Max and Min Adjustment

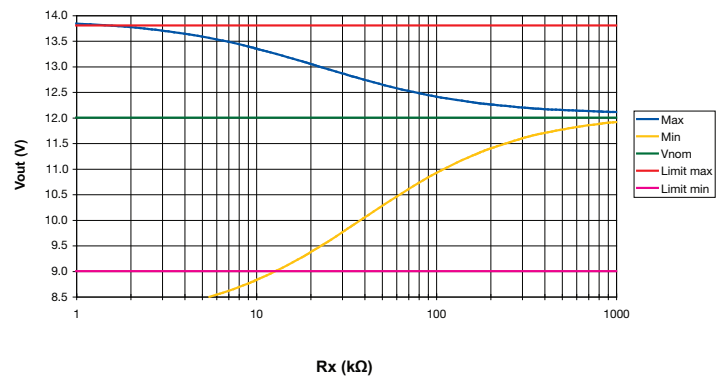

Figure 6. MTC3028S12 - Max and Min Adjustment

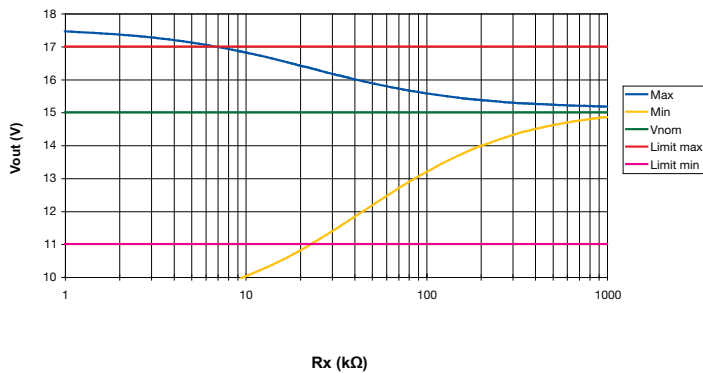

Figure 7. MTC3028S15 - Max and Min Adjustment

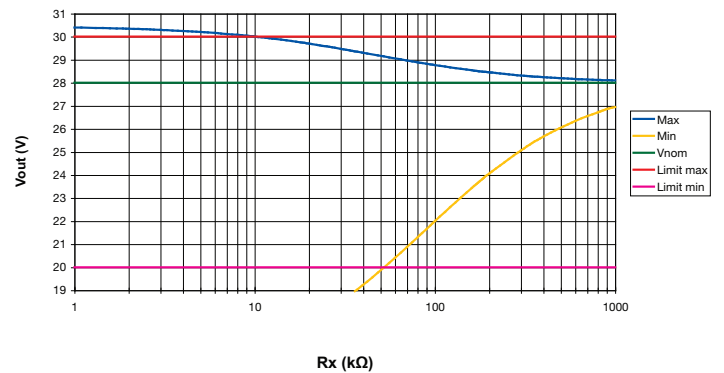

Figure 8. MTC3028S28 - Max and Min Adjustment

- Notes.**
1. When adjusting the output voltage do not go above the max. output voltage limit (refer to tables) as the overvoltage protection may be triggered when fitted.
 2. When adjusting the output voltage do not go below the specified voltage range (refer to tables) as input and output characteristics can not be guaranteed.
 3. When not in use leave Adj. pin not-connected.

EMC Performance Curve Examples

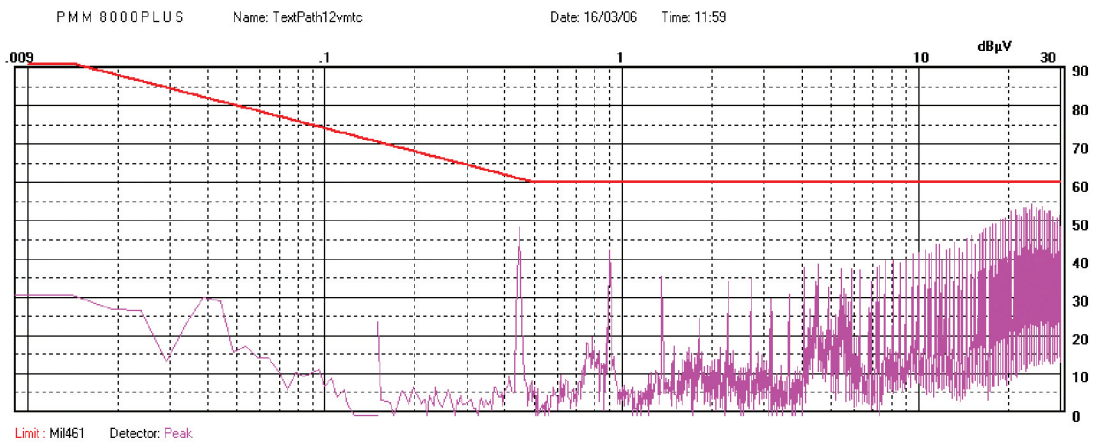

Figure 9. MTC3028S12 without a filter

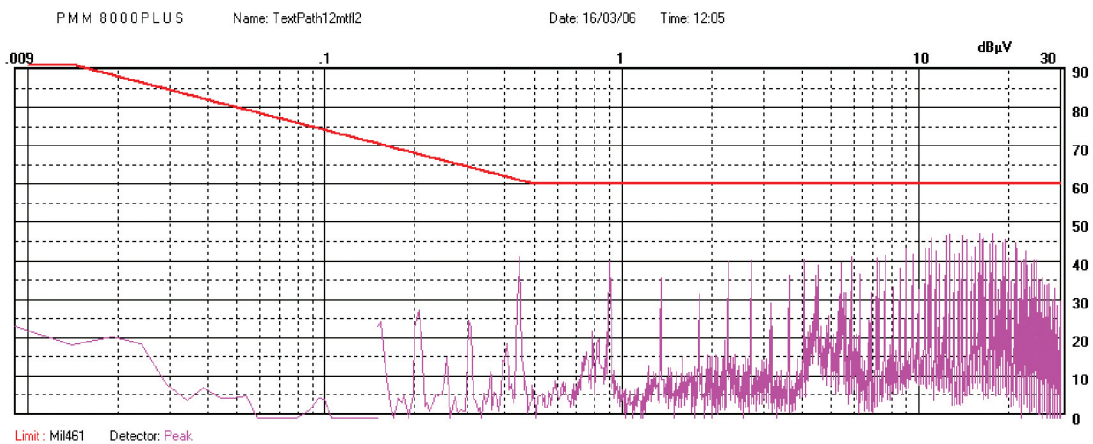

Figure 10. MTC3028S12 with MTF50 filter

EMC Filter Connection Diagram

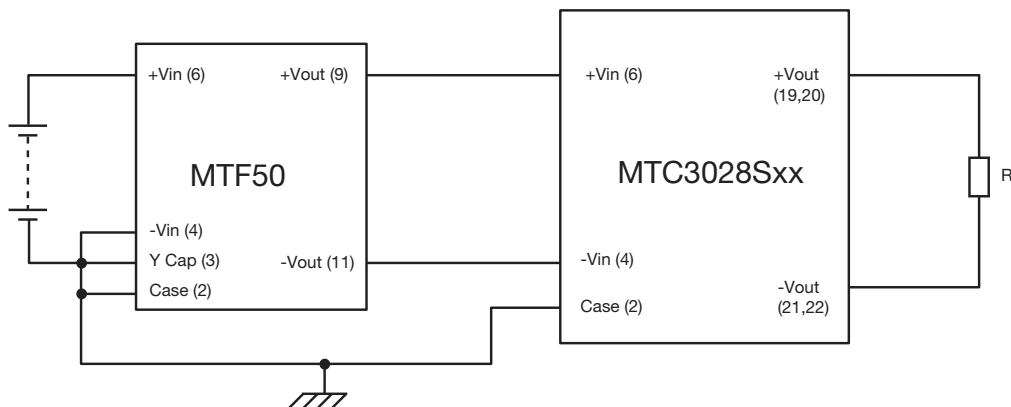

Figure 11. MTC30 - EMC Filter connection diagram

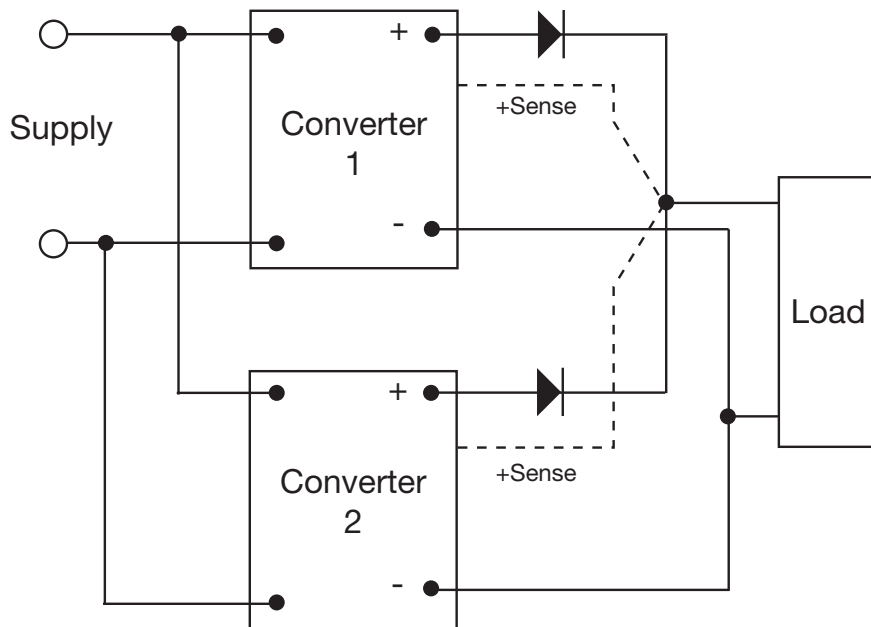

Figure 12. Parallel configuration suitable for redundant operation

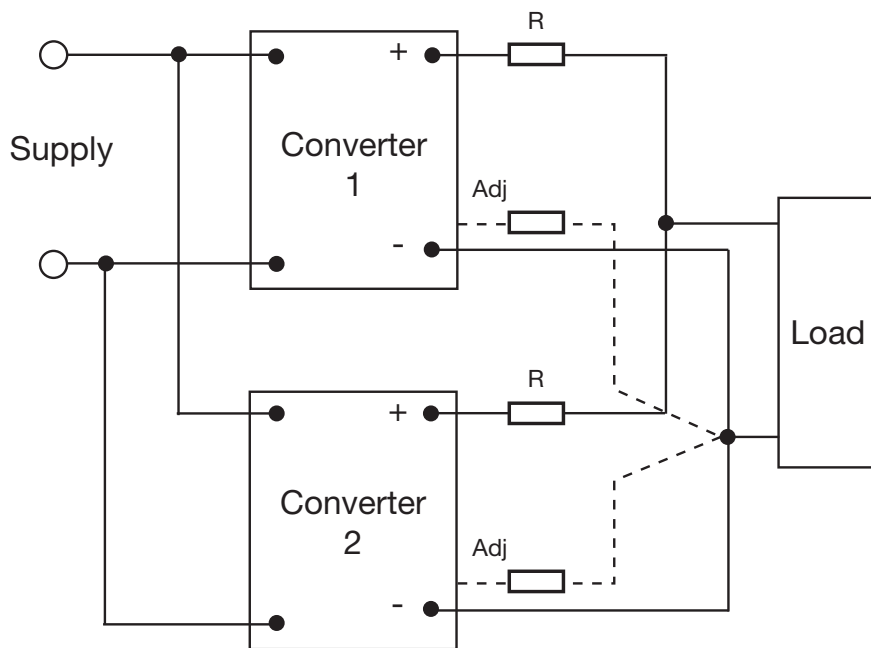

Figure 13. Parallel configuration for current sharing

Notes.

1. Up to 3 converters to share within 80% max power;
2. To calculate the resistor (R) for the current sharing use the formula: $R = (V_{out\ nom} (V) \times \text{output set tolerance } (\%)) / (I_{out\ nom} (A) \times \text{current share } (\%))$, e.g. MTC3028S05 will be: $R = (5V \times 4\%) / (5A \times 50\%) = 800m\Omega$
3. The adjust pin can be used to tune V_{out} to achieve max of 1% tolerance which helps to achieve better current sharing and keeps the resistor (R) value lower.

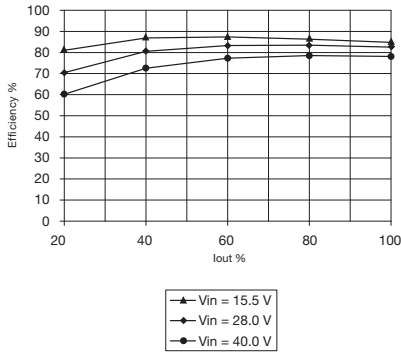

Figure 14. Typical efficiency for MTC3028S05

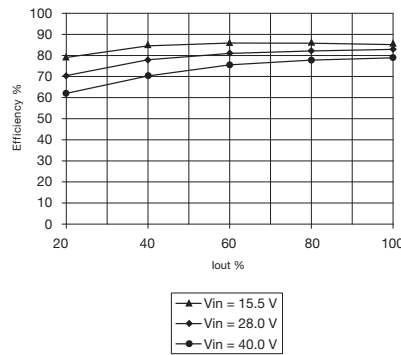

Figure 15. Typical efficiency for MTC3028S28

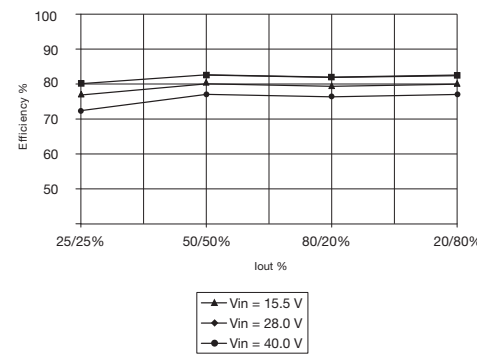

Figure 16. Typical efficiency for MTC3028D15

Start Up Time

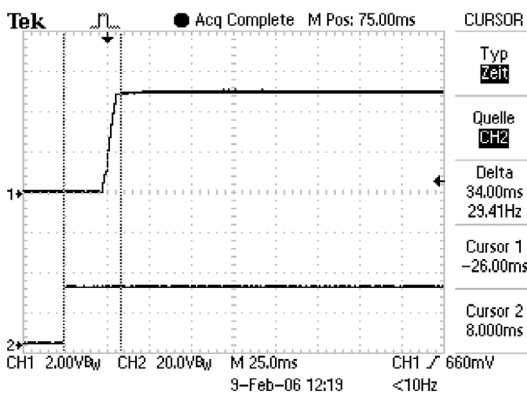

Figure 17. Start up time for MTC3028S05 with full resistive load - 34 ms

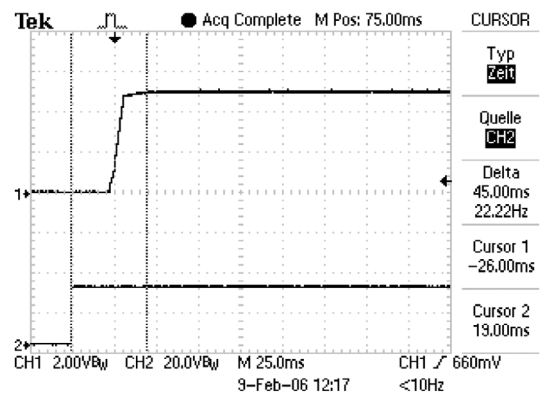

Figure 18. Start up time for MTC3028S05 at full load and 1500 µF - 45 ms

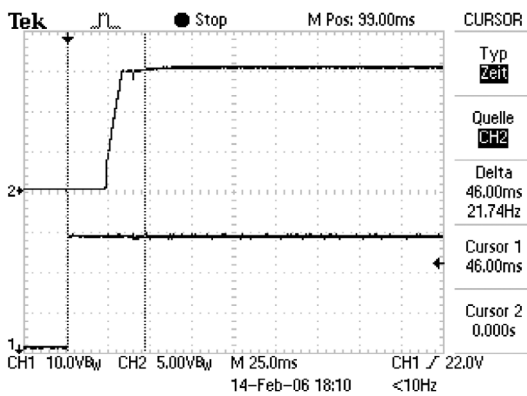

Figure 19. Start up time for MTC3028S15 with full resistive load - 46 ms

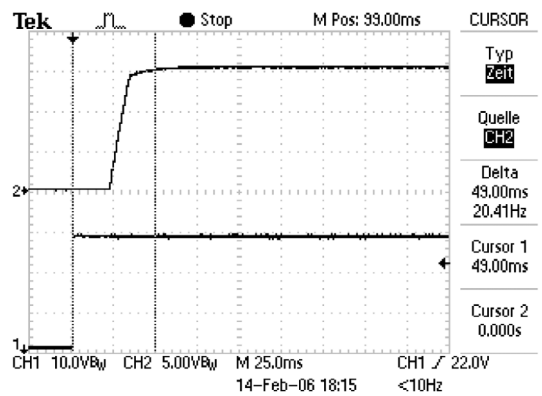
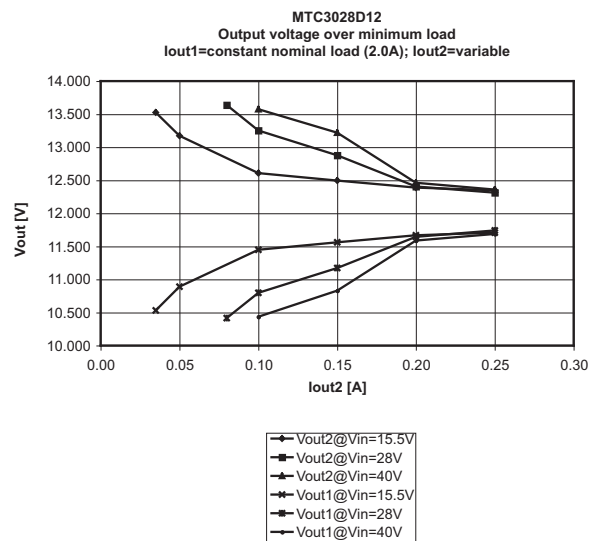
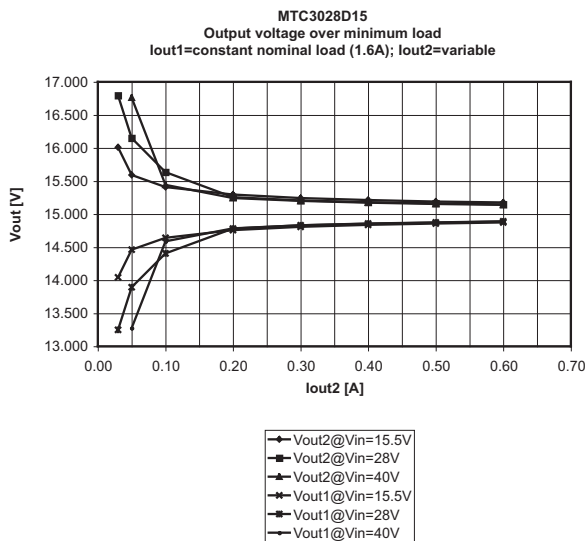
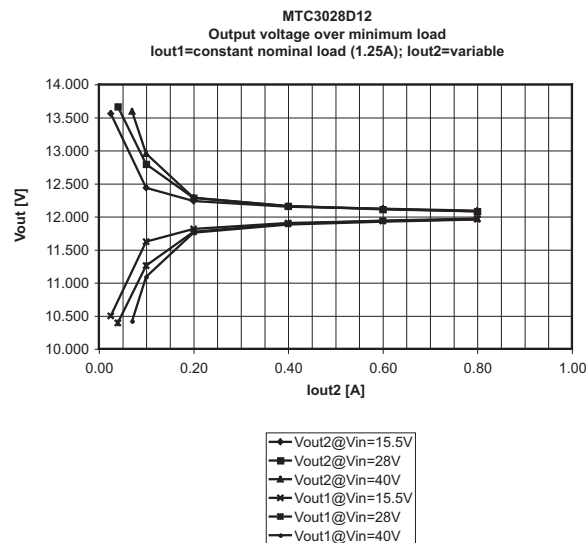
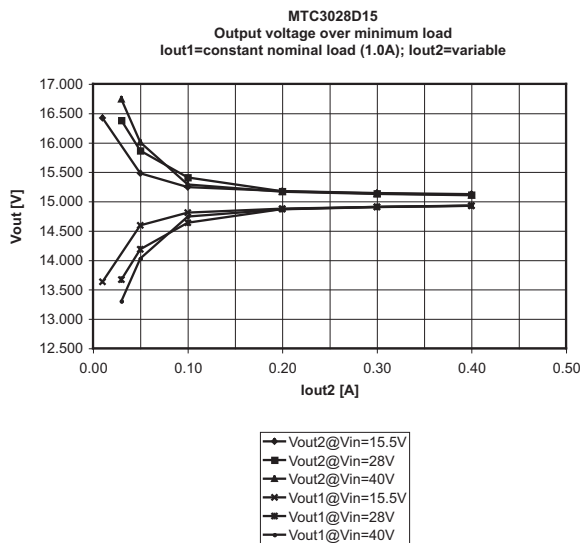
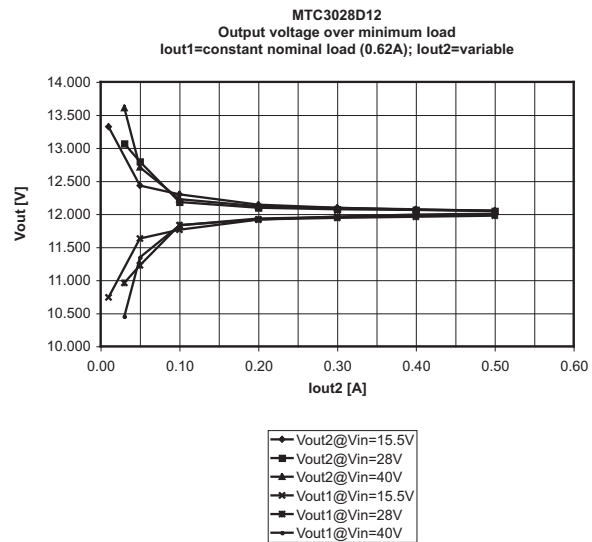
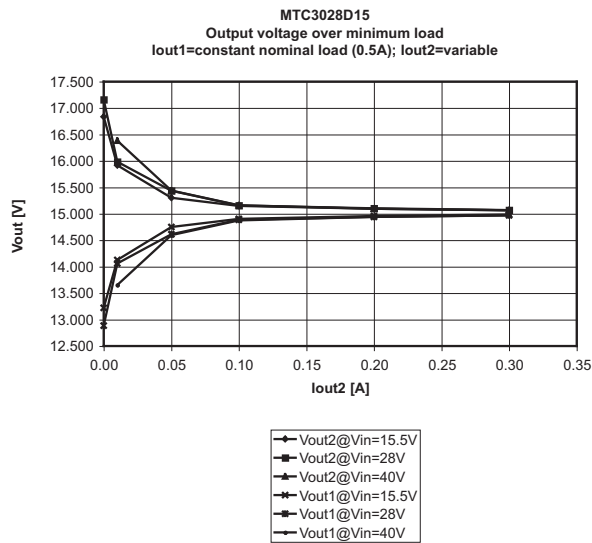
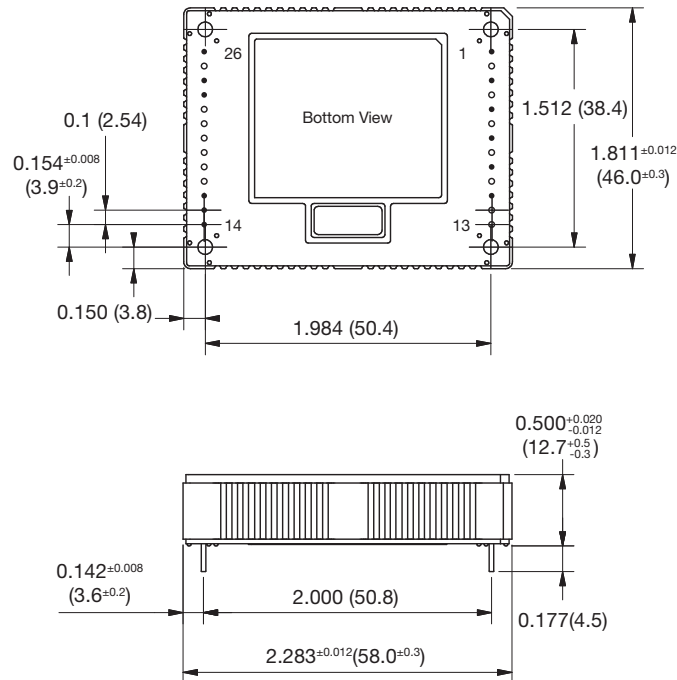

Figure 20. Start up time for MTC3028S15 at full load and 700 µF - 47 ms

Dual Output Cross Regulation



Mechanical Details



MTC30 Connections		
Pin	Single Output	Dual Output
1	No Pin	No Pin
2	Case	Case
3	No Pin	No Pin
4	- Vin	- Vin
5	No Pin	No Pin
6	+ Vin	+ Vin
7	No Pin	No Pin
8	Synchronisation	Synchronisation
9	No Pin	No Pin
10	Inhibit	Inhibit
11	No Pin	No Pin
12	Thermal Warning (TW)	Thermal Warning (TW)
13	Signal GND (SGND)	No Pin
14	No Pin	No Pin
15	No Pin	No Pin
16	No Pin	No Pin
17	Adjust	No Pin
18	+ Sense	No Pin
19	+ Vout	+ Vout
20	+ Vout	+ Vout
21	- Vout (COM)	COM
22	- Vout (COM)	COM
23	No Pin	- Vout
24	No Pin	- Vout
25	- Sense	No Pin
26	No Pin	No Pin

Notes.

- Dimensions are in inches (mm)
- Tolerance: ± 0.02 inches (± 0.5 mm)
- Weight: 0.15 lb (70 g)
- Materials & Finish:
 - Pin - Diameter: 0.032 (0.8)
Material: Cu Zn30 2.5 μ m Ni
Finish: 0.2-0.5 μ m AU (HV 170-200)
 - Mounting Hole - Diameter: 0.102 (2.6)
 - Case - Material: Aluminium (Al Mg Si 0.5)
Finish: Chromated
 - Nameplate - Non-conductive plastic

Soldering.

- Wave soldering: 260 °C max for 10 s
Soldering gun: 450 °C max for 5 s