

MSP430F525x Mixed Signal Microcontroller

FEATURES

- **Dual-Supply Voltage Device**
 - Primary Supply (AVCC, DVCC)
 - Powered From External Supply: 3.6 V Down to 1.8 V
 - Up to 18 General-Purpose I/Os With up to Eight External Interrupts
 - Low-Voltage Interface Supply (DVIO)
 - Powered From Separate External Supply: 1.62 V to 1.98 V
 - Up to 35 General-Purpose I/Os With up to Sixteen External Interrupts
 - Serial Communications
- **Ultralow-Power Consumption**
 - Active Mode (AM): All System Clocks Active
290 μ A/MHz at 8 MHz, 3.0 V, Flash Program Execution (Typical)
150 μ A/MHz at 8 MHz, 3.0 V, RAM Program Execution (Typical)
 - Standby Mode (LPM3): Real-Time Clock With Crystal, Watchdog, and Supply Supervisor Operational, Full RAM Retention, Fast Wake-Up:
2.1 μ A at 2.2 V, 2.3 μ A at 3.0 V (Typical)
Low-Power Oscillator (VLO), General-Purpose Counter, Watchdog, and Supply Supervisor Operational, Full RAM Retention, Fast Wake-Up:
1.6 μ A at 3.0 V (Typical)
 - Off Mode (LPM4): Full RAM Retention, Supply Supervisor Operational, Fast Wake-Up:
1.3 μ A at 3.0 V (Typical)
 - Shutdown Mode (LPM4.5): 0.18 μ A at 3.0 V (Typical)
- **Wake Up From Standby Mode in 3.5 μ s (Typical)**
- **16-Bit RISC Architecture, Extended Memory, Up to 25-MHz System Clock**
- **Flexible Power Management System**
 - Fully Integrated LDO With Programmable Regulated Core Supply Voltage
 - Supply Voltage Supervision, Monitoring, and Brownout
- **Unified Clock System**
 - FLL Control Loop for Frequency Stabilization
 - Low-Power Low-Frequency Internal Clock Source (VLO)
 - Low-Frequency Trimmed Internal Reference Source (REFO)
 - 32-kHz Watch Crystals (XT1)
 - HF Crystals up to 32 MHz (XT2)
- **16-Bit Timer TA0, Timer_A With Five Capture/Compare Registers**
- **16-Bit Timer TA1, Timer_A With Three Capture/Compare Registers**
- **16-Bit Timer TA2, Timer_A With Three Capture/Compare Registers**
- **16-Bit Timer TB0, Timer_B With Seven Capture/Compare Shadow Registers**
- **Four Universal Serial Communication Interfaces**
 - USCI_A0, A1, A2, A3 Each Support:
 - Enhanced UART With Auto-Baudrate Detection
 - IrDA Encoder and Decoder
 - Synchronous SPI
 - USCI_B0, B1, B2, B3 Each Support:
 - I²C
 - Synchronous SPI
- **10-Bit Analog-to-Digital Converter (ADC) With Internal Reference, Sample-and-Hold**
- **Comparator**
- **Hardware Multiplier Supports 32-Bit Operations**
- **Serial Onboard Programming, No External Programming Voltage Needed**
- **Three-Channel Internal DMA**
- **Basic Timer With Real-Time Clock Feature**



Please be aware that an important notice concerning availability, standard warranty, and use in critical applications of Texas Instruments semiconductor products and disclaimers thereto appears at the end of this data sheet.

MSP430, Code Composer Studio are trademarks of Texas Instruments.

- Family Members are Summarized in [Table 1](#)
- For Complete Module Descriptions, See the *MSP430x5xx and MSP430x6xx Family User's Guide (SLAU208)*
- For Design Guidelines, See *Designing With MSP430F522x and MSP430F521x Devices (SLAA558)*

APPLICATIONS

- "Always On" System Controllers
- Power-Management Hubs
- Bluetooth Controllers
- Analog and Digital Sensor Fusion Systems
- Data Loggers
- General-Purpose Applications

DESCRIPTION

Using an "always on" ultralow-power system controller can significantly reduce power consumption on portable devices like handsets and tablets. These controllers can act as sensor hubs and monitor user stimuli (for example, reading inertial sensors or touch sensors) and vital system parameters like battery health and temperature, while power-hungry application processors and touch screen controllers are turned off. The microcontroller can then "wake up" the system based on a user input or on a fault condition that requires CPU intervention.

The MSP430F525x series is the latest addition to the 1.8-V split-rail I/O portfolio (previously only available on MSP430F522x) and is specifically designed for "always on" system controller applications. 1.8-V I/O allows for seamless interface to application processors and other devices without the need for external level translation, while the primary supply to the MCU can be on a higher voltage rail.

Compared to the MSP430F522x, the MSP430F525x provides up to four times more RAM (32KB) and double the serial interfaces (four USCI_A and four USCI_B). The MSP430F525x also features four 16-bit timers, a high-performance 10-bit analog-to-digital converter (ADC), a hardware multiplier, DMA, a comparator, and a real-time clock module with alarm capabilities. The MSP430F525x consumes 290 $\mu\text{A}/\text{MHz}$ (typical) in active mode running from flash memory, and it consumes 1.6 μA (typical) in standby mode (LPM3). The MSP430F525x can switch to active mode in 3.5 μs (typical), which makes it a great fit for always-on low-power applications.

Key benefits of the MSP430F525x are as follows:

- Up to 32KB RAM allows complex sensor hub algorithms and high levels of aggregation such as keyboard control and power management.
- Four USCI_A and four USCI_B allow for eight concurrent dedicated hardware serial interfaces (for example, four I2C and four SPI) for fast and robust communication to sensors or peripheral devices.
- Up to 35 I/Os that can be used in the 1.8-V voltage rail.

Typical applications include analog and digital sensor fusion systems, data loggers, and various general-purpose applications.

[Table 1](#) summarizes the available family members.

Table 1. Family Members⁽¹⁾⁽²⁾

Device	Flash (KB)	SRAM (KB)	Timer_A ⁽³⁾	Timer_B ⁽⁴⁾	USCI		ADC10_A (Ch)	Comp_B (Ch)	I/O DVCC ⁽⁵⁾	I/O DVIO ⁽⁶⁾	BSL Type	Package Type
					Channel A: UART, IrDA, SPI	Channel B: SPI, I ² C						
MSP430F5259	128	32	5, 3, 3	7	4	4	10 ext, 2 int	8	18	35	I ² C	64 RGC 64 YFF ⁽⁷⁾ 80 ZQE
MSP430F5258	128	32	5, 3, 3	7	4	4	N/A	8	18	35	I ² C	64 RGC 80 ZQE
MSP430F5257	128	16	5, 3, 3	7	4	4	10 ext, 2 int	8	18	35	I ² C	64 RGC 80 ZQE
MSP430F5256	128	16	5, 3, 3	7	4	4	N/A	8	18	35	I ² C	64 RGC 80 ZQE
MSP430F5255	128	32	5, 3, 3	7	4	4	10 ext, 2 int	8	18	35	UART	64 RGC 80 ZQE
MSP430F5254	128	32	5, 3, 3	7	4	4	N/A	8	18	35	UART	64 RGC 80 ZQE
MSP430F5253	128	16	5, 3, 3	7	4	4	10 ext, 2 int	8	18	35	UART	64 RGC 80 ZQE
MSP430F5252	128	16	5, 3, 3	7	4	4	N/A	8	18	35	UART	64 RGC 80 ZQE

- (1) For the most current package and ordering information, see the Package Option Addendum at the end of this document, or see the TI web site at www.ti.com.
- (2) Package drawings, standard packing quantities, thermal data, symbolization, and PCB design guidelines are available at www.ti.com/packaging.
- (3) Each number in the sequence represents an instantiation of Timer_A with its associated number of capture compare registers and PWM output generators available. For example, a number sequence of 3, 5 would represent two instantiations of Timer_A, the first instantiation having 3 and the second instantiation having 5 capture compare registers and PWM output generators, respectively.
- (4) Each number in the sequence represents an instantiation of Timer_B with its associated number of capture compare registers and PWM output generators available. For example, a number sequence of 3, 5 would represent two instantiations of Timer_B, the first instantiation having 3 and the second instantiation having 5 capture compare registers and PWM output generators, respectively.
- (5) All of these I/O reside on a single voltage rail supplied by DVCC.
- (6) All of these I/O reside on a single voltage rail supplied by DVIO.
- (7) Product Preview

Functional Block Diagram

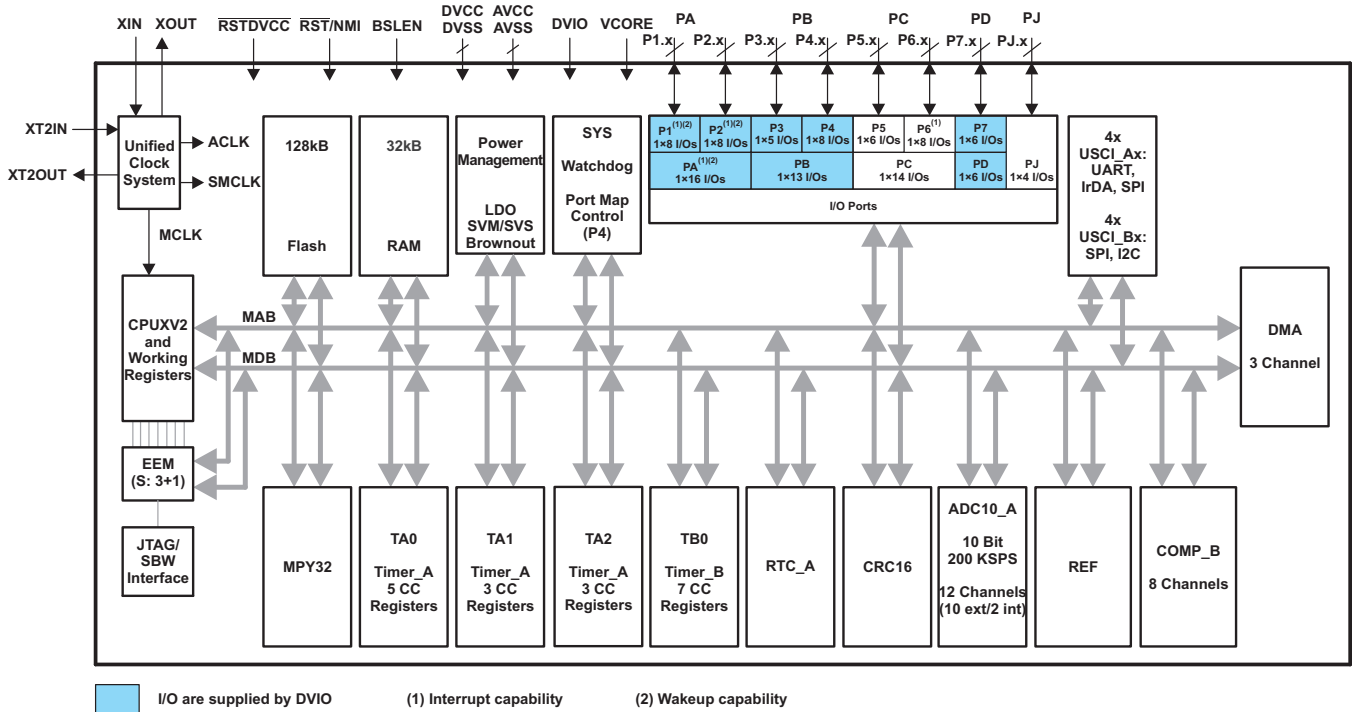

PRODUCT PREVIEW

Pin Designation – RGC Package

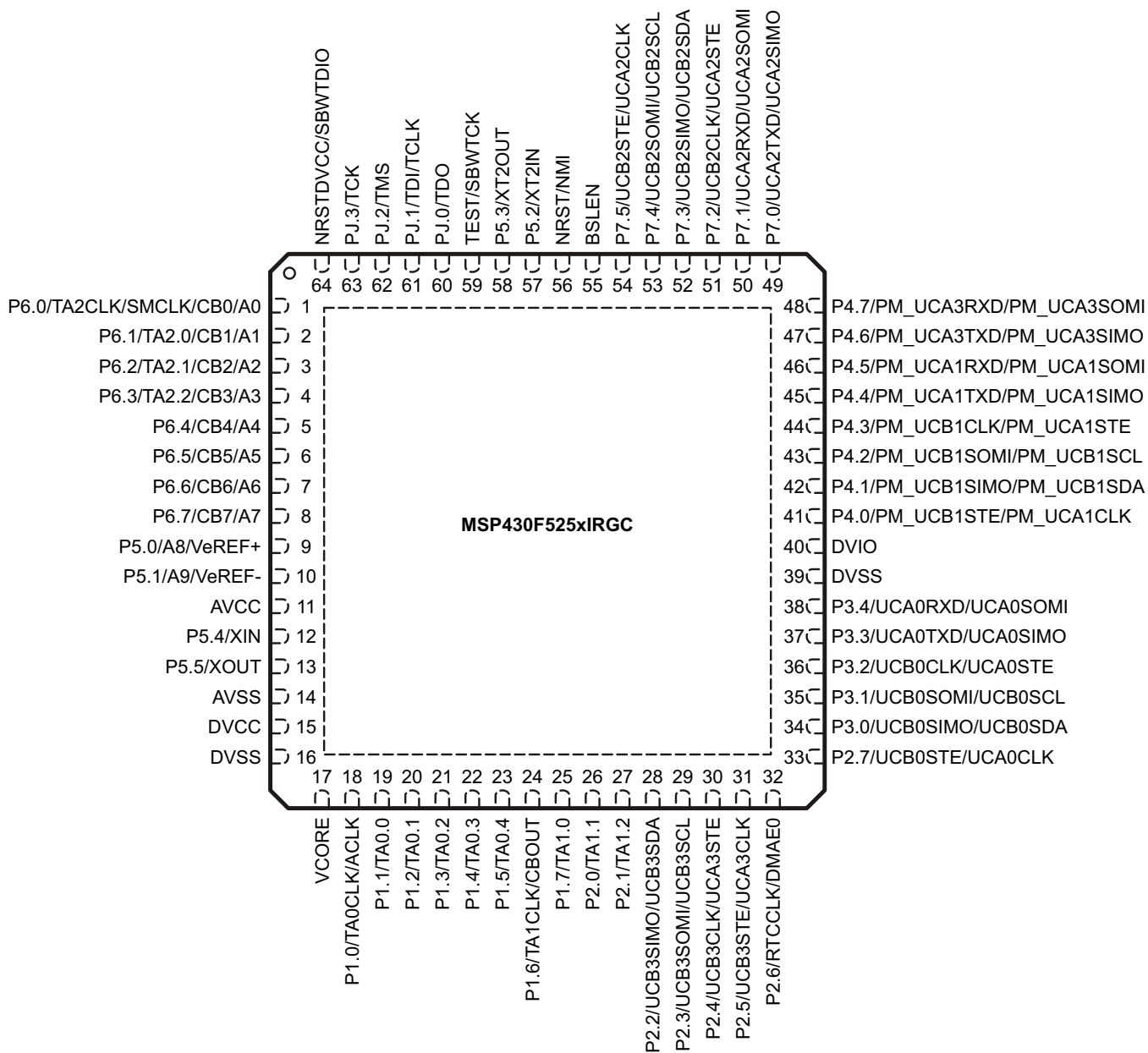

PRODUCT PREVIEW

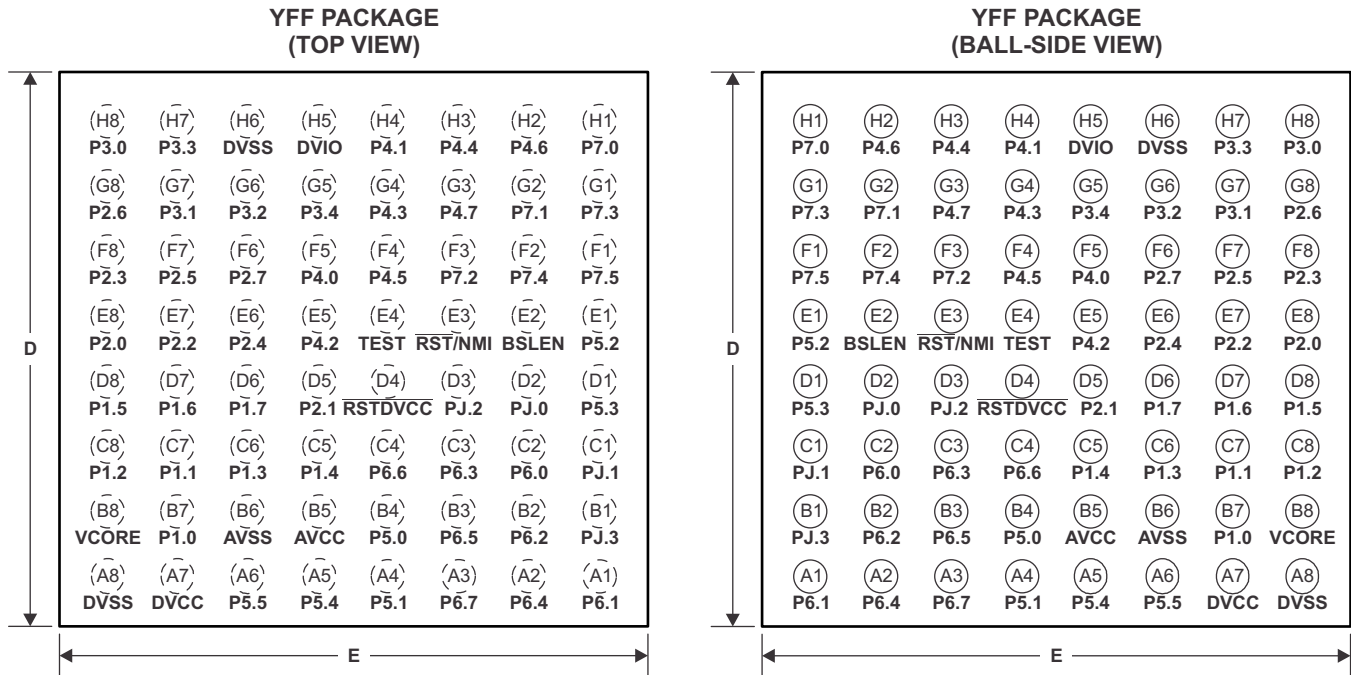
Pin Designation – YFF Package

Package Dimensions: The package dimensions for the YFF package are shown in [Table 2](#). See the package drawing at the end of this data sheet for more details.

Table 2. YFF Package Dimensions

PACKAGED DEVICES	D	E
MSP430F5259IYFF	3.415 ± 0.03	3.535 ± 0.03

Table 3. Terminal Functions

TERMINAL				I/O ⁽¹⁾	DESCRIPTION
NAME	NO.				
	RGC	ZQE	YFF		
P6.4/CB4/A4	5	C1	A2	I/O	General-purpose digital I/O with port interrupt Comparator_B input CB4 Analog input A4 – ADC (not available on all device types)
P6.5/CB5/A5	6	D2	B3	I/O	General-purpose digital I/O with port interrupt Comparator_B input CB5 Analog input A5 – ADC (not available on all device types)
P6.6/CB6/A6	7	D1	C4	I/O	General-purpose digital I/O with port interrupt Comparator_B input CB6 Analog input A6 – ADC (not available on all device types)
P6.7/CB7/A7	8	D3	A3	I/O	General-purpose digital I/O with port interrupt Comparator_B input CB7 Analog input A7 – ADC (not available on all device types)
P5.0/A8/VeREF+	9	E1	B4	I/O	General-purpose digital I/O Analog input A8 – ADC (not available on all device types) Input for an external reference voltage to the ADC (not available on all device types)
P5.1/A9/VeREF-	10	E2	A4	I/O	General-purpose digital I/O Analog input A9 – ADC (not available on all device types) Negative terminal for the ADC's reference voltage for an external applied reference voltage (not available on all device types)
AVCC	11	F2	B5		Analog power supply
P5.4/XIN	12	F1	A5	I/O	General-purpose digital I/O Input terminal for crystal oscillator XT1 ⁽²⁾
P5.5/XOUT	13	G1	A6	I/O	General-purpose digital I/O Output terminal of crystal oscillator XT1
AVSS	14	G2	B6		Analog ground supply
DVCC	15	H1	A7		Digital power supply
DVSS	16	J1	A8		Digital ground supply
VCORE ⁽³⁾	17	J2	B8		Regulated core power supply output (internal use only, no external current loading)
P1.0/TA0CLK/ACLK ⁽⁴⁾	18	H2	B7	I/O	General-purpose digital I/O with port interrupt TA0 clock signal TA0CLK input ACLK output (divided by 1, 2, 4, 8, 16, or 32)
P1.1/TA0.0 ⁽⁴⁾	19	H3	C7	I/O	General-purpose digital I/O with port interrupt TA0 CCR0 capture: CCI0A input, compare: Out0 output
P1.2/TA0.1 ⁽⁴⁾	20	J3	C8	I/O	General-purpose digital I/O with port interrupt TA0 CCR1 capture: CCI1A input, compare: Out1 output
P1.3/TA0.2 ⁽⁴⁾	21	G4	C6	I/O	General-purpose digital I/O with port interrupt TA0 CCR2 capture: CCI2A input, compare: Out2 output

(1) I = input, O = output, N/A = not available

(2) When in crystal bypass mode, XIN can be configured so that it can support an input digital waveform with swing levels from DVSS to DVCC or DVSS to DVIO. In this case, it is required that the pin be configured properly for the intended input swing.

(3) V_{CORE} is for internal use only. No external current loading is possible. V_{CORE} should only be connected to the recommended capacitor value, C_{V_{CORE}}.

(4) This pin function is supplied by DVIO. See [Electrical Characteristics](#) for input and output requirements.

Table 3. Terminal Functions (continued)

TERMINAL				I/O ⁽¹⁾	DESCRIPTION
NAME	NO.				
	RGC	ZQE	YFF		
P1.4/TA0.3 ⁽⁴⁾	22	H4	C5	I/O	General-purpose digital I/O with port interrupt TA0 CCR3 capture: CCI3A input compare: Out3 output
P1.5/TA0.4 ⁽⁴⁾	23	J4	D8	I/O	General-purpose digital I/O with port interrupt TA0 CCR4 capture: CCI4A input, compare: Out4 output
P1.6/TA1CLK/CBOUT ⁽⁴⁾	24	G5	D7	I/O	General-purpose digital I/O with port interrupt TA1 clock signal TA1CLK input Comparator_B output
P1.7/TA1.0 ⁽⁴⁾	25	H5	D6	I/O	General-purpose digital I/O with port interrupt TA1 CCR0 capture: CCI0A input, compare: Out0 output
P2.0/TA1.1 ⁽⁴⁾	26	J5	E8	I/O	General-purpose digital I/O with port interrupt TA1 CCR1 capture: CCI1A input, compare: Out1 output
P2.1/TA1.2 ⁽⁴⁾	27	G6	D5	I/O	General-purpose digital I/O with port interrupt TA1 CCR2 capture: CCI2A input, compare: Out2 output
P2.2/UCB3SIMO/UCB3SDA ⁽⁴⁾	28	J6	E7	I/O	General-purpose digital I/O with port interrupt Slave in, master out – USCI_B3 SPI mode I2C data – USCI_B3 I2C mode
P2.3/UCB3SOMI/UCB3SCL ⁽⁵⁾	29	H6	F8	I/O	General-purpose digital I/O with port interrupt Clock signal input – USCI_B3 SPI slave mode Clock signal output – USCI_B3 SPI master mode Slave transmit enable – USCI_A3 SPI mode
P2.4/UCB3CLK/UCA3STE ⁽⁵⁾	30	J7	E6	I/O	General-purpose digital I/O with port interrupt Clock signal input – USCI_B3 SPI slave mode Clock signal output – USCI_B3 SPI master mode Slave transmit enable – USCI_A3 SPI mode
P2.5/UCB3STE/UCA3CLK ⁽⁵⁾	31	J8	F7	I/O	General-purpose digital I/O with port interrupt Slave transmit enable – USCI_B3 SPI mode Clock signal input – USCI_A3 SPI slave mode Clock signal output – USCI_A3 SPI master mode
P2.6/RTCCLK/DMAE0 ⁽⁵⁾	32	J9	G8	I/O	General-purpose digital I/O with port interrupt RTC clock output for calibration DMA external trigger input
P2.7/UCB0STE/UCA0CLK ⁽⁵⁾	33	H7	F6	I/O	General-purpose digital I/O Slave transmit enable – USCI_B0 SPI mode Clock signal input – USCI_A0 SPI slave mode Clock signal output – USCI_A0 SPI master mode
P3.0/UCB0SIMO/UCB0SDA ⁽⁵⁾	34	H8	H8	I/O	General-purpose digital I/O Slave in, master out – USCI_B0 SPI mode I2C data – USCI_B0 I2C mode
P3.1/UCB0SOMI/UCB0SCL ⁽⁵⁾	35	H9	G7	I/O	General-purpose digital I/O Slave out, master in – USCI_B0 SPI mode I2C clock – USCI_B0 I2C mode

(5) This pin function is supplied by DVIO. See [Electrical Characteristics](#) for input and output requirements.

Table 3. Terminal Functions (continued)

TERMINAL				I/O ⁽¹⁾	DESCRIPTION
NAME	NO.				
	RGC	ZQE	YFF		
P3.2/UCB0CLK/UCA0STE ⁽⁵⁾	36	G8	G6	I/O	General-purpose digital I/O Clock signal input – USCI_B0 SPI slave mode Clock signal output – USCI_B0 SPI master mode Slave transmit enable – USCI_A0 SPI mode
P3.3/UCA0TXD/UCA0SIMO ⁽⁵⁾	37	G9	H7	I/O	General-purpose digital I/O Transmit data – USCI_A0 UART mode Slave in, master out – USCI_A0 SPI mode
P3.4/UCA0RXD/UCA0SOMI ⁽⁵⁾	38	G7	G5	I/O	General-purpose digital I/O Receive data – USCI_A0 UART mode Slave out, master in – USCI_A0 SPI mode
DVSS	39	F9	H6		Digital ground supply
DVIO ⁽⁶⁾	40	E9	H5		Digital I/O power supply
P4.0/PM_UCB1STE/ PM_UCA1CLK ⁽⁵⁾	41	E8	F5	I/O	General-purpose digital I/O with reconfigurable port mapping secondary function Default mapping: Slave transmit enable – USCI_B1 SPI mode Default mapping: Clock signal input – USCI_A1 SPI slave mode Default mapping: Clock signal output – USCI_A1 SPI master mode
P4.1/PM_UCB1SIMO/ PM_UCB1SDA ⁽⁵⁾	42	E7	H4	I/O	General-purpose digital I/O with reconfigurable port mapping secondary function Default mapping: Slave in, master out – USCI_B1 SPI mode Default mapping: I2C data – USCI_B1 I2C mode
P4.2/PM_UCB1SOMI/ PM_UCB1SCL ⁽⁷⁾	43	D9	E5	I/O	General-purpose digital I/O with reconfigurable port mapping secondary function Default mapping: Slave out, master in – USCI_B1 SPI mode Default mapping: I2C clock – USCI_B1 I2C mode
P4.3/PM_UCB1CLK/ PM_UCA1STE ⁽⁷⁾	44	D8	G4	I/O	General-purpose digital I/O with reconfigurable port mapping secondary function Default mapping: Clock signal input – USCI_B1 SPI slave mode Default mapping: Clock signal output – USCI_B1 SPI master mode Default mapping: Slave transmit enable – USCI_A1 SPI mode
P4.4/PM_UCA1TXD/ PM_UCA1SIMO ⁽⁷⁾	45	D7	H3	I/O	General-purpose digital I/O with reconfigurable port mapping secondary function Default mapping: Transmit data – USCI_A1 UART mode Default mapping: Slave in, master out – USCI_A1 SPI mode
P4.5/PM_UCA1RXD/ PM_UCA1SOMI ⁽⁷⁾	46	C9	F4	I/O	General-purpose digital I/O with reconfigurable port mapping secondary function Default mapping: Receive data – USCI_A1 UART mode Default mapping: Slave out, master in – USCI_A1 SPI mode
P4.6/PM_UCA3TXD/ PM_UCA3SIMO ⁽⁷⁾	47	C8	H2	I/O	General-purpose digital I/O with reconfigurable port mapping secondary function Default mapping: Transmit data – USCI_A3 UART mode Default mapping: Slave in, master out – USCI_A3 SPI mode
P4.7/PM_UCA3RXD/ PM_UCA3SOMI ⁽⁷⁾	48	C7	G3	I/O	General-purpose digital I/O with reconfigurable port mapping secondary function Default mapping: Receive data – USCI_A3 UART mode Default mapping: Slave out, master in – USCI_A3 SPI mode

(6) The voltage on DVIO is not supervised or monitored.

(7) This pin function is supplied by DVIO. See [Electrical Characteristics](#) for input and output requirements.

Table 3. Terminal Functions (continued)

TERMINAL				I/O ⁽¹⁾	DESCRIPTION
NAME	NO.				
	RGC	ZQE	YFF		
P7.0/UCA2TXD/UCA2SIMO ⁽⁷⁾	49	B8, B9	H1	I/O	General-purpose digital I/O Transmit data – USCI_A2 UART mode Slave in, master out – USCI_A2 SPI mode
P7.1/UCA2RXD/UCA2SOMI ⁽⁷⁾	50	A9	G2	I/O	General-purpose digital I/O Receive data – USCI_A2 UART mode Slave out, master in – USCI_A2 SPI mode
P7.2/UCB2CLK/UCA2STE ⁽⁷⁾	51	B7	F3	I/O	General-purpose digital I/O Clock signal input – USCI_B2 SPI slave mode Clock signal output – USCI_B2 SPI master mode Slave transmit enable – USCI_A2 SPI mode
P7.3/UCB2SIMO/UCB2SDA ⁽⁷⁾	52	A8	G1	I/O	General-purpose digital I/O Slave in, master out – USCI_B2 SPI mode I2C data – USCI_B2 I2C mode
P7.4/UCB2SOMI/UCB2SCL ⁽⁷⁾	53	A7	F2	I/O	General-purpose digital I/O Slave out, master in – USCI_B2 SPI mode I2C clock – USCI_B2 I2C mode
P7.5/UCB2STE/UCA2CLK ⁽⁸⁾	54	A6	F1	I/O	General-purpose digital I/O Slave transmit enable – USCI_B2 SPI mode Clock signal input – USCI_A2 SPI slave mode Clock signal output – USCI_A2 SPI master mode
BSLEN ⁽⁸⁾	55	B6	E2	I	BSL enable with internal pulldown
$\overline{\text{RST}}/\text{NMI}$ ⁽⁸⁾	56	A5	E3	I	Reset input active low ⁽⁹⁾⁽¹⁰⁾ Non-maskable interrupt input ⁽⁹⁾
P5.2/XT2IN	57	B5	E1	I/O	General-purpose digital I/O Input terminal for crystal oscillator XT2 ⁽¹¹⁾
P5.3/XT2OUT	58	B4	D1	I/O	General-purpose digital I/O Output terminal of crystal oscillator XT2
TEST/SBWTCK ⁽¹²⁾	59	A4	E4	I	Test mode pin – Selects four wire JTAG operation Spy-Bi-Wire input clock when Spy-Bi-Wire operation activated
PJ.0/TDO ⁽¹³⁾	60	C5	D2	I/O	General-purpose digital I/O JTAG test data output port
PJ.1/TDI/TCLK ⁽¹³⁾	61	C4	C1	I/O	General-purpose digital I/O JTAG test data input or test clock input
PJ.2/TMS ⁽¹³⁾	62	A3	D3	I/O	General-purpose digital I/O JTAG test mode select
PJ.3/TCK ⁽¹³⁾	63	B3	B1	I/O	General-purpose digital I/O JTAG test clock

(8) This pin function is supplied by DVIO. See [Electrical Characteristics](#) for input and output requirements.

(9) This pin is configurable as reset or NMI and resides on the DVIO supply domain. When driven from external, the input swing levels from DVSS to DVIO are required.

(10) When this pin is configured as reset, the internal pullup resistor is enabled by default.

(11) When in crystal bypass mode, XT2IN can be configured so that it can support an input digital waveform with swing levels from DVSS to DVCC or DVSS to DVIO. In this case, it is required that the pin be configured properly for the intended input swing.

(12) See [Bootstrap Loader - I2C](#) and [JTAG Operation](#) for use with BSL and JTAG functions.

(13) See [JTAG Operation](#) for use with JTAG function.

Table 3. Terminal Functions (continued)

TERMINAL				I/O ⁽¹⁾	DESCRIPTION
NAME	NO.				
	RGC	ZQE	YFF		
$\overline{\text{RSTDVCC}}/\text{SBWTDIO}^{(13)}$	64	A2	D4	I/O	Reset input active low ⁽¹⁴⁾ Spy-Bi-Wire data input/output when Spy-Bi-Wire operation activated
P6.0/TA2CLK/SMCLK/CB0/A0	1	A1	C2	I/O	General-purpose digital I/O with port interrupt TA2 clock signal TA2CLK input SMCLK output Comparator_B input CB0 Analog input A0 – ADC (not available on all device types)
P6.1/TA2.0/CB1/A1	2	B2	A1	I/O	General-purpose digital I/O with port interrupt TA2 CCR0 capture: CCI0A input, compare: Out0 output Comparator_B input CB1 Analog input A1 – ADC (not available on all device types) BSL transmit output
P6.2/TA2.1/CB2/A2	3	B1	B2	I/O	General-purpose digital I/O with port interrupt TA2 CCR1 capture: CCI1A input, compare: Out1 output Comparator_B input CB2 Analog input A2 – ADC (not available on all device types) BSL receive input
P6.3/TA2.2/CB3/A3	4	C2	C3	I/O	General-purpose digital I/O with port interrupt TA2 CCR2 capture: CCI2A input, compare: Out2 output Comparator_B input CB3 Analog input A3 – ADC (not available on all device types)
Reserved	N/A	⁽¹⁵⁾	N/A		Reserved
QFN Pad	Pad	N/A	N/A		QFN package pad. Connection to V _{SS} recommended.

(14) This non-configurable reset resides on the DVCC supply domain and has an internal pullup to DVCC. When driven from external, input swing levels from DVSS to DVCC are required. This reset must be used for Spy-Bi-Wire communication and is not the same $\overline{\text{RST}}/\text{MNI}$ reset as found on other devices in the MSP430 family. Refer to [Bootstrap Loader - I2C](#) and [JTAG Operation](#) for details regarding the use of this pin.

(15) C6, D4, D5, D6, E3, E4, E5, E6, F3, F4, F5, F6, F7, F8, G3 are reserved and should be connected to ground.

Development Tools Support

All MSP430™ microcontrollers are supported by a wide variety of software and hardware development tools. Tools are available from TI and various third parties. See them all at www.ti.com/msp430tools.

Hardware Features

See the *Code Composer Studio for MSP430 User's Guide (SLAU157)* for details on the available features.

MSP430 Architecture	4-Wire JTAG	2-Wire JTAG	Break-points (N)	Range Break-points	Clock Control	State Sequencer	Trace Buffer	LPMx.5 Debugging Support
MSP430Xv2	Yes	Yes	8	Yes	Yes	Yes	Yes	No

Recommended Hardware Options

Target Socket Boards

The target socket boards allow easy programming and debugging of the device using JTAG. They also feature header pin outs for prototyping. Target socket boards can be ordered individually or as a kit with the JTAG programmer and debugger included. The following table shows the compatible target boards and the supported packages.

Package	Target Board and Programmer Bundle	Target Board Only
64-pin RCG (QFN)	MSP-FET430U64C	MSP-TS430RGC64C

Experimenter Boards

Experimenter boards and evaluation kits are available for some MSP430 devices. These kits feature additional hardware components and connectivity for full system evaluation and prototyping. See www.ti.com/msp430tools for details.

Debugging and Programming Tools

Hardware programming and debugging tools are available from TI and from its third party suppliers. See the full list of available tools at www.ti.com/msp430tools.

Production Programmers

The production programmers expedite loading firmware to devices by programming several devices simultaneously.

Part Number	PC Port	Features	Provider
MSP-GANG	Serial and USB	Program up to eight devices at a time. Works with PC or standalone.	Texas Instruments

Recommended Software Options

Integrated Development Environments

Software development tools are available from TI or from third parties. Open source solutions are also available. This device is supported by Code Composer Studio™ IDE (CCS).

MSP430Ware

[MSP430Ware](#) is a collection of code examples, data sheets, and other design resources for all MSP430 devices delivered in a convenient package. In addition to providing a complete collection of existing MSP430 design resources, MSP430Ware also includes a high-level API called MSP430 Driver Library. This library makes it easy to program MSP430 hardware. MSP430Ware is available as a component of CCS or as a standalone package.

SYS/BIOS

SYS/BIOS is an advanced real-time operating system for the MSP430 microcontrollers. It features preemptive deterministic multi-tasking, hardware abstraction, memory management, and real-time analysis. SYS/BIOS is available free of charge and is provided with full source code.

Command-Line Programmer

MSP430 Flasher is an open-source shell-based interface for programming MSP430 microcontrollers through a FET programmer or eZ430 using JTAG or Spy-Bi-Wire (SBW) communication. MSP430 Flasher can be used to download binary files (.txt or .hex) files directly to the MSP430 without the need for an IDE.

Community Resources

The following links connect to TI community resources. Linked contents are provided "AS IS" by the respective contributors. They do not constitute TI specifications and do not necessarily reflect TI's views; see TI's [Terms of Use](#).

TI E2E Community

TI's Engineer-to-Engineer (E2E) Community. Created to foster collaboration among engineers. At e2e.ti.com, you can ask questions, share knowledge, explore ideas, and help solve problems with fellow engineers.

TI Embedded Processors Wiki

Texas Instruments Embedded Processors Wiki. Established to help developers get started with embedded processors from Texas Instruments and to foster innovation and growth of general knowledge about the hardware and software surrounding these devices.

Device and Development Tool Nomenclature

To designate the stages in the product development cycle, TI assigns prefixes to the part numbers of all MSP430™ MCU devices and support tools. Each MSP430™ MCU commercial family member has one of two prefixes: MSP or XMS (for example, MSP430F5259). Texas Instruments recommends two of three possible prefix designators for its support tools: MSP and MSPX. These prefixes represent evolutionary stages of product development from engineering prototypes (with XMS for devices and MSPX for tools) through fully qualified production devices and tools (with MSP for devices and MSP for tools).

Device development evolutionary flow:

XMS – Experimental device that is not necessarily representative of the final device's electrical specifications

MSP – Fully qualified production device

Support tool development evolutionary flow:

MSPX – Development-support product that has not yet completed Texas Instruments internal qualification testing.

MSP – Fully-qualified development-support product

XMS devices and MSPX development-support tools are shipped against the following disclaimer:

"Developmental product is intended for internal evaluation purposes."

MSP devices and MSP development-support tools have been characterized fully, and the quality and reliability of the device have been demonstrated fully. TI's standard warranty applies.

Predictions show that prototype devices (XMS) have a greater failure rate than the standard production devices. Texas Instruments recommends that these devices not be used in any production system because their expected end-use failure rate still is undefined. Only qualified production devices are to be used.

TI device nomenclature also includes a suffix with the device family name. This suffix indicates the package type (for example, PZP) and temperature range (for example, T). [Figure 1](#) provides a legend for reading the complete device name for any family member.

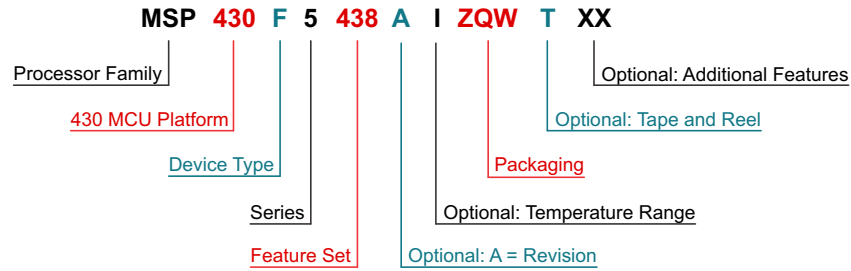
Part Number Decoder

Processor Family	CC = Embedded RF Radio MSP = Mixed Signal Processor XMS = Experimental Silicon	
430 MCU Platform	TI's Low Power Microcontroller Platform	
Device Type	Memory Type C = ROM F = Flash FR = FRAM G = Flash (Value Line) L = No Nonvolatile Memory	Specialized Application AFE = Analog Front End BT = Preprogrammed with Bluetooth BQ = Contactless Power CG = ROM Medical FE = Flash Energy Meter FG = Flash Medical FW = Flash Electronic Flow Meter
Series	1 Series = Up to 8 MHz 2 Series = Up to 16 MHz 3 Series = Legacy 4 Series = Up to 16 MHz w/ LCD	5 Series = Up to 25 MHz 6 Series = Up to 25 MHz w/ LCD 0 = Low Voltage Series
Feature Set	Various Levels of Integration Within a Series	
Optional: A = Revision	N/A	
Optional: Temperature Range	S = 0°C to 50°C C = 0°C to 70°C I = -40°C to 85°C T = -40°C to 105°C	
Packaging	www.ti.com/packaging	
Optional: Tape and Reel	T = Small Reel (7 inch) R = Large Reel (11 inch) No Markings = Tube or Tray	
Optional: Additional Features	*-EP = Enhanced Product (-40°C to 105°C) *-HT = Extreme Temperature Parts (-55°C to 150°C)	

Figure 1. Device Nomenclature

Short-Form Description

CPU ([Link to user's guide](#))

The MSP430 CPU has a 16-bit RISC architecture that is highly transparent to the application. All operations, other than program-flow instructions, are performed as register operations in conjunction with seven addressing modes for source operand and four addressing modes for destination operand.

The CPU is integrated with 16 registers that provide reduced instruction execution time. The register-to-register operation execution time is one cycle of the CPU clock.

Four of the registers, R0 to R3, are dedicated as program counter, stack pointer, status register, and constant generator, respectively. The remaining registers are general-purpose registers.

Peripherals are connected to the CPU using data, address, and control buses and can be handled with all instructions.

The instruction set consists of the original 51 instructions with three formats and seven address modes and additional instructions for the expanded address range. Each instruction can operate on word and byte data.

Program Counter	PC/R0
Stack Pointer	SP/R1
Status Register	SR/CG1/R2
Constant Generator	CG2/R3
General-Purpose Register	R4
General-Purpose Register	R5
General-Purpose Register	R6
General-Purpose Register	R7
General-Purpose Register	R8
General-Purpose Register	R9
General-Purpose Register	R10
General-Purpose Register	R11
General-Purpose Register	R12
General-Purpose Register	R13
General-Purpose Register	R14
General-Purpose Register	R15

Operating Modes

The MSP430 has one active mode and six software selectable low-power modes of operation. An interrupt event can wake up the device from any of the low-power modes, service the request, and restore back to the low-power mode on return from the interrupt program.

The following seven operating modes can be configured by software:

- Active mode (AM)
 - All clocks are active
- Low-power mode 0 (LPM0)
 - CPU is disabled
 - ACLK and SMCLK remain active, MCLK is disabled
 - FLL loop control remains active
- Low-power mode 1 (LPM1)
 - CPU is disabled
 - FLL loop control is disabled
 - ACLK and SMCLK remain active, MCLK is disabled
- Low-power mode 2 (LPM2)
 - CPU is disabled
 - MCLK and FLL loop control and DCOCLK are disabled
 - DCO's dc-generator remains enabled
 - ACLK remains active
- Low-power mode 3 (LPM3)
 - CPU is disabled
 - MCLK, FLL loop control, and DCOCLK are disabled
 - DCO's dc generator is disabled
 - ACLK remains active
- Low-power mode 4 (LPM4)
 - CPU is disabled
 - ACLK is disabled
 - MCLK, FLL loop control, and DCOCLK are disabled
 - DCO's dc generator is disabled
 - Crystal oscillator is stopped
 - Complete data retention
- Low-power mode 4.5 (LPM4.5)
 - Internal regulator disabled
 - No data retention
 - Wakeup from $\overline{\text{RST}}$ /NMI, P1, and P2

Interrupt Vector Addresses

The interrupt vectors and the power-up start address are located in the address range 0FFFFh to 0FF80h. The vector contains the 16-bit address of the appropriate interrupt-handler instruction sequence.

Table 4. Interrupt Sources, Flags, and Vectors

INTERRUPT SOURCE	INTERRUPT FLAG	SYSTEM INTERRUPT	WORD ADDRESS	PRIORITY
System Reset Power-Up External Reset Watchdog Timeout, Password Violation Flash Memory Password Violation PMM Password Violation	WDTIFG, KEYV (SYSRSTIV) ^{(1) (2)}	Reset	0FFFEh	63, highest
System NMI PMM Vacant Memory Access JTAG Mailbox	SVMLIFG, SVMHIFG, DLYLIFG, DLYHIFG, VLRLIFG, VLRHIFG, VMAIFG, JMBNIFG, JMBOUTIFG (SYSSNIV) ⁽¹⁾	(Non)maskable	0FFFCh	62
User NMI NMI Oscillator Fault Flash Memory Access Violation	NMIIFG, OFIFG, ACCVIFG, BUSIFG (SYSUNIV) ^{(1) (2)}	(Non)maskable	0FFFAh	61
COMP_B	Comparator B interrupt flags (CBIV) ^{(1) (3)}	Maskable	0FFF8h	60
USCI_A0 Receive or Transmit	UCA0RXIFG, UCA0TXIFG (UCA0IV) ^{(1) (3)}	Maskable	0FFF6h	59
USCI_B0 Receive or Transmit	UCB0RXIFG, UCB0TXIFG (UCB0IV) ^{(1) (3)}	Maskable	0FFF4h	58
Watchdog Timer_A Interval Timer Mode	WDTIFG	Maskable	0FFF2h	57
USCI_A1 Receive or Transmit	UCA1RXIFG, UCA1TXIFG (UCA1IV) ^{(1) (3)}	Maskable	0FFF0h	56
USCI_B1 Receive or Transmit	UCB1RXIFG, UCB1TXIFG (UCB1IV) ^{(1) (3)}	Maskable	0FFEEh	55
ADC10_A	ADC10IFG0 ^{(1) (3) (4)}	Maskable	0FFECCh	54
USCI_A2 Receive or Transmit	UCA2RXIFG, UCA2TXIFG (UCA2IV) ^{(1) (3)}	Maskable	0FFEAh	53
USCI_B2 Receive or Transmit	UCB2RXIFG, UCB2TXIFG (UCB2IV) ^{(1) (3)}	Maskable	0FFE8h	52
TA0	TA0CCR0 CCIFG0 ⁽³⁾	Maskable	0FFE6h	51
TA0	TA0CCR1 CCIFG1 to TA0CCR4 CCIFG4, TA0IFG (TA0IV) ^{(1) (3)}	Maskable	0FFE4h	50
Reserved	Reserved ⁽⁵⁾	Maskable	0FFE2h	49
DMA	DMA0IFG, DMA1IFG, DMA2IFG (DMAIV) ^{(1) (3)}	Maskable	0FFE0h	48
USCI_A3 Receive or Transmit	UCA3RXIFG, UCA3TXIFG (UCA3IV) ^{(1) (3)}	Maskable	0FFDEh	47
USCI_B3 Receive or Transmit	UCB3RXIFG, UCB3TXIFG (UCB3IV) ^{(1) (3)}	Maskable	0FFDCh	46
TB0	TB0CCR0 CCIFG0 ⁽³⁾	Maskable	0FFDAh	45
TB0	TB0CCR1 CCIFG1 to TB0CCR6 CCIFG6, TB0IFG (TB0IV) ^{(1) (3)}	Maskable	0FFD8h	44
TA1	TA1CCR0 CCIFG0 ⁽³⁾	Maskable	0FFD6h	43
TA1	TA1CCR1 CCIFG1 to TA1CCR2 CCIFG2, TA1IFG (TA1IV) ^{(1) (3)}	Maskable	0FFD4h	42
I/O Port P1	P1IFG.0 to P1IFG.7 (P1IV) ^{(1) (3)}	Maskable	0FFD2h	41
TA2	TA2CCR0 CCIFG0 ⁽³⁾	Maskable	0FFD0h	40
TA2	TA2CCR1 CCIFG1 to TA2CCR2 CCIFG2, TA2IFG (TA2IV) ^{(1) (3)}	Maskable	0FFCEh	39
I/O Port P2	P2IFG.0 to P2IFG.7 (P2IV) ^{(1) (3)}	Maskable	0FFCCh	38

(1) Multiple source flags

(2) A reset is generated if the CPU tries to fetch instructions from within peripheral space or vacant memory space.

(Non)maskable: the individual interrupt-enable bit can disable an interrupt event, but the general-interrupt enable cannot disable it.

(3) Interrupt flags are located in the module.

(4) Only on devices with ADC, otherwise reserved

(5) Reserved interrupt vectors at addresses are not used in this device and can be used for regular program code if necessary. To maintain compatibility with other devices, it is recommended to reserve these locations.

Table 4. Interrupt Sources, Flags, and Vectors (continued)

INTERRUPT SOURCE	INTERRUPT FLAG	SYSTEM INTERRUPT	WORD ADDRESS	PRIORITY
RTC_A	RTCRDYIFG, RTCTEVIFG, RTCAIFG, RT0PSIFG, RT1PSIFG (RTCIV) ^{(1) (3)}	Maskable	0FFCAh	37
I/O Port P6	P6IFG.0 to P6IFG.7 (P6IV) ^{(1) (3)}	Maskable	0FFC8h	36
Reserved	Reserved ⁽⁵⁾		0FFC6h	35
			⋮	⋮
			0FF80h	0, lowest

Memory Organization

Table 5. Memory Organization⁽¹⁾

		MSP430F5259, MSP430F5258, MSP430F5255, MSP430F5254	MSP430F5257, MSP430F5256, MSP430F5253, MSP430F5252
Memory (flash) Main: interrupt vector	Total Size	128 KB 00FFFFh-00FF80h	128 KB 00FFFFh-00FF80h
Main: code memory	Bank D	32 KB 002A3FFh-0022400h	32 KB 002A3FFh-0022400h
	Bank C	32 KB 00223FFh-001A400h	32 KB 00223FFh-001A400h
	Bank B	32 KB 001A3FFh-0012400h	32 KB 001A3FFh-0012400h
	Bank A	32 KB 00123FFh-00A400h	32 KB 00123FFh-00A400h
RAM	Sector 7	4 KB 00A3FFh-009400h	n/a
	Sector 6	4 KB 0093FFh-008400h	n/a
	Sector 5	4 KB 0083FFh-007400h	n/a
	Sector 4	4 KB 0073FFh-006400h	n/a
	Sector 3	4 KB 0063FFh-005400h	4 KB 0063FFh-005400h
	Sector 2	4 KB 0053FFh-004400h	4 KB 0053FFh-004400h
	Sector 1	4 KB 0043FFh-003400h	4 KB 0043FFh-003400h
	Sector 0	4 KB 0033FFh-002400h	4 KB 0033FFh-002400h
TI factory memory (ROM)	A	128 B 001BFFh-001B80h	128 B 001BFFh-001B80h
	B	128 B 001B7Fh-001B00h	128 B 001B7Fh-001B00h
	C	128 B 001AFFh-001A80h	128 B 001AFFh-001A80h
	D	128 B 001A7Fh-001A00h	128 B 001A7Fh-001A00h

(1) N/A = Not available

Table 5. Memory Organization⁽¹⁾ (continued)

		MSP430F5259, MSP430F5258, MSP430F5255, MSP430F5254	MSP430F5257, MSP430F5256, MSP430F5253, MSP430F5252
Information memory (flash)	Info A	128 B 0019FFh-001980h	128 B 0019FFh-001980h
	Info B	128 B 00197Fh-001900h	128 B 00197Fh-001900h
	Info C	128 B 0018FFh-001880h	128 B 0018FFh-001880h
	Info D	128 B 00187Fh-001800h	128 B 00187Fh-001800h
Bootstrap loader (BSL) memory (flash)	BSL 3	512 B 0017FFh-001600h	512 B 0017FFh-001600h
	BSL 2	512 B 0015FFh-001400h	512 B 0015FFh-001400h
	BSL 1	512 B 0013FFh-001200h	512 B 0013FFh-001200h
	BSL 0	512 B 0011FFh-001000h	512 B 0011FFh-001000h
Peripherals	Size	4 KB 000FFFh-0h	4 KB 000FFFh-0h

Bootstrap Loader (BSL)

NOTE

Devices from TI come factory programmed with either an I2C-based BSL or a timer-based UART BSL. Refer to [Table 1](#) to determine which BSL type is implemented.

Bootstrap Loader - I2C

The I2C BSL enables users to program the flash memory or RAM using a I2C serial interface. Access to the device memory via the BSL is protected by an user-defined password.

When using the BSL, it requires a specific entry sequence on the $\overline{\text{RST}}/\text{NMI}$ and BSLEN pins. [Table 6](#) shows the required pins and their functions. For further details on interfacing to development tools and device programmers, see the *MSP430™ Hardware Tools User's Guide (SLAU278)*. For a complete description of the features of the BSL and its implementation, see the *MSP430™ Programming Via the Bootstrap Loader User's Guide (SLAU319)*.

Table 6. BSL Pin Requirements and Functions

DEVICE SIGNAL	BSL FUNCTION
$\overline{\text{RST}}/\text{NMI}$	External reset
BSLEN	Enable BSL
P4.1/PM_UCB1SDA	I2C data
P4.2/PM_UCB1SCL	I2C clock
DVCC, AVCC	Device power supply
DVIO	I/O power supply
DVSS	Ground supply

NOTE

To invoke the BSL from the DVIO domain, the $\overline{\text{RST}}/\text{NMI}$ and BSLEN pins must be used for the entry sequence. It is critical not to confuse the $\overline{\text{RST}}/\text{NMI}$ pin with the $\overline{\text{RSTDVCC}}/\text{SBWTDIO}$ pin. In other MSP430 devices, SBWTDIO is shared with the $\overline{\text{RST}}/\text{NMI}$ pin and $\overline{\text{RSTDVCC}}$ does not exist. Additional information can be found in *Designing with MSP430F522x and MSP430F521x Devices (SLAA558)*.

Bootstrap Loader - UART

The UART BSL enables users to program the flash memory or RAM using a UART serial interface. Access to the device memory via the BSL is protected by an user-defined password. Because the F525x have split I/O power domains, it is possible to interface with the BSL from either the DVCC or DVIO supply domains. This is useful when the MSP430 is interfacing to a host on the DVIO supply domain. The BSL interface on the DVIO supply domain (Table 8) uses the USCI_A0 module configured as a UART. The BSL interface on the DVCC supply domain (Table 7) uses a timer-based UART.

For applications in which it is desirable to have BSL communication based on the DVCC supply domain, entry to the BSL requires a specific sequence on the RSTDVCC/SBWTIO and TEST/SBWTCK pins. Table 7 shows the required pins and their function.

Table 7. DVCC BSL Pin Requirements and Functions

DEVICE SIGNAL	BSL FUNCTION
$\overline{\text{RSTDVCC/SBWTIO}}$	External reset
TEST/SBWTCK	Enable BSL
P6.1	Data transmit
P6.2	Data receive
DVCC, AVCC	Device power supply
DVIO	I/O power supply
DVSS	Ground supply

NOTE

Devices that are factory programmed with an UART BSL use the DVCC power supply domain pin configuration per default (see Table 7).

NOTE

To invoke the BSL from the DVCC domain, the $\overline{\text{RSTDVCC/SBWTIO}}$ and TEST/SBWTCK pins must be used for the entry sequence. It is critical not to confuse the RST/NMI pin with the $\overline{\text{RSTDVCC/SBWTIO}}$ pin. In other MSP430 devices, SBWTIO is shared with the RST/NMI pin and RSTDVCC does not exist. Additional information can be found in *Designing with MSP430F522x and MSP430F521x Devices* (SLAA558).

When using the DVIO supply domain for the BSL, entry to the BSL requires a specific sequence on the $\overline{\text{RST/NMI}}$ and BLEN pins. Table 8 shows the required pins and their functions. For further details on interfacing to development tools and device programmers, see the *MSP430™ Hardware Tools User's Guide* (SLAU278). For a complete description of the features of the BSL and its implementation, see the *MSP430™ Programming Via the Bootstrap Loader User's Guide* (SLAU319). The BSL on the DVIO supply domain uses the USCI_A0 module configured as a UART.

Table 8. DVIO BSL Pin Requirements and Functions

DEVICE SIGNAL	BSL FUNCTION
$\overline{\text{RST/NMI}}$	External reset
BLEN	Enable BSL
P3.3	Data transmit
P3.4	Data receive
DVCC, AVCC	Device power supply
DVIO	I/O power supply
DVSS	Ground supply

NOTE

To invoke the BSL from the DVIO domain, the $\overline{\text{RST}}/\text{NMI}$ along with the BSLEN pins must be used for the entry sequence (see [DVIO BSL Entry](#)). It is critical not to confuse the $\overline{\text{RST}}/\text{NMI}$ pin with the $\overline{\text{RSTDVCC}}/\text{SBWTDIO}$ pin. In other MSP430 devices, SBWTDIO is shared with the $\overline{\text{RST}}/\text{NMI}$ pin and $\overline{\text{RSTDVCC}}$ does not exist. Additional information can be found in *Designing with MSP430F522x and MSP430F521x Devices* ([SLAA558](#)).

JTAG Operation

JTAG Standard Interface

The MSP430 family supports the standard JTAG interface which requires four signals for sending and receiving data. The JTAG signals are shared with general-purpose I/O. The TEST/SBWTCCK pin is used to enable the JTAG signals. In addition to these signals, the $\overline{\text{RSTDVCC}}/\text{SBWTDIO}$ is required to interface with MSP430 development tools and device programmers. The JTAG pin requirements are shown in [Table 9](#). For further details on interfacing to development tools and device programmers, see the *MSP430™ Hardware Tools User's Guide* ([SLAU278](#)). For a complete description of the features of the JTAG interface and its implementation, see *MSP430™ Programming Via the JTAG Interface* ([SLAU320](#)). Additional information can be found in *Designing with MSP430F522x and MSP430F521x Devices* ([SLAA558](#)).

Table 9. JTAG Pin Requirements and Functions

DEVICE SIGNAL	DIRECTION	FUNCTION
PJ.3/TCK	IN	JTAG clock input
PJ.2/TMS	IN	JTAG state control
PJ.1/TDI/TCLK	IN	JTAG data input, TCLK input
PJ.0/TDO	OUT	JTAG data output
TEST/SBWTCCK	IN	Enable JTAG pins
$\overline{\text{RSTDVCC}}/\text{SBWTDIO}$	IN	External reset
DVCC, AVCC		Device power supply
DVIO		I/O power supply
DVSS		Ground supply

NOTE

Traditionally, on other MSP430 devices, the $\overline{\text{RST}}/\text{NMI}$ pin is used for SBWTDIO, so care must be taken not to mistakenly use the incorrect pin. On the F525x series of devices, it is required to use $\overline{\text{RSTDVCC}}$ for SBWTDIO as shown in [Table 9](#). Additional information can be found in *Designing with MSP430F522x and MSP430F521x Devices* ([SLAA558](#)).

Spy-Bi-Wire Interface

In addition to the standard JTAG interface, the MSP430 family supports the two wire Spy-Bi-Wire interface. Spy-Bi-Wire can be used to interface with MSP430 development tools and device programmers. The Spy-Bi-Wire interface pin requirements are shown in [Table 10](#). For further details on interfacing to development tools and device programmers, see the *MSP430™ Hardware Tools User's Guide (SLAU278)*. For a complete description of the features of the JTAG interface and its implementation, see *MSP430™ Programming Via the JTAG Interface (SLAU320)*. Additional information can be found in *Designing with MSP430F522x and MSP430F521x Devices (SLAA558)*.

Table 10. Spy-Bi-Wire Pin Requirements and Functions

DEVICE SIGNAL	DIRECTION	FUNCTION
TEST/SBWTCK	IN	Spy-Bi-Wire clock input
$\overline{\text{RSTDVCC}}/\text{SBWTDIO}$	IN, OUT	Spy-Bi-Wire data input/output
DVCC, AVCC		Device power supply
DVIO		I/O power supply
DVSS		Ground supply

NOTE

Traditionally, on other MSP430 devices, the $\overline{\text{RST}}/\text{NMI}$ pin is used for SBWTDIO, so care must be taken not to mistakenly use the incorrect pin. On the F525x series of devices, it is required to use $\overline{\text{RSTDVCC}}$ for SBWTDIO as shown in [Table 10](#). Additional information can be found in *Designing with MSP430F522x and MSP430F521x Devices (SLAA558)*.

Flash Memory ([Link to user's guide](#))

The flash memory can be programmed via the JTAG port, Spy-Bi-Wire (SBW), the BSL, or in-system by the CPU. The CPU can perform single-byte, single-word, and long-word writes to the flash memory. Features of the flash memory include:

- Flash memory has n segments of main memory and four segments of information memory (A to D) of 128 bytes each. Each segment in main memory is 512 bytes in size.
- Segments 0 to n may be erased in one step, or each segment may be individually erased.
- Segments A to D can be erased individually. Segments A to D are also called *information memory*.
- Segment A can be locked separately.

RAM Memory ([Link to user's guide](#))

The RAM memory is made up of n sectors. Each sector can be completely powered down to reduce leakage; however, all data is lost during power down. Features of the RAM memory include:

- RAM memory has n sectors. The sizes of the sectors can be found in [Memory Organization](#).
- Each sector 0 to n can be complete disabled; however, all data in a sector is lost when it is disabled.
- Each sector 0 to n automatically enters low-power retention mode when possible.

Peripherals

Peripherals are connected to the CPU through data, address, and control buses and can be handled using all instructions. For complete module descriptions, see the *MSP430x5xx and MSP430x6xx Family User's Guide (SLAU208)*.

Digital I/O ([Link to user's guide](#))

- All individual I/O bits are independently programmable.
- Any combination of input, output, and interrupt conditions is possible.
- Pullup or pulldown on all ports is programmable.
- Drive strength on all ports is programmable.
- Edge-selectable interrupt and LPM4.5 wakeup input capability is available for all bits of ports P1, P2.
- Edge-selectable interrupt capability is available for all bits of port P6.
- Read and write access to port-control registers is supported by all instructions.
- Ports can be accessed byte-wise or word-wise in pairs.

Port Mapping Controller ([Link to user's guide](#))

The port mapping controller allows the flexible and reconfigurable mapping of digital functions to port P4.

Table 11. Port Mapping Mnemonics and Functions

VALUE	PxMAPy MNEMONIC	INPUT PIN FUNCTION	OUTPUT PIN FUNCTION
0	PM_NONE	None	DVSS
1	PM_CBOUT0	-	COMP_B output
	PM_TB0CLK	TB0 clock input	
2	PM_ADC10CLK	-	ADC10CLK
	PM_DMAE0	DMAE0 input	
3	PM_SVMOUT	-	SVM output
	PM_TB0OUTH	TB0 high-impedance input TB0OUTH	
4	PM_TB0CCR0A	TB0 CCR0 capture input CCI0A	TB0 CCR0 compare output Out0
5	PM_TB0CCR1A	TB0 CCR1 capture input CCI1A	TB0 CCR1 compare output Out1
6	PM_TB0CCR2A	TB0 CCR2 capture input CCI2A	TB0 CCR2 compare output Out2
7	PM_TB0CCR3A	TB0 CCR3 capture input CCI3A	TB0 CCR3 compare output Out3
8	PM_TB0CCR4A	TB0 CCR4 capture input CCI4A	TB0 CCR4 compare output Out4
9	PM_TB0CCR5A	TB0 CCR5 capture input CCI5A	TB0 CCR5 compare output Out5
10	PM_TB0CCR6A	TB0 CCR6 capture input CCI6A	TB0 CCR6 compare output Out6
11	PM_UCA1RXD	USCI_A1 UART RXD (direction controlled by USCI - input)	
	PM_UCA1SOMI	USCI_A1 SPI slave out master in (direction controlled by USCI)	
12	PM_UCA1TXD	USCI_A1 UART TXD (direction controlled by USCI - output)	
	PM_UCA1SIMO	USCI_A1 SPI slave in master out (direction controlled by USCI)	
13	PM_UCA1CLK	USCI_A1 clock input/output (direction controlled by USCI)	
	PM_UCB1STE	USCI_B1 SPI slave transmit enable (direction controlled by USCI)	
14	PM_UCB1SOMI	USCI_B1 SPI slave out master in (direction controlled by USCI)	
	PM_UCB1SCL	USCI_B1 I2C clock (open drain and direction controlled by USCI)	
15	PM_UCB1SIMO	USCI_B1 SPI slave in master out (direction controlled by USCI)	
	PM_UCB1SDA	USCI_B1 I2C data (open drain and direction controlled by USCI)	
16	PM_UCB1CLK	USCI_B1 clock input/output (direction controlled by USCI)	
	PM_UCA1STE	USCI_A1 SPI slave transmit enable (direction controlled by USCI)	
17	PM_CBOUT1	None	COMP_B output
18	PM_MCLK	None	MCLK
19	PM_RTCCLK	None	RTCCLK output

Table 11. Port Mapping Mnemonics and Functions (continued)

VALUE	PxMAPy MNEMONIC	INPUT PIN FUNCTION	OUTPUT PIN FUNCTION
20	PM_UCA0RXD	USCI_A0 UART RXD (direction controlled by USCI - input)	
	PM_UCA0SOMI	USCI_A0 SPI slave out master in (direction controlled by USCI)	
21	PM_UCA0TXD	USCI_A0 UART TXD (direction controlled by USCI - output)	
	PM_UCA0SIMO	USCI_A0 SPI slave in master out (direction controlled by USCI)	
22	PM_UCA0CLK	USCI_A0 clock input/output (direction controlled by USCI)	
	PM_UCB0STE	USCI_B0 SPI slave transmit enable (direction controlled by USCI)	
23	PM_UCB0SOMI	USCI_B0 SPI slave out master in (direction controlled by USCI)	
	PM_UCB0SCL	USCI_B0 I2C clock (open drain and direction controlled by USCI)	
24	PM_UCB0SIMO	USCI_B0 SPI slave in master out (direction controlled by USCI)	
	PM_UCB0SDA	USCI_B0 I2C data (open drain and direction controlled by USCI)	
25	PM_UCB0CLK	USCI_B0 clock input/output (direction controlled by USCI)	
	PM_UCA0STE	USCI_A0 SPI slave transmit enable (direction controlled by USCI)	
26	PM_UCA3RXD	USCI_A3 UART RXD (direction controlled by USCI - input)	
	PM_UCA3SOMI	USCI_A3 SPI slave out master in (direction controlled by USCI)	
27	PM_UCA3TXD	USCI_A3 UART TXD (direction controlled by USCI - output)	
	PM_UCA3SIMO	USCI_A3 SPI slave in master out (direction controlled by USCI)	
28	PM_UCB3SIMO	USCI_B3 SPI slave in master out (direction controlled by USCI)	
	PM_UCB3SDA	USCI_B3I2C data (open drain and direction controlled by USCI)	
29	PM_UCB3SOMI	USCI_B3 SPI slave out master in (direction controlled by USCI)	
	PM_UCB3SCL	USCI_B3 I2C clock (open drain and direction controlled by USCI)	
30	Reserved	Reserved	
31 (0FFh) ⁽¹⁾	PM_ANALOG	Disables the output driver and the input Schmitt trigger to prevent parasitic cross currents when applying analog signals	

(1) The value of the PM_ANALOG mnemonic is set to 0FFh. The port mapping registers are only 5 bits wide and the upper bits are ignored resulting in a read out value of 31.

Table 12. Default Mapping

PIN	PxMAPy MNEMONIC	INPUT PIN FUNCTION	OUTPUT PIN FUNCTION
P4.0/P4MAP0	PM_UCB1STE/PM_UCA1CLK	USCI_B1 SPI slave transmit enable (direction controlled by USCI) USCI_A1 clock input/output (direction controlled by USCI)	
P4.1/P4MAP1	PM_UCB1SIMO/PM_UCB1SDA	USCI_B1 SPI slave in master out (direction controlled by USCI) USCI_B1 I2C data (open drain and direction controlled by USCI)	
P4.2/P4MAP2	PM_UCB1SOMI/PM_UCB1SCL	USCI_B1 SPI slave out master in (direction controlled by USCI) USCI_B1 I2C clock (open drain and direction controlled by USCI)	
P4.3/P4MAP3	PM_UCB1CLK/PM_UCA1STE	USCI_A1 SPI slave transmit enable (direction controlled by USCI) USCI_B1 clock input/output (direction controlled by USCI)	
P4.4/P4MAP4	PM_UCA1TXD/PM_UCA1SIMO	USCI_A1 UART TXD (Direction controlled by USCI - output) USCI_A1 SPI slave in master out (direction controlled by USCI)	
P4.5/P4MAP5	PM_UCA1RXD/PM_UCA1SOMI	USCI_A1 UART RXD (Direction controlled by USCI - input) USCI_A1 SPI slave out master in (direction controlled by USCI)	
P4.6/P4MAP6	PM_UCA3TXD/PM_UCA3SIMO	USCI_A3 UART TXD (Direction controlled by USCI - output) USCI_A3 SPI slave in master out (direction controlled by USCI)	
P4.7/P4MAP7	PM_UCA3RXD/PM_UCA3SOMI	USCI_A3 UART RXD (Direction controlled by USCI - input) USCI_A3 SPI slave out master in (direction controlled by USCI)	

Oscillator and System Clock ([Link to user's guide](#))

The clock system is supported by the Unified Clock System (UCS) module, which includes support for a 32-kHz watch crystal oscillator (XT1 LF mode; XT1 HF mode is not supported), an internal very-low-power low-frequency oscillator (VLO), an internal trimmed low-frequency oscillator (REFO), an integrated internal digitally controlled oscillator (DCO), and a high-frequency crystal oscillator (XT2). The UCS module is designed to meet the requirements of both low system cost and low power consumption. The UCS module features digital frequency locked loop (FLL) hardware that, in conjunction with a digital modulator, stabilizes the DCO frequency to a programmable multiple of the selected FLL reference frequency. The internal DCO provides a fast turn-on clock source and stabilizes in 3.5 μ s (typical). The UCS module provides the following clock signals:

- Auxiliary clock (ACLK), sourced from a 32-kHz watch crystal (XT1), a high-frequency crystal (XT2), the internal low-frequency oscillator (VLO), the trimmed low-frequency oscillator (REFO), or the internal digitally controlled oscillator DCO.
- Main clock (MCLK), the system clock used by the CPU. MCLK can be sourced by same sources made available to ACLK.
- Sub-Main clock (SMCLK), the subsystem clock used by the peripheral modules. SMCLK can be sourced by same sources made available to ACLK.
- ACLK/n, the buffered output of ACLK, ACLK/2, ACLK/4, ACLK/8, ACLK/16, ACLK/32.

Power Management Module (PMM) ([Link to user's guide](#))

The PMM includes an integrated voltage regulator that supplies the core voltage to the device and contains programmable output levels to provide for power optimization. The PMM also includes supply voltage supervisor (SVS) and supply voltage monitoring (SVM) circuitry, and brownout protection. The brownout circuit is implemented to provide the proper internal reset signal to the device during power-on and power-off. The SVS and SVM circuitry detects if the supply voltage drops below a user-selectable level and supports both supply voltage supervision (the device is automatically reset) and supply voltage monitoring (the device is not automatically reset). SVS and SVM circuitry is available on the primary supply and core supply.

Hardware Multiplier ([Link to user's guide](#))

The multiplication operation is supported by a dedicated peripheral module. The module performs operations with 32-bit, 24-bit, 16-bit, and 8-bit operands. The module supports signed and unsigned multiplication as well as signed and unsigned multiply-and-accumulate operations.

Real-Time Clock (RTC_A) ([Link to user's guide](#))

The RTC_A module can be used as a general-purpose 32-bit counter (counter mode) or as an integrated real-time clock (RTC) (calendar mode). In counter mode, the RTC_A also includes two independent 8-bit timers that can be cascaded to form a 16-bit timer or counter. Both timers can be read and written by software. Calendar mode integrates an internal calendar that compensates for months with less than 31 days and includes leap year correction. The RTC_A also supports flexible alarm functions and offset-calibration hardware.

Watchdog Timer (WDT_A) ([Link to user's guide](#))

The primary function of the WDT_A module is to perform a controlled system restart after a software problem occurs. If the selected time interval expires, a system reset is generated. If the watchdog function is not needed in an application, the module can be configured as an interval timer and can generate interrupts at selected time intervals.

System Module (SYS) (Link to user's guide)

The SYS module handles many of the system functions within the device. These include power-on reset (POR) and power-up clear (PUC) handling, NMI source selection and management, reset interrupt vector generators, bootstrap loader (BSL) entry mechanisms, and configuration management (device descriptors). It also includes a data exchange mechanism when using JTAG that is called a JTAG mailbox and that can be used in the application.

Table 13. System Module Interrupt Vector Registers

INTERRUPT VECTOR REGISTER	ADDRESS	INTERRUPT EVENT	VALUE	PRIORITY
SYSRSTIV, System Reset	019Eh	No interrupt pending	00h	
		Brownout (BOR)	02h	Highest
		$\overline{\text{RST}}$ /NMI (BOR)	04h	
		PMMSWBOR (BOR)	06h	
		Wakeup from LPMx.5	08h	
		Security violation (BOR)	0Ah	
		SVSL (POR)	0Ch	
		SVSH (POR)	0Eh	
		SVML_OVP (POR)	10h	
		SVMH_OVP (POR)	12h	
		PMMSWPOR (POR)	14h	
		WDT timeout (PUC)	16h	
		WDT password violation (PUC)	18h	
		KEYV flash password violation (PUC)	1Ah	
		Reserved	1Ch	
		Peripheral area fetch (PUC)	1Eh	
		PMM password violation (PUC)	20h	
Reserved	22h to 3Eh	Lowest		
SYSSNIV, System NMI	019Ch	No interrupt pending	00h	
		SVMLIFG	02h	Highest
		SVMHIFG	04h	
		SVSMLDLYIFG	06h	
		SVSMHDLYIFG	08h	
		VMAIFG	0Ah	
		JMBINIFG	0Ch	
		JMBOUTIFG	0Eh	
		SVMLVLRIFG	10h	
		SVMHVLRIFG	12h	
		Reserved	14h to 1Eh	Lowest
		SYSUNIV, User NMI	019Ah	No interrupt pending
NMIFG	02h			Highest
OFIFG	04h			
ACCVIFG	06h			
Reserved	08h			
Reserved	0Ah to 1Eh			Lowest

PRODUCT PREVIEW

DMA Controller ([Link to user's guide](#))

The DMA controller allows movement of data from one memory address to another without CPU intervention. For example, the DMA controller can be used to move data from the ADC10_A conversion memory to RAM. Using the DMA controller can increase the throughput of peripheral modules. The DMA controller reduces system power consumption by allowing the CPU to remain in sleep mode, without having to awaken to move data to or from a peripheral.

Table 14. DMA Trigger Assignments⁽¹⁾

TRIGGER	CHANNEL		
	0	1	2
0	DMAREQ	DMAREQ	DMAREQ
1	TA0CCR0 CCIFG	TA0CCR0 CCIFG	TA0CCR0 CCIFG
2	TA0CCR2 CCIFG	TA0CCR2 CCIFG	TA0CCR2 CCIFG
3	TA1CCR0 CCIFG	TA1CCR0 CCIFG	TA1CCR0 CCIFG
4	TA1CCR2 CCIFG	TA1CCR2 CCIFG	TA1CCR2 CCIFG
5	TA2CCR0 CCIFG	TA2CCR0 CCIFG	TA2CCR0 CCIFG
6	TA2CCR2 CCIFG	TA2CCR2 CCIFG	TA2CCR2 CCIFG
7	TB0CCR0 CCIFG	TB0CCR0 CCIFG	TB0CCR0 CCIFG
8	TB0CCR2 CCIFG	TB0CCR2 CCIFG	TB0CCR2 CCIFG
9	UCA2RXIFG	UCA2RXIFG	UCA2RXIFG
10	UCA2TXIFG	UCA2TXIFG	UCA2TXIFG
11	UCB2RXIFG	UCB2RXIFG	UCB2RXIFG
12	UCB2TXIFG	UCB2TXIFG	UCB2TXIFG
13	Reserved	Reserved	Reserved
14	Reserved	Reserved	Reserved
15	Reserved	Reserved	Reserved
16	UCA0RXIFG	UCA0RXIFG	UCA0RXIFG
17	UCA0TXIFG	UCA0TXIFG	UCA0TXIFG
18	UCB0RXIFG	UCB0RXIFG	UCB0RXIFG
19	UCB0TXIFG	UCB0TXIFG	UCB0TXIFG
20	UCA1RXIFG	UCA1RXIFG	UCA1RXIFG
21	UCA1TXIFG	UCA1TXIFG	UCA1TXIFG
22	UCB1RXIFG	UCB1RXIFG	UCB1RXIFG
23	UCB1TXIFG	UCB1TXIFG	UCB1TXIFG
24	ADC10IFG0 ⁽²⁾	ADC10IFG0 ⁽²⁾	ADC10IFG0 ⁽²⁾
25	UCA3RXIFG	UCA3RXIFG	UCA3RXIFG
26	UCA3TXIFG	UCA3TXIFG	UCA3TXIFG
27	UCB3RXIFG	UCB3RXIFG	UCB3RXIFG
28	UCB3TXIFG	UCB3TXIFG	UCB3TXIFG
29	MPY ready	MPY ready	MPY ready
30	DMA2IFG	DMA0IFG	DMA1IFG
31	DMAE0	DMAE0	DMAE0

- (1) If a reserved trigger source is selected, no trigger is generated.
 (2) Only on devices with ADC; reserved on devices without ADC

Universal Serial Communication Interface (USCI) (Links to user's guide: [UART Mode](#),[SPI Mode](#),[I2C Mode](#))

The USCI modules are used for serial data communication. The USCI module supports synchronous communication protocols such as SPI (3 or 4 pin) and I²C, and asynchronous communication protocols such as UART, enhanced UART with automatic baudrate detection, and IrDA. Each USCI module contains two portions, A and B.

The USCI_An module provides support for SPI (3 pin or 4 pin), UART, enhanced UART, or IrDA.

The USCI_Bn module provides support for SPI (3 pin or 4 pin) or I2C.

The MSP430F525x include four complete USCI modules (n = 0, 1, 2, 3).

TA0 (Link to user's guide)

TA0 is a 16-bit timer/counter (Timer_A type) with five capture/compare registers. It can support multiple captures or compares, PWM outputs, and interval timing. It also has extensive interrupt capabilities. Interrupts may be generated from the counter on overflow conditions and from each of the capture/compare registers.

Table 15. TA0 Signal Connections

INPUT PIN NUMBER	DEVICE INPUT SIGNAL	MODULE INPUT SIGNAL	MODULE BLOCK	MODULE OUTPUT SIGNAL	DEVICE OUTPUT SIGNAL	OUTPUT PIN NUMBER
RGC, ZQE, YFF						RGC, ZQE, YFF
18, H2, G2 - P1.0	TA0CLK	TACLK	Timer	NA	NA	
	ACLK (internal)	ACLK				
	SMCLK (internal)	SMCLK				
18, H2, G2 - P1.0	TA0CLK	$\overline{\text{TACLK}}$	CCR0	TA0	TA0.0	
19, H3, G3 - P1.1	TA0.0	CCI0A				19, H3, G3 - P1.1
	DVSS	CCI0B				
	DVSS	GND				
	DVCC	V _{CC}				
20, J3, H3 - P1.2	TA0.1	CCI1A	CCR1	TA1	TA0.1	20, J3, H3 - P1.2
	CBOU (internal)	CCI1B				ADC10 (internal) ADC10SHSx = {1}
	DVSS	GND				
	DVCC	V _{CC}				
21, G4, F3 - P1.3	TA0.2	CCI2A	CCR2	TA2	TA0.2	21, G4, F3 - P1.3
	ACLK (internal)	CCI2B				
	DVSS	GND				
	DVCC	V _{CC}				
22, H4, E3 - P1.4	TA0.3	CCI3A	CCR3	TA3	TA0.3	22, H4, E3 - P1.4
	DVSS	CCI3B				
	DVSS	GND				
	DVCC	V _{CC}				
23, J4, H4 - P1.5	TA0.4	CCI4A	CCR4	TA4	TA0.4	23, J4, H4 - P1.5
	DVSS	CCI4B				
	DVSS	GND				
	DVCC	V _{CC}				

TA1 (Link to user's guide)

TA1 is a 16-bit timer/counter (Timer_A type) with three capture/compare registers. It can support multiple captures or compares, PWM outputs, and interval timing. It also has extensive interrupt capabilities. Interrupts may be generated from the counter on overflow conditions and from each of the capture/compare registers.

Table 16. TA1 Signal Connections

INPUT PIN NUMBER	DEVICE INPUT SIGNAL	MODULE INPUT SIGNAL	MODULE BLOCK	MODULE OUTPUT SIGNAL	DEVICE OUTPUT SIGNAL	OUTPUT PIN NUMBER
RGC, ZQE, YFF						RGC, ZQE, YFF
24, G5, G4 - P1.6	TA1CLK	TACLK	Timer	NA	NA	
	ACLK (internal)	ACLK				
	SMCLK (internal)	SMCLK				
24, G5, G4 - P1.6	TA1CLK	$\overline{\text{TACLK}}$				
25, H5, F4 - P1.7	TA1.0	CC10A	CCR0	TA0	TA1.0	25, H5, F4 - P1.7
	DVSS	CC10B				
	DVSS	GND				
	DVCC	V _{CC}				
26, J5, H5 - P2.0	TA1.1	CC11A	CCR1	TA1	TA1.1	26, J5, H5 - P2.0
	CBOUT (internal)	CC11B				
	DVSS	GND				
	DVCC	V _{CC}				
27, G6, E4 - P2.1	TA1.2	CC12A	CCR2	TA2	TA1.2	27, G6, E4 - P2.1
	ACLK (internal)	CC12B				
	DVSS	GND				
	DVCC	V _{CC}				

TA2 (Link to user's guide)

TA2 is a 16-bit timer/counter (Timer_A type) with three capture/compare registers. It can support multiple captures or compares, PWM outputs, and interval timing. It also has extensive interrupt capabilities. Interrupts may be generated from the counter on overflow conditions and from each of the capture/compare registers.

Table 17. TA2 Signal Connections

INPUT PIN NUMBER	DEVICE INPUT SIGNAL	MODULE INPUT SIGNAL	MODULE BLOCK	MODULE OUTPUT SIGNAL	DEVICE OUTPUT SIGNAL	OUTPUT PIN NUMBER
RGC, ZQE, YFF						RGC, ZQE, YFF
1, A1, C2 - P6.0	TA2CLK	TACLK	Timer	NA	NA	
	ACLK (internal)	ACLK				
	SMCLK (internal)	SMCLK				
1, A1, C2 - P6.0	TA2CLK	$\overline{\text{TACLK}}$				
2, B2, A1 - P6.1	TA2.0	CC10A	CCR0	TA0	TA2.0	2, B2, A1 - P6.1
	DVSS	CC10B				
	DVSS	GND				
	DVCC	V _{CC}				
3, B1, B2 - P6.2	TA2.1	CC11A	CCR1	TA1	TA2.1	3, B1, B2 - P6.2
	CBOUT (internal)	CC11B				
	DVSS	GND				
	DVCC	V _{CC}				
4, C2, C3 - P6.3	TA2.2	CC12A	CCR2	TA2	TA2.2	4, C2, C3 - P6.3
	ACLK (internal)	CC12B				
	DVSS	GND				
	DVCC	V _{CC}				

TB0 (Link to user's guide)

TB0 is a 16-bit timer/counter (Timer_B type) with seven capture/compare registers. It can support multiple captures or compares, PWM outputs, and interval timing. It also has extensive interrupt capabilities. Interrupts may be generated from the counter on overflow conditions and from each of the capture/compare registers.

Table 18. TB0 Signal Connections

INPUT PIN NUMBER	DEVICE INPUT SIGNAL	MODULE INPUT SIGNAL	MODULE BLOCK	MODULE OUTPUT SIGNAL	DEVICE OUTPUT SIGNAL	OUTPUT PIN NUMBER
RGC, ZQE, YFF						RGC, ZQE, YFF
(1)	TB0CLK	TBCLK	Timer	NA	NA	
	ACLK (internal)	ACLK				
	SMCLK (internal)	SMCLK				
(1)	TB0CLK	$\overline{\text{TBCLK}}$				
(1)	TB0.0	CCI0A	CCR0	TB0	TB0.0	(1)
(1)	TB0.0	CCI0B				ADC10 (internal) ADC10SHSx = {2}
	DVSS	GND				
	DVCC	V _{CC}				
(1)	TB0.1	CCI1A	CCR1	TB1	TB0.1	(1)
	CBOU (internal)	CCI1B				ADC10 (internal) ADC10SHSx = {3}
	DVSS	GND				
	DVCC	V _{CC}				
(1)	TB0.2	CCI2A	CCR2	TB2	TB0.2	(1)
(1)	TB0.2	CCI2B				
	DVSS	GND				
	DVCC	V _{CC}				
(1)	TB0.3	CCI3A	CCR3	TB3	TB0.3	(1)
(1)	TB0.3	CCI3B				
	DVSS	GND				
	DVCC	V _{CC}				
(1)	TB0.4	CCI4A	CCR4	TB4	TB0.4	(1)
(1)	TB0.4	CCI4B				
	DVSS	GND				
	DVCC	V _{CC}				
(1)	TB0.5	CCI5A	CCR5	TB5	TB0.5	(1)
(1)	TB0.5	CCI5B				
	DVSS	GND				
	DVCC	V _{CC}				
(1)	TB0.6	CCI6A	CCR6	TB6	TB0.6	(1)
	ACLK (internal)	CCI6B				
	DVSS	GND				
	DVCC	V _{CC}				

(1) Timer functions can be selected by the port mapping controller.

Comparator_B (Link to user's guide)

The primary function of the Comparator_B module is to support precision slope analog-to-digital conversions, battery voltage supervision, and monitoring of external analog signals.

ADC10_A (Link to user's guide)

The ADC10_A module supports fast 10-bit analog-to-digital conversions. The module implements a 10-bit SAR core, sample select control, reference generator, and a conversion result buffer. A window comparator with lower and upper limits allows CPU-independent result monitoring with three window comparator interrupt flags.

CRC16 (Link to user's guide)

The CRC16 module produces a signature based on a sequence of entered data values and can be used for data checking purposes. The CRC16 module signature is based on the CRC-CCITT standard.

REF Voltage Reference (Link to user's guide)

The reference module (REF) is responsible for generation of all critical reference voltages that can be used by the various analog peripherals in the device.

Embedded Emulation Module (EEM) (S Version) (Link to user's guide)

The EEM supports real-time in-system debugging. The S version of the EEM has the following features:

- Three hardware triggers or breakpoints on memory access
- One hardware trigger or breakpoint on CPU register write access
- Up to four hardware triggers can be combined to form complex triggers or breakpoints
- One cycle counter
- Clock control on module level

Peripheral File Map

Table 19. Peripherals

MODULE NAME	BASE ADDRESS	OFFSET ADDRESS RANGE
Special Functions (see Table 20)	0100h	000h-01Fh
PMM (see Table 21)	0120h	000h-010h
Flash Control (see Table 22)	0140h	000h-00Fh
CRC16 (see Table 23)	0150h	000h-007h
RAM Control (see Table 24)	0158h	000h-001h
Watchdog (see Table 25)	015Ch	000h-001h
UCS (see Table 26)	0160h	000h-01Fh
SYS (see Table 27)	0180h	000h-01Fh
Shared Reference (see Table 28)	01B0h	000h-001h
Port Mapping Control (see Table 29)	01C0h	000h-002h
Port Mapping Port P4 (see Table 29)	01E0h	000h-007h
Port P1, P2 (see Table 30)	0200h	000h-01Fh
Port P3, P4 (see Table 31)	0220h	000h-00Bh
Port P5, P6 (see Table 32)	0240h	000h-01Fh
Port P7 (see Table 33)	0260h	000h-00Bh
Port PJ (see Table 34)	0320h	000h-01Fh
TA0 (see Table 35)	0340h	000h-02Eh
TA1 (see Table 36)	0380h	000h-02Eh
TB0 (see Table 37)	03C0h	000h-02Eh
TA2 (see Table 38)	0400h	000h-02Eh
Real-Time Clock (RTC_A) (see Table 39)	04A0h	000h-01Bh
32-Bit Hardware Multiplier (see Table 40)	04C0h	000h-02Fh
DMA General Control (see Table 41)	0500h	000h-00Fh
DMA Channel 0 (see Table 41)	0510h	000h-00Ah
DMA Channel 1 (see Table 41)	0520h	000h-00Ah
DMA Channel 2 (see Table 41)	0530h	000h-00Ah
USCI_A0 (see Table 42)	05C0h	000h-01Fh
USCI_B0 (see Table 43)	05E0h	000h-01Fh
USCI_A1 (see Table 44)	0600h	000h-01Fh
USCI_B1 (see Table 45)	0620h	000h-01Fh
USCI_A2 (see Table 42)	0640h	000h-01Fh
USCI_B2 (see Table 43)	0660h	000h-01Fh
USCI_A3 (see Table 44)	0680h	000h-01Fh
USCI_B3 (see Table 45)	06A0h	000h-01Fh
ADC10_A (see Table 50)	0740h	000h-01Fh
Comparator_B (see Table 51)	08C0h	000h-00Fh

Table 20. Special Function Registers (Base Address: 0100h)

REGISTER DESCRIPTION	REGISTER	OFFSET
SFR interrupt enable	SFRIE1	00h
SFR interrupt flag	SFRIFG1	02h
SFR reset pin control	SFRRPCR	04h

Table 21. PMM Registers (Base Address: 0120h)

REGISTER DESCRIPTION	REGISTER	OFFSET
PMM Control 0	PMMCTL0	00h
PMM control 1	PMMCTL1	02h
SVS high side control	SVSMHCTL	04h
SVS low side control	SVSMLCTL	06h
PMM interrupt flags	PMMIFG	0Ch
PMM interrupt enable	PMMIE	0Eh
PMM power mode 5 control	PM5CTL0	10h

Table 22. Flash Control Registers (Base Address: 0140h)

REGISTER DESCRIPTION	REGISTER	OFFSET
Flash control 1	FCTL1	00h
Flash control 3	FCTL3	04h
Flash control 4	FCTL4	06h

Table 23. CRC16 Registers (Base Address: 0150h)

REGISTER DESCRIPTION	REGISTER	OFFSET
CRC data input	CRC16DI	00h
CRC data input reverse byte	CRCDIRB	02h
CRC initialization and result	CRCINIRES	04h
CRC result reverse byte	CRCRESR	06h

Table 24. RAM Control Registers (Base Address: 0158h)

REGISTER DESCRIPTION	REGISTER	OFFSET
RAM control 0	RCCTL0	00h

Table 25. Watchdog Registers (Base Address: 015Ch)

REGISTER DESCRIPTION	REGISTER	OFFSET
Watchdog timer control	WDTCTL	00h

Table 26. UCS Registers (Base Address: 0160h)

REGISTER DESCRIPTION	REGISTER	OFFSET
UCS control 0	UCSCTL0	00h
UCS control 1	UCSCTL1	02h
UCS control 2	UCSCTL2	04h
UCS control 3	UCSCTL3	06h
UCS control 4	UCSCTL4	08h
UCS control 5	UCSCTL5	0Ah
UCS control 6	UCSCTL6	0Ch
UCS control 7	UCSCTL7	0Eh
UCS control 8	UCSCTL8	10h
UCS control 9	UCSCTL9	12h

Table 27. SYS Registers (Base Address: 0180h)

REGISTER DESCRIPTION	REGISTER	OFFSET
System control	SYSCTL	00h
Bootstrap loader configuration area	SYSBSLC	02h
JTAG mailbox control	SYSJMBC	06h
JTAG mailbox input 0	SYSJMBIO	08h
JTAG mailbox input 1	SYSJMBI1	0Ah
JTAG mailbox output 0	SYSJMBO0	0Ch
JTAG mailbox output 1	SYSJMBO1	0Eh
User NMI vector generator	SYSUNIV	1Ah
System NMI vector generator	SYSSNIV	1Ch
Reset vector generator	SYSRSTIV	1Eh

Table 28. Shared Reference Registers (Base Address: 01B0h)

REGISTER DESCRIPTION	REGISTER	OFFSET
Shared reference control	REFCTL	00h

**Table 29. Port Mapping Registers
(Base Address of Port Mapping Control: 01C0h, Port P4: 01E0h)**

REGISTER DESCRIPTION	REGISTER	OFFSET
Port mapping key/ID register	PMAPKEYID	00h
Port mapping control register	PMAPCTL	02h
Port P4.0 mapping register	P4MAP0	00h
Port P4.1 mapping register	P4MAP1	01h
Port P4.2 mapping register	P4MAP2	02h
Port P4.3 mapping register	P4MAP3	03h
Port P4.4 mapping register	P4MAP4	04h
Port P4.5 mapping register	P4MAP5	05h
Port P4.6 mapping register	P4MAP6	06h
Port P4.7 mapping register	P4MAP7	07h

PRODUCT PREVIEW

Table 30. Port P1, P2 Registers (Base Address: 0200h)

REGISTER DESCRIPTION	REGISTER	OFFSET
Port P1 input	P1IN	00h
Port P1 output	P1OUT	02h
Port P1 direction	P1DIR	04h
Port P1 pullup or pulldown enable	P1REN	06h
Port P1 drive strength	P1DS	08h
Port P1 selection	P1SEL	0Ah
Port P1 interrupt vector word	P1IV	0Eh
Port P1 interrupt edge select	P1IES	18h
Port P1 interrupt enable	P1IE	1Ah
Port P1 interrupt flag	P1IFG	1Ch
Port P2 input	P2IN	01h
Port P2 output	P2OUT	03h
Port P2 direction	P2DIR	05h
Port P2 pullup or pulldown enable	P2REN	07h
Port P2 drive strength	P2DS	09h
Port P2 selection	P2SEL	0Bh
Port P2 interrupt vector word	P2IV	1Eh
Port P2 interrupt edge select	P2IES	19h
Port P2 interrupt enable	P2IE	1Bh
Port P2 interrupt flag	P2IFG	1Dh

Table 31. Port P3, P4 Registers (Base Address: 0220h)

REGISTER DESCRIPTION	REGISTER	OFFSET
Port P3 input	P3IN	00h
Port P3 output	P3OUT	02h
Port P3 direction	P3DIR	04h
Port P3 pullup or pulldown enable	P3REN	06h
Port P3 drive strength	P3DS	08h
Port P3 selection	P3SEL	0Ah
Port P4 input	P4IN	01h
Port P4 output	P4OUT	03h
Port P4 direction	P4DIR	05h
Port P4 pullup or pulldown enable	P4REN	07h
Port P4 drive strength	P4DS	09h
Port P4 selection	P4SEL	0Bh

Table 32. Port P5, P6 Registers (Base Address: 0240h)

REGISTER DESCRIPTION	REGISTER	OFFSET
Port P5 input	P5IN	00h
Port P5 output	P5OUT	02h
Port P5 direction	P5DIR	04h
Port P5 pullup or pulldown enable	P5REN	06h
Port P5 drive strength	P5DS	08h
Port P5 selection	P5SEL	0Ah
Port P6 input	P6IN	01h
Port P6 output	P6OUT	03h
Port P6 direction	P6DIR	05h
Port P6 pullup or pulldown enable	P6REN	07h
Port P6 drive strength	P6DS	09h
Port P6 selection	P6SEL	0Bh
Port P6 interrupt vector word	P6IV	1Eh
Port P6 interrupt edge select	P6IES	19h
Port P6 interrupt enable	P6IE	1Bh
Port P6 interrupt flag	P6IFG	1Dh

Table 33. Port P7 Registers (Base Address: 0260h)

REGISTER DESCRIPTION	REGISTER	OFFSET
Port P7 input	P7IN	00h
Port P7 output	P7OUT	02h
Port P7 direction	P7DIR	04h
Port P7 pullup or pulldown enable	P7REN	06h
Port P7 drive strength	P7DS	08h
Port P7 selection	P7SEL	0Ah

Table 34. Port J Registers (Base Address: 0320h)

REGISTER DESCRIPTION	REGISTER	OFFSET
Port PJ input	PJIN	00h
Port PJ output	PJOUT	02h
Port PJ direction	PJDIR	04h
Port PJ pullup or pulldown enable	PJREN	06h
Port PJ drive strength	PJDS	08h

Table 35. TA0 Registers (Base Address: 0340h)

REGISTER DESCRIPTION	REGISTER	OFFSET
TA0 control	TAOCTL	00h
Capture/compare control 0	TAOCCTL0	02h
Capture/compare control 1	TAOCCTL1	04h
Capture/compare control 2	TAOCCTL2	06h
Capture/compare control 3	TAOCCTL3	08h
Capture/compare control 4	TAOCCTL4	0Ah
TA0 counter register	TAOR	10h
Capture/compare register 0	TAOCCR0	12h
Capture/compare register 1	TAOCCR1	14h
Capture/compare register 2	TAOCCR2	16h
Capture/compare register 3	TAOCCR3	18h
Capture/compare register 4	TAOCCR4	1Ah
TA0 expansion register 0	TAOEX0	20h
TA0 interrupt vector	TAOIV	2Eh

Table 36. TA1 Registers (Base Address: 0380h)

REGISTER DESCRIPTION	REGISTER	OFFSET
TA1 control	TA1CTL	00h
Capture/compare control 0	TA1CCTL0	02h
Capture/compare control 1	TA1CCTL1	04h
Capture/compare control 2	TA1CCTL2	06h
TA1 counter register	TA1R	10h
Capture/compare register 0	TA1CCR0	12h
Capture/compare register 1	TA1CCR1	14h
Capture/compare register 2	TA1CCR2	16h
TA1 expansion register 0	TA1EX0	20h
TA1 interrupt vector	TA1IV	2Eh

Table 37. TB0 Registers (Base Address: 03C0h)

REGISTER DESCRIPTION	REGISTER	OFFSET
TB0 control	TB0CTL	00h
Capture/compare control 0	TB0CCTL0	02h
Capture/compare control 1	TB0CCTL1	04h
Capture/compare control 2	TB0CCTL2	06h
Capture/compare control 3	TB0CCTL3	08h
Capture/compare control 4	TB0CCTL4	0Ah
Capture/compare control 5	TB0CCTL5	0Ch
Capture/compare control 6	TB0CCTL6	0Eh
TB0 register	TB0R	10h
Capture/compare register 0	TB0CCR0	12h
Capture/compare register 1	TB0CCR1	14h
Capture/compare register 2	TB0CCR2	16h
Capture/compare register 3	TB0CCR3	18h
Capture/compare register 4	TB0CCR4	1Ah
Capture/compare register 5	TB0CCR5	1Ch
Capture/compare register 6	TB0CCR6	1Eh
TB0 expansion register 0	TB0EX0	20h
TB0 interrupt vector	TB0IV	2Eh

Table 38. TA2 Registers (Base Address: 0400h)

REGISTER DESCRIPTION	REGISTER	OFFSET
TA2 control	TA2CTL	00h
Capture/compare control 0	TA2CCTL0	02h
Capture/compare control 1	TA2CCTL1	04h
Capture/compare control 2	TA2CCTL2	06h
TA2 counter register	TA2R	10h
Capture/compare register 0	TA2CCR0	12h
Capture/compare register 1	TA2CCR1	14h
Capture/compare register 2	TA2CCR2	16h
TA2 expansion register 0	TA2EX0	20h
TA2 interrupt vector	TA2IV	2Eh

PRODUCT PREVIEW

Table 39. Real-Time Clock Registers (Base Address: 04A0h)

REGISTER DESCRIPTION	REGISTER	OFFSET
RTC control 0	RTCCTL0	00h
RTC control 1	RTCCTL1	01h
RTC control 2	RTCCTL2	02h
RTC control 3	RTCCTL3	03h
RTC prescaler 0 control	RTCPS0CTL	08h
RTC prescaler 1 control	RTCPS1CTL	0Ah
RTC prescaler 0	RTCPS0	0Ch
RTC prescaler 1	RTCPS1	0Dh
RTC interrupt vector word	RTCIV	0Eh
RTC seconds/counter register 1	RTCSEC/RTCNT1	10h
RTC minutes/counter register 2	RTCMIN/RTCNT2	11h
RTC hours/counter register 3	RTCHOUR/RTCNT3	12h
RTC day of week/counter register 4	RTCADOW/RTCNT4	13h
RTC days	RTCDAY	14h
RTC month	RTCMON	15h
RTC year low	RTCYEARL	16h
RTC year high	RTCYEARH	17h
RTC alarm minutes	RTCAMIN	18h
RTC alarm hours	RTCAHOUR	19h
RTC alarm day of week	RTCADOW	1Ah
RTC alarm days	RTCADAY	1Bh

Table 40. 32-Bit Hardware Multiplier Registers (Base Address: 04C0h)

REGISTER DESCRIPTION	REGISTER	OFFSET
16-bit operand 1 – multiply	MPY	00h
16-bit operand 1 – signed multiply	MPYS	02h
16-bit operand 1 – multiply accumulate	MAC	04h
16-bit operand 1 – signed multiply accumulate	MACS	06h
16-bit operand 2	OP2	08h
16 × 16 result low word	RESLO	0Ah
16 × 16 result high word	RESHI	0Ch
16 × 16 sum extension register	SUMEXT	0Eh
32-bit operand 1 – multiply low word	MPY32L	10h
32-bit operand 1 – multiply high word	MPY32H	12h
32-bit operand 1 – signed multiply low word	MPYS32L	14h
32-bit operand 1 – signed multiply high word	MPYS32H	16h
32-bit operand 1 – multiply accumulate low word	MAC32L	18h
32-bit operand 1 – multiply accumulate high word	MAC32H	1Ah
32-bit operand 1 – signed multiply accumulate low word	MACS32L	1Ch
32-bit operand 1 – signed multiply accumulate high word	MACS32H	1Eh
32-bit operand 2 – low word	OP2L	20h
32-bit operand 2 – high word	OP2H	22h
32 × 32 result 0 – least significant word	RES0	24h
32 × 32 result 1	RES1	26h
32 × 32 result 2	RES2	28h
32 × 32 result 3 – most significant word	RES3	2Ah
MPY32 control register 0	MPY32CTL0	2Ch

Table 41. DMA Registers (Base Address DMA General Control: 0500h, DMA Channel 0: 0510h, DMA Channel 1: 0520h, DMA Channel 2: 0530h)

REGISTER DESCRIPTION	REGISTER	OFFSET
DMA channel 0 control	DMA0CTL	00h
DMA channel 0 source address low	DMA0SAL	02h
DMA channel 0 source address high	DMA0SAH	04h
DMA channel 0 destination address low	DMA0DAL	06h
DMA channel 0 destination address high	DMA0DAH	08h
DMA channel 0 transfer size	DMA0SZ	0Ah
DMA channel 1 control	DMA1CTL	00h
DMA channel 1 source address low	DMA1SAL	02h
DMA channel 1 source address high	DMA1SAH	04h
DMA channel 1 destination address low	DMA1DAL	06h
DMA channel 1 destination address high	DMA1DAH	08h
DMA channel 1 transfer size	DMA1SZ	0Ah
DMA channel 2 control	DMA2CTL	00h
DMA channel 2 source address low	DMA2SAL	02h
DMA channel 2 source address high	DMA2SAH	04h
DMA channel 2 destination address low	DMA2DAL	06h
DMA channel 2 destination address high	DMA2DAH	08h
DMA channel 2 transfer size	DMA2SZ	0Ah
DMA module control 0	DMACTL0	00h
DMA module control 1	DMACTL1	02h
DMA module control 2	DMACTL2	04h
DMA module control 3	DMACTL3	06h
DMA module control 4	DMACTL4	08h
DMA interrupt vector	DMAIV	0Eh

Table 42. USCI_A0 Registers (Base Address: 05C0h)

REGISTER DESCRIPTION	REGISTER	OFFSET
USCI control 1	UCA0CTL1	00h
USCI control 0	UCA0CTL0	01h
USCI baud rate 0	UCA0BR0	06h
USCI baud rate 1	UCA0BR1	07h
USCI modulation control	UCA0MCTL	08h
USCI status	UCA0STAT	0Ah
USCI receive buffer	UCA0RXBUF	0Ch
USCI transmit buffer	UCA0TXBUF	0Eh
USCI LIN control	UCA0ABCTL	10h
USCI IrDA transmit control	UCA0IRTCTL	12h
USCI IrDA receive control	UCA0IRRCTL	13h
USCI interrupt enable	UCA0IE	1Ch
USCI interrupt flags	UCA0IFG	1Dh
USCI interrupt vector word	UCA0IV	1Eh

Table 43. USCI_B0 Registers (Base Address: 05E0h)

REGISTER DESCRIPTION	REGISTER	OFFSET
USCI synchronous control 1	UCB0CTL1	00h
USCI synchronous control 0	UCB0CTL0	01h
USCI synchronous bit rate 0	UCB0BR0	06h
USCI synchronous bit rate 1	UCB0BR1	07h
USCI synchronous status	UCB0STAT	0Ah
USCI synchronous receive buffer	UCB0RXBUF	0Ch
USCI synchronous transmit buffer	UCB0TXBUF	0Eh
USCI I2C own address	UCB0I2COA	10h
USCI I2C slave address	UCB0I2CSA	12h
USCI interrupt enable	UCB0IE	1Ch
USCI interrupt flags	UCB0IFG	1Dh
USCI interrupt vector word	UCB0IV	1Eh

Table 44. USCI_A1 Registers (Base Address: 0600h)

REGISTER DESCRIPTION	REGISTER	OFFSET
USCI control 1	UCA1CTL1	00h
USCI control 0	UCA1CTL0	01h
USCI baud rate 0	UCA1BR0	06h
USCI baud rate 1	UCA1BR1	07h
USCI modulation control	UCA1MCTL	08h
USCI status	UCA1STAT	0Ah
USCI receive buffer	UCA1RXBUF	0Ch
USCI transmit buffer	UCA1TXBUF	0Eh
USCI LIN control	UCA1ABCTL	10h
USCI IrDA transmit control	UCA1IRTCTL	12h
USCI IrDA receive control	UCA1IRRCTL	13h
USCI interrupt enable	UCA1IE	1Ch
USCI interrupt flags	UCA1IFG	1Dh
USCI interrupt vector word	UCA1IV	1Eh

Table 45. USCI_B1 Registers (Base Address: 0620h)

REGISTER DESCRIPTION	REGISTER	OFFSET
USCI synchronous control 1	UCB1CTL1	00h
USCI synchronous control 0	UCB1CTL0	01h
USCI synchronous bit rate 0	UCB1BR0	06h
USCI synchronous bit rate 1	UCB1BR1	07h
USCI synchronous status	UCB1STAT	0Ah
USCI synchronous receive buffer	UCB1RXBUF	0Ch
USCI synchronous transmit buffer	UCB1TXBUF	0Eh
USCI I2C own address	UCB1I2COA	10h
USCI I2C slave address	UCB1I2CSA	12h
USCI interrupt enable	UCB1IE	1Ch
USCI interrupt flags	UCB1IFG	1Dh
USCI interrupt vector word	UCB1IV	1Eh

Table 46. USCI_A2 Registers (Base Address: 0640h)

REGISTER DESCRIPTION	REGISTER	OFFSET
USCI control 1	UCA2CTL1	00h
USCI control 0	UCA2CTL0	01h
USCI baud rate 0	UCA2BR0	06h
USCI baud rate 1	UCA2BR1	07h
USCI modulation control	UCA2MCTL	08h
USCI status	UCA2STAT	0Ah
USCI receive buffer	UCA2RXBUF	0Ch
USCI transmit buffer	UCA2TXBUF	0Eh
USCI LIN control	UCA2ABCTL	10h
USCI IrDA transmit control	UCA2IRTCTL	12h
USCI IrDA receive control	UCA2IRRCTL	13h
USCI interrupt enable	UCA2IE	1Ch
USCI interrupt flags	UCA2IFG	1Dh
USCI interrupt vector word	UCA2IV	1Eh

Table 47. USCI_B2 Registers (Base Address: 0660h)

REGISTER DESCRIPTION	REGISTER	OFFSET
USCI synchronous control 1	UCB2CTL1	00h
USCI synchronous control 0	UCB2CTL0	01h
USCI synchronous bit rate 0	UCB2BR0	06h
USCI synchronous bit rate 1	UCB2BR1	07h
USCI synchronous status	UCB2STAT	0Ah
USCI synchronous receive buffer	UCB2RXBUF	0Ch
USCI synchronous transmit buffer	UCB2TXBUF	0Eh
USCI I2C own address	UCB2I2COA	10h
USCI I2C slave address	UCB2I2CSA	12h
USCI interrupt enable	UCB2IE	1Ch
USCI interrupt flags	UCB2IFG	1Dh
USCI interrupt vector word	UCB2IV	1Eh

Table 48. USCI_A3 Registers (Base Address: 0680h)

REGISTER DESCRIPTION	REGISTER	OFFSET
USCI control 1	UCA3CTL1	00h
USCI control 0	UCA3CTL0	01h
USCI baud rate 0	UCA3BR0	06h
USCI baud rate 1	UCA3BR1	07h
USCI modulation control	UCA3MCTL	08h
USCI status	UCA3STAT	0Ah
USCI receive buffer	UCA3RXBUF	0Ch
USCI transmit buffer	UCA3TXBUF	0Eh
USCI LIN control	UCA3ABCTL	10h
USCI IrDA transmit control	UCA3IRTCTL	12h
USCI IrDA receive control	UCA3IRRCTL	13h
USCI interrupt enable	UCA3IE	1Ch
USCI interrupt flags	UCA3IFG	1Dh
USCI interrupt vector word	UCA3IV	1Eh

Table 49. USCI_B3 Registers (Base Address: 06A0h)

REGISTER DESCRIPTION	REGISTER	OFFSET
USCI synchronous control 1	UCB3CTL1	00h
USCI synchronous control 0	UCB3CTL0	01h
USCI synchronous bit rate 0	UCB3BR0	06h
USCI synchronous bit rate 1	UCB3BR1	07h
USCI synchronous status	UCB3STAT	0Ah
USCI synchronous receive buffer	UCB3RXBUF	0Ch
USCI synchronous transmit buffer	UCB3TXBUF	0Eh
USCI I2C own address	UCB3I2COA	10h
USCI I2C slave address	UCB3I2CSA	12h
USCI interrupt enable	UCB3IE	1Ch
USCI interrupt flags	UCB3IFG	1Dh
USCI interrupt vector word	UCB3IV	1Eh

Table 50. ADC10_A Registers (Base Address: 0740h)

REGISTER DESCRIPTION	REGISTER	OFFSET
ADC10_A Control register 0	ADC10CTL0	00h
ADC10_A Control register 1	ADC10CTL1	02h
ADC10_A Control register 2	ADC10CTL2	04h
ADC10_A Window Comparator Low Threshold	ADC10LO	06h
ADC10_A Window Comparator High Threshold	ADC10HI	08h
ADC10_A Memory Control Register 0	ADC10MCTL0	0Ah
ADC10_A Conversion Memory Register	ADC10MEM0	12h
ADC10_A Interrupt Enable	ADC10IE	1Ah
ADC10_A Interrupt Flags	ADC10IGH	1Ch
ADC10_A Interrupt Vector Word	ADC10IV	1Eh

Table 51. Comparator_B Registers (Base Address: 08C0h)

REGISTER DESCRIPTION	REGISTER	OFFSET
Comp_B control register 0	CBCTL0	00h
Comp_B control register 1	CBCTL1	02h
Comp_B control register 2	CBCTL2	04h
Comp_B control register 3	CBCTL3	06h
Comp_B interrupt register	CBINT	0Ch
Comp_B interrupt vector word	CBIV	0Eh

Absolute Maximum Ratings⁽¹⁾

over operating free-air temperature range (unless otherwise noted)

Voltage applied at V _{CC} to V _{SS}	-0.3 V to 4.1 V
Voltage applied at V _{IO} to V _{SS}	-0.3 V to 2.2 V
Voltage applied to any pin (excluding V _{CORE} and V _{IO} pins) ⁽²⁾	-0.3 V to V _{CC} + 0.3 V
Voltage applied to V _{IO} pins	-0.3 V to V _{IO} + 0.2 V
Diode current at any device pin	±2 mA
Storage temperature range, T _{stg} ⁽³⁾	-55°C to 150°C

- (1) Stresses beyond those listed under "absolute maximum ratings" may cause permanent damage to the device. These are stress ratings only, and functional operation of the device at these or any other conditions beyond those indicated under "recommended operating conditions" is not implied. Exposure to absolute-maximum-rated conditions for extended periods may affect device reliability.
- (2) All voltages referenced to V_{SS}. V_{CORE} is for internal device use only. No external DC loading or voltage should be applied.
- (3) Higher temperature may be applied during board soldering according to the current JEDEC J-STD-020 specification with peak reflow temperatures not higher than classified on the device label on the shipping boxes or reels.

Recommended Operating Conditions

Typical values are specified at V_{CC} = 3.3 V and T_A = 25°C (unless otherwise noted)

		MIN	NOM	MAX	UNIT
V _{CC}	Supply voltage during program execution and flash programming (AV _{CC} = DV _{CC}) ^{(1) (2) (3)}	PMMCOREVx = 0	1.8	3.6	V
		PMMCOREVx = 0, 1	2.0	3.6	V
		PMMCOREVx = 0, 1, 2	2.2	3.6	V
		PMMCOREVx = 0, 1, 2, 3	2.4	3.6	V
V _{IO}	Supply voltage applied to DVIO referenced to V _{SS} ⁽²⁾	1.62		1.98	V
V _{SS}	Supply voltage (AV _{SS} = DV _{SS})		0		V
T _A	Operating free-air temperature	-40		85	°C
T _J	Operating junction temperature	-40		85	°C
C _{VCORE}	Recommended capacitor at V _{CORE}		470		nF
C _{DVCC} / C _{VCORE}	Capacitor ratio of DVCC to V _{CORE}		10		
f _{SYSTEM}	Processor frequency (maximum MCLK frequency) ⁽⁴⁾ (see Figure 4)	PMMCOREVx = 0 (default condition), 1.8 V ≤ V _{CC} ≤ 3.6 V	0	8.0	MHz
		PMMCOREVx = 1, 2.0 V ≤ V _{CC} ≤ 3.6 V	0	12.0	
		PMMCOREVx = 2, 2.2 V ≤ V _{CC} ≤ 3.6 V	0	20.0	
		PMMCOREVx = 3, 2.4 V ≤ V _{CC} ≤ 3.6 V	0	25.0	

- (1) It is recommended to power AVCC and DVCC from the same source. A maximum difference of 0.3 V between AVCC and DVCC can be tolerated during power up and operation.
- (2) During V_{CC} and V_{IO} power up, it is required that V_{IO} ≥ V_{CC} during the ramp up phase of V_{IO}. During V_{CC} and V_{IO} power down, it is required that V_{IO} ≥ V_{CC} during the ramp down phase of V_{IO} (see Figure 2).
- (3) The minimum supply voltage is defined by the supervisor SVS levels when it is enabled. See the PMM, SVS High Side threshold parameters for the exact values and further details.
- (4) Modules may have a different maximum input clock specification. See the specification of the respective module in this data sheet.

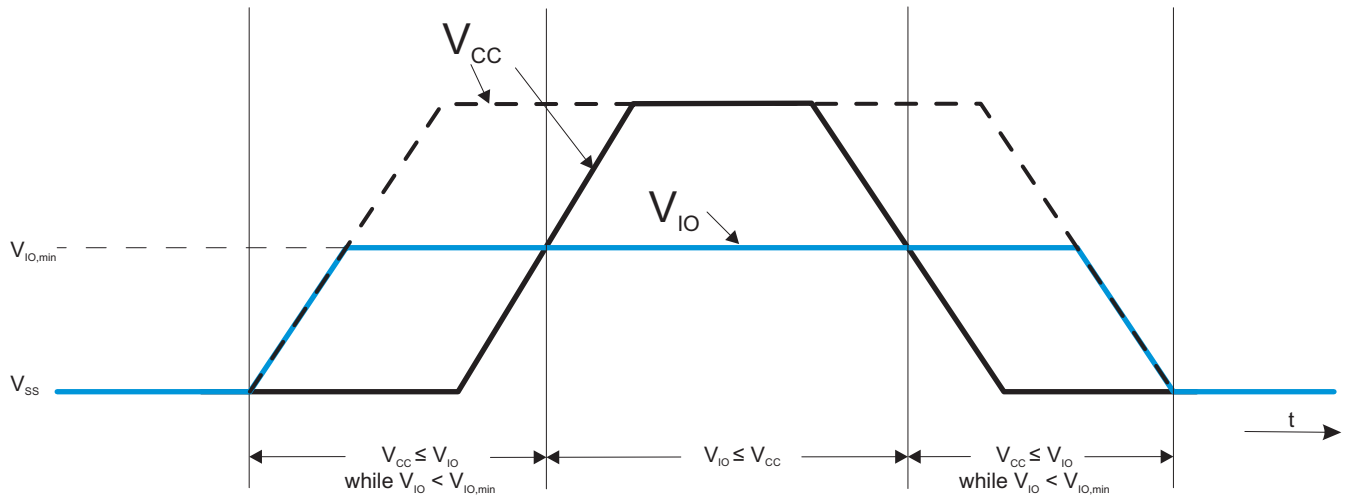

NOTE: The device supports continuous operation with $V_{CC} = V_{SS}$ while V_{IO} is fully within its specification. During this time, the general-purpose I/Os that reside on the V_{IO} supply domain are configured as inputs and pulled down to V_{SS} through their internal pulldown resistors. \overline{RST}/NMI is high impedance. $BSLEN$ is configured as an input and is pulled down to V_{SS} through its internal pulldown resistor. When V_{CC} rises above the BOR threshold, the general-purpose I/Os become high-impedance inputs (no pullup or pulldown enabled), \overline{RST}/NMI becomes an input pulled up to V_{IO} through its internal pullup resistor, and $BSLEN$ remains pulled down to V_{SS} through its internal pulldown resistor.

Figure 2. V_{CC} and V_{IO} Power Sequencing

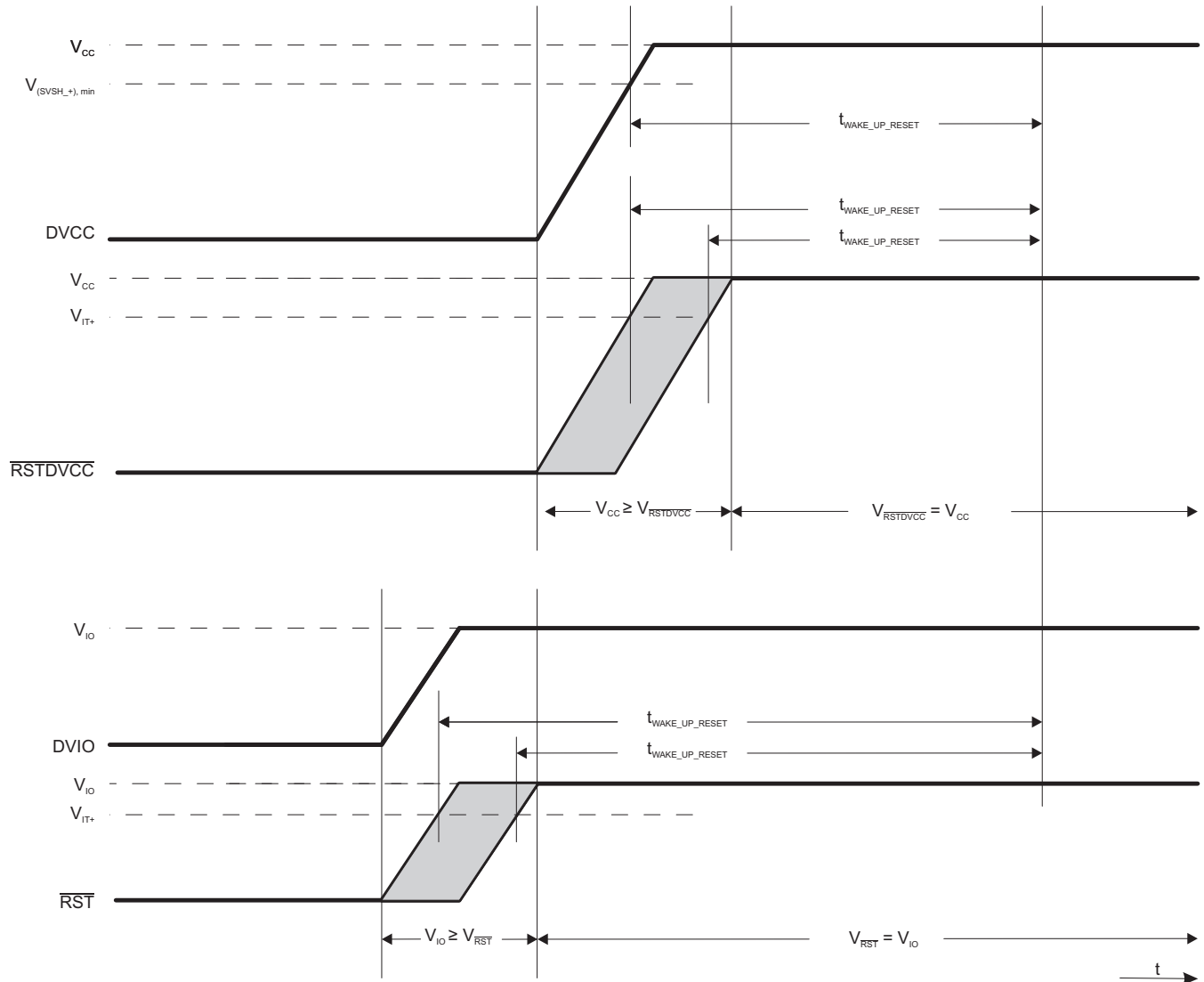

NOTE: The device remains in reset based on the conditions of the $\overline{RSTDVCC}$ and \overline{RST} pins and the voltage present on DVCC voltage supply. If $\overline{RSTDVCC}$ or \overline{RST} is held at a logic low or if DVCC is below the SVSH₊ minimum threshold, the device remains in its reset condition; that is, these conditions form a logical OR with respect to device reset.

Figure 3. Reset Timing

PRODUCT PREVIEW

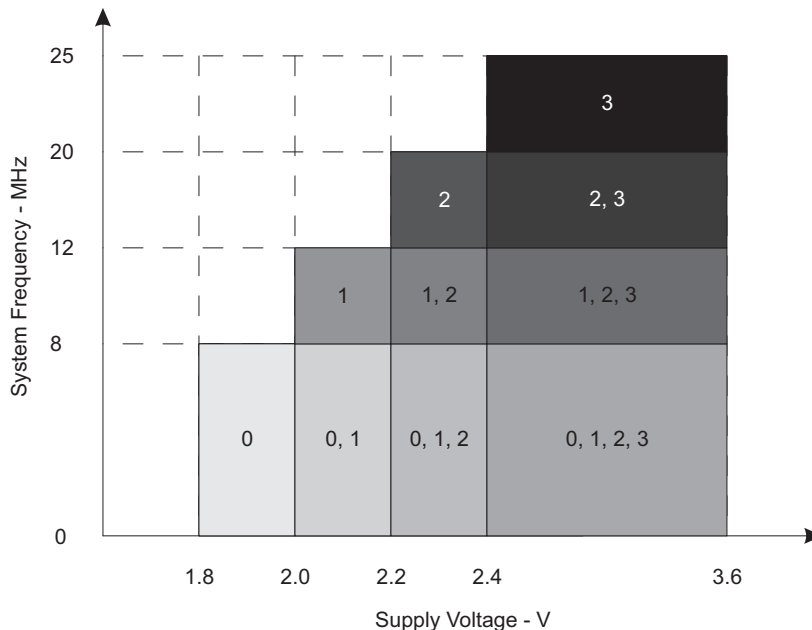

The numbers within the fields denote the supported PMMCOREVx settings.

Figure 4. Maximum System Frequency

Electrical Characteristics

Active Mode Supply Current Into V_{CC} Excluding External Current

over recommended operating free-air temperature (unless otherwise noted)⁽¹⁾ ⁽²⁾ ⁽³⁾

PARAMETER	EXECUTION MEMORY	V _{CC}	PMMCOREVx	FREQUENCY (f _{DCO} = f _{MCLK} = f _{SMCLK})										UNIT
				1 MHz		8 MHz		12 MHz		20 MHz		25 MHz		
				TYP	MAX	TYP	MAX	TYP	MAX	TYP	MAX	TYP	MAX	
I _{AM, Flash}	Flash	3.0 V	0	0.36	0.47	2.32	2.60							mA
			1	0.40		2.65		4.0	4.4					
			2	0.44		2.90		4.3		7.1	7.7			
			3	0.46		3.10		4.6		7.6		10.1	11.0	
I _{AM, RAM}	RAM	3.0 V	0	0.20	0.29	1.20	1.30							mA
			1	0.22		1.35		2.0	2.2					
			2	0.24		1.50		2.2		3.7	4.2			
			3	0.26		1.60		2.4		3.9		5.3	6.2	

- (1) All inputs are tied to 0 V or to V_{CC}. Outputs do not source or sink any current.
- (2) The currents are characterized with a Micro Crystal MS1V-T1K crystal with a load capacitance of 12.5 pF. The internal and external load capacitance are chosen to closely match the required 12.5 pF.
- (3) Characterized with program executing typical data processing.
f_{ACLK} = 32786 Hz, f_{DCO} = f_{MCLK} = f_{SMCLK} at specified frequency.
XTS = CPUOFF = SCG0 = SCG1 = OSCOFF = SMCLKOFF = 0.

Low-Power Mode Supply Currents (Into V_{CC}) Excluding External Current

over recommended ranges of supply voltage and operating free-air temperature (unless otherwise noted)^{(1) (2)}

PARAMETER	V_{CC}	PMMCOREVx	-40 °C		25 °C		60 °C		85 °C		UNIT
			TYP	MAX	TYP	MAX	TYP	MAX	TYP	MAX	
$I_{LPM0,1MHz}$ Low-power mode 0 ^{(3) (4)}	2.2 V	0	73		78	91	84		93	103	μA
	3.0 V	3	89		95	105	101		112	124	
I_{LPM2} Low-power mode 2 ^{(5) (4)}	2.2 V	0	6.7		6.7	12	10.6		13	29	μA
	3.0 V	3	7.2		7.2	13	11.6		14	30	
$I_{LPM3,XT1LF}$ Low-power mode 3, crystal mode ^{(6) (4)}	2.2 V	0	1.8		2.1		3.4		8.4		μA
		1	1.9		2.2		3.6		8.7		
		2	2.0		2.4		3.8		9.0		
	3.0 V	0	2.0		2.3	3.1	3.6		8.6	24	
		1	2.1		2.5		3.8		8.9		
		2	2.2		2.6		3.9		9.2		
$I_{LPM3,VLO}$ Low-power mode 3, VLO mode ^{(7) (4)}	3.0 V	3	2.3		2.7	4.1	4.0		9.2	25	
		0	1.3		1.6	2.9	2.6		8.5	24	
		1	1.3		1.6		2.8		8.8		
		2	1.4		1.7		2.9		9.2		
I_{LPM4} Low-power mode 4 ^{(8) (4)}	3.0 V	3	1.5		1.8	3.2	2.9		9.2	25	
		0	1.1		1.3	1.7	2.6		7.5	22	
		1	1.3		1.4		2.7		7.7		
		2	1.4		1.4		2.8		7.9		
$I_{LPM4.5}$ Low-power mode 4.5 ⁽⁹⁾	3.0 V		0.15		0.18	0.35	0.26		0.5	1.0	μA
I_{DVIO_START}	0 V		1.40		1.40	2.0	1.45		1.5	2.1	μA

- (1) All inputs are tied to 0 V or to V_{CC} . Outputs do not source or sink any current.
- (2) The currents are characterized with a Micro Crystal MS1V-T1K crystal with a load capacitance of 12.5 pF. The internal and external load capacitance are chosen to closely match the required 12.5 pF.
- (3) Current for the watchdog timer clocked by SMCLK included. ACLK = low frequency crystal operation (XTS = 0, XT1DRIVEx = 0). CPUOFF = 1, SCG0 = 0, SCG1 = 0, OSCOFF = 0 (LPM0); f_{ACLK} = 32768 Hz, f_{MCLK} = 0 MHz, f_{SMCLK} = f_{DCO} = 1 MHz
- (4) Current for brownout and high-side supervisor (SVSH) normal mode included. Low-side supervisor (SVSL) and low-side monitor (SVM_L) disabled. High-side monitor (SVM_H) disabled. RAM retention enabled.
- (5) Current for watchdog timer and RTC clocked by ACLK included. ACLK = low frequency crystal operation (XTS = 0, XT1DRIVEx = 0). CPUOFF = 1, SCG0 = 0, SCG1 = 1, OSCOFF = 0 (LPM2); f_{ACLK} = 32768 Hz, f_{MCLK} = 0 MHz, f_{SMCLK} = f_{DCO} = 0 MHz; DCO setting = 1 MHz operation, DCO bias generator enabled.)
- (6) Current for watchdog timer and RTC clocked by ACLK included. ACLK = low frequency crystal operation (XTS = 0, XT1DRIVEx = 0). CPUOFF = 1, SCG0 = 1, SCG1 = 1, OSCOFF = 0 (LPM3); f_{ACLK} = 32768 Hz, f_{MCLK} = f_{SMCLK} = f_{DCO} = 0 MHz
- (7) Current for watchdog timer and RTC clocked by ACLK included. ACLK = VLO. CPUOFF = 1, SCG0 = 1, SCG1 = 1, OSCOFF = 0 (LPM3); f_{ACLK} = f_{VLO} , f_{MCLK} = f_{SMCLK} = f_{DCO} = 0 MHz
- (8) CPUOFF = 1, SCG0 = 1, SCG1 = 1, OSCOFF = 1 (LPM4); f_{DCO} = f_{ACLK} = f_{MCLK} = f_{SMCLK} = 0 MHz
- (9) Internal regulator disabled. No data retention. CPUOFF = 1, SCG0 = 1, SCG1 = 1, OSCOFF = 1, PMMREGOFF = 1 (LPM4.5); f_{DCO} = f_{ACLK} = f_{MCLK} = f_{SMCLK} = 0 MHz

Schmitt-Trigger Inputs – General-Purpose I/O DVCC Domain⁽¹⁾ (P5.0 to P5.5, P6.0 to P6.7, PJ.0 to PJ.3, RSTDVCC)

over recommended ranges of supply voltage and operating free-air temperature (unless otherwise noted)

PARAMETER	TEST CONDITIONS	V _{CC}	MIN	TYP	MAX	UNIT
V _{IT+} Positive-going input threshold voltage		1.8 V	0.80		1.40	V
		3 V	1.50		2.10	
V _{IT-} Negative-going input threshold voltage		1.8 V	0.45		1.00	V
		3 V	0.75		1.65	
V _{hys} Input voltage hysteresis (V _{IT+} – V _{IT-})		1.8 V	0.3		0.8	V
		3 V	0.4		1.0	
R _{Pull} Pullup or pulldown resistor	For pullup: V _{IN} = V _{SS} , For pulldown: V _{IN} = V _{CC}		20	35	50	kΩ
C _I Input capacitance	V _{IN} = V _{SS} or V _{CC}			5		pF

(1) Same parametrics apply to clock input pin when crystal bypass mode is used on XT1 (XIN) or XT2 (XT2IN).

Schmitt-Trigger Inputs – General-Purpose I/O DVIO Domain (P1.0 to P1.7, P2.0 to P2.7, P3.0 to P3.4, P4.0 to P4.7, P7.0 to P7.5, $\overline{\text{RST/NMI}}$, BLEN)

over recommended ranges of supply voltage and operating free-air temperature (unless otherwise noted)

PARAMETER	TEST CONDITIONS	V _{IO}	MIN	TYP	MAX	UNIT
V _{IT+} Positive-going input threshold voltage	V _{CC} = 3.0 V	1.62 V	0.8		1.25	V
		1.98 V	1.1		1.40	
V _{IT-} Negative-going input threshold voltage	V _{CC} = 3.0 V	1.62 V	0.3		0.7	V
		1.98 V	0.5		1.0	
V _{hys} Input voltage hysteresis (V _{IT+} – V _{IT-})	V _{CC} = 3.0 V	1.62 V to 1.98 V	0.3		0.8	V
R _{Pull} Pullup or pulldown resistor	For pullup: V _{IN} = V _{SS} , For pulldown: V _{IN} = V _{IO}		20	35	50	kΩ
C _I Input capacitance	V _{IN} = V _{SS} or V _{IO}			5		pF

Inputs – Interrupts DVCC Domain Port P6 (P6.0 to P6.7)

over recommended ranges of supply voltage and operating free-air temperature (unless otherwise noted)

PARAMETER	TEST CONDITIONS	V _{CC}	MIN	MAX	UNIT
t _(int) External interrupt timing ⁽¹⁾	External trigger pulse duration to set interrupt flag	1.8 V, 3 V	20		ns

(1) An external signal sets the interrupt flag every time the minimum interrupt pulse duration t_(int) is met. It may be set by trigger signals shorter than t_(int).

Inputs – Interrupts DVIO Domain Ports P1 and P2 (P1.0 to P1.7, P2.0 to P2.7)

over recommended ranges of supply voltage and operating free-air temperature (unless otherwise noted)

PARAMETER	TEST CONDITIONS	V _{IO} ⁽¹⁾	MIN	MAX	UNIT
t _(int) External interrupt timing ⁽²⁾	External trigger pulse duration to set interrupt flag, V _{CC} = 1.8 V or 3.0 V	1.62 V to 1.98 V	20		ns

(1) In all test conditions, V_{IO} ≤ V_{CC}.

(2) An external signal sets the interrupt flag every time the minimum interrupt pulse duration t_(int) is met. It may be set by trigger signals shorter than t_(int).

Leakage Current – General-Purpose I/O DVCC Domain (P5.0 to P5.5, P6.0 to P6.7, PJ.0 to PJ.3)

over recommended ranges of supply voltage and operating free-air temperature (unless otherwise noted)

PARAMETER	TEST CONDITIONS	V _{CC}	MIN	MAX	UNIT
I _{lkg} (Px.y) High-impedance leakage current	See ⁽¹⁾⁽²⁾	1.8 V, 3 V	-50	50	nA

- (1) The leakage current is measured with V_{SS} or V_{CC} applied to the corresponding pins, unless otherwise noted.
- (2) The leakage of the digital port pins is measured individually. The port pin is selected for input and the pullup or pulldown resistor is disabled.

Leakage Current – General-Purpose I/O DVIO Domain (P1.0 to P1.7, P2.0 to P2.7, P3.0 to P3.4, P4.0 to P4.7, P7.0 to P7.5)

over recommended ranges of supply voltage and operating free-air temperature (unless otherwise noted)

PARAMETER	TEST CONDITIONS	V _{IO} ⁽¹⁾	MIN	MAX	UNIT
I _{lkg} (Px.y) High-impedance leakage current	See ⁽²⁾⁽³⁾	1.62 V to 1.98 V	-50	50	nA

- (1) In all test conditions, V_{IO} ≤ V_{CC}.
- (2) The leakage current is measured with V_{SS} or V_{IO} applied to the corresponding pins, unless otherwise noted.
- (3) The leakage of the digital port pins is measured individually. The port pin is selected for input and the pullup or pulldown resistor is disabled.

Outputs – General-Purpose I/O DVCC Domain (Full Drive Strength) (P5.0 to P5.5, P6.0 to P6.7, PJ.0 to PJ.3)

over recommended ranges of supply voltage and operating free-air temperature (unless otherwise noted)

PARAMETER	TEST CONDITIONS	V _{CC}	MIN	MAX	UNIT
V _{OH} High-level output voltage	I _(OHmax) = -3 mA ⁽¹⁾	1.8 V	V _{CC} - 0.25	V _{CC}	V
	I _(OHmax) = -10 mA ⁽²⁾		V _{CC} - 0.60	V _{CC}	
	I _(OHmax) = -5 mA ⁽¹⁾	3 V	V _{CC} - 0.25	V _{CC}	
			I _(OHmax) = -15 mA ⁽²⁾	V _{CC} - 0.60	
V _{OL} Low-level output voltage	I _(OLmax) = 3 mA ⁽¹⁾	1.8 V	V _{SS}	V _{SS} + 0.25	V
	I _(OLmax) = 10 mA ⁽²⁾		V _{SS}	V _{SS} + 0.60	
	I _(OLmax) = 5 mA ⁽¹⁾	3 V	V _{SS}	V _{SS} + 0.25	
			I _(OLmax) = 15 mA ⁽²⁾	V _{SS}	

- (1) The maximum total current, I_(OHmax) and I_(OLmax), for all outputs combined should not exceed ±48 mA to hold the maximum voltage drop specified.
- (2) The maximum total current, I_(OHmax) and I_(OLmax), for all outputs combined should not exceed ±100 mA to hold the maximum voltage drop specified.

Outputs – General-Purpose I/O DVCC Domain (Reduced Drive Strength) (P5.0 to P5.5, P6.0 to P6.7, PJ.0 to PJ.3)

over recommended ranges of supply voltage and operating free-air temperature (unless otherwise noted)⁽¹⁾

PARAMETER		TEST CONDITIONS	V _{CC}	MIN	MAX	UNIT
V _{OH}	High-level output voltage	I _(OHmax) = -1 mA ⁽²⁾	1.8 V	V _{CC} - 0.25	V _{CC}	V
		I _(OHmax) = -3 mA ⁽³⁾		V _{CC} - 0.60	V _{CC}	
		I _(OHmax) = -2 mA ⁽²⁾	3.0 V	V _{CC} - 0.25	V _{CC}	
		I _(OHmax) = -6 mA ⁽³⁾		V _{CC} - 0.60	V _{CC}	
V _{OL}	Low-level output voltage	I _(OLmax) = 1 mA ⁽²⁾	1.8 V	V _{SS}	V _{SS} + 0.25	V
		I _(OLmax) = 3 mA ⁽³⁾		V _{SS}	V _{SS} + 0.60	
		I _(OLmax) = 2 mA ⁽²⁾	3.0 V	V _{SS}	V _{SS} + 0.25	
		I _(OLmax) = 6 mA ⁽³⁾		V _{SS}	V _{SS} + 0.60	

- (1) Selecting reduced drive strength may reduce EMI.
- (2) The maximum total current, I_(OHmax) and I_(OLmax), for all outputs combined, should not exceed ±48 mA to hold the maximum voltage drop specified.
- (3) The maximum total current, I_(OHmax) and I_(OLmax), for all outputs combined, should not exceed ±100 mA to hold the maximum voltage drop specified.

Outputs – General-Purpose I/O DVIO Domain (Full Drive Strength) (P1.0 to P1.7, P2.0 to P2.7, P3.0 to P3.4, P4.0 to P4.7, P7.0 to P7.5)

over recommended ranges of supply voltage and operating free-air temperature (unless otherwise noted)

PARAMETER		TEST CONDITIONS	V _{IO} ⁽¹⁾	MIN	MAX	UNIT
V _{OH}	High-level output voltage	I _(OHmax) = -100 μA ⁽²⁾	1.62 V to 1.98 V	V _{IO} - 0.05	V _{IO}	V
		I _(OHmax) = -3 mA ⁽²⁾		V _{IO} - 0.25	V _{IO}	
		I _(OHmax) = -6 mA ⁽²⁾		V _{IO} - 0.50	V _{IO}	
V _{OL}	Low-level output voltage	I _(OLmax) = 3 mA ⁽²⁾	1.62 V to 1.98 V	V _{SS}	V _{SS} + 0.25	V
		I _(OLmax) = 6 mA ⁽²⁾		V _{SS}	V _{SS} + 0.50	

- (1) In all test conditions, V_{IO} ≤ V_{CC}.
- (2) The maximum total current, I_(OHmax) and I_(OLmax), for all outputs combined, should not exceed ±48 mA to hold the maximum voltage drop specified.

Outputs – General-Purpose I/O DVIO Domain (Reduced Drive Strength) (P1.0 to P1.7, P2.0 to P2.7, P3.0 to P3.4, P4.0 to P4.7, P7.0 to P7.5)

over recommended ranges of supply voltage and operating free-air temperature (unless otherwise noted)⁽¹⁾

PARAMETER		TEST CONDITIONS	V _{IO} ⁽²⁾	MIN	MAX	UNIT
V _{OH}	High-level output voltage	I _(OHmax) = -100 μA ⁽³⁾	1.62 V to 1.98 V	V _{IO} - 0.05	V _{IO}	V
		I _(OHmax) = -1 mA ⁽³⁾		V _{IO} - 0.25	V _{IO}	
		I _(OHmax) = -2 mA ⁽³⁾		V _{IO} - 0.50	V _{IO}	
V _{OL}	Low-level output voltage	I _(OLmax) = 1 mA ⁽³⁾	1.62 V to 1.98 V	V _{SS}	V _{SS} + 0.25	V
		I _(OLmax) = 2 mA ⁽³⁾		V _{SS}	V _{SS} + 0.50	

- (1) Selecting reduced drive strength may reduce EMI.
- (2) In all test conditions, V_{IO} ≤ V_{CC}.
- (3) The maximum total current, I_(OHmax) and I_(OLmax), for all outputs combined, should not exceed ±48 mA to hold the maximum voltage drop specified.

Output Frequency – General-Purpose I/O DVCC Domain (P5.0 to P5.5, P6.0 to P6.7, PJ.0 to PJ.3)

over recommended ranges of supply voltage and operating free-air temperature (unless otherwise noted)

PARAMETER		TEST CONDITIONS	MIN	MAX	UNIT
f _{Px.y}	Port output frequency (with load)	(1)(2)V _{CC} = 1.8 V, PMMCOREVx = 0		16	MHz
		V _{CC} = 3 V, PMMCOREVx = 3		25	
f _{Port_CLK}	Clock output frequency	ACLK, SMCLK, or MCLK, C _L = 20 pF ⁽²⁾	V _{CC} = 1.8 V, PMMCOREVx = 0		16
			V _{CC} = 3 V, PMMCOREVx = 3		25

- (1) A resistive divider with 2 × R1 between V_{CC} and V_{SS} is used as load. The output is connected to the center tap of the divider. For full drive strength, R1 = 550 Ω. For reduced drive strength, R1 = 1.6 kΩ. C_L = 20 pF is connected to the output to V_{SS}.
- (2) The output voltage reaches at least 10% and 90% V_{CC} at the specified toggle frequency.

Output Frequency – General-Purpose I/O DVIO Domain (P1.0 to P1.7, P2.0 to P2.7, P3.0 to P3.4, P4.0 to P4.7, P7.0 to P7.5)

over recommended ranges of supply voltage and operating free-air temperature (unless otherwise noted)

PARAMETER		TEST CONDITIONS	MIN	MAX	UNIT
f _{Px.y}	Port output frequency (with load)	(1)(2)V _{IO} = 1.62 V to 1.98 V ⁽³⁾ , PMMCOREVx = 0		16	MHz
		V _{IO} = 1.62 V to 1.98 V ⁽³⁾ , PMMCOREVx = 3		25	
f _{Port_CLK}	Clock output frequency	ACLK, SMCLK, or MCLK, C _L = 20 pF ⁽²⁾	V _{IO} = 1.62 V to 1.98 V ⁽³⁾ , PMMCOREVx = 0		16
			V _{IO} = 1.62 V to 1.98 V ⁽³⁾ , PMMCOREVx = 3		25

- (1) A resistive divider with 2 × R1 between V_{IO} and V_{SS} is used as load. The output is connected to the center tap of the divider. For full drive strength, R1 = 550 Ω. For reduced drive strength, R1 = 1.6 kΩ. C_L = 20 pF is connected to the output to V_{SS}.
- (2) The output voltage reaches at least 10% and 90% V_{IO} at the specified toggle frequency.
- (3) In all test conditions, V_{IO} ≤ V_{CC}.

Typical Characteristics – Outputs, Reduced Drive Strength (PxDS.y = 0)

over recommended ranges of supply voltage and operating free-air temperature (unless otherwise noted)

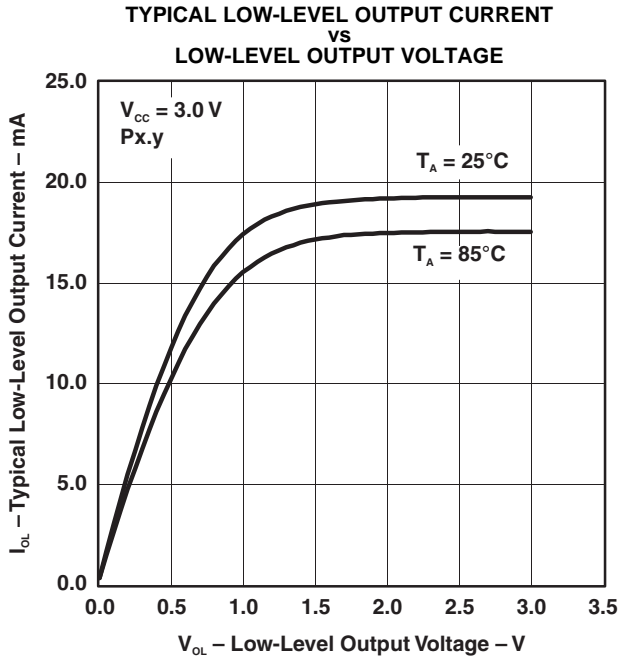

Figure 5.

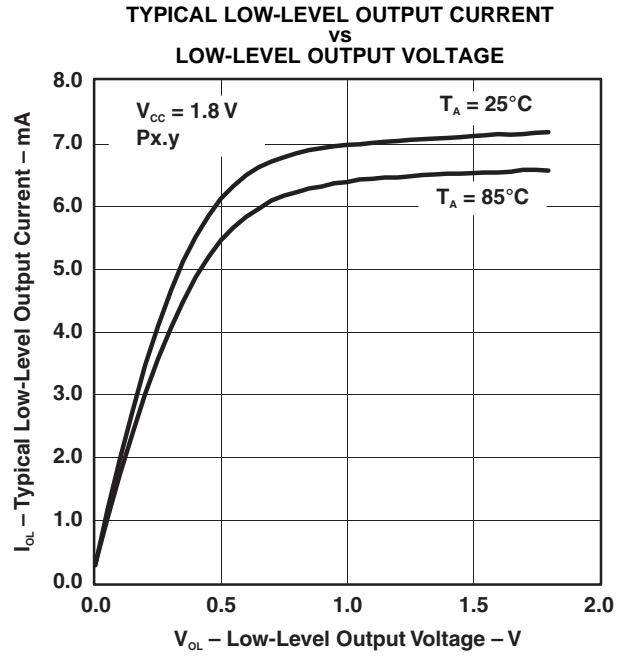

Figure 6.

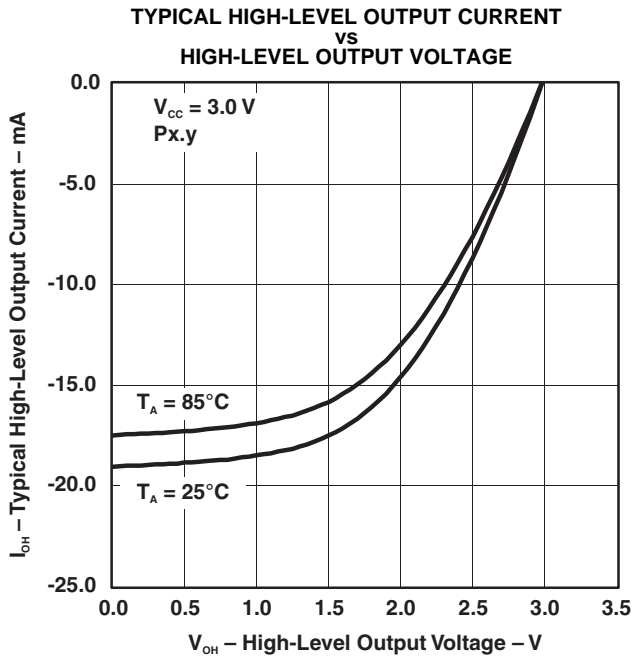

Figure 7.

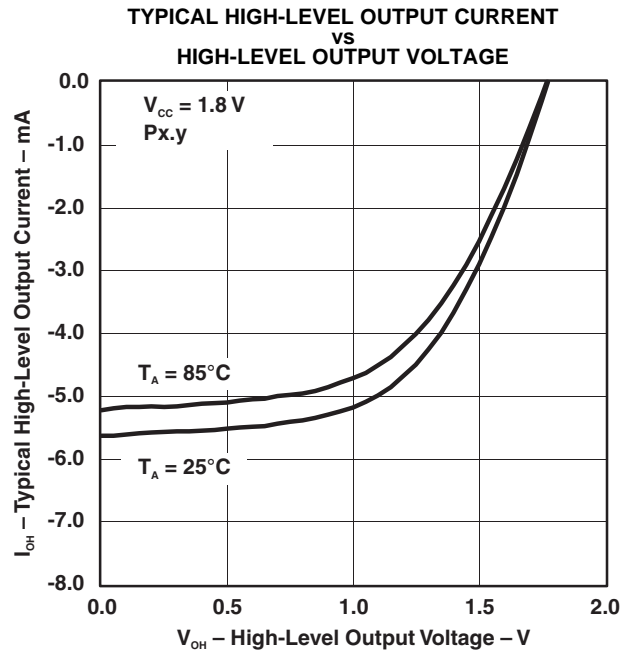

Figure 8.

PRODUCT PREVIEW

Typical Characteristics – Outputs, Full Drive Strength (PxDS.y = 1)

over recommended ranges of supply voltage and operating free-air temperature (unless otherwise noted)

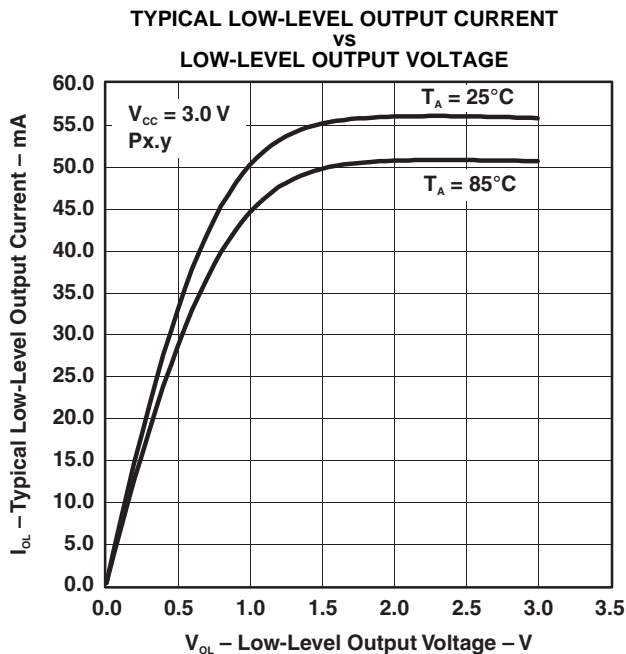

Figure 9.

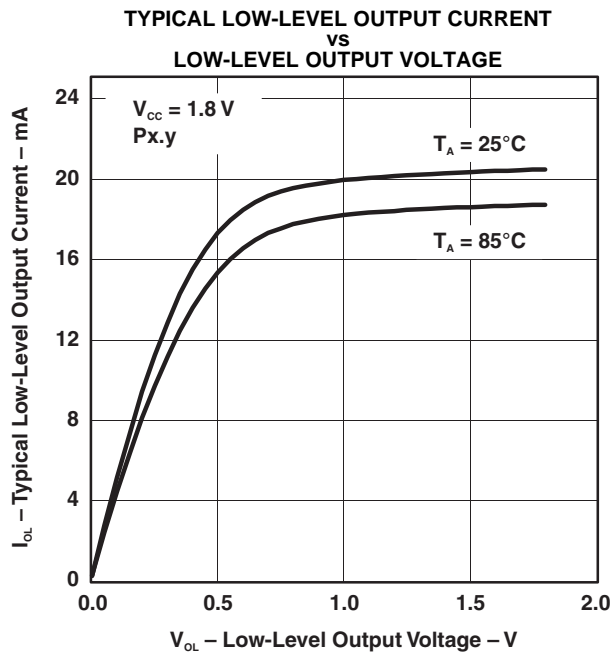

Figure 10.

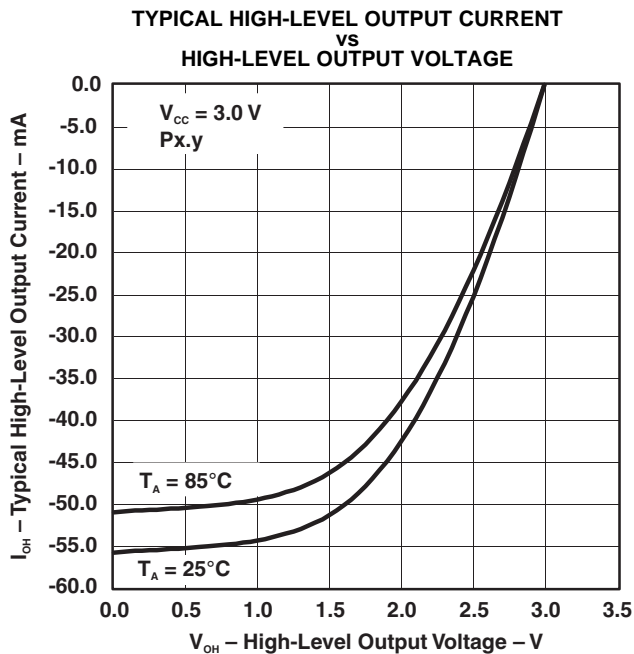

Figure 11.

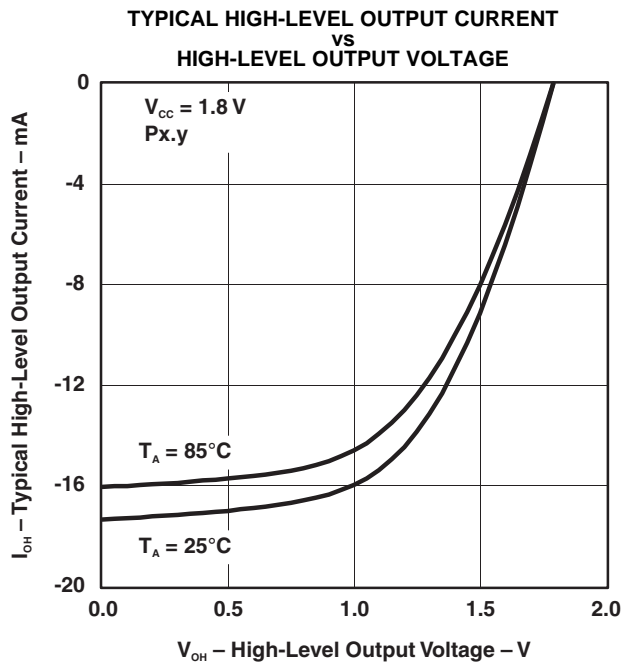

Figure 12.

PRODUCT PREVIEW

Crystal Oscillator, XT1, Low-Frequency Mode⁽¹⁾

over recommended ranges of supply voltage and operating free-air temperature (unless otherwise noted)

PARAMETER		TEST CONDITIONS	V _{CC}	MIN	TYP	MAX	UNIT
$\Delta I_{DVCC,LF}$	Differential XT1 oscillator crystal current consumption from lowest drive setting, LF mode	$f_{OSC} = 32768$ Hz, XTS = 0, XT1BYPASS = 0, XT1DRIVE _x = 1, T _A = 25°C	3.0 V	0.075			μA
		$f_{OSC} = 32768$ Hz, XTS = 0, XT1BYPASS = 0, XT1DRIVE _x = 2, T _A = 25°C		0.170			
		$f_{OSC} = 32768$ Hz, XTS = 0, XT1BYPASS = 0, XT1DRIVE _x = 3, T _A = 25°C		0.290			
$f_{XT1,LF0}$	XT1 oscillator crystal frequency, LF mode	XTS = 0, XT1BYPASS = 0		32768			Hz
$f_{XT1,LF,SW}$	XT1 oscillator logic-level square-wave input frequency, LF mode	XTS = 0, XT1BYPASS = 1 ⁽²⁾ ⁽³⁾ XT1BYPASSLV = 0 or 1		10	32.768	50	kHz
OA_{LF}	Oscillation allowance for LF crystals ⁽⁴⁾	XTS = 0, XT1BYPASS = 0, XT1DRIVE _x = 0, $f_{XT1,LF} = 32768$ Hz, C _{L,eff} = 6 pF		210			kΩ
		XTS = 0, XT1BYPASS = 0, XT1DRIVE _x = 1, $f_{XT1,LF} = 32768$ Hz, C _{L,eff} = 12 pF		300			
$C_{L,eff}$	Integrated effective load capacitance, LF mode ⁽⁵⁾	XTS = 0, XCAP _x = 0 ⁽⁶⁾		2			pF
		XTS = 0, XCAP _x = 1		5.5			
		XTS = 0, XCAP _x = 2		8.5			
		XTS = 0, XCAP _x = 3		12.0			
	Duty cycle, LF mode	XTS = 0, Measured at ACLK, $f_{XT1,LF} = 32768$ Hz		30		70	%
$f_{Fault,LF}$	Oscillator fault frequency, LF mode ⁽⁷⁾	XTS = 0, XT1BYPASS = 1 ⁽⁸⁾ , XT1BYPASSLV = 0 or 1		10		10000	Hz

- (1) To improve EMI on the XT1 oscillator, the following guidelines should be observed.
 - (a) Keep the trace between the device and the crystal as short as possible.
 - (b) Design a good ground plane around the oscillator pins.
 - (c) Prevent crosstalk from other clock or data lines into oscillator pins XIN and XOUT.
 - (d) Avoid running PCB traces underneath or adjacent to the XIN and XOUT pins.
 - (e) Use assembly materials and techniques that avoid any parasitic load on the oscillator XIN and XOUT pins.
 - (f) If conformal coating is used, make sure that it does not induce capacitive or resistive leakage between the oscillator pins.
- (2) When XT1BYPASS is set, XT1 circuits are automatically powered down. Input signal is a digital square wave with parametrics defined in the Schmitt-Trigger Inputs section of this datasheet. When in crystal bypass mode, XIN can be configured so that it can support an input digital waveform with swing levels from DVSS to DVCC (XT1BYPASSLV = 0) or DVSS to DVIO (XT1BYPASSLV = 1). In this case, it is required that the pin be configured properly for the intended input swing.
- (3) Maximum frequency of operation of the entire device cannot be exceeded.
- (4) Oscillation allowance is based on a safety factor of 5 for recommended crystals. The oscillation allowance is a function of the XT1DRIVE_x settings and the effective load. In general, comparable oscillator allowance can be achieved based on the following guidelines, but each application should be evaluated based on the actual crystal selected:
 - (a) For XT1DRIVE_x = 0, C_{L,eff} ≤ 6 pF
 - (b) For XT1DRIVE_x = 1, 6 pF ≤ C_{L,eff} ≤ 9 pF
 - (c) For XT1DRIVE_x = 2, 6 pF ≤ C_{L,eff} ≤ 10 pF
 - (d) For XT1DRIVE_x = 3, C_{L,eff} ≥ 6 pF
- (5) Includes parasitic bond and package capacitance (approximately 2 pF per pin).
Because the PCB adds additional capacitance, it is recommended to verify the correct load by measuring the ACLK frequency. For a correct setup, the effective load capacitance should always match the specification of the used crystal.
- (6) Requires external capacitors at both terminals. Values are specified by crystal manufacturers.
- (7) Frequencies below the MIN specification set the fault flag. Frequencies above the MAX specification do not set the fault flag. Frequencies in between might set the flag.
- (8) Measured with logic-level input frequency but also applies to operation with crystals.

Crystal Oscillator, XT1, Low-Frequency Mode⁽¹⁾ (continued)

over recommended ranges of supply voltage and operating free-air temperature (unless otherwise noted)

PARAMETER	TEST CONDITIONS	V _{CC}	MIN	TYP	MAX	UNIT
t _{START,LF} Startup time, LF mode	f _{OSC} = 32768 Hz, XTS = 0, XT1BYPASS = 0, XT1DRIVE _x = 0, T _A = 25°C, C _{L,eff} = 6 pF	3.0 V		1000		ms
	f _{OSC} = 32768 Hz, XTS = 0, XT1BYPASS = 0, XT1DRIVE _x = 3, T _A = 25°C, C _{L,eff} = 12 pF			500		

Crystal Oscillator, XT2

over recommended ranges of supply voltage and operating free-air temperature (unless otherwise noted)^{(1) (2)}

PARAMETER	TEST CONDITIONS	V _{CC}	MIN	TYP	MAX	UNIT
I _{DVCC,XT2} XT2 oscillator crystal current consumption	f _{OSC} = 4 MHz, XT2OFF = 0, XT2BYPASS = 0, XT2DRIVE _x = 0, T _A = 25°C	3.0 V		200		μA
	f _{OSC} = 12 MHz, XT2OFF = 0, XT2BYPASS = 0, XT2DRIVE _x = 1, T _A = 25°C			260		
	f _{OSC} = 20 MHz, XT2OFF = 0, XT2BYPASS = 0, XT2DRIVE _x = 2, T _A = 25°C			325		
	f _{OSC} = 32 MHz, XT2OFF = 0, XT2BYPASS = 0, XT2DRIVE _x = 3, T _A = 25°C			450		
f _{XT2,HF0} XT2 oscillator crystal frequency, mode 0	XT2DRIVE _x = 0, XT2BYPASS = 0 ⁽³⁾		4		8	MHz
f _{XT2,HF1} XT2 oscillator crystal frequency, mode 1	XT2DRIVE _x = 1, XT2BYPASS = 0 ⁽³⁾		8		16	MHz
f _{XT2,HF2} XT2 oscillator crystal frequency, mode 2	XT2DRIVE _x = 2, XT2BYPASS = 0 ⁽³⁾		16		24	MHz
f _{XT2,HF3} XT2 oscillator crystal frequency, mode 3	XT2DRIVE _x = 3, XT2BYPASS = 0 ⁽³⁾		24		32	MHz
f _{XT2,HF_SW} XT2 oscillator logic-level square-wave input frequency, bypass mode	XT2BYPASS = 1 ^{(4) (3)} XT2BYPASSLV = 0 or 1		0.7		32	MHz
O _{AHF} Oscillation allowance for HF crystals ⁽⁵⁾	XT2DRIVE _x = 0, XT2BYPASS = 0, f _{XT2,HF0} = 6 MHz, C _{L,eff} = 15 pF			450		Ω
	XT2DRIVE _x = 1, XT2BYPASS = 0, f _{XT2,HF1} = 12 MHz, C _{L,eff} = 15 pF			320		
	XT2DRIVE _x = 2, XT2BYPASS = 0, f _{XT2,HF2} = 20 MHz, C _{L,eff} = 15 pF			200		
	XT2DRIVE _x = 3, XT2BYPASS = 0, f _{XT2,HF3} = 32 MHz, C _{L,eff} = 15 pF			200		

- (1) Requires external capacitors at both terminals. Values are specified by crystal manufacturers.
- (2) To improve EMI on the XT2 oscillator the following guidelines should be observed.
 - (a) Keep the traces between the device and the crystal as short as possible.
 - (b) Design a good ground plane around the oscillator pins.
 - (c) Prevent crosstalk from other clock or data lines into oscillator pins XT2IN and XT2OUT.
 - (d) Avoid running PCB traces underneath or adjacent to the XT2IN and XT2OUT pins.
 - (e) Use assembly materials and techniques that avoid any parasitic load on the oscillator XT2IN and XT2OUT pins.
 - (f) If conformal coating is used, make sure that it does not induce capacitive or resistive leakage between the oscillator pins.
- (3) This represents the maximum frequency that can be input to the device externally. Maximum frequency achievable on the device operation is based on the frequencies present on ACLK, MCLK, and SMCLK cannot be exceed for a given range of operation.
- (4) When XT2BYPASS is set, the XT2 circuit is automatically powered down. Input signal is a digital square wave with parametrics defined in the Schmitt-trigger Inputs section of this datasheet. When in crystal bypass mode, XT2IN can be configured so that it can support an input digital waveform with swing levels from DVSS to DVCC (XT2BYPASSLV = 0) or DVSS to DVIO (XT2BYPASSLV = 1). In this case, it is required that the pin be configured properly for the intended input swing.
- (5) Oscillation allowance is based on a safety factor of 5 for recommended crystals.

Crystal Oscillator, XT2 (continued)

over recommended ranges of supply voltage and operating free-air temperature (unless otherwise noted)^{(1) (2)}

PARAMETER		TEST CONDITIONS	V _{CC}	MIN	TYP	MAX	UNIT
t _{START, HF}	Startup time	f _{OSC} = 6 MHz, XT2BYPASS = 0, XT2DRIVE _x = 0, T _A = 25°C, C _{L, eff} = 15 pF	3.0 V	0.5			ms
		f _{OSC} = 20 MHz, XT2BYPASS = 0, XT2DRIVE _x = 2, T _A = 25°C, C _{L, eff} = 15 pF		0.3			
C _{L, eff}	Integrated effective load capacitance, HF mode ^{(6) (1)}			1			pF
	Duty cycle	Measured at ACLK, f _{XT2, HF2} = 20 MHz		40	50	60	%
f _{Fault, HF}	Oscillator fault frequency ⁽⁷⁾	XT2BYPASS = 1 ⁽⁸⁾ , XT2BYPASSLV = 0 or 1		30		300	kHz

(6) Includes parasitic bond and package capacitance (approximately 2 pF per pin).

Because the PCB adds additional capacitance, it is recommended to verify the correct load by measuring the ACLK frequency. For a correct setup, the effective load capacitance should always match the specification of the used crystal.

(7) Frequencies below the MIN specification set the fault flag. Frequencies above the MAX specification do not set the fault flag. Frequencies in between might set the flag.

(8) Measured with logic-level input frequency but also applies to operation with crystals. Typically, an effective load capacitance of up to 18 pF can be supported.

Internal Very-Low-Power Low-Frequency Oscillator (VLO)

over recommended ranges of supply voltage and operating free-air temperature (unless otherwise noted)

PARAMETER		TEST CONDITIONS	V _{CC}	MIN	TYP	MAX	UNIT
f _{VLO}	VLO frequency	Measured at ACLK	1.8 V to 3.6 V	6	9.4	14	kHz
df _{VLO} /dT	VLO frequency temperature drift	Measured at ACLK ⁽¹⁾	1.8 V to 3.6 V	0.5			%/°C
df _{VLO} /dV _{CC}	VLO frequency supply voltage drift	Measured at ACLK ⁽²⁾	1.8 V to 3.6 V	4			%/V
	Duty cycle	Measured at ACLK	1.8 V to 3.6 V	40	50	60	%

(1) Calculated using the box method: (MAX(-40 to 85°C) – MIN(-40 to 85°C)) / MIN(-40 to 85°C) / (85°C – (-40°C))

(2) Calculated using the box method: (MAX(1.8 to 3.6 V) – MIN(1.8 to 3.6 V)) / MIN(1.8 to 3.6 V) / (3.6 V – 1.8 V)

Internal Reference, Low-Frequency Oscillator (REFO)

over recommended ranges of supply voltage and operating free-air temperature (unless otherwise noted)

PARAMETER		TEST CONDITIONS	V _{CC}	MIN	TYP	MAX	UNIT
I _{REFO}	REFO oscillator current consumption	T _A = 25°C	1.8 V to 3.6 V	3			μA
f _{REFO}	REFO frequency calibrated	Measured at ACLK	1.8 V to 3.6 V	32768			Hz
	REFO absolute tolerance calibrated	Full temperature range	1.8 V to 3.6 V	-3.5		3.5	%
		T _A = 25°C	3 V	-1.5		1.5	%
df _{REFO} /dT	REFO frequency temperature drift	Measured at ACLK ⁽¹⁾	1.8 V to 3.6 V	0.01			%/°C
df _{REFO} /dV _{CC}	REFO frequency supply voltage drift	Measured at ACLK ⁽²⁾	1.8 V to 3.6 V	1.0			%/V
	Duty cycle	Measured at ACLK	1.8 V to 3.6 V	40	50	60	%
t _{START}	REFO startup time	40%/60% duty cycle	1.8 V to 3.6 V	25			μs

(1) Calculated using the box method: (MAX(-40 to 85°C) – MIN(-40 to 85°C)) / MIN(-40 to 85°C) / (85°C – (-40°C))

(2) Calculated using the box method: (MAX(1.8 to 3.6 V) – MIN(1.8 to 3.6 V)) / MIN(1.8 to 3.6 V) / (3.6 V – 1.8 V)

DCO Frequency

over recommended ranges of supply voltage and operating free-air temperature (unless otherwise noted)

PARAMETER	TEST CONDITIONS	MIN	TYP	MAX	UNIT	
$f_{DCO(0,0)}$	DCO frequency (0, 0) ⁽¹⁾	DCORSELx = 0, DCOx = 0, MODx = 0	0.07	0.20	MHz	
$f_{DCO(0,31)}$	DCO frequency (0, 31) ⁽¹⁾	DCORSELx = 0, DCOx = 31, MODx = 0	0.70	1.70	MHz	
$f_{DCO(1,0)}$	DCO frequency (1, 0) ⁽¹⁾	DCORSELx = 1, DCOx = 0, MODx = 0	0.15	0.36	MHz	
$f_{DCO(1,31)}$	DCO frequency (1, 31) ⁽¹⁾	DCORSELx = 1, DCOx = 31, MODx = 0	1.47	3.45	MHz	
$f_{DCO(2,0)}$	DCO frequency (2, 0) ⁽¹⁾	DCORSELx = 2, DCOx = 0, MODx = 0	0.32	0.75	MHz	
$f_{DCO(2,31)}$	DCO frequency (2, 31) ⁽¹⁾	DCORSELx = 2, DCOx = 31, MODx = 0	3.17	7.38	MHz	
$f_{DCO(3,0)}$	DCO frequency (3, 0) ⁽¹⁾	DCORSELx = 3, DCOx = 0, MODx = 0	0.64	1.51	MHz	
$f_{DCO(3,31)}$	DCO frequency (3, 31) ⁽¹⁾	DCORSELx = 3, DCOx = 31, MODx = 0	6.07	14.0	MHz	
$f_{DCO(4,0)}$	DCO frequency (4, 0) ⁽¹⁾	DCORSELx = 4, DCOx = 0, MODx = 0	1.3	3.2	MHz	
$f_{DCO(4,31)}$	DCO frequency (4, 31) ⁽¹⁾	DCORSELx = 4, DCOx = 31, MODx = 0	12.3	28.2	MHz	
$f_{DCO(5,0)}$	DCO frequency (5, 0) ⁽¹⁾	DCORSELx = 5, DCOx = 0, MODx = 0	2.5	6.0	MHz	
$f_{DCO(5,31)}$	DCO frequency (5, 31) ⁽¹⁾	DCORSELx = 5, DCOx = 31, MODx = 0	23.7	54.1	MHz	
$f_{DCO(6,0)}$	DCO frequency (6, 0) ⁽¹⁾	DCORSELx = 6, DCOx = 0, MODx = 0	4.6	10.7	MHz	
$f_{DCO(6,31)}$	DCO frequency (6, 31) ⁽¹⁾	DCORSELx = 6, DCOx = 31, MODx = 0	39.0	88.0	MHz	
$f_{DCO(7,0)}$	DCO frequency (7, 0) ⁽¹⁾	DCORSELx = 7, DCOx = 0, MODx = 0	8.5	19.6	MHz	
$f_{DCO(7,31)}$	DCO frequency (7, 31) ⁽¹⁾	DCORSELx = 7, DCOx = 31, MODx = 0	60	135	MHz	
$S_{DCORSEL}$	Frequency step between range DCORSEL and DCORSEL + 1	$S_{RSEL} = f_{DCO(DCORSEL+1,DCO)}/f_{DCO(DCORSEL,DCO)}$	1.2	2.3	ratio	
S_{DCO}	Frequency step between tap DCO and DCO + 1	$S_{DCO} = f_{DCO(DCORSEL,DCO+1)}/f_{DCO(DCORSEL,DCO)}$	1.02	1.12	ratio	
	Duty cycle	Measured at SMCLK	40	50	60	%
df_{DCO}/dT	DCO frequency temperature drift ⁽²⁾	$f_{DCO} = 1$ MHz		0.1		%/°C
df_{DCO}/dV_{CC}	DCO frequency voltage drift ⁽³⁾	$f_{DCO} = 1$ MHz		1.9		%/V

- (1) When selecting the proper DCO frequency range (DCORSELx), the target DCO frequency, f_{DCO} , should be set to reside within the range of $f_{DCO(n,0),MAX} \leq f_{DCO} \leq f_{DCO(n,31),MIN}$, where $f_{DCO(n,0),MAX}$ represents the maximum frequency specified for the DCO frequency, range n, tap 0 (DCOx = 0) and $f_{DCO(n,31),MIN}$ represents the minimum frequency specified for the DCO frequency, range n, tap 31 (DCOx = 31). This ensures that the target DCO frequency resides within the range selected. It should also be noted that if the actual f_{DCO} frequency for the selected range causes the FLL or the application to select tap 0 or 31, the DCO fault flag is set to report that the selected range is at its minimum or maximum tap setting.
- (2) Calculated using the box method: $(MAX(-40 \text{ to } 85^\circ\text{C}) - MIN(-40 \text{ to } 85^\circ\text{C})) / MIN(-40 \text{ to } 85^\circ\text{C}) / (85^\circ\text{C} - (-40^\circ\text{C}))$
- (3) Calculated using the box method: $(MAX(1.8 \text{ to } 3.6 \text{ V}) - MIN(1.8 \text{ to } 3.6 \text{ V})) / MIN(1.8 \text{ to } 3.6 \text{ V}) / (3.6 \text{ V} - 1.8 \text{ V})$

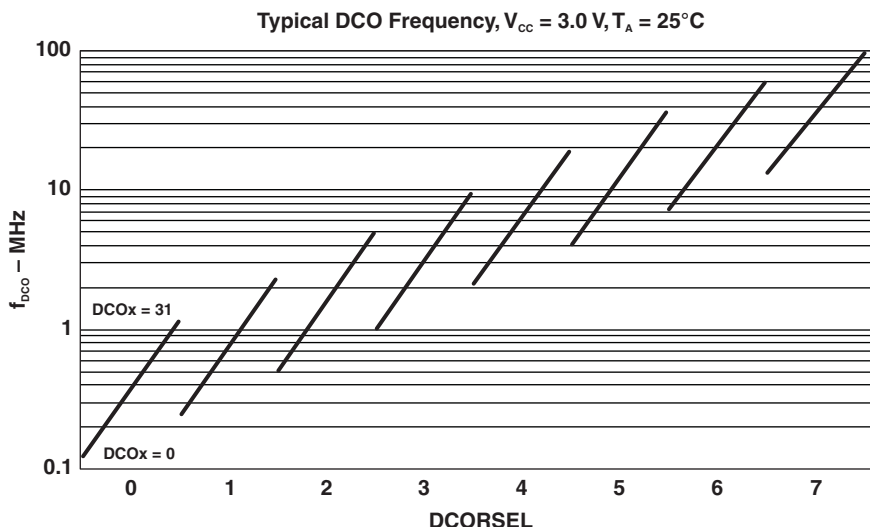

Figure 13. Typical DCO frequency

PMM, Brown-Out Reset (BOR)

over recommended ranges of supply voltage and operating free-air temperature (unless otherwise noted)

PARAMETER		TEST CONDITIONS	MIN	TYP	MAX	UNIT
V _{DVCC_BOR_IT-}	BOR _H on voltage, DV _{CC} falling level	dDV _{CC} /dt < 3 V/s			1.45	V
V _{DVCC_BOR_IT+}	BOR _H off voltage, DV _{CC} rising level	dDV _{CC} /dt < 3 V/s	0.80	1.30	1.50	V
V _{DVCC_BOR_hys}	BOR _H hysteresis		60		250	mV
t _{RESET}	Pulse duration required at $\overline{\text{RST}}$ /NMI pin to accept a reset		2			μs

PMM, Core Voltage

over recommended ranges of supply voltage and operating free-air temperature (unless otherwise noted)

PARAMETER		TEST CONDITIONS	MIN	TYP	MAX	UNIT
V _{CORE3(AM)}	Core voltage, active mode, PMMCOREV = 3	2.4 V ≤ DV _{CC} ≤ 3.6 V		1.90		V
V _{CORE2(AM)}	Core voltage, active mode, PMMCOREV = 2	2.2 V ≤ DV _{CC} ≤ 3.6 V		1.80		V
V _{CORE1(AM)}	Core voltage, active mode, PMMCOREV = 1	2.0 V ≤ DV _{CC} ≤ 3.6 V		1.60		V
V _{CORE0(AM)}	Core voltage, active mode, PMMCOREV = 0	1.8 V ≤ DV _{CC} ≤ 3.6 V		1.40		V
V _{CORE3(LPM)}	Core voltage, low-current mode, PMMCOREV = 3	2.4 V ≤ DV _{CC} ≤ 3.6 V		1.94		V
V _{CORE2(LPM)}	Core voltage, low-current mode, PMMCOREV = 2	2.2 V ≤ DV _{CC} ≤ 3.6 V		1.84		V
V _{CORE1(LPM)}	Core voltage, low-current mode, PMMCOREV = 1	2.0 V ≤ DV _{CC} ≤ 3.6 V		1.64		V
V _{CORE0(LPM)}	Core voltage, low-current mode, PMMCOREV = 0	1.8 V ≤ DV _{CC} ≤ 3.6 V		1.44		V

PMM, SVS High Side

over recommended ranges of supply voltage and operating free-air temperature (unless otherwise noted)

PARAMETER	TEST CONDITIONS	MIN TYP MAX			UNIT
$I_{(SVSH)}$ SVS current consumption	SVSHE = 0, DV _{CC} = 3.6 V		0		nA
	SVSHE = 1, DV _{CC} = 3.6 V, SVSHFP = 0		200		nA
	SVSHE = 1, DV _{CC} = 3.6 V, SVSHFP = 1		1.5		μA
$V_{(SVSH_IT-)}$ SVS _H on voltage level ⁽¹⁾	SVSHE = 1, SVSHRVL = 0	1.57	1.68	1.78	V
	SVSHE = 1, SVSHRVL = 1	1.79	1.88	1.98	
	SVSHE = 1, SVSHRVL = 2	1.98	2.08	2.21	
	SVSHE = 1, SVSHRVL = 3	2.10	2.18	2.31	
$V_{(SVSH_IT+)}$ SVS _H off voltage level ⁽¹⁾	SVSHE = 1, SVSMHRRL = 0	1.62	1.74	1.85	V
	SVSHE = 1, SVSMHRRL = 1	1.88	1.94	2.07	
	SVSHE = 1, SVSMHRRL = 2	2.07	2.14	2.28	
	SVSHE = 1, SVSMHRRL = 3	2.20	2.30	2.42	
	SVSHE = 1, SVSMHRRL = 4	2.32	2.40	2.55	
	SVSHE = 1, SVSMHRRL = 5	2.52	2.70	2.88	
	SVSHE = 1, SVSMHRRL = 6	2.90	3.10	3.23	
	SVSHE = 1, SVSMHRRL = 7	2.90	3.10	3.23	
$t_{pd(SVSH)}$ SVS _H propagation delay	SVSHE = 1, dV _{DVCC} /dt = 10 mV/μs, SVSHFP = 1		2.5		μs
	SVSHE = 1, dV _{DVCC} /dt = 1 mV/μs, SVSHFP = 0		20		
$t_{(SVSH)}$ SVS _H on or off delay time	SVSHE = 0 → 1, dV _{DVCC} /dt = 10 mV/μs, SVSHFP = 1		12.5		μs
	SVSHE = 0 → 1, dV _{DVCC} /dt = 1 mV/μs, SVSHFP = 0		100		
dV _{DVCC} /dt DV _{CC} rise time		0		1000	V/s

(1) The SVS_H settings available depend on the V_{CORE} (PMMCOREV_x) setting. See the *Power Management Module and Supply Voltage Supervisor* chapter in the *MSP430x5xx and MSP430x6xx Family User's Guide (SLAU208)* on recommended settings and use.

PMM, SVM High Side

over recommended ranges of supply voltage and operating free-air temperature (unless otherwise noted)

PARAMETER		TEST CONDITIONS	MIN	TYP	MAX	UNIT
$I_{(SVMH)}$	SVM _H current consumption	SVMHE = 0, DV _{CC} = 3.6 V		0		nA
		SVMHE = 1, DV _{CC} = 3.6 V, SVMHFP = 0		200		nA
		SVMHE = 1, DV _{CC} = 3.6 V, SVMHFP = 1		1.5		μA
$V_{(SVMH)}$	SVM _H on or off voltage level ⁽¹⁾	SVMHE = 1, SVSMHRRL = 0	1.62	1.74	1.85	V
		SVMHE = 1, SVSMHRRL = 1	1.88	1.94	2.07	
		SVMHE = 1, SVSMHRRL = 2	2.07	2.14	2.28	
		SVMHE = 1, SVSMHRRL = 3	2.20	2.30	2.42	
		SVMHE = 1, SVSMHRRL = 4	2.32	2.40	2.55	
		SVMHE = 1, SVSMHRRL = 5	2.52	2.70	2.88	
		SVMHE = 1, SVSMHRRL = 6	2.90	3.10	3.23	
		SVMHE = 1, SVSMHRRL = 7	2.90	3.10	3.23	
$t_{pd(SVMH)}$	SVM _H propagation delay	SVMHE = 1, dV _{DVCC} /dt = 10 mV/μs, SVMHFP = 1		2.5		μs
		SVMHE = 1, dV _{DVCC} /dt = 1 mV/μs, SVMHFP = 0		20		
$t_{(SVMH)}$	SVM _H on or off delay time	SVMHE = 0 → 1, dV _{DVCC} /dt = 10 mV/μs, SVMHFP = 1		12.5		μs
		SVMHE = 0 → 1, dV _{DVCC} /dt = 1 mV/μs, SVMHFP = 0		100		

(1) The SVM_H settings available depend on the V_{CORE} (PMMCOREV_x) setting. See the *Power Management Module and Supply Voltage Supervisor* chapter in the *MSP430x5xx and MSP430x6xx Family User's Guide (SLAU208)* on recommended settings and use.

PMM, SVS Low Side

over recommended ranges of supply voltage and operating free-air temperature (unless otherwise noted)

PARAMETER		TEST CONDITIONS	MIN	TYP	MAX	UNIT
$I_{(SVSL)}$	SVS _L current consumption	SVSLE = 0, PMMCOREV = 2		0		nA
		SVSLE = 1, PMMCOREV = 2, SVSLFP = 0		200		nA
		SVSLE = 1, PMMCOREV = 2, SVSLFP = 1		1.5		μA
$t_{pd(SVSL)}$	SVS _L propagation delay	SVSLE = 1, dV _{CORE} /dt = 10 mV/μs, SVSLFP = 1		2.5		μs
		SVSLE = 1, dV _{CORE} /dt = 1 mV/μs, SVSLFP = 0		20		
$t_{(SVSL)}$	SVS _L on or off delay time	SVSLE = 0 → 1, dV _{CORE} /dt = 10 mV/μs, SVSLFP = 1		12.5		μs
		SVSLE = 0 → 1, dV _{CORE} /dt = 1 mV/μs, SVSLFP = 0		100		

PMM, SVM Low Side

over recommended ranges of supply voltage and operating free-air temperature (unless otherwise noted)

PARAMETER		TEST CONDITIONS	MIN	TYP	MAX	UNIT
$I_{(SVML)}$	SVM _L current consumption	SVMLE = 0, PMMCOREV = 2		0		nA
		SVMLE = 1, PMMCOREV = 2, SVMLFP = 0		200		nA
		SVMLE = 1, PMMCOREV = 2, SVMLFP = 1		1.5		μA
$t_{pd(SVML)}$	SVM _L propagation delay	SVMLE = 1, $dV_{CORE}/dt = 10 \text{ mV}/\mu\text{s}$, SVMLFP = 1		2.5		μs
		SVMLE = 1, $dV_{CORE}/dt = 1 \text{ mV}/\mu\text{s}$, SVMLFP = 0		20		
$t_{(SVML)}$	SVM _L on or off delay time	SVMLE = 0 → 1, $dV_{CORE}/dt = 10 \text{ mV}/\mu\text{s}$, SVMLFP = 1		12.5		μs
		SVMLE = 0 → 1, $dV_{CORE}/dt = 1 \text{ mV}/\mu\text{s}$, SVMLFP = 0		100		

Wake-Up From Low-Power Modes and Reset

over recommended ranges of supply voltage and operating free-air temperature (unless otherwise noted)

PARAMETER		TEST CONDITIONS	MIN	TYP	MAX	UNIT	
$t_{WAKE-UP-FAST}$	Wake-up time from LPM2, LPM3, or LPM4 to active mode ⁽¹⁾	PMMCOREV = SVSMLRRL = n (where n = 0, 1, 2, or 3), SVSLFP = 1	$f_{MCLK} \geq 4.0 \text{ MHz}$		3.5	7.5	μs
				$1.0 \text{ MHz} < f_{MCLK} < 4.0 \text{ MHz}$		4.5	
$t_{WAKE-UP-SLOW}$	Wake-up time from LPM2, LPM3 or LPM4 to active mode ⁽²⁾	PMMCOREV = SVSMLRRL = n (where n = 0, 1, 2, or 3), SVSLFP = 0		150	175	μs	
$t_{WAKE-UP-LPM5}$	Wake-up time from LPM4.5 to active mode ⁽³⁾			2	3	ms	
$t_{WAKE-UP-RESET}$	Wake-up time from \overline{RST} or BOR event to active mode ⁽³⁾			2	3	ms	

- (1) This value represents the time from the wakeup event to the first active edge of MCLK. The wakeup time depends on the performance mode of the low side supervisor (SVS_L) and low side monitor (SVM_L). Fastest wakeup times are possible with SVS_L and SVM_L in full performance mode or disabled when operating in AM, LPM0, and LPM1. Various options are available for SVS_L and SVM_L while operating in LPM2, LPM3, and LPM4. See the *Power Management Module and Supply Voltage Supervisor* chapter in the *MSP430x5xx and MSP430x6xx Family User's Guide (SLAU208)*.
- (2) This value represents the time from the wakeup event to the first active edge of MCLK. The wakeup time depends on the performance mode of the low side supervisor (SVS_L) and low side monitor (SVM_L). In this case, the SVS_L and SVM_L are in normal mode (low current) mode when operating in AM, LPM0, and LPM1. Various options are available for SVS_L and SVM_L while operating in LPM2, LPM3, and LPM4. See the *Power Management Module and Supply Voltage Supervisor* chapter in the *MSP430x5xx and MSP430x6xx Family User's Guide (SLAU208)*.
- (3) This value represents the time from the wakeup event to the reset vector execution.

Timer_A

over recommended ranges of supply voltage and operating free-air temperature (unless otherwise noted)

PARAMETER		TEST CONDITIONS	V _{CC}	V _{IO}	MIN	MAX	UNIT
f _{TA}	Timer_A input clock frequency	Internal: SMCLK, ACLK External: TACLK Duty cycle = 50% ± 10%	1.8 V	1.62 V to 1.8 V		25	MHz
			3.0 V	1.62 V to 1.98 V		25	
t _{TA,cap}	Timer_A capture timing ⁽¹⁾	All capture inputs, Minimum pulse duration required for capture	1.8 V	1.62 V to 1.8 V	20		ns
			3.0 V	1.62 V to 1.98 V	20		

(1) The external signal sets the interrupt flag every time the minimum parameters are met. It may be set even with trigger signals shorter than t_{TA,cap}.

Timer_B

over recommended ranges of supply voltage and operating free-air temperature (unless otherwise noted)

PARAMETER		TEST CONDITIONS	V _{CC}	V _{IO}	MIN	MAX	UNIT
f _{TB}	Timer_B input clock frequency	Internal: SMCLK, ACLK External: TBCLK Duty cycle = 50% ± 10%	1.8 V	1.62 V to 1.8 V		25	MHz
			3.0 V	1.62 V to 1.98 V		25	
t _{TB,cap}	Timer_B capture timing ⁽¹⁾	All capture inputs, Minimum pulse duration required for capture	1.8 V	1.62 V to 1.8 V	20		ns
			3.0 V	1.62 V to 1.98 V	20		

(1) The external signal sets the interrupt flag every time the minimum parameters are met. It may be set even with trigger signals shorter than t_{TB,cap}.

USCI (UART Mode), Recommended Operating Conditions

PARAMETER		CONDITIONS	MIN	MAX	UNIT
f _{USCI}	USCI input clock frequency	Internal: SMCLK, ACLK External: UCLK Duty cycle = 50% ± 10%		f _{SYSTEM}	MHZ
f _{BITCLK}	BITCLK clock frequency (equals baud rate in MBaud)			1	MHZ

USCI (UART Mode)

over recommended ranges of supply voltage and operating free-air temperature (unless otherwise noted)

PARAMETER		V _{CC}	V _{IO}	MIN	MAX	UNIT
t _r	UART receive deglitch time ⁽¹⁾	1.8 V	1.62 V to 1.80 V	50	600	ns
		3.0 V	1.62 V to 1.98 V	50	600	

- (1) Pulses on the UART receive input (UCxRX) shorter than the UART receive deglitch time are suppressed. To make sure that pulses are correctly recognized, their duration should exceed the maximum specification of the deglitch time.

USCI (SPI Master Mode), Recommended Operating Conditions

PARAMETER		CONDITIONS	MIN	MAX	UNIT
f _{USCI}	USCI input clock frequency	Internal: SMCLK or ACLK, Duty cycle = 50% ± 10%		f _{SYSTEM}	MHZ

USCI (SPI Master Mode)

over recommended ranges of supply voltage and operating free-air temperature (unless otherwise noted)

(see Note ⁽¹⁾, Figure 14 and Figure 15)

PARAMETER		TEST CONDITIONS	V _{CC}	V _{IO}	MIN	MAX	UNIT
f _{USCI}	USCI input clock frequency	SMCLK or ACLK, Duty cycle = 50% ± 10%				f _{SYSTEM}	MHZ
t _{SU,MI}	SOMI input data setup time	PMMCOREV = 0	1.8 V	1.62 V to 1.80 V	55		ns
			3.0 V	1.62 V to 1.98 V	55		
		PMMCOREV = 3	2.4 V	1.62 V to 1.98 V	35		ns
			3.0 V	1.62 V to 1.98 V	35		
t _{HD,MI}	SOMI input data hold time	PMMCOREV = 0	1.8 V	1.62 V to 1.80 V	0		ns
			3.0 V	1.62 V to 1.98 V	0		
		PMMCOREV = 3	2.4 V	1.62 V to 1.98 V	0		ns
			3.0 V	1.62 V to 1.98 V	0		
t _{VALID,MO}	SIMO output data valid time ⁽²⁾	UCLK edge to SIMO valid, C _L = 20 pF, PMMCOREV = 0	1.8 V	1.62 V to 1.80 V		20	ns
			3.0 V	1.62 V to 1.98 V		20	
		UCLK edge to SIMO valid, C _L = 20 pF, PMMCOREV = 3	2.4 V	1.62 V to 1.98 V		16	ns
			3.0 V	1.62 V to 1.98 V		16	
t _{HD,MO}	SIMO output data hold time ⁽³⁾	C _L = 20 pF, PMMCOREV = 0	1.8 V	1.62 V to 1.80 V	-10		ns
			3.0 V	1.62 V to 1.98 V	-10		
		C _L = 20 pF, PMMCOREV = 3	2.4 V	1.62 V to 1.98 V	-10		ns
			3.0 V	1.62 V to 1.98 V	-10		

- (1) f_{UCxCLK} = 1/2t_{LO/HI} with t_{LO/HI} ≥ max(t_{VALID,MO(USCI)} + t_{SU,SI(Slave)}, t_{SU,MI(USCI)} + t_{VALID,SO(Slave)}).
For the slave's parameters t_{SU,SI(Slave)} and t_{VALID,SO(Slave)} see the SPI parameters of the attached slave.
- (2) Specifies the time to drive the next valid data to the SIMO output after the output changing UCLK clock edge. See the timing diagrams in Figure 14 and Figure 15.
- (3) Specifies how long data on the SIMO output is valid after the output changing UCLK clock edge. Negative values indicate that the data on the SIMO output can become invalid before the output changing clock edge observed on UCLK. See the timing diagrams in Figure 14 and Figure 15.

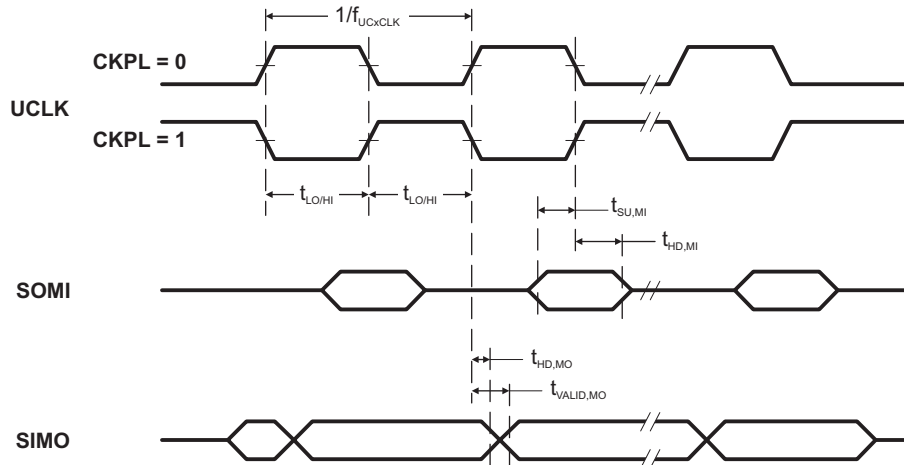

Figure 14. SPI Master Mode, CKPH = 0

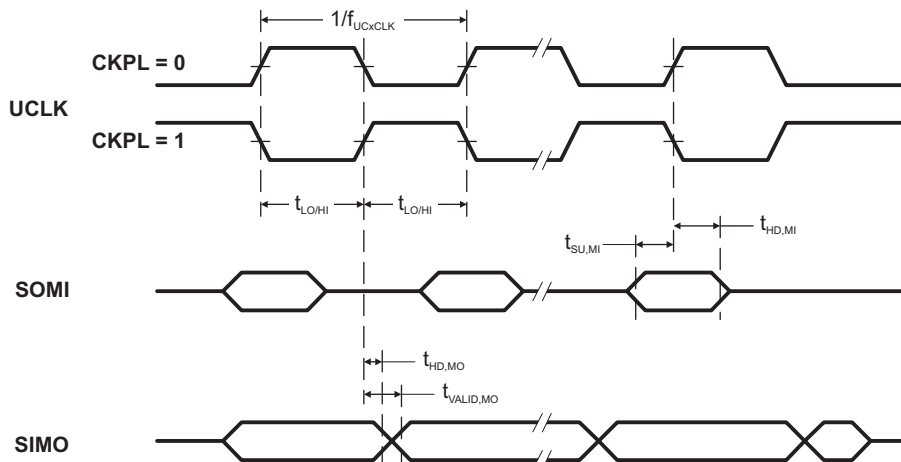

Figure 15. SPI Master Mode, CKPH = 1

USCI (SPI Slave Mode)

over recommended ranges of supply voltage and operating free-air temperature (unless otherwise noted)
(see Note ⁽¹⁾, [Figure 16](#) and [Figure 17](#))

PARAMETER		TEST CONDITIONS	V _{CC}	V _{IO}	MIN	MAX	UNIT
t _{STE,LEAD}	STE lead time, STE low to clock	PMMCOREV = 0	1.8 V	1.62 V to 1.80 V	12		ns
			3.0 V	1.62 V to 1.98 V	12		
		PMMCOREV = 3	2.4 V	1.62 V to 1.98 V	10		ns
			3.0 V	1.62 V to 1.98 V	10		
t _{STE,LAG}	STE lag time, Last clock to STE high	PMMCOREV = 0	1.8 V	1.62 V to 1.80 V	6		ns
			3.0 V	1.62 V to 1.98 V	6		
		PMMCOREV = 3	2.4 V	1.62 V to 1.98 V	6		ns
			3.0 V	1.62 V to 1.98 V	6		
t _{STE,ACC}	STE access time, STE low to SOMI data out	PMMCOREV = 0	1.8 V	1.62 V to 1.80 V		65	ns
			3.0 V	1.62 V to 1.98 V		65	
		PMMCOREV = 3	2.4 V	1.62 V to 1.98 V		45	ns
			3.0 V	1.62 V to 1.98 V		45	
t _{STE,DIS}	STE disable time, STE high to SOMI high impedance	PMMCOREV = 0	1.8 V	1.62 V to 1.80 V		35	ns
			3.0 V	1.62 V to 1.98 V		35	
		PMMCOREV = 3	2.4 V	1.62 V to 1.98 V		25	ns
			3.0 V	1.62 V to 1.98 V		25	
t _{SU,SI}	SIMO input data setup time	PMMCOREV = 0	1.8 V	1.62 V to 1.80 V	5		ns
			3.0 V	1.62 V to 1.98 V	5		
		PMMCOREV = 3	2.4 V	1.62 V to 1.98 V	5		ns
			3.0 V	1.62 V to 1.98 V	5		
t _{HD,SI}	SIMO input data hold time	PMMCOREV = 0	1.8 V	1.62 V to 1.80 V	5		ns
			3.0 V	1.62 V to 1.98 V	5		
		PMMCOREV = 3	2.4 V	1.62 V to 1.98 V	5		ns
			3.0 V	1.62 V to 1.98 V	5		
t _{VALID,SO}	SOMI output data valid time ⁽²⁾	UCLK edge to SOMI valid, C _L = 20 pF, PMMCOREV = 0	1.8 V	1.62 V to 1.80 V		75	ns
			3.0 V	1.62 V to 1.98 V		75	
		UCLK edge to SOMI valid, C _L = 20 pF, PMMCOREV = 3	2.4 V	1.62 V to 1.98 V		50	ns
			3.0 V	1.62 V to 1.98 V		50	
t _{HD,SO}	SOMI output data hold time ⁽³⁾	C _L = 20 pF, PMMCOREV = 0	1.8 V	1.62 V to 1.80 V	10		ns
			3.0 V	1.62 V to 1.98 V	10		
		C _L = 20 pF, PMMCOREV = 3	2.4 V	1.62 V to 1.98 V	10		ns
			3.0 V	1.62 V to 1.98 V	10		

(1) $f_{UCxCLK} = 1/2t_{LO/HI}$ with $t_{LO/HI} \geq \max(t_{VALID,MO(Master)} + t_{SU,SI(USCI)}, t_{SU,MI(Master)} + t_{VALID,SO(USCI)})$.

For the master's parameters $t_{SU,MI(Master)}$ and $t_{VALID,MO(Master)}$ see the SPI parameters of the attached slave.

(2) Specifies the time to drive the next valid data to the SOMI output after the output changing UCLK clock edge. See the timing diagrams in [Figure 16](#) and [Figure 17](#).

(3) Specifies how long data on the SOMI output is valid after the output changing UCLK clock edge. See the timing diagrams in [Figure 16](#) and [Figure 17](#).

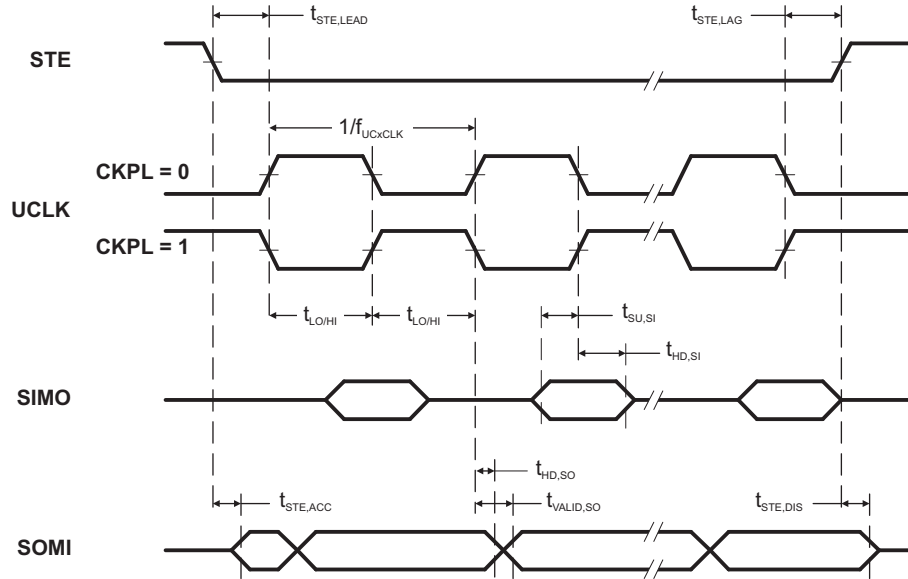

Figure 16. SPI Slave Mode, CKPH = 0

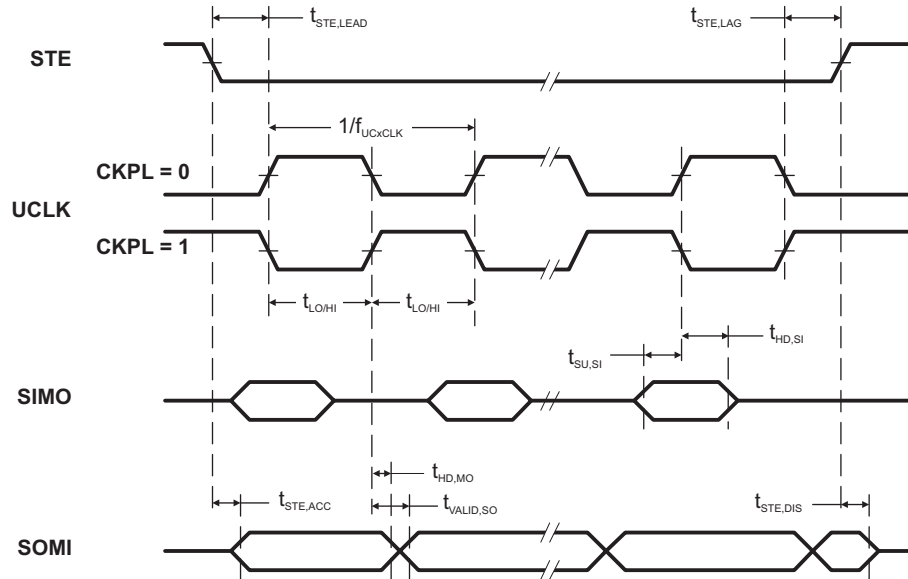

Figure 17. SPI Slave Mode, CKPH = 1

USCI (I2C Mode)

over recommended ranges of supply voltage and operating free-air temperature (unless otherwise noted) (see [Figure 18](#))

PARAMETER	TEST CONDITIONS	V _{CC}	V _{IO} ⁽¹⁾	MIN	MAX	UNIT
f _{USCI}	USCI input clock frequency				f _{SYSTEM}	MHz
f _{SCL}	SCL clock frequency	2.2 V, 3 V	1.62 V to 1.98 V	0	400	kHz
t _{HD,STA}	Hold time (repeated) START	2.2 V, 3 V	1.62 V to 1.98 V	f _{SCL} ≤ 100 kHz	4.0	μs
				f _{SCL} > 100 kHz	0.6	
t _{SU,STA}	Setup time for a repeated START	2.2 V, 3 V	1.62 V to 1.98 V	f _{SCL} ≤ 100 kHz	4.7	μs
				f _{SCL} > 100 kHz	0.6	
t _{HD,DAT}	Data hold time	2.2 V, 3 V	1.62 V to 1.98 V	0		ns
t _{SU,DAT}	Data setup time	2.2 V, 3 V	1.62 V to 1.98 V	250		ns
t _{SU,STO}	Setup time for STOP	2.2 V, 3 V	1.62 V to 1.98 V	f _{SCL} ≤ 100 kHz	4.0	μs
				f _{SCL} > 100 kHz	0.6	
t _{SP}	Pulse duration of spikes suppressed by input filter	2.2 V, 3 V	1.62 V to 1.98 V	50	600	ns

(1) In all test conditions, V_{IO} ≤ V_{CC}

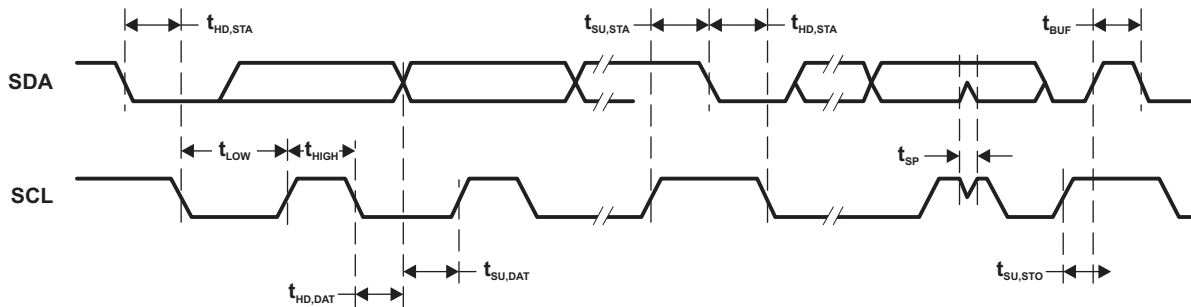

Figure 18. I2C Mode Timing

10-Bit ADC, Power Supply and Input Range Conditions

over recommended ranges of supply voltage and operating free-air temperature (unless otherwise noted)⁽¹⁾

PARAMETER		TEST CONDITIONS	V _{CC}	MIN	TYP	MAX	UNIT
AV _{CC}	Analog supply voltage	AV _{CC} and DV _{CC} are connected together, AV _{SS} and DV _{SS} are connected together, V _(AVSS) = V _(DVSS) = 0 V		1.8		3.6	V
V _(Ax)	Analog input voltage range ⁽²⁾	All ADC10_A pins: P1.0 to P1.5 and P3.6 and P3.7 terminals		0		AV _{CC}	V
I _{ADC10_A}	Operating supply current into AV _{CC} terminal, REF module and reference buffer off	f _{ADC10CLK} = 5.0 MHz, ADC10ON = 1, REFON = 0, SHT0 = 0, SHT1 = 0, ADC10DIV = 0, ADC10SREF = 00	2.2 V		60	100	μA
			3 V		75	110	
	Operating supply current into AV _{CC} terminal, REF module on, reference buffer on	f _{ADC10CLK} = 5.0 MHz, ADC10ON = 1, REFON = 1, SHT0 = 0, SHT1 = 0, ADC10DIV = 0, ADC10SREF = 01	3 V		113	150	μA
		f _{ADC10CLK} = 5.0 MHz, ADC10ON = 1, REFON = 0, SHT0 = 0, SHT1 = 0, ADC10DIV = 0, ADC10SREF = 10, VREF = 2.5 V	3 V		105	140	μA
Operating supply current into AV _{CC} terminal, REF module off, reference buffer off	f _{ADC10CLK} = 5.0 MHz, ADC10ON = 1, REFON = 0, SHT0 = 0, SHT1 = 0, ADC10DIV = 0, ADC10SREF = 11, VREF = 2.5 V	3 V		70	110	μA	
C _I	Input capacitance	Only one terminal Ax can be selected at one time from the pad to the ADC10_A capacitor array including wiring and pad	2.2 V		3.5		pF
R _I	Input MUX ON resistance	AV _{CC} > 2 V, 0 V ≤ V _{Ax} ≤ AV _{CC}				36	kΩ
		1.8 V < AV _{CC} < 2 V, 0 V ≤ V _{Ax} ≤ AV _{CC}				96	

(1) The leakage current is defined in the leakage current table with P6.x/Ax parameter.

(2) The analog input voltage range must be within the selected reference voltage range V_{R+} to V_{R-} for valid conversion results. The external reference voltage requires decoupling capacitors. See ⁽¹⁾.

10-Bit ADC, Timing Parameters

over recommended ranges of supply voltage and operating free-air temperature (unless otherwise noted)

PARAMETER		TEST CONDITIONS	V _{CC}	MIN	TYP	MAX	UNIT
f _{ADC10CLK}		For specified performance of ADC10_A linearity parameters	2.2 V, 3 V	0.45	5	5.5	MHz
f _{ADC10OSC}	Internal ADC10_A oscillator ⁽¹⁾	ADC10DIV = 0, f _{ADC10CLK} = f _{ADC10OSC}	2.2 V, 3 V	4.2	4.8	5.4	MHz
t _{CONVERT}	Conversion time	REFON = 0, Internal oscillator, 12 ADC10CLK cycles, 10-bit mode f _{ADC10OSC} = 4 MHz to 5 MHz	2.2 V, 3 V	2.4		3.0	μs
		External f _{ADC10CLK} from ACLK, MCLK or SMCLK, ADC10SSEL ≠ 0					
⁽²⁾ t _{ADC10ON}	Turn on settling time of the ADC	See ⁽³⁾				100	ns
t _{Sample}	Sampling time	R _S = 1000 Ω, R _I = 96 k Ω, C _I = 3.5 pF ⁽⁴⁾	1.8 V	3			μs
			3.0 V	1			μs

(1) The ADC10OSC is sourced directly from MODOSC inside the UCS.

(2) 12 × ADC10DIV × 1/f_{ADC10CLK}

(3) The condition is that the error in a conversion started after t_{ADC10ON} is less than ±0.5 LSB. The reference and input signal are already settled.

(4) Approximately eight Tau (τ) are needed to get an error of less than ±0.5 LSB

10-Bit ADC, Linearity Parameters

over recommended ranges of supply voltage and operating free-air temperature (unless otherwise noted)

PARAMETER		TEST CONDITIONS	V _{CC}	MIN	TYP	MAX	UNIT
E _I	Integral linearity error	$1.4\text{ V} \leq (V_{eREF+} - V_{REF-}/N_{eREF-})_{min} \leq 1.6\text{ V}$	2.2 V, 3 V			±1.0	LSB
		$1.6\text{ V} < (V_{eREF+} - V_{REF-}/N_{eREF-})_{min} \leq V_{AVCC}$				±1.0	
E _D	Differential linearity error	$(V_{eREF+} - V_{REF-}/N_{eREF-})_{min} \leq (V_{eREF+} - V_{REF-}/N_{eREF-})$, C _{VREF+} = 20 pF	2.2 V, 3 V			±1.0	LSB
E _O	Offset error	$(V_{eREF+} - V_{REF-}/N_{eREF-})_{min} \leq (V_{eREF+} - V_{REF-}/N_{eREF-})$, Internal impedance of source R _S < 100 Ω, C _{VREF+} = 20 pF	2.2 V, 3 V			±1.0	LSB
E _G	Gain error	$(V_{eREF+} - V_{REF-}/N_{eREF-})_{min} \leq (V_{eREF+} - V_{REF-}/N_{eREF-})$, C _{VREF+} = 20 pF	2.2 V, 3 V			±1.0	LSB
E _T	Total unadjusted error	$(V_{eREF+} - V_{REF-}/N_{eREF-})_{min} \leq (V_{eREF+} - V_{REF-}/N_{eREF-})$, C _{VREF+} = 20 pF	2.2 V, 3 V		±1.0	±2.0	LSB

REF, External Reference

over recommended ranges of supply voltage and operating free-air temperature (unless otherwise noted)⁽¹⁾

PARAMETER		TEST CONDITIONS	V _{CC}	MIN	MAX	UNIT
V _{eREF+}	Positive external reference voltage input	$V_{eREF+} > V_{REF-}/N_{eREF-}$ ⁽²⁾		1.4	V _{CC}	V
V _{eREF-}	Negative external reference voltage input	$V_{eREF+} > V_{REF-}/N_{eREF-}$ ⁽³⁾		0	1.2	V
(V _{eREF+} - V _{eREF-})	Differential external reference voltage input	$V_{eREF+} > V_{REF-}/N_{eREF-}$ ⁽⁴⁾		1.4	V _{CC}	V
I _{VeREF+} , I _{VeREF-}	Static input current	$1.4\text{ V} \leq V_{eREF+} \leq V_{AVCC}$, V _{eREF-} = 0 V, f _{ADC10CLK} = 5 MHz, ADC10SHTX = 0x0001, Conversion rate 200 ksp/s	2.2 V, 3 V	-26	26	μA
		$1.4\text{ V} \leq V_{eREF+} \leq V_{AVCC}$, V _{eREF-} = 0 V, f _{ADC10CLK} = 5 MHz, ADC10SHTX = 0x1000, Conversion rate 20 ksp/s	2.2 V, 3 V	-1	1	μA
C _{VREF+} , C _{VREF-}	Capacitance at VeREF+ or VeREF- terminal	See ⁽⁵⁾		10		μF

- (1) The external reference is used during ADC conversion to charge and discharge the capacitance array. The input capacitance, C_i, is also the dynamic load for an external reference during conversion. The dynamic impedance of the reference supply should follow the recommendations on analog-source impedance to allow the charge to settle for 10-bit accuracy.
- (2) The accuracy limits the minimum positive external reference voltage. Lower reference voltage levels may be applied with reduced accuracy requirements.
- (3) The accuracy limits the maximum negative external reference voltage. Higher reference voltage levels may be applied with reduced accuracy requirements.
- (4) The accuracy limits minimum external differential reference voltage. Lower differential reference voltage levels may be applied with reduced accuracy requirements.
- (5) Two decoupling capacitors, 10 μF and 100 nF, should be connected to VREF to decouple the dynamic current required for an external reference source if it is used for the ADC10_A. See also the *MSP430x5xx and MSP430x6xx Family User's Guide (SLAU208)*.

REF, Built-In Reference

 over recommended ranges of supply voltage and operating free-air temperature (unless otherwise noted)⁽¹⁾

PARAMETER	TEST CONDITIONS	V _{CC}	MIN	TYP	MAX	UNIT
V _{REF+}	REFVSEL = {2} for 2.5 V REFON = 1	3 V	2.445	2.486	2.527	V
	REFVSEL = {1} for 2.0 V REFON = 1	3 V	1.94	1.97	2.01	
	REFVSEL = {0} for 1.5 V REFON = 1	2.2 V, 3 V	1.461	1.485	1.511	
AV _{CC(min)}	REFVSEL = {0} for 1.5 V		2.2			V
	REFVSEL = {1} for 2.0 V		2.2			
	REFVSEL = {2} for 2.5 V		2.7			
I _{REF+}	f _{ADC10CLK} = 5.0 MHz REFON = 1, REFBURST = 0, REFVSEL = {2} for 2.5 V	3 V		18	24	μA
	f _{ADC10CLK} = 5.0 MHz REFON = 1, REFBURST = 0, REFVSEL = {1} for 2.0 V	3 V		15.5	21	μA
	f _{ADC10CLK} = 5.0 MHz REFON = 1, REFBURST = 0, REFVSEL = {0} for 1.5 V	3 V		13.5	21	μA
TC _{REF+}	I _{VREF+} = 0 A REFVSEL = (0, 1, 2), REFON = 1			30	50	ppm/ °C
I _{SENSOR}	REFON = 0, INCH = 0Ah, ADC10ON = N/A, T _A = 30°C	2.2 V		20	22	μA
		3 V		20	22	
V _{SENSOR}	See ⁽⁵⁾	2.2 V		770		mV
		3 V		770		
V _{MID}	ADC10ON = 1, INCH = 0Bh, V _{MID} is approximately 0.5 × V _{AVCC}	2.2 V	1.06	1.1	1.14	V
		3 V	1.46	1.5	1.54	
t _{SENSOR(sample)}	ADC10ON = 1, INCH = 0Ah, Error of conversion result ≤ 1 LSB		30			μs
t _{VMID(sample)}	ADC10ON = 1, INCH = 0Bh, Error of conversion result ≤ 1 LSB		1			μs
PSRR _{DC}	AV _{CC} = AV _{CC(min)} - AV _{CC(max)} , T _A = 25°C, REFVSEL = (0, 1, 2), REFON = 1			120		μV/V
PSRR _{AC}	AV _{CC} = AV _{CC(min)} - AV _{CC(max)} , T _A = 25°C, f = 1 kHz, ΔV _{pp} = 100 mV, REFVSEL = (0, 1, 2), REFON = 1			6.4		mV/V
t _{SETTLE}	AV _{CC} = AV _{CC(min)} - AV _{CC(max)} , REFVSEL = (0, 1, 2), REFON = 0 → 1			75		μs

- (1) The leakage current is defined in the leakage current table with P6.x/Ax parameter.
- (2) The internal reference current is supplied via terminal AVCC. Consumption is independent of the ADC10ON control bit, unless a conversion is active. The REFON bit enables to settle the built-in reference before starting an A/D conversion.
- (3) Calculated using the box method: (MAX(-40 to 85°C) - MIN(-40 to 85°C)) / MIN(-40 to 85°C)/(85°C - (-40°C)).
- (4) The sensor current I_{SENSOR} is consumed if (ADC10ON = 1 and REFON = 1) or (ADC10ON = 1 and INCH = 0Ah and sample signal is high). When REFON = 1, I_{SENSOR} is already included in I_{REF+}.
- (5) The temperature sensor offset can be significant. A single-point calibration is recommended to minimize the offset error of the built-in temperature sensor.
- (6) The typical equivalent impedance of the sensor is 51 kΩ. The sample time required includes the sensor-on time t_{SENSOR(on)}.
- (7) The on-time t_{VMID(on)} is included in the sampling time t_{VMID(sample)}; no additional on time is needed.
- (8) The condition is that the error in a conversion started after t_{REFON} is less than ±0.5 LSB.

Comparator_B

over recommended ranges of supply voltage and operating free-air temperature (unless otherwise noted)

PARAMETER	TEST CONDITIONS	V _{CC}	MIN	TYP	MAX	UNIT	
V _{CC}	Supply voltage		1.8		3.6	V	
I _{AVCC_COMP}	Comparator operating supply current into AV _{CC} . Excludes reference resistor ladder.	CBPWRMD = 00, CBON = 1, CBRSx = 00	1.8 V		38	μA	
			2.2 V	31	38		
			3 V	32	39		
		2.2 V, 3 V	10	17			
	CBPWRMD = 10, CBON = 1, CBRSx = 00	2.2 V, 3 V		0.2	0.85		
V _{REF}	Reference voltage level	CBREFLx = 01, CBREFACC = 0	≥ 1.8V	1.400	1.43	1.472	V
		CBREFLx = 10, CBREFACC = 0	≥ 2.2V	1.864	1.90	1.960	
		CBREFLx = 11, CBREFACC = 0	≥ 3.0V	2.32	2.37	2.44	
I _{AVCC_REF}	Quiescent current of resistor ladder into AV _{CC} . Including REF module current.	CBREFACC = 0, CBREFLx = 01, CBRSx = 10, REFON = 0, CBON = 0	2.2 V, 3 V	33	40	μA	
		CBREFACC = 1, CBREFLx = 01, CBRSx = 10, REFON = 0, CBON = 0	2.2 V, 3 V	17	22	μA	
V _{IC}	Common mode input range		0		V _{CC} -1	V	
V _{OFFSET}	Input offset voltage	CBPWRMD = 00		-20	20	mV	
		CBPWRMD = 01, 10		-10	10	mV	
C _{IN}	Input capacitance			5		pF	
R _{SIN}	Series input resistance	ON - switch closed		3	4	kΩ	
		OFF - switch opened		50		MΩ	
t _{PD}	Propagation delay, response time	CBPWRMD = 00, CBF = 0			450	ns	
		CBPWRMD = 01, CBF = 0			600	ns	
		CBPWRMD = 10, CBF = 0			50	μs	
t _{PD,filter}	Propagation delay with filter active	CBPWRMD = 00, CBON = 1, CBF = 1, CBF _{DLY} = 00		0.35	0.6	1.5	μs
		CBPWRMD = 00, CBON = 1, CBF = 1, CBF _{DLY} = 01		0.6	1.0	1.8	μs
		CBPWRMD = 00, CBON = 1, CBF = 1, CBF _{DLY} = 10		1.0	1.8	3.4	μs
		CBPWRMD = 00, CBON = 1, CBF = 1, CBF _{DLY} = 11		1.8	3.4	6.5	μs
t _{EN_CMP}	Comparator enable time	CBON = 0 to CBON = 1, CBPWRMD = 00, 01		1	2	μs	
t _{EN_REF}	Resistor reference enable time	CBON = 0 to CBON = 1		1.0	1.5	μs	
TC _{REF}	Temperature coefficient reference				50	ppm/°C	
V _{CB_REF}	Reference voltage for a given tap	VIN = reference into resistor ladder, n = 0 to 31		VIN × (n+0.5) / 32	VIN × (n+1) / 32	VIN × (n+1.5) / 32	V

Flash Memory

over recommended ranges of supply voltage and operating free-air temperature (unless otherwise noted)

PARAMETER		TEST CONDITIONS	MIN	TYP	MAX	UNIT
$DV_{CC(PGM/ERASE)}$	Program and erase supply voltage		1.8		3.6	V
I_{PGM}	Average supply current from DVCC during program			3	5	mA
I_{ERASE}	Average supply current from DVCC during erase			6	11	mA
I_{MERASE}, I_{BANK}	Average supply current from DVCC during mass erase or bank erase			6	11	mA
t_{CPT}	Cumulative program time	See ⁽¹⁾			16	ms
	Program and erase endurance		10^4	10^5		cycles
$t_{Retention}$	Data retention duration	$T_J = 25^\circ\text{C}$	100			years
t_{Word}	Word or byte program time	See ⁽²⁾	64		85	μs
$t_{Block, 0}$	Block program time for first byte or word	See ⁽²⁾	49		65	μs
$t_{Block, 1-(N-1)}$	Block program time for each additional byte or word, except for last byte or word	See ⁽²⁾	37		49	μs
$t_{Block, N}$	Block program time for last byte or word	See ⁽²⁾	55		73	μs
t_{Erase}	Erase time for segment, mass erase, and bank erase when available	See ⁽²⁾	23		32	ms
$f_{MCLK, MGR}$	MCLK frequency in marginal read mode (FCTL4.MGR0 = 1 or FCTL4.MGR1 = 1)		0		1	MHz

- (1) The cumulative program time must not be exceeded when writing to a 128-byte flash block. This parameter applies to all programming methods: individual word or byte write mode and block write mode.
 (2) These values are hardwired into the flash controller's state machine.

JTAG and Spy-Bi-Wire Interface

over recommended ranges of supply voltage and operating free-air temperature (unless otherwise noted)

PARAMETER		V_{CC}	V_{IO}	MIN	TYP	MAX	UNIT
f_{SBW}	Spy-Bi-Wire input frequency	2.2 V, 3 V	1.62 V to 1.98 V	0		20	MHz
$t_{SBW, Low}$	Spy-Bi-Wire low clock pulse length	2.2 V, 3 V	1.62 V to 1.98 V	0.025		15	μs
$t_{SBW, En}$	Spy-Bi-Wire enable time (TEST high to acceptance of first clock edge)		1.62 V to 1.98 V			1	μs
$t_{SBW, Rst}$	Spy-Bi-Wire return to normal operation time	2.2 V, 3 V	1.62 V to 1.98 V	15		100	μs
f_{TCK}	TCK input frequency for 4-wire JTAG	2.2 V	1.62 V to 1.98 V	0		5	MHz
		3 V	1.62 V to 1.98 V	0		10	MHz
$R_{internal}$	Internal pulldown resistance on TEST	2.2 V, 3 V	1.62 V to 1.98 V	45	60	80	k Ω

DVIO BSL Entry

over recommended ranges of supply voltage and operating free-air temperature (unless otherwise noted)

PARAMETER		V _{CC}	V _{IO}	MIN	MAX	UNIT
t _{SU, BSL}	Setup time, BSL to $\overline{\text{RST/NMI}}$ ⁽¹⁾	2.2 V, 3 V	1.62 V to 1.98 V	100		ns
t _{HO, BSL}	Hold time, BSL to $\overline{\text{RST/NMI}}$ ⁽²⁾	2.2 V, 3 V	1.62 V to 1.98 V	350		μs

- (1) AVCC, DVCC, DVIO stable and within specification.
- (2) BSL must remain logically high long enough for the boot code to detect its level and enter the BSL sequence. After the minimum hold time is achieved, BSL is a don't care.

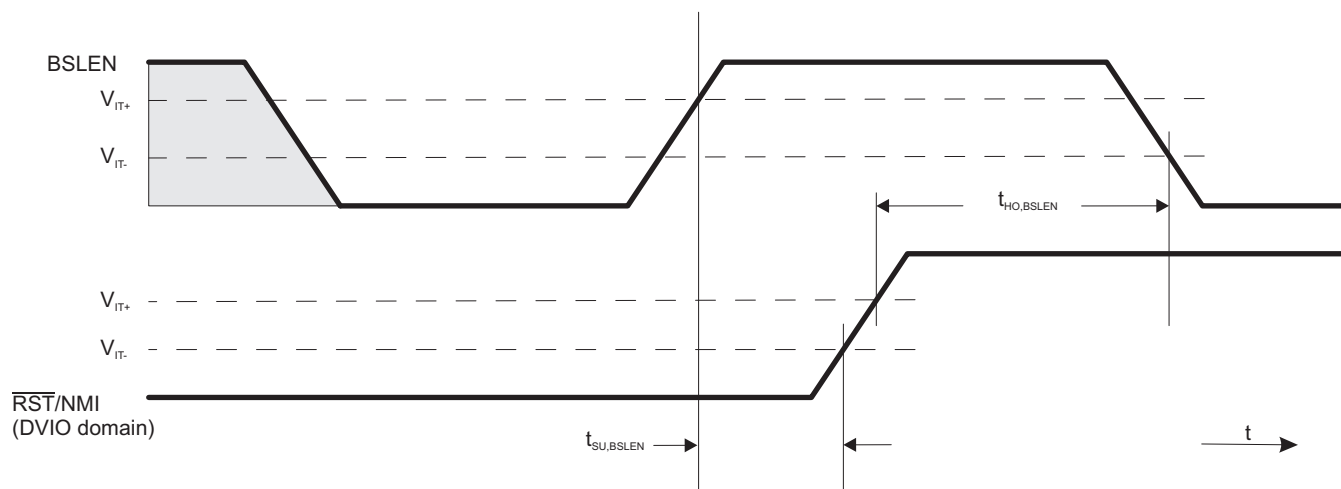
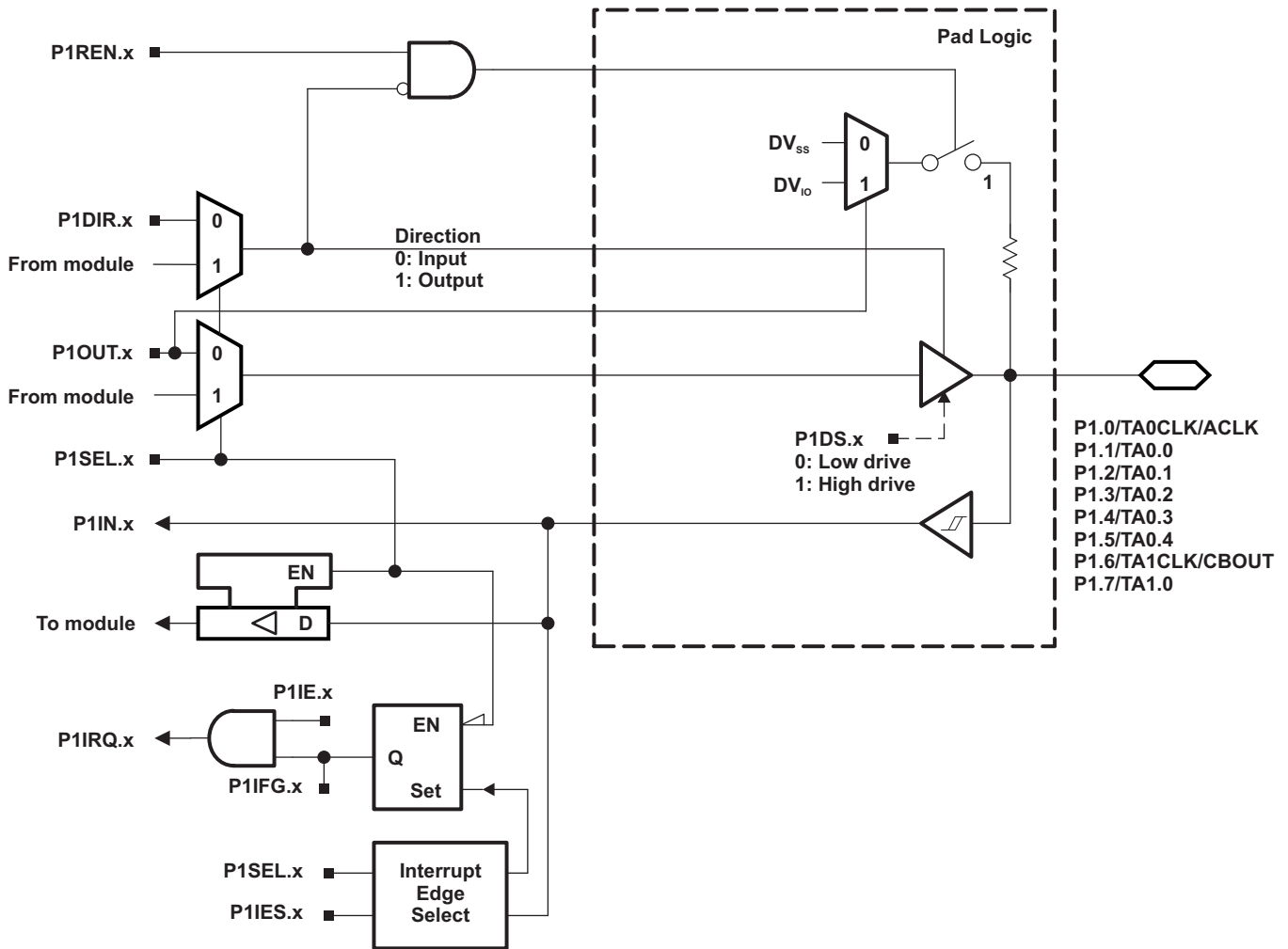

Figure 19. DVIO BSL Entry Timing

INPUT/OUTPUT SCHEMATICS

Port P1, P1.0 to P1.7, Input/Output With Schmitt Trigger



PRODUCT PREVIEW

Table 52. Port P1 (P1.0 to P1.7) Pin Functions

PIN NAME (P1.x)	x	FUNCTION	CONTROL BITS AND SIGNALS	
			P1DIR.x	P1SEL.x
P1.0/TA0CLK/ACLK	0	P1.0 (I/O)	I: 0; O: 1	0
		TA0CLK	0	1
		ACLK	1	1
P1.1/TA0.0	1	P1.1 (I/O)	I: 0; O: 1	0
		TA0.CCI0A	0	1
		TA0.0	1	1
P1.2/TA0.1	2	P1.2 (I/O)	I: 0; O: 1	0
		TA0.CCI1A	0	1
		TA0.1	1	1
P1.3/TA0.2	3	P1.3 (I/O)	I: 0; O: 1	0
		TA0.CCI2A	0	1
		TA0.2	1	1
P1.4/TA0.3	4	P1.4 (I/O)	I: 0; O: 1	0
		TA0.CCI3A	0	1
		TA0.3	1	1
P1.5/TA0.4	5	P1.5 (I/O)	I: 0; O: 1	0
		TA0.CCI4A	0	1
		TA0.4	1	1
P1.6/TA1CLK/CBOUT	6	P1.6 (I/O)	I: 0; O: 1	0
		TA1CLK	0	1
		CBOUT comparator B	1	1
P1.7/TA1.0	7	P1.7 (I/O)	I: 0; O: 1	0
		TA1.CCI0A	0	1
		TA1.0	1	1

PRODUCT PREVIEW

Port P2, P2.0 to P2.7, Input/Output With Schmitt Trigger

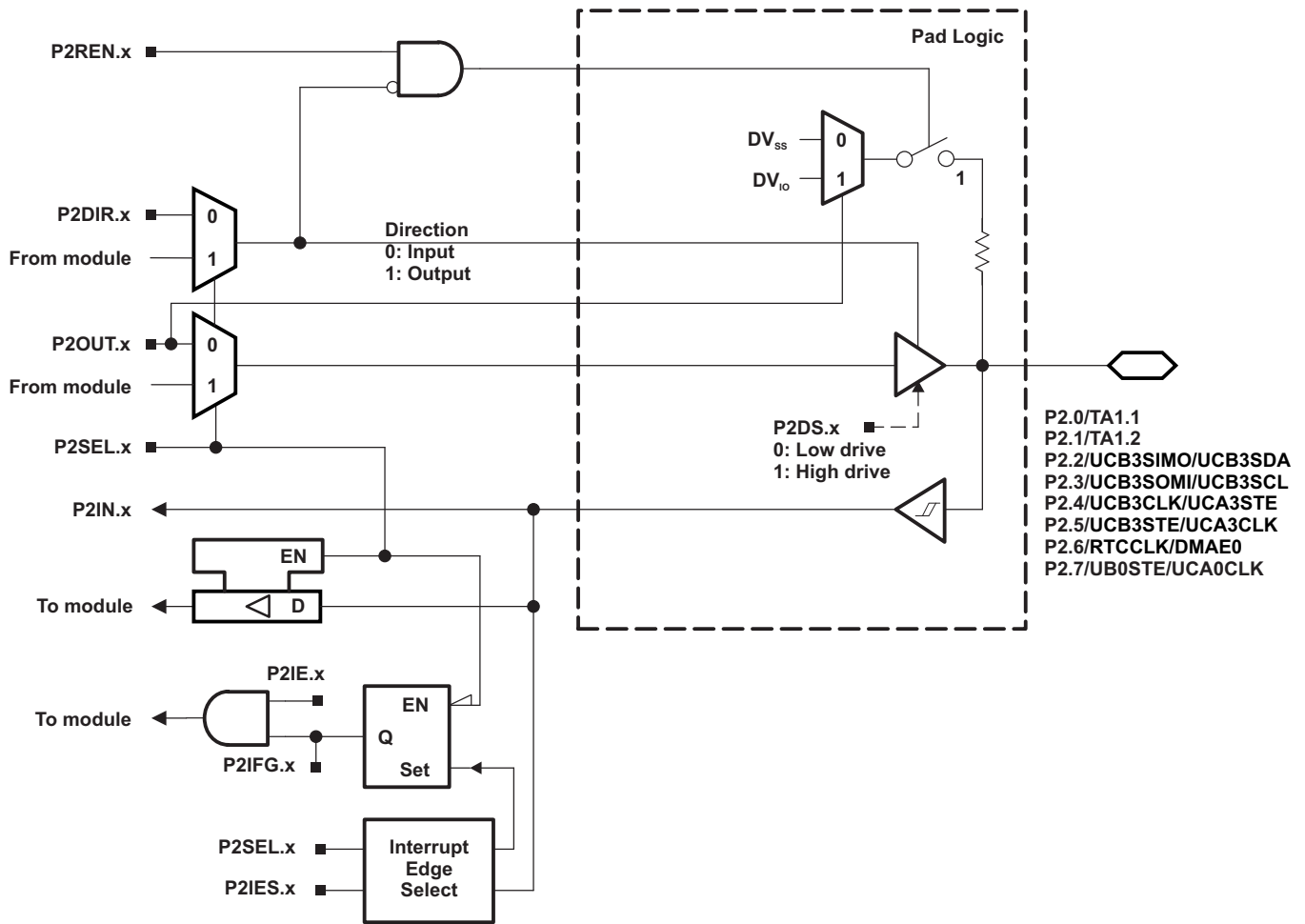

PRODUCT PREVIEW

Table 53. Port P2 (P2.0 to P2.7) Pin Functions

PIN NAME (P2.x)	x	FUNCTION	CONTROL BITS AND SIGNALS ⁽¹⁾	
			P2DIR.x	P2SEL.x
P2.0/TA1.1	0	P2.0 (I/O)	I: 0; O: 1	0
		TA1.CCI1A	0	1
		TA1.1	1	1
P2.1/TA1.2	1	P2.1 (I/O)	I: 0; O: 1	0
		TA1.CCI2A	0	1
		TA1.2	1	1
P2.2/UCB3SIMO/UCB3SDA	2	P2.2 (I/O)	I: 0; O: 1	0
		UCB3SIMO/UCB3SDA	X	1
P2.3/UCB3SOMI/UCB3SCL	3	P2.3 (I/O)	I: 0; O: 1	0
		UCB3SOMI/UCB3SCL	X	1
P2.4/UCB3CLK/UCA3STE	4	P2.4 (I/O)	I: 0; O: 1	0
		UCB3CLK/UCA3STE ^{(2) (3)}	X	1
P2.5/UCB3STE/UCA3CLK	5	P2.5 (I/O)	I: 0; O: 1	0
		UCB3STE/UCA3CLK ^{(2) (4)}	X	1
P2.6/RTCCLK/DMAE0	6	P2.6 (I/O)	I: 0; O: 1	0
		DMAE0	0	1
		RTCCLK	1	1
P2.7/UCB0STE/UCA0CLK	7	P2.7 (I/O)	I: 0; O: 1	0
		UCB0STE/UCA0CLK ^{(2) (5)}	X	1

- (1) X = Don't care
- (2) The pin direction is controlled by the USCI module.
- (3) UCB3CLK function takes precedence over UCA3STE function. If the pin is required as UCB3CLK input or output, USCI_A3 is forced to 3-wire SPI mode if 4-wire SPI mode is selected.
- (4) UCA3CLK function takes precedence over UCB3STE function. If the pin is required as UCA3CLK input or output, USCI_B3 is forced to 3-wire SPI mode if 4-wire SPI mode is selected.
- (5) UCA0CLK function takes precedence over UCB0STE function. If the pin is required as UCA0CLK input or output, USCI_B0 is forced to 3-wire SPI mode if 4-wire SPI mode is selected.

PRODUCT PREVIEW

Port P3, P3.0 to P3.4, Input/Output With Schmitt Trigger

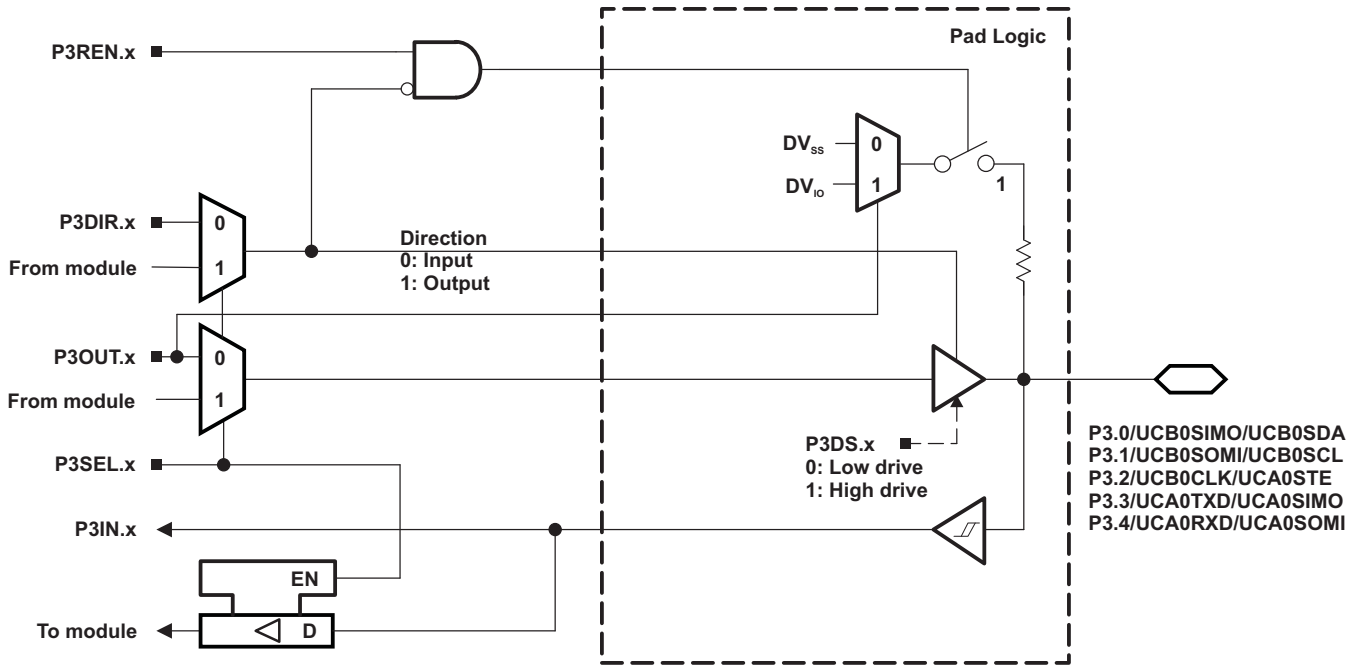

Table 54. Port P3 (P3.0 to P3.4) Pin Functions

PIN NAME (P3.x)	x	FUNCTION	CONTROL BITS AND SIGNALS ⁽¹⁾	
			P3DIR.x	P3SEL.x
P3.0/UCB0SIMO/UCB0SDA	0	P3.0 (I/O)	I: 0; O: 1	0
		UCB0SIMO/UCB0SDA ^{(2) (3)}	X	1
P3.1/UCB0SOMI/UCB0SCL	1	P3.1 (I/O)	I: 0; O: 1	0
		UCB0SOMI/UCB0SCL ^{(2) (3)}	X	1
P3.2/UCB0CLK/UCA0STE	2	P3.2 (I/O)	I: 0; O: 1	0
		UCB0CLK/UCA0STE ^{(2) (4)}	X	1
P3.3/UCA0TXD/UCA0SIMO	3	P3.3 (I/O)	I: 0; O: 1	0
		UCA0TXD/UCA0SIMO ⁽²⁾	X	1
P3.4/UCA0RXD/UCA0SOMI	4	P3.4 (I/O)	I: 0; O: 1	0
		UCA0RXD/UCA0SOMI ⁽²⁾	X	1

- (1) X = Don't care
- (2) The pin direction is controlled by the USCI module.
- (3) If the I2C functionality is selected, the output drives only the logical 0 to V_{SS} level.
- (4) UCB0CLK function takes precedence over UCA0STE function. If the pin is required as UCB0CLK input or output, USCI_A0 is forced to 3-wire SPI mode if 4-wire SPI mode is selected.

PRODUCT PREVIEW

Port P4, P4.0 to P4.7, Input/Output With Schmitt Trigger

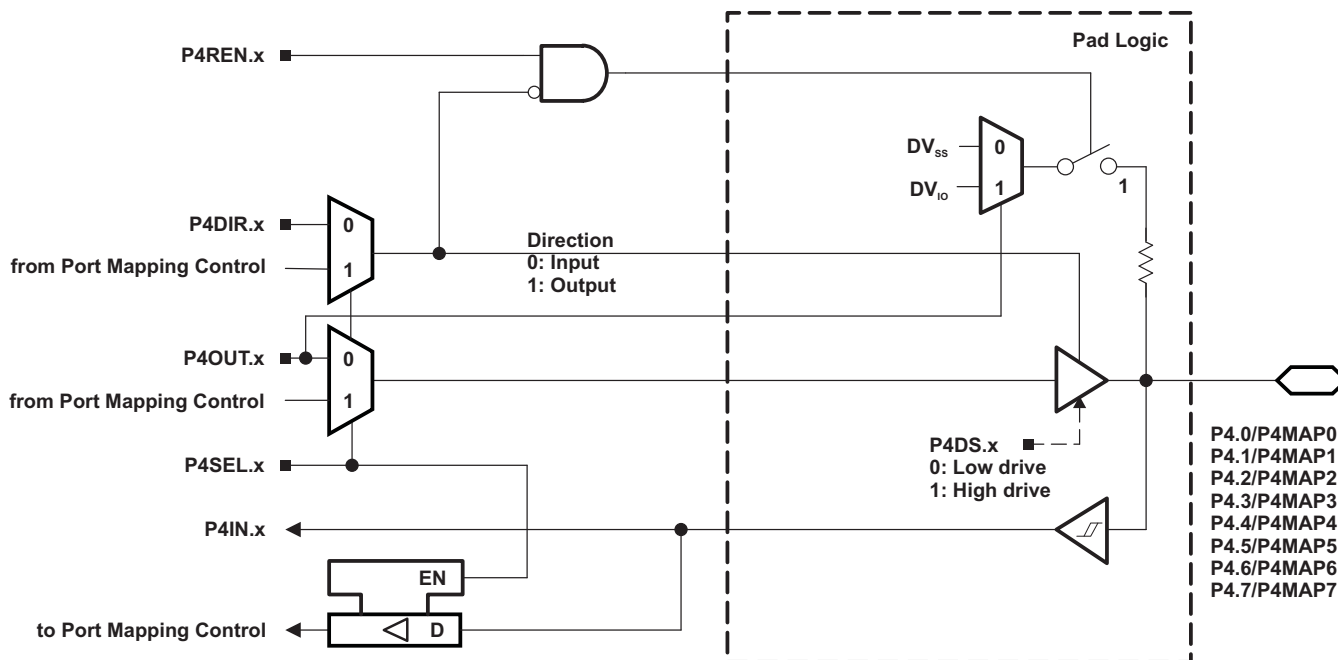

Table 55. Port P4 (P4.0 to P4.7) Pin Functions

PIN NAME (P4.x)	x	FUNCTION	CONTROL BITS AND SIGNALS ⁽¹⁾		
			P4DIR.x ⁽²⁾	P4SEL.x	P4MAPx
P4.0/P4MAP0	0	P4.0 (I/O)	I: 0; O: 1	0	X
		Mapped secondary digital function	X	1	≤ 30
P4.1/P4MAP1	1	P4.1 (I/O)	I: 0; O: 1	0	X
		Mapped secondary digital function	X	1	≤ 30
P4.2/P4MAP2	2	P4.2 (I/O)	I: 0; O: 1	0	X
		Mapped secondary digital function	X	1	≤ 30
P4.3/P4MAP3	3	P4.3 (I/O)	I: 0; O: 1	0	X
		Mapped secondary digital function	X	1	≤ 30
P4.4/P4MAP4	4	P4.4 (I/O)	I: 0; O: 1	0	X
		Mapped secondary digital function	X	1	≤ 30
P4.5/P4MAP5	5	P4.5 (I/O)	I: 0; O: 1	0	X
		Mapped secondary digital function	X	1	≤ 30
P4.6/P4MAP6	6	P4.6 (I/O)	I: 0; O: 1	0	X
		Mapped secondary digital function	X	1	≤ 30
P4.7/P4MAP7	7	P4.7 (I/O)	I: 0; O: 1	0	X
		Mapped secondary digital function	X	1	≤ 30

(1) X = Don't care

(2) The direction of some mapped secondary functions are controlled directly by the module. See Table 11 for specific direction control information of mapped secondary functions.

Port P5, P5.0 and P5.1, Input/Output With Schmitt Trigger

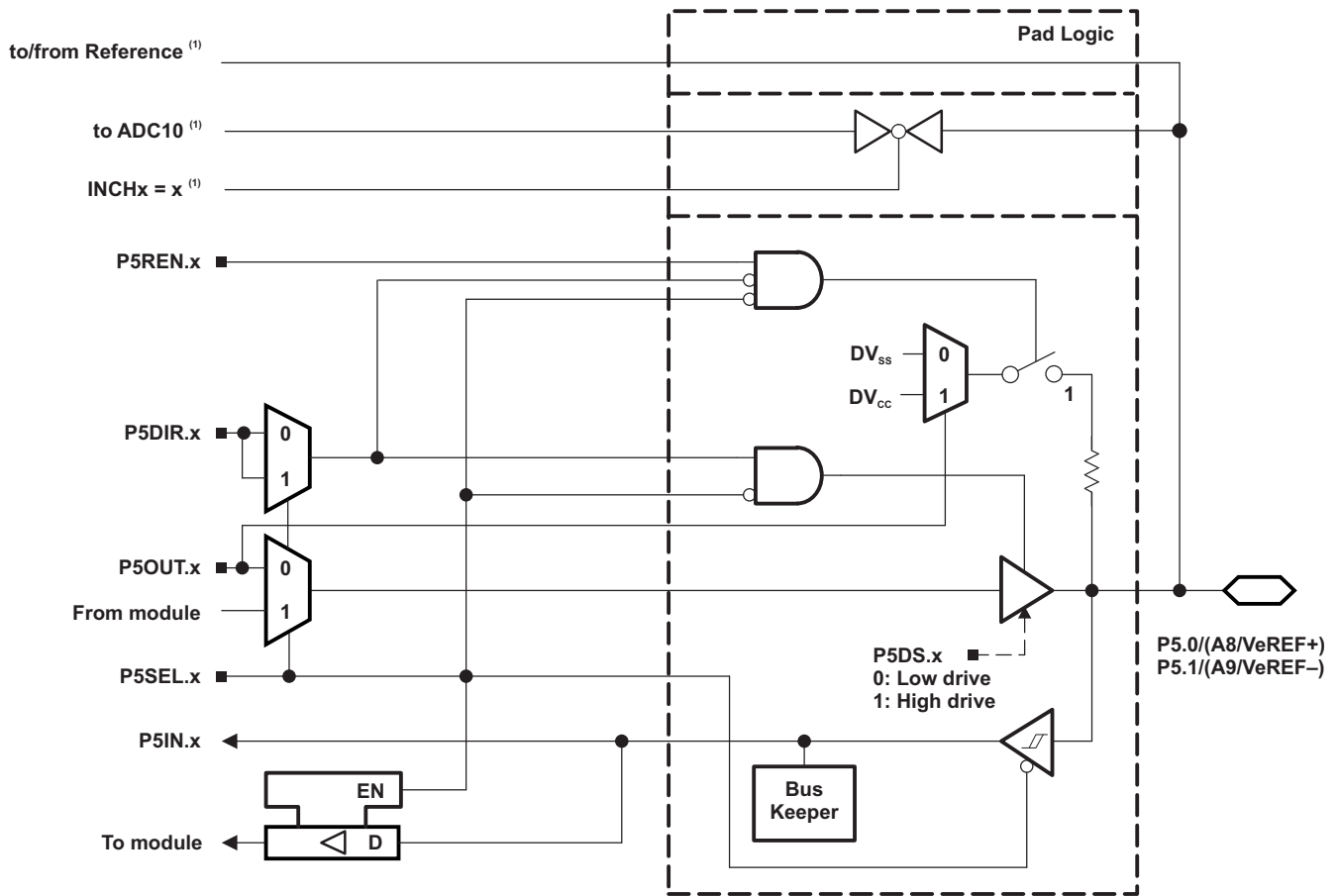

(1) not available for MSP430F5258
MSP430F5256
MSP430F5254
MSP430F5252

Table 56. Port P5 (P5.0 and P5.1) Pin Functions

PIN NAME (P5.x)	x	FUNCTION	CONTROL BITS AND SIGNALS ⁽¹⁾		
			P5DIR.x	P5SEL.x	REFOUT ⁽²⁾
P5.0/A8/VeREF+	0	P5.0 (I/O) ⁽³⁾	I: 0; O: 1	0	X
		A8/VeREF+ ⁽⁴⁾	X	1	0
P5.1/A9/VeREF-	1	P5.1 (I/O) ⁽³⁾	I: 0; O: 1	0	X
		A9/VeREF- ⁽⁵⁾	X	1	0

- (1) X = Don't care
- (2) REFOUT resides in the REF module.
- (3) Default condition
- (4) Setting the P5SEL.0 bit disables the output driver and the input Schmitt trigger to prevent parasitic cross currents when applying analog signals. An external voltage can be applied to VeREF+ and used as the reference for the ADC10_A. Channel A8, when selected with the INCHx bits, is connected to the VeREF+ pin.
- (5) Setting the P5SEL.1 bit disables the output driver and the input Schmitt trigger to prevent parasitic cross currents when applying analog signals. An external voltage can be applied to VeREF- and used as the reference for the ADC10_A. Channel A9, when selected with the INCHx bits, is connected to the VeREF- pin.

PRODUCT PREVIEW

Port P5, P5.2, Input/Output With Schmitt Trigger

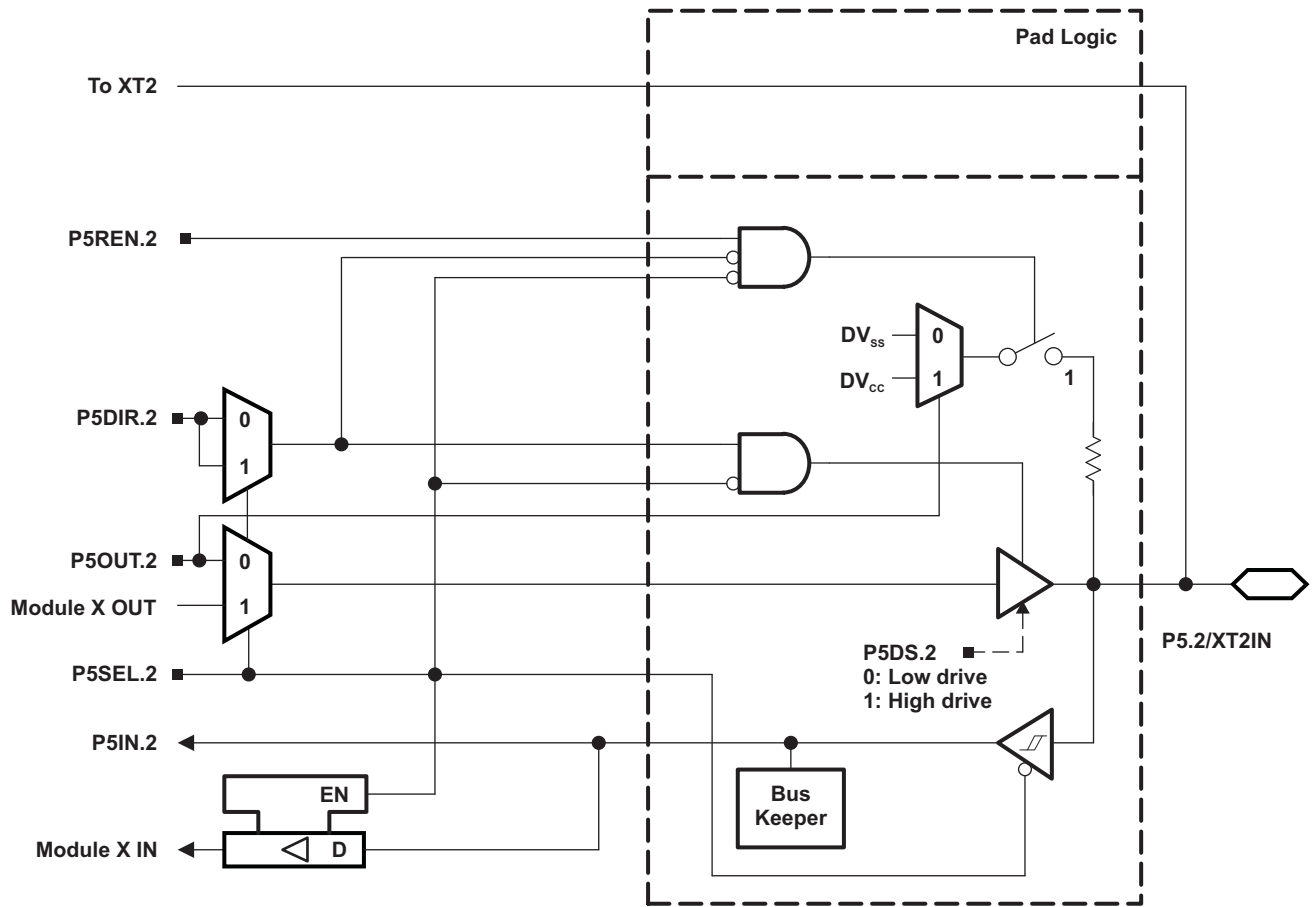

PRODUCT PREVIEW

Port P5, P5.3, Input/Output With Schmitt Trigger

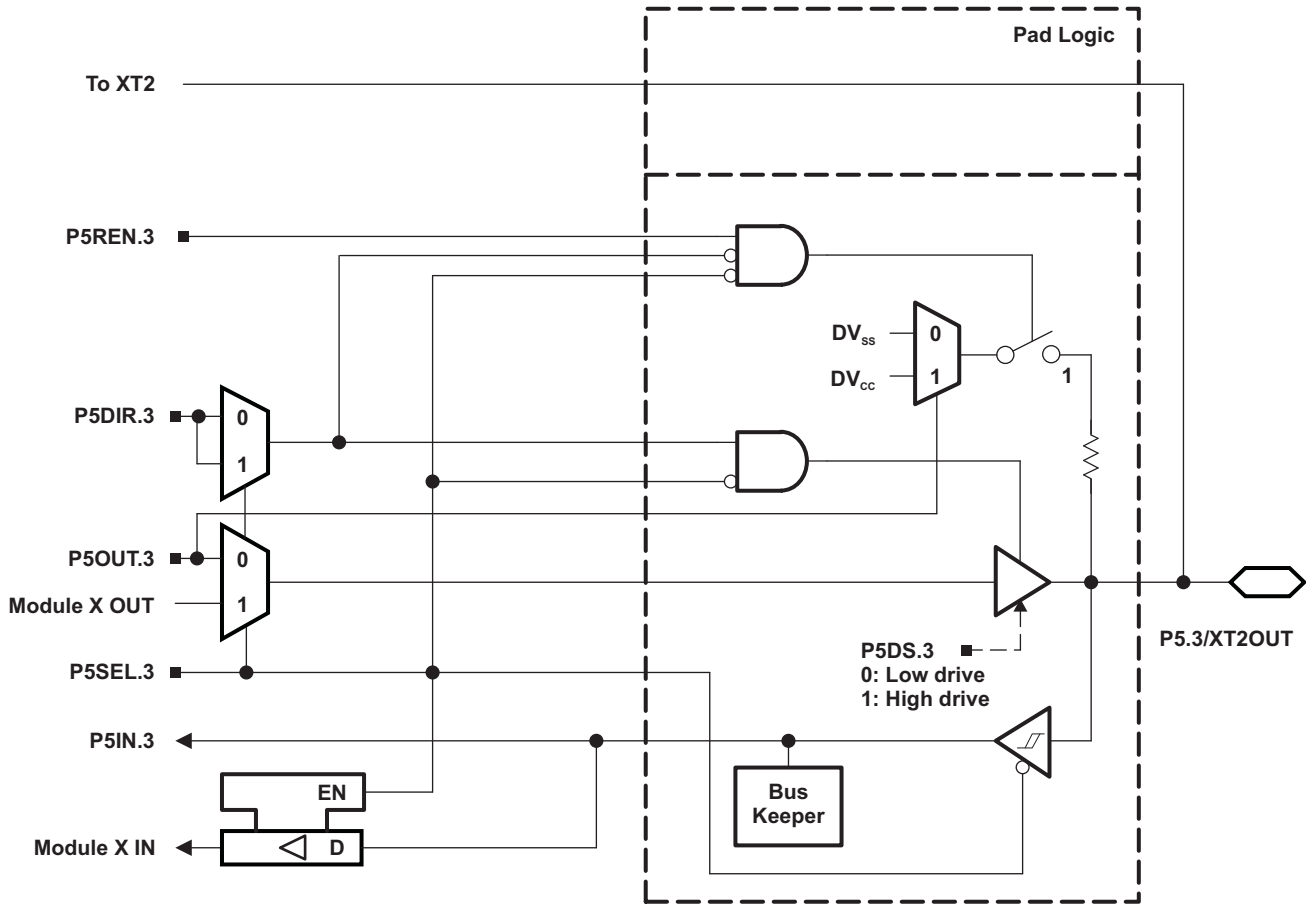

Table 57. Port P5 (P5.2, P5.3) Pin Functions

PIN NAME (P5.x)	x	FUNCTION	CONTROL BITS AND SIGNALS ⁽¹⁾			
			P5DIR.x	P5SEL.2	P5SEL.3	XT2BYPASS
P5.2/XT2IN	2	P5.2 (I/O)	I: 0; O: 1	0	X	X
		XT2IN crystal mode ⁽²⁾	X	1	X	0
		XT2IN bypass mode ⁽²⁾	X	1	X	1
P5.3/XT2OUT	3	P5.3 (I/O)	I: 0; O: 1	0	X	X
		XT2OUT crystal mode ⁽³⁾	X	1	X	0
		P5.3 (I/O) ⁽³⁾	X	1	X	1

(1) X = Don't care

(2) Setting P5SEL.2 causes the general-purpose I/O to be disabled. Pending the setting of XT2BYPASS, P5.2 is configured for crystal mode or bypass mode.

(3) Setting P5SEL.2 causes the general-purpose I/O to be disabled in crystal mode. When using bypass mode, P5.3 can be used as general-purpose I/O.

Port P5, P5.4 and P5.5 Input/Output With Schmitt Trigger

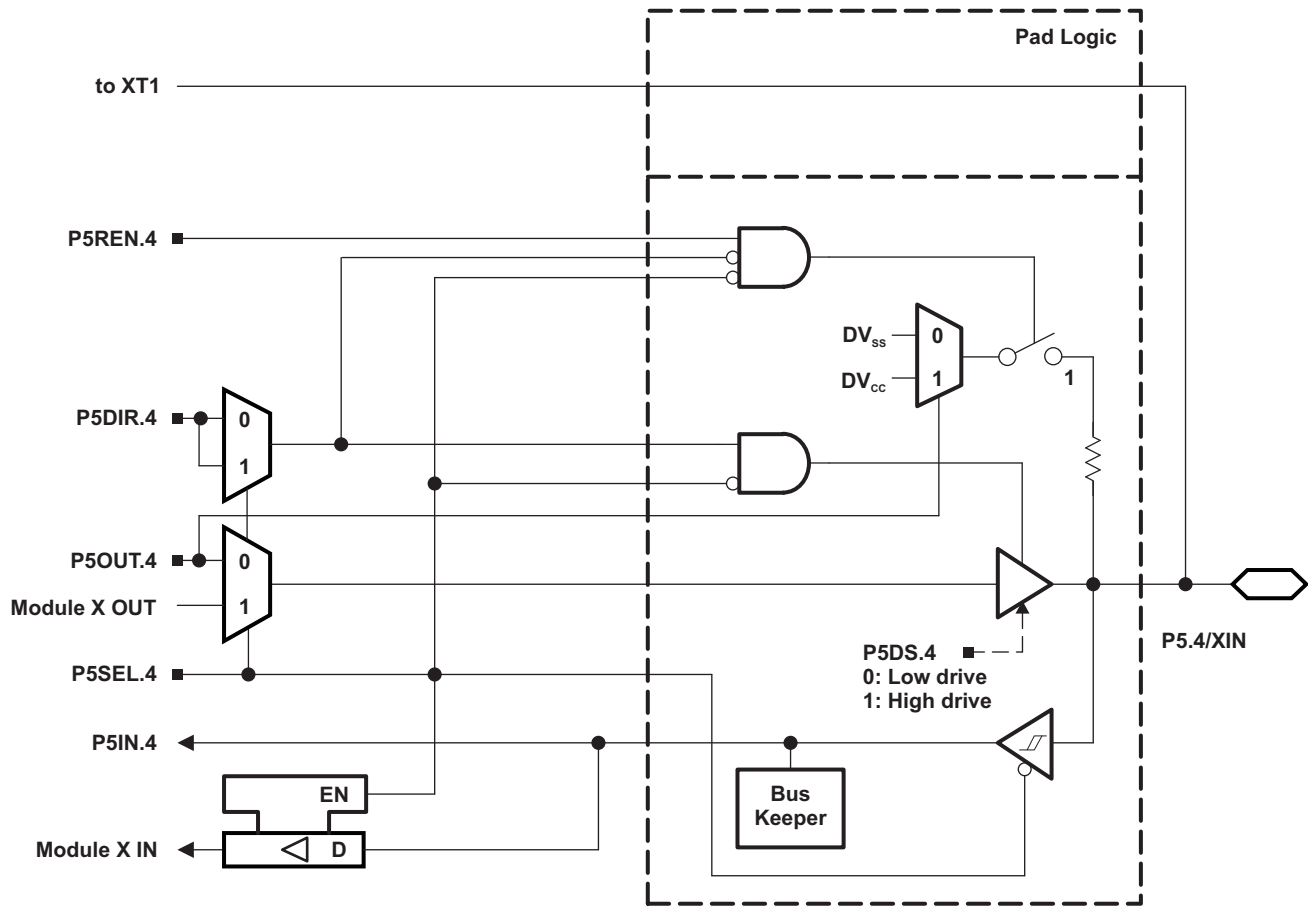

PRODUCT PREVIEW

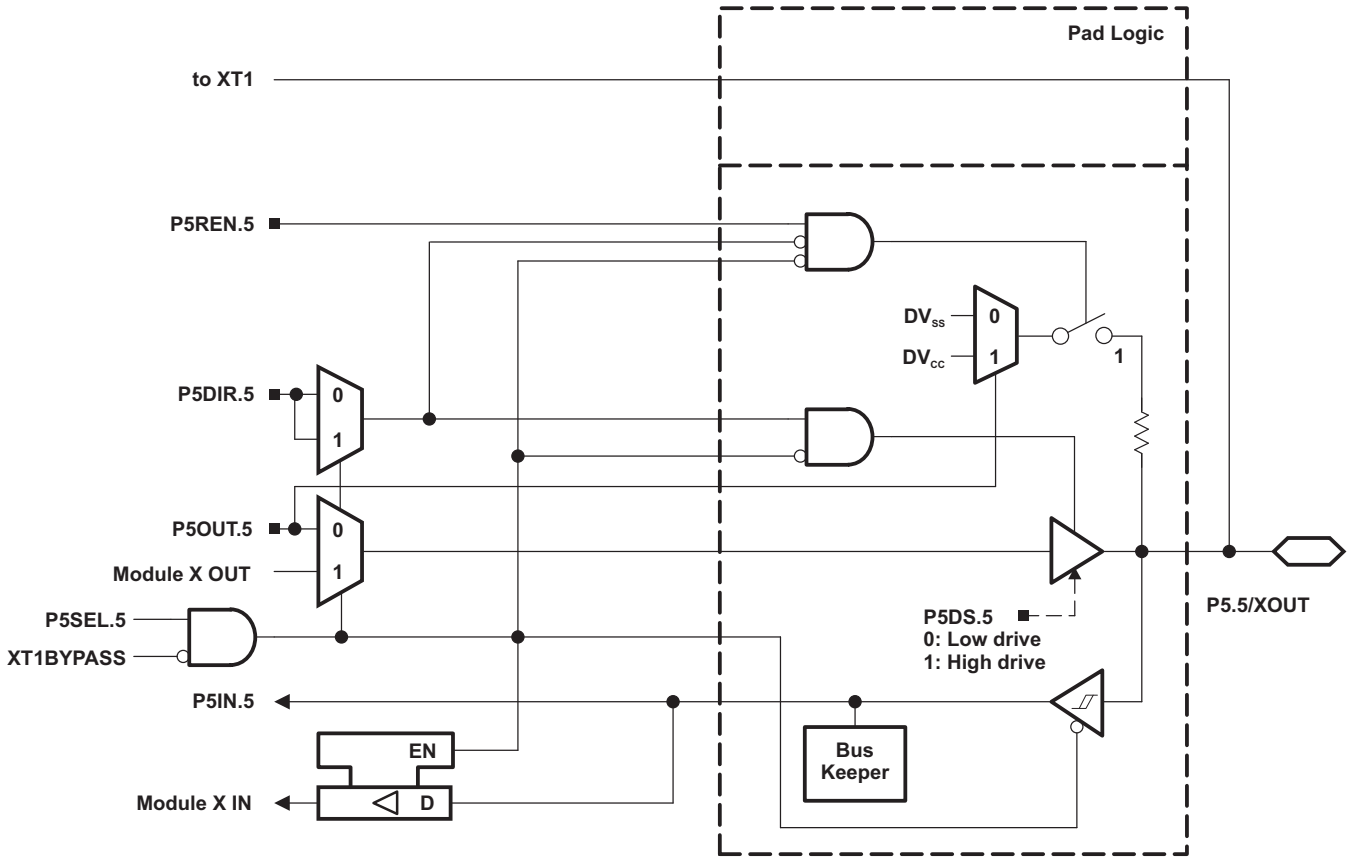

Table 58. Port P5 (P5.4 and P5.5) Pin Functions

PIN NAME (P5.x)	x	FUNCTION	CONTROL BITS AND SIGNALS ⁽¹⁾			
			P5DIR.x	P5SEL.4	P5SEL.5	XT1BYPASS
P5.4/XIN	4	P5.4 (I/O)	I: 0; O: 1	0	X	X
		XIN crystal mode ⁽²⁾	X	1	X	0
		XIN bypass mode ⁽²⁾	X	1	X	1
P5.5/XOUT	5	P5.5 (I/O)	I: 0; O: 1	0	X	X
		XOUT crystal mode ⁽³⁾	X	1	X	0
		P5.5 (I/O) ⁽³⁾	X	1	X	1

- (1) X = Don't care
- (2) Setting P5SEL.4 causes the general-purpose I/O to be disabled. Pending the setting of XT1BYPASS, P5.4 is configured for crystal mode or bypass mode.
- (3) Setting P5SEL.4 causes the general-purpose I/O to be disabled in crystal mode. When using bypass mode, P5.5 can be used as general-purpose I/O.

PRODUCT PREVIEW

Port P6, P6.0 to P6.7, Input/Output With Schmitt Trigger

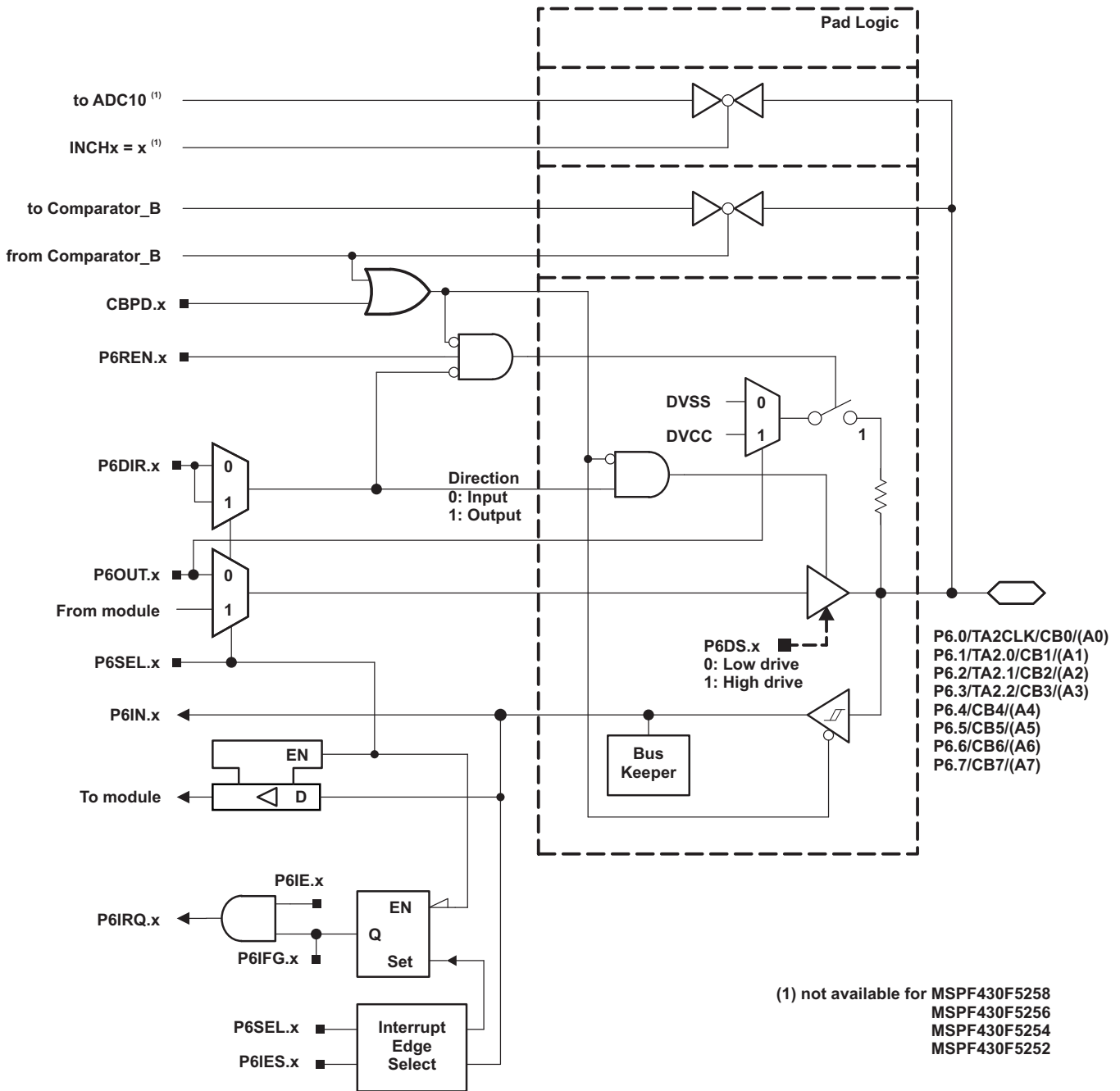

PRODUCT PREVIEW

Table 59. Port P6 (P6.0 to P6.7) Pin Functions

PIN NAME (P6.x)	x	FUNCTION	CONTROL BITS AND SIGNALS		
			P6DIR.x	P6SEL.x	CBPD
P6.0/TA2CLK/SMCLK/CB0/(A0)	0	P6.0 (I/O)	I: 0; O: 1	0	0
		TA2CLK	0	1	0
		SMCLK	1	1	0
		A0	X	X	1
		CB0 ⁽¹⁾	X	X	1
P6.1/TA2.0/CB1/(A1)	1	P6.1 (I/O)	I: 0; O: 1	0	0
		TA2.CCI0A	0	1	0
		TA2.0	1	1	0
		A1	X	X	1
		CB1 ⁽¹⁾	X	X	1
P6.2/TA2.1/CB2/(A2)	2	P6.2 (I/O)	I: 0; O: 1	0	0
		TA2.CCI1A	0	1	0
		TA2.1	1	1	0
		A2	X	X	1
		CB2 ⁽¹⁾	X	X	1
P6.3/TA2.1/CB3/(A3)	3	P6.3 (I/O)	I: 0; O: 1	0	0
		TA2.CCI2A	0	1	0
		TA2.2	1	1	0
		A3	X	X	1
		CB3 ⁽¹⁾	X	X	1
P6.4/CB4/(A4)	4	P6.4 (I/O)	I: 0; O: 1	0	0
		A4	X	X	1
		CB4 ⁽¹⁾	X	X	1
P6.5/CB5/(A5)	5	P6.5 (I/O)	I: 0; O: 1	0	0
		A5	X	X	1
		CB5 ⁽¹⁾	X	X	1
P6.6/CB6/(A6)	6	P6.6 (I/O)	I: 0; O: 1	0	0
		A6	X	X	1
		CB6 ⁽¹⁾	X	X	1
P6.7/CB7/(A7)	7	P6.7 (I/O)	I: 0; O: 1	0	0
		A7	X	X	1
		CB7 ⁽¹⁾	X	X	1

(1) Setting the CBPD.x bit disables the output driver and the input Schmitt trigger to prevent parasitic cross currents when applying analog signals. Selecting the CBx input pin to the comparator multiplexer with the CBx bits automatically disables output driver and input buffer for that pin, regardless of the state of the associated CBPD.x bit.

Port P7, P7.0 to P7.5, Input/Output With Schmitt Trigger

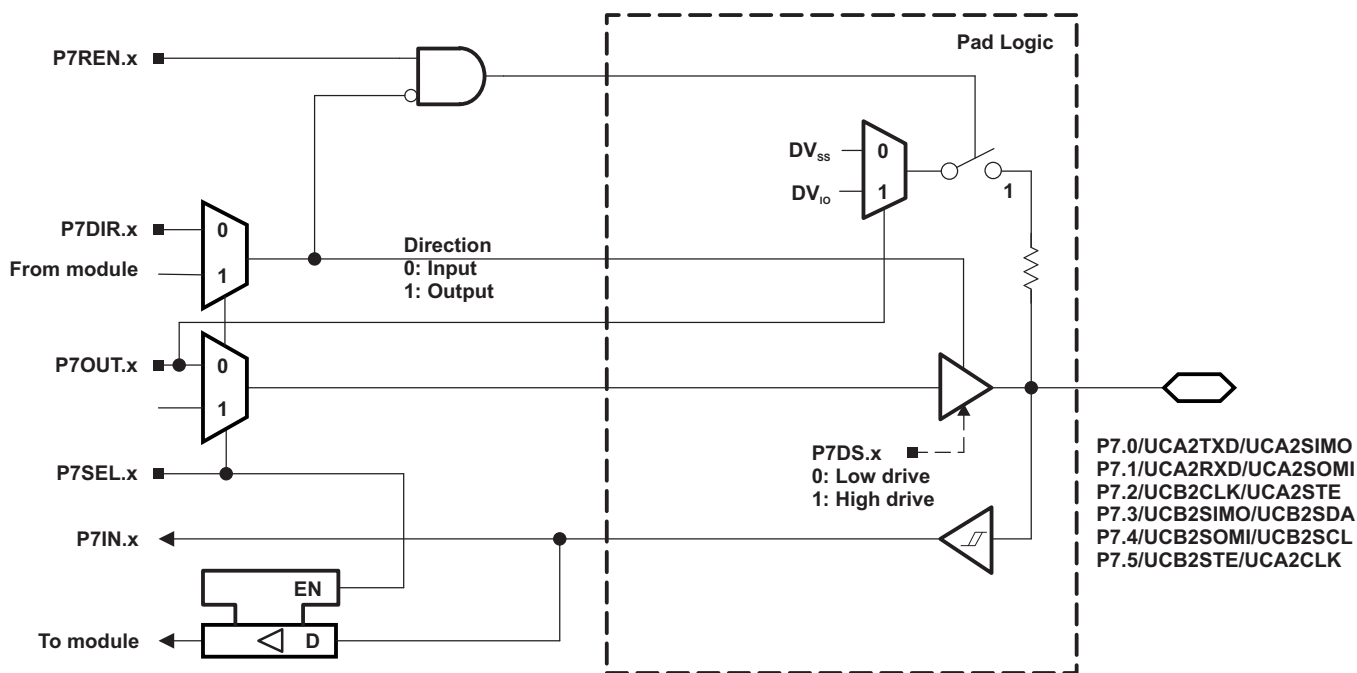

Table 60. Port P7 (P7.0 to P7.5) Pin Functions

PIN NAME (P7.x)	x	FUNCTION	CONTROL BITS AND SIGNALS	
			P7DIR.x	P7SEL.x
P7.0/UCA2TXD/UCA2SIMO	0	P7.0 (I/O)	I: 0; O: 1	0
		UCA2TXD/UCA2SIMO ⁽¹⁾	X	1
P7.1/UCA2RXD/UCA2SOMI	1	P7.1 (I/O)	I: 0; O: 1	0
		UCA2RXD/UCA2SOMI ⁽¹⁾	X	1
P7.2/UCB2CLK/UCA2STE	2	P7.2 (I/O)	I: 0; O: 1	0
		UCB2CLK/UCA2STE ^{(1) (2)}	X	1
P7.3/UCB2SIMO/UCB2SDA	3	P7.3 (I/O)	I: 0; O: 1	0
		UCB2SIMO/UCB2SDA ^{(1) (3)}	X	1
P7.4/UCB2SOMI/UCB2SCL	4	P7.4 (I/O)	I: 0; O: 1	0
		UCB2SOMI/UCB2SCL ^{(1) (3)}	X	1
P7.5/UCB2STE/UCA2CLK	5	P7.5 (I/O)	I: 0; O: 1	0
		UCB2STE/UCA2CLK ⁽¹⁾	X	1

- (1) Setting P7SEL.x bit disables the output driver and the input Schmitt trigger.
- (2) UCB2CLK function takes precedence over UCA2STE function. If the pin is required as UCB2CLK input or output, USCI_A2 is forced to 3-wire SPI mode if 4-wire SPI mode is selected.
- (3) If the I2C functionality is selected, the output drives only the logical 0 to V_{SS} level.

PRODUCT PREVIEW

Port J, J.0 JTAG pin TDO, Input/Output With Schmitt Trigger or Output

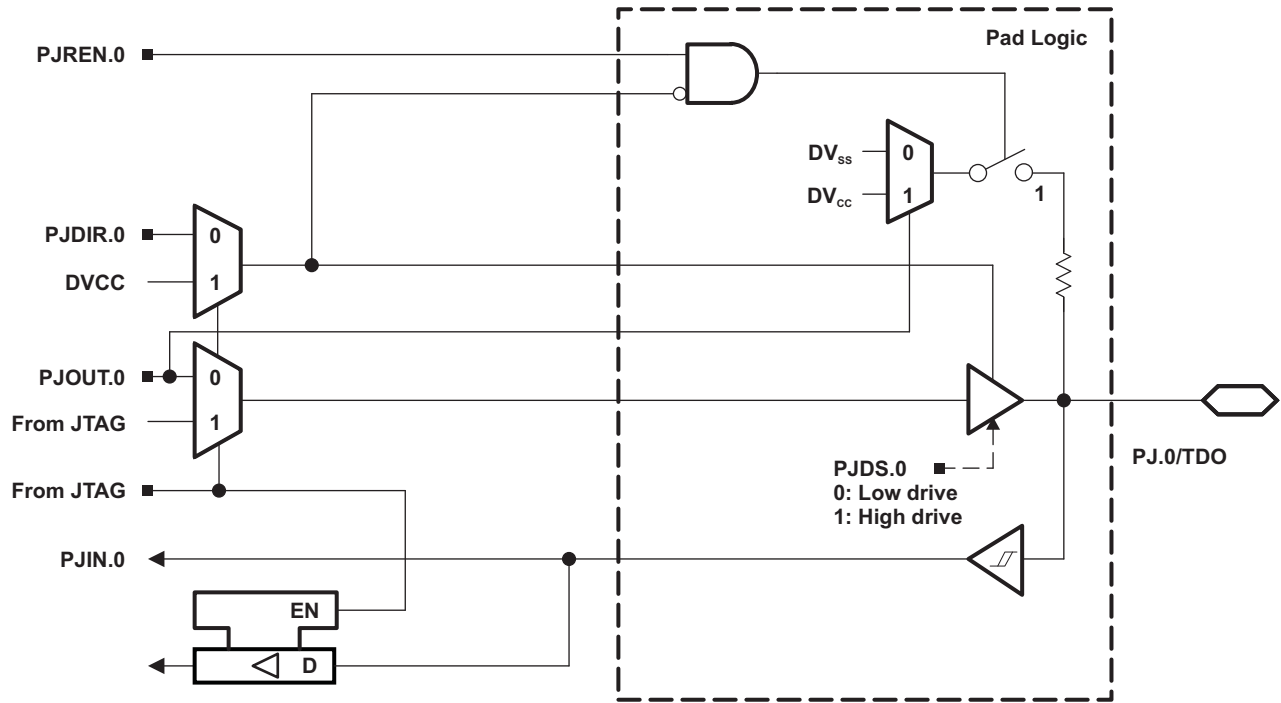

Port J, J.1 to J.3 JTAG pins TMS, TCK, TDI/TCLK, Input/Output With Schmitt Trigger or Output

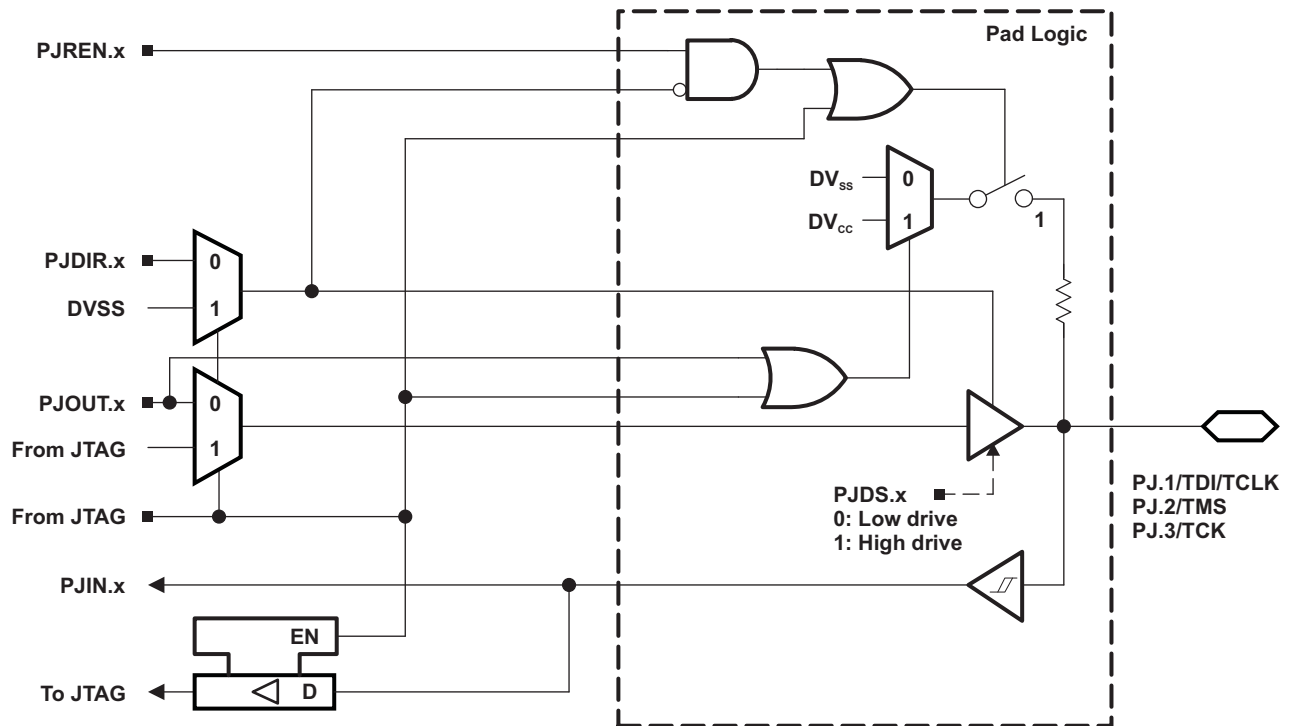

PRODUCT PREVIEW

Table 61. Port PJ (PJ.0 to PJ.3) Pin Functions

PIN NAME (PJ.x)	x	FUNCTION	CONTROL BITS AND SIGNALS ⁽¹⁾
			PJDIR.x
PJ.0/TDO	0	PJ.0 (I/O) ⁽²⁾	I: 0; O: 1
		TDO ⁽³⁾	X
PJ.1/TDI/TCLK	1	PJ.1 (I/O) ⁽²⁾	I: 0; O: 1
		TDI/TCLK ^{(3) (4)}	X
PJ.2/TMS	2	PJ.2 (I/O) ⁽²⁾	I: 0; O: 1
		TMS ^{(3) (4)}	X
PJ.3/TCK	3	PJ.3 (I/O) ⁽²⁾	I: 0; O: 1
		TCK ^{(3) (4)}	X

- (1) X = Don't care
- (2) Default condition
- (3) The pin direction is controlled by the JTAG module.
- (4) In JTAG mode, pullups are activated automatically on TMS, TCK, and TDI/TCLK. PJREN.x are do not care.

DEVICE DESCRIPTORS

Table 62 and Table 63 list the complete contents of the device descriptor tag-length-value (TLV) structure for each device type.

Table 62. MSP430F5259, MSP430F5257, MSP430F5255, MSP430F5253 Device Descriptor Table⁽¹⁾

	Description	Address	Size (bytes)	F5259	F5257	F5255	F5253
				Value	Value	Value	Value
Info Block	Info length	01A00h	1	06h	06h	06h	06h
	CRC length	01A01h	1	06h	06h	06h	06h
	CRC value	01A02h	2	per unit	per unit	per unit	per unit
	Device ID	01A04h	1	FF	01	03	05
	Device ID	01A05h	1	81	82	82	82
	Hardware revision	01A06h	1	per unit	per unit	per unit	per unit
	Firmware revision	01A07h	1	per unit	per unit	per unit	per unit
Die Record	Die Record Tag	01A08h	1	08h	08h	08h	08h
	Die Record length	01A09h	1	0Ah	0Ah	0Ah	0Ah
	Lot/Wafer ID	01A0Ah	4	per unit	per unit	per unit	per unit
	Die X position	01A0Eh	2	per unit	per unit	per unit	per unit
	Die Y position	01A10h	2	per unit	per unit	per unit	per unit
	Test results	01A12h	2	per unit	per unit	per unit	per unit
ADC10 Calibration	ADC10 Calibration Tag	01A14h	1	13h	13h	13h	13h
	ADC10 Calibration length	01A15h	1	10h	10h	10h	10h
	ADC Gain Factor	01A16h	2	per unit	per unit	per unit	per unit
	ADC Offset	01A18h	2	per unit	per unit	per unit	per unit
	ADC 1.5-V Reference Temp. Sensor 30°C	01A1Ah	2	per unit	per unit	per unit	per unit
	ADC 1.5-V Reference Temp. Sensor 85°C	01A1Ch	2	per unit	per unit	per unit	per unit
	ADC 2.0-V Reference Temp. Sensor 30°C	01A1Eh	2	per unit	per unit	per unit	per unit
	ADC 2.0-V Reference Temp. Sensor 85°C	01A20h	2	per unit	per unit	per unit	per unit
	ADC 2.5-V Reference Temp. Sensor 30°C	01A22h	2	per unit	per unit	per unit	per unit
	ADC 2.5-V Reference Temp. Sensor 85°C	01A24h	2	per unit	per unit	per unit	per unit
	REF Calibration	REF Calibration Tag	01A26h	1	12h	12h	12h
REF Calibration length		01A27h	1	06h	06h	06h	06h
REF 1.5-V Reference Factor		01A28h	2	per unit	per unit	per unit	per unit
REF 2.0-V Reference Factor		01A2Ah	2	per unit	per unit	per unit	per unit
REF 2.5-V Reference Factor		01A2Ch	2	per unit	per unit	per unit	per unit

(1) NA = Not applicable, blank = unused and reads FFh.

Table 63. MSP430F5258, MSP430F5256, MSP430F5254, MSP430F5252 Device Descriptor Table⁽¹⁾

	Description	Address	Size (bytes)	F5258	F5256	F5254	F5252
				Value	Value	Value	Value
Info Block	Info length	01A00h	1	06h	06h	06h	06h
	CRC length	01A01h	1	06h	06h	06h	06h
	CRC value	01A02h	2	per unit	per unit	per unit	per unit

(1) NA = Not applicable, blank = unused and reads FFh.

**Table 63. MSP430F5258, MSP430F5256, MSP430F5254, MSP430F5252 Device Descriptor Table⁽¹⁾
(continued)**

	Description	Address	Size (bytes)	F5258	F5256	F5254	F5252
				Value	Value	Value	Value
	Device ID	01A04h	1	00	02	04	06
	Device ID	01A05h	1	82	82	82	82
	Hardware revision	01A06h	1	per unit	per unit	per unit	per unit
	Firmware revision	01A07h	1	per unit	per unit	per unit	per unit
Die Record	Die Record Tag	01A08h	1	08h	08h	08h	08h
	Die Record length	01A09h	1	0Ah	0Ah	0Ah	0Ah
	Lot/Wafer ID	01A0Ah	4	per unit	per unit	per unit	per unit
	Die X position	01A0Eh	2	per unit	per unit	per unit	per unit
	Die Y position	01A10h	2	per unit	per unit	per unit	per unit
	Test results	01A12h	2	per unit	per unit	per unit	per unit
ADC10 Calibration	ADC10 Calibration Tag	01A14h	1	13h	13h	13h	13h
	ADC10 Calibration length	01A15h	1	10h	10h	10h	10h
	ADC Gain Factor	01A16h	2	blank	blank	blank	blank
	ADC Offset	01A18h	2	blank	blank	blank	blank
	ADC 1.5-V Reference Temp. Sensor 30°C	01A1Ah	2	blank	blank	blank	blank
	ADC 1.5-V Reference Temp. Sensor 85°C	01A1Ch	2	blank	blank	blank	blank
	ADC 2.0-V Reference Temp. Sensor 30°C	01A1Eh	2	blank	blank	blank	blank
	ADC 2.0-V Reference Temp. Sensor 85°C	01A20h	2	blank	blank	blank	blank
	ADC 2.5-V Reference Temp. Sensor 30°C	01A22h	2	blank	blank	blank	blank
	ADC 2.5-V Reference Temp. Sensor 85°C	01A24h	2	blank	blank	blank	blank
REF Calibration	REF Calibration Tag	01A26h	1	12h	12h	12h	12h
	REF Calibration length	01A27h	1	06h	06h	06h	06h
	REF 1.5-V Reference Factor	01A28h	2	per unit	per unit	per unit	per unit
	REF 2.0-V Reference Factor	01A2Ah	2	per unit	per unit	per unit	per unit
	REF 2.5-V Reference Factor	01A2Ch	2	per unit	per unit	per unit	per unit

PRODUCT PREVIEW

REVISION HISTORY

REVISION	CHANGES
SLAS903	Product Preview release
SLAS903A	Updated Product Preview release. Added Applications . Changed Description . Added Development Tools Support and Device and Development Tool Nomenclature .

PRODUCT PREVIEW

PACKAGING INFORMATION

Orderable Device	Status (1)	Package Type	Package Drawing	Pins	Package Qty	Eco Plan (2)	Lead/Ball Finish	MSL Peak Temp (3)	Op Temp (°C)	Device Marking (4/5)	Samples
MSP430F5252IRGCR	ACTIVE	VQFN	RGC	64	2000	Green (RoHS & no Sb/Br)	CU NIPDAU	Level-3-260C-168 HR	-40 to 85	F5252	Samples
MSP430F5252IRGCT	ACTIVE	VQFN	RGC	64	250	Green (RoHS & no Sb/Br)	CU NIPDAU	Level-3-260C-168 HR	-40 to 85	F5252	Samples
MSP430F5252IZQE	ACTIVE	BGA MICROSTAR JUNIOR	ZQE	80	360	Green (RoHS & no Sb/Br)	SNAGCU	Level-3-260C-168 HR	-40 to 85	F5252	Samples
MSP430F5252IZQER	ACTIVE	BGA MICROSTAR JUNIOR	ZQE	80	2500	Green (RoHS & no Sb/Br)	SNAGCU	Level-3-260C-168 HR	-40 to 85	F5252	Samples
MSP430F5253IRGCR	ACTIVE	VQFN	RGC	64	2000	Green (RoHS & no Sb/Br)	CU NIPDAU	Level-3-260C-168 HR	-40 to 85	F5253	Samples
MSP430F5253IRGCT	ACTIVE	VQFN	RGC	64	250	Green (RoHS & no Sb/Br)	CU NIPDAU	Level-3-260C-168 HR	-40 to 85	F5253	Samples
MSP430F5253IZQE	ACTIVE	BGA MICROSTAR JUNIOR	ZQE	80	360	Green (RoHS & no Sb/Br)	SNAGCU	Level-3-260C-168 HR	-40 to 85	F5253	Samples
MSP430F5253IZQER	ACTIVE	BGA MICROSTAR JUNIOR	ZQE	80	2500	Green (RoHS & no Sb/Br)	SNAGCU	Level-3-260C-168 HR	-40 to 85	F5253	Samples
MSP430F5254IRGCR	ACTIVE	VQFN	RGC	64	2000	Green (RoHS & no Sb/Br)	CU NIPDAU	Level-3-260C-168 HR	-40 to 85	F5254	Samples
MSP430F5254IRGCT	ACTIVE	VQFN	RGC	64	250	Green (RoHS & no Sb/Br)	CU NIPDAU	Level-3-260C-168 HR	-40 to 85	F5254	Samples
MSP430F5254IZQE	ACTIVE	BGA MICROSTAR JUNIOR	ZQE	80	360	Green (RoHS & no Sb/Br)	SNAGCU	Level-3-260C-168 HR	-40 to 85	F5254	Samples
MSP430F5254IZQER	ACTIVE	BGA MICROSTAR JUNIOR	ZQE	80	2500	Green (RoHS & no Sb/Br)	SNAGCU	Level-3-260C-168 HR	-40 to 85	F5254	Samples
MSP430F5255IRGCR	ACTIVE	VQFN	RGC	64	2000	Green (RoHS & no Sb/Br)	CU NIPDAU	Level-3-260C-168 HR	-40 to 85	F5255	Samples
MSP430F5255IRGCT	ACTIVE	VQFN	RGC	64	250	Green (RoHS & no Sb/Br)	CU NIPDAU	Level-3-260C-168 HR	-40 to 85	F5255	Samples

Orderable Device	Status (1)	Package Type	Package Drawing	Pins	Package Qty	Eco Plan (2)	Lead/Ball Finish	MSL Peak Temp (3)	Op Temp (°C)	Device Marking (4/5)	Samples
MSP430F5255IZQE	ACTIVE	BGA MICROSTAR JUNIOR	ZQE	80	360	Green (RoHS & no Sb/Br)	SNAGCU	Level-3-260C-168 HR	-40 to 85	F5255	Samples
MSP430F5255IZQER	ACTIVE	BGA MICROSTAR JUNIOR	ZQE	80	2500	Green (RoHS & no Sb/Br)	SNAGCU	Level-3-260C-168 HR	-40 to 85	F5255	Samples
MSP430F5256IRGCR	ACTIVE	VQFN	RGC	64	2000	Green (RoHS & no Sb/Br)	CU NIPDAU	Level-3-260C-168 HR	-40 to 85	F5256	Samples
MSP430F5256IRGCT	ACTIVE	VQFN	RGC	64	250	Green (RoHS & no Sb/Br)	CU NIPDAU	Level-3-260C-168 HR	-40 to 85	F5256	Samples
MSP430F5256IZQE	ACTIVE	BGA MICROSTAR JUNIOR	ZQE	80	360	Green (RoHS & no Sb/Br)	SNAGCU	Level-3-260C-168 HR	-40 to 85	F5256	Samples
MSP430F5256IZQER	ACTIVE	BGA MICROSTAR JUNIOR	ZQE	80	2500	Green (RoHS & no Sb/Br)	SNAGCU	Level-3-260C-168 HR	-40 to 85	F5256	Samples
MSP430F5257IRGCR	ACTIVE	VQFN	RGC	64	2000	Green (RoHS & no Sb/Br)	CU NIPDAU	Level-3-260C-168 HR	-40 to 85	F5257	Samples
MSP430F5257IRGCT	ACTIVE	VQFN	RGC	64	250	Green (RoHS & no Sb/Br)	CU NIPDAU	Level-3-260C-168 HR	-40 to 85	F5257	Samples
MSP430F5257IZQE	ACTIVE	BGA MICROSTAR JUNIOR	ZQE	80	360	Green (RoHS & no Sb/Br)	SNAGCU	Level-3-260C-168 HR	-40 to 85	F5257	Samples
MSP430F5257IZQER	ACTIVE	BGA MICROSTAR JUNIOR	ZQE	80	2500	Green (RoHS & no Sb/Br)	SNAGCU	Level-3-260C-168 HR	-40 to 85	F5257	Samples
MSP430F5258IRGCR	ACTIVE	VQFN	RGC	64	2000	Green (RoHS & no Sb/Br)	CU NIPDAU	Level-3-260C-168 HR	-40 to 85	F5258	Samples
MSP430F5258IRGCT	ACTIVE	VQFN	RGC	64	250	Green (RoHS & no Sb/Br)	CU NIPDAU	Level-3-260C-168 HR	-40 to 85	F5258	Samples
MSP430F5258IZQE	ACTIVE	BGA MICROSTAR JUNIOR	ZQE	80	360	Green (RoHS & no Sb/Br)	SNAGCU	Level-3-260C-168 HR	-40 to 85	F5258	Samples
MSP430F5258IZQER	ACTIVE	BGA MICROSTAR JUNIOR	ZQE	80	2500	Green (RoHS & no Sb/Br)	SNAGCU	Level-3-260C-168 HR	-40 to 85	F5258	Samples

Orderable Device	Status (1)	Package Type	Package Drawing	Pins	Package Qty	Eco Plan (2)	Lead/Ball Finish	MSL Peak Temp (3)	Op Temp (°C)	Device Marking (4/5)	Samples
MSP430F5259IRGCR	ACTIVE	VQFN	RGC	64	2000	Green (RoHS & no Sb/Br)	CU NIPDAU	Level-3-260C-168 HR	-40 to 85	F5259	Samples
MSP430F5259IRGCT	ACTIVE	VQFN	RGC	64	250	Green (RoHS & no Sb/Br)	CU NIPDAU	Level-3-260C-168 HR	-40 to 85	F5259	Samples
MSP430F5259IZQE	ACTIVE	BGA MICROSTAR JUNIOR	ZQE	80	360	Green (RoHS & no Sb/Br)	SNAGCU	Level-3-260C-168 HR	-40 to 85	F5259	Samples
MSP430F5259IZQER	ACTIVE	BGA MICROSTAR JUNIOR	ZQE	80	2500	Green (RoHS & no Sb/Br)	SNAGCU	Level-3-260C-168 HR	-40 to 85	F5259	Samples

(1) The marketing status values are defined as follows:

ACTIVE: Product device recommended for new designs.

LIFEBUY: TI has announced that the device will be discontinued, and a lifetime-buy period is in effect.

NRND: Not recommended for new designs. Device is in production to support existing customers, but TI does not recommend using this part in a new design.

PREVIEW: Device has been announced but is not in production. Samples may or may not be available.

OBSOLETE: TI has discontinued the production of the device.

(2) Eco Plan - The planned eco-friendly classification: Pb-Free (RoHS), Pb-Free (RoHS Exempt), or Green (RoHS & no Sb/Br) - please check <http://www.ti.com/productcontent> for the latest availability information and additional product content details.

TBD: The Pb-Free/Green conversion plan has not been defined.

Pb-Free (RoHS): TI's terms "Lead-Free" or "Pb-Free" mean semiconductor products that are compatible with the current RoHS requirements for all 6 substances, including the requirement that lead not exceed 0.1% by weight in homogeneous materials. Where designed to be soldered at high temperatures, TI Pb-Free products are suitable for use in specified lead-free processes.

Pb-Free (RoHS Exempt): This component has a RoHS exemption for either 1) lead-based flip-chip solder bumps used between the die and package, or 2) lead-based die adhesive used between the die and leadframe. The component is otherwise considered Pb-Free (RoHS compatible) as defined above.

Green (RoHS & no Sb/Br): TI defines "Green" to mean Pb-Free (RoHS compatible), and free of Bromine (Br) and Antimony (Sb) based flame retardants (Br or Sb do not exceed 0.1% by weight in homogeneous material)

(3) MSL, Peak Temp. -- The Moisture Sensitivity Level rating according to the JEDEC industry standard classifications, and peak solder temperature.

(4) There may be additional marking, which relates to the logo, the lot trace code information, or the environmental category on the device.

(5) Multiple Device Markings will be inside parentheses. Only one Device Marking contained in parentheses and separated by a "~" will appear on a device. If a line is indented then it is a continuation of the previous line and the two combined represent the entire Device Marking for that device.

Important Information and Disclaimer: The information provided on this page represents TI's knowledge and belief as of the date that it is provided. TI bases its knowledge and belief on information provided by third parties, and makes no representation or warranty as to the accuracy of such information. Efforts are underway to better integrate information from third parties. TI has taken and continues to take reasonable steps to provide representative and accurate information but may not have conducted destructive testing or chemical analysis on incoming materials and chemicals. TI and TI suppliers consider certain information to be proprietary, and thus CAS numbers and other limited information may not be available for release.

In no event shall TI's liability arising out of such information exceed the total purchase price of the TI part(s) at issue in this document sold by TI to Customer on an annual basis.

TAPE AND REEL INFORMATION

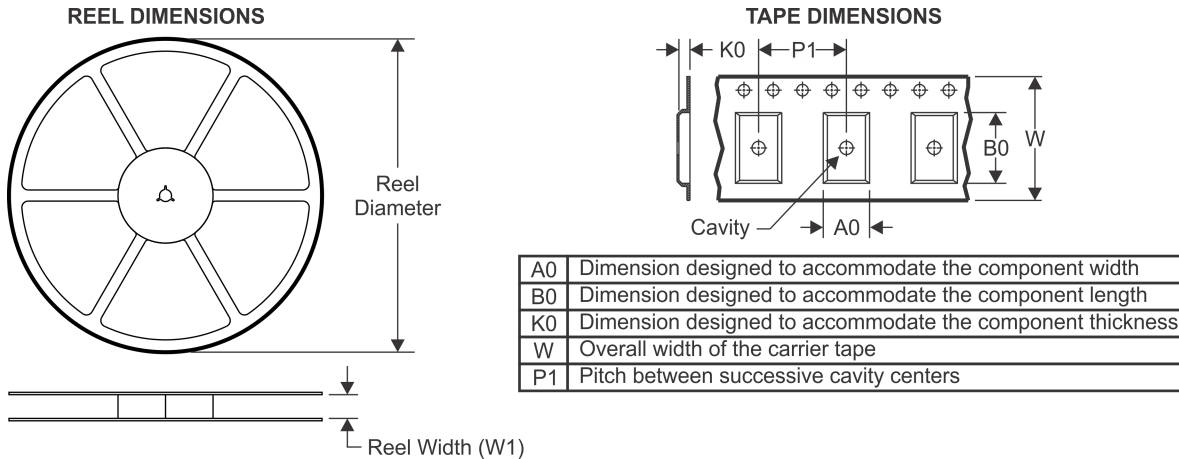

QUADRANT ASSIGNMENTS FOR PIN 1 ORIENTATION IN TAPE

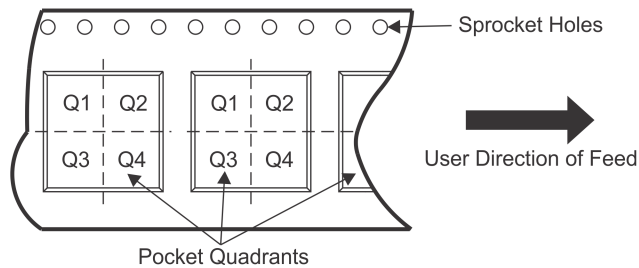

*All dimensions are nominal

Device	Package Type	Package Drawing	Pins	SPQ	Reel Diameter (mm)	Reel Width W1 (mm)	A0 (mm)	B0 (mm)	K0 (mm)	P1 (mm)	W (mm)	Pin1 Quadrant
MSP430F5252IRGCR	VQFN	RGC	64	2000	330.0	16.4	9.3	9.3	1.1	12.0	16.0	Q2
MSP430F5252IRGCT	VQFN	RGC	64	250	180.0	16.4	9.3	9.3	1.1	12.0	16.0	Q2
MSP430F5252IZQER	BGA MICROSTAR JUNIOR	ZQE	80	2500	330.0	12.4	5.3	5.3	1.5	8.0	12.0	Q1
MSP430F5253IRGCR	VQFN	RGC	64	2000	330.0	16.4	9.3	9.3	1.1	12.0	16.0	Q2
MSP430F5253IRGCT	VQFN	RGC	64	250	180.0	16.4	9.3	9.3	1.1	12.0	16.0	Q2
MSP430F5253IZQER	BGA MICROSTAR JUNIOR	ZQE	80	2500	330.0	12.4	5.3	5.3	1.5	8.0	12.0	Q1
MSP430F5254IRGCR	VQFN	RGC	64	2000	330.0	16.4	9.3	9.3	1.1	12.0	16.0	Q2
MSP430F5254IRGCT	VQFN	RGC	64	250	180.0	16.4	9.3	9.3	1.1	12.0	16.0	Q2
MSP430F5254IZQER	BGA MICROSTAR JUNIOR	ZQE	80	2500	330.0	12.4	5.3	5.3	1.5	8.0	12.0	Q1
MSP430F5255IRGCR	VQFN	RGC	64	2000	330.0	16.4	9.3	9.3	1.1	12.0	16.0	Q2
MSP430F5255IRGCT	VQFN	RGC	64	250	180.0	16.4	9.3	9.3	1.1	12.0	16.0	Q2
MSP430F5255IZQER	BGA MI	ZQE	80	2500	330.0	12.4	5.3	5.3	1.5	8.0	12.0	Q1

Device	Package Type	Package Drawing	Pins	SPQ	Reel Diameter (mm)	Reel Width W1 (mm)	A0 (mm)	B0 (mm)	K0 (mm)	P1 (mm)	W (mm)	Pin1 Quadrant
	CROSTAR JUNIOR											
MSP430F5256IRGCR	VQFN	RGC	64	2000	330.0	16.4	9.3	9.3	1.1	12.0	16.0	Q2
MSP430F5256IRGCT	VQFN	RGC	64	250	180.0	16.4	9.3	9.3	1.1	12.0	16.0	Q2
MSP430F5256IZQER	BGA MICROSTAR JUNIOR	ZQE	80	2500	330.0	12.4	5.3	5.3	1.5	8.0	12.0	Q1
MSP430F5257IRGCR	VQFN	RGC	64	2000	330.0	16.4	9.3	9.3	1.1	12.0	16.0	Q2
MSP430F5257IRGCT	VQFN	RGC	64	250	180.0	16.4	9.3	9.3	1.1	12.0	16.0	Q2
MSP430F5257IZQER	BGA MICROSTAR JUNIOR	ZQE	80	2500	330.0	12.4	5.3	5.3	1.5	8.0	12.0	Q1
MSP430F5258IRGCR	VQFN	RGC	64	2000	330.0	16.4	9.3	9.3	1.1	12.0	16.0	Q2
MSP430F5258IRGCT	VQFN	RGC	64	250	180.0	16.4	9.3	9.3	1.1	12.0	16.0	Q2
MSP430F5258IZQER	BGA MICROSTAR JUNIOR	ZQE	80	2500	330.0	12.4	5.3	5.3	1.5	8.0	12.0	Q1
MSP430F5259IRGCR	VQFN	RGC	64	2000	330.0	16.4	9.3	9.3	1.1	12.0	16.0	Q2
MSP430F5259IRGCT	VQFN	RGC	64	250	180.0	16.4	9.3	9.3	1.1	12.0	16.0	Q2
MSP430F5259IZQER	BGA MICROSTAR JUNIOR	ZQE	80	2500	330.0	12.4	5.3	5.3	1.5	8.0	12.0	Q1

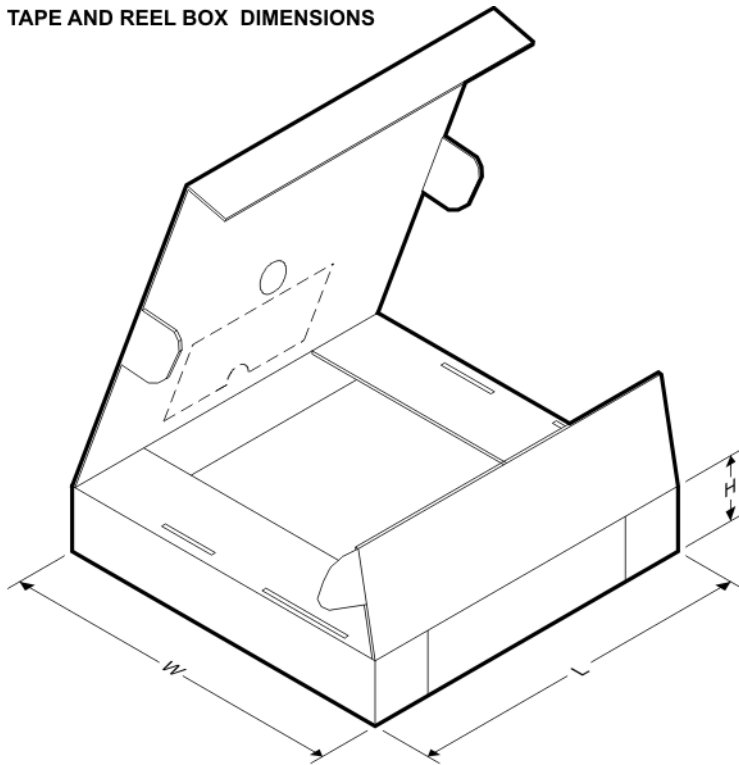
TAPE AND REEL BOX DIMENSIONS

*All dimensions are nominal

Device	Package Type	Package Drawing	Pins	SPQ	Length (mm)	Width (mm)	Height (mm)
MSP430F5252IRGCR	VQFN	RGC	64	2000	367.0	367.0	38.0
MSP430F5252IRGCT	VQFN	RGC	64	250	210.0	185.0	35.0
MSP430F5252IZQER	BGA MICROSTAR JUNIOR	ZQE	80	2500	338.1	338.1	20.6
MSP430F5253IRGCR	VQFN	RGC	64	2000	367.0	367.0	38.0
MSP430F5253IRGCT	VQFN	RGC	64	250	210.0	185.0	35.0
MSP430F5253IZQER	BGA MICROSTAR JUNIOR	ZQE	80	2500	338.1	338.1	20.6
MSP430F5254IRGCR	VQFN	RGC	64	2000	367.0	367.0	38.0
MSP430F5254IRGCT	VQFN	RGC	64	250	210.0	185.0	35.0
MSP430F5254IZQER	BGA MICROSTAR JUNIOR	ZQE	80	2500	338.1	338.1	20.6
MSP430F5255IRGCR	VQFN	RGC	64	2000	367.0	367.0	38.0
MSP430F5255IRGCT	VQFN	RGC	64	250	210.0	185.0	35.0
MSP430F5255IZQER	BGA MICROSTAR JUNIOR	ZQE	80	2500	338.1	338.1	20.6
MSP430F5256IRGCR	VQFN	RGC	64	2000	367.0	367.0	38.0
MSP430F5256IRGCT	VQFN	RGC	64	250	210.0	185.0	35.0
MSP430F5256IZQER	BGA MICROSTAR JUNIOR	ZQE	80	2500	338.1	338.1	20.6
MSP430F5257IRGCR	VQFN	RGC	64	2000	367.0	367.0	38.0
MSP430F5257IRGCT	VQFN	RGC	64	250	210.0	185.0	35.0

Device	Package Type	Package Drawing	Pins	SPQ	Length (mm)	Width (mm)	Height (mm)
MSP430F5257IZQER	BGA MICROSTAR JUNIOR	ZQE	80	2500	338.1	338.1	20.6
MSP430F5258IRGCR	VQFN	RGC	64	2000	367.0	367.0	38.0
MSP430F5258IRGCT	VQFN	RGC	64	250	210.0	185.0	35.0
MSP430F5258IZQER	BGA MICROSTAR JUNIOR	ZQE	80	2500	338.1	338.1	20.6
MSP430F5259IRGCR	VQFN	RGC	64	2000	367.0	367.0	38.0
MSP430F5259IRGCT	VQFN	RGC	64	250	210.0	185.0	35.0
MSP430F5259IZQER	BGA MICROSTAR JUNIOR	ZQE	80	2500	338.1	338.1	20.6

MECHANICAL DATA

ZQE (S-PBGA-N80)

PLASTIC BALL GRID ARRAY

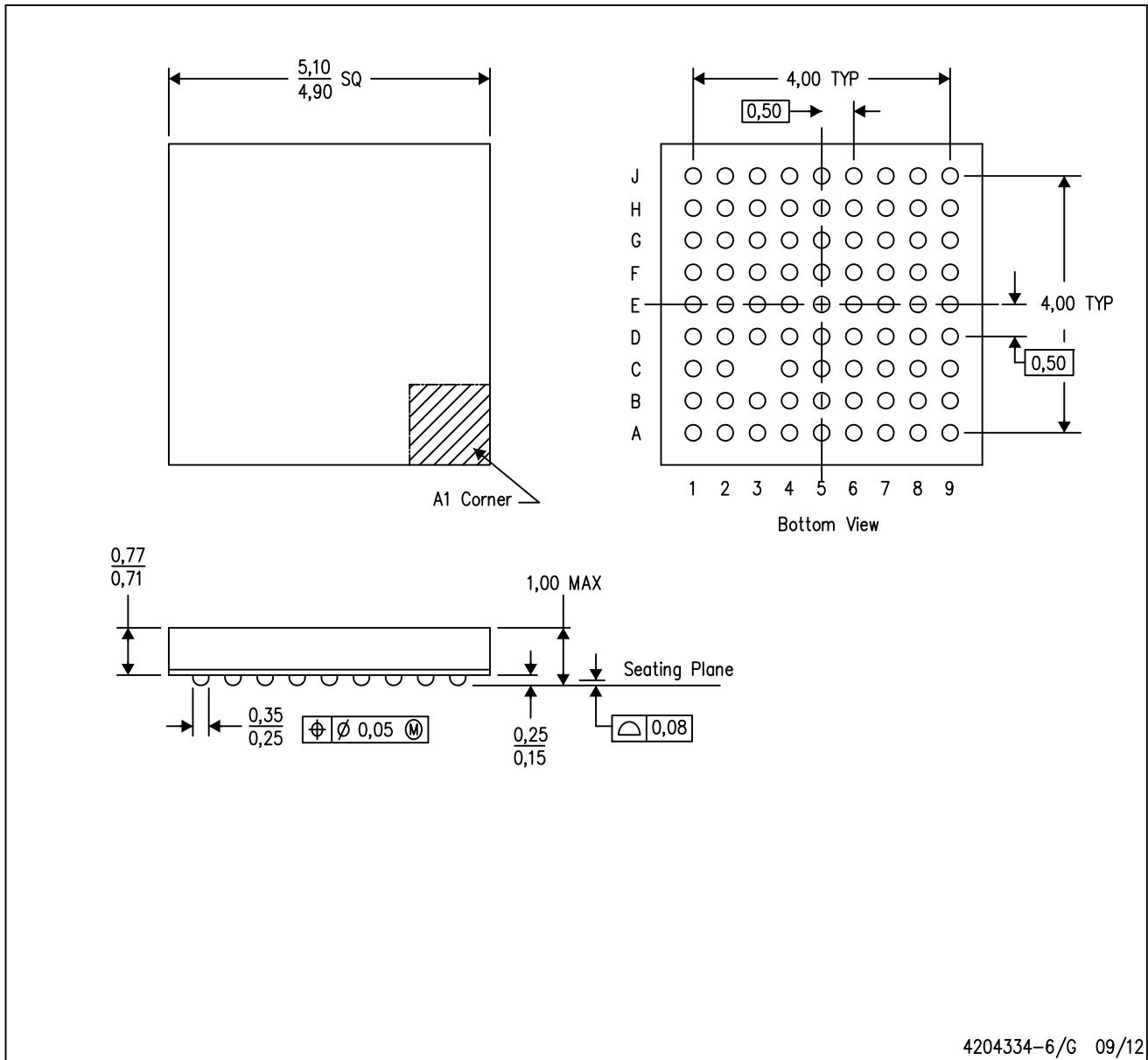

- NOTES:
- All linear dimensions are in millimeters. Dimensioning and tolerancing per ASME Y14.5M-1994.
 - This drawing is subject to change without notice.
 - Falls within JEDEC MO-225
 - This is a Pb-free solder ball design.

MicroStar Junior is a trademark of Texas Instruments.

MECHANICAL DATA

RGC(S-PVQFN-N64) CUSTOM DEVICE PLASTIC QUAD FLATPACK NO-LEAD

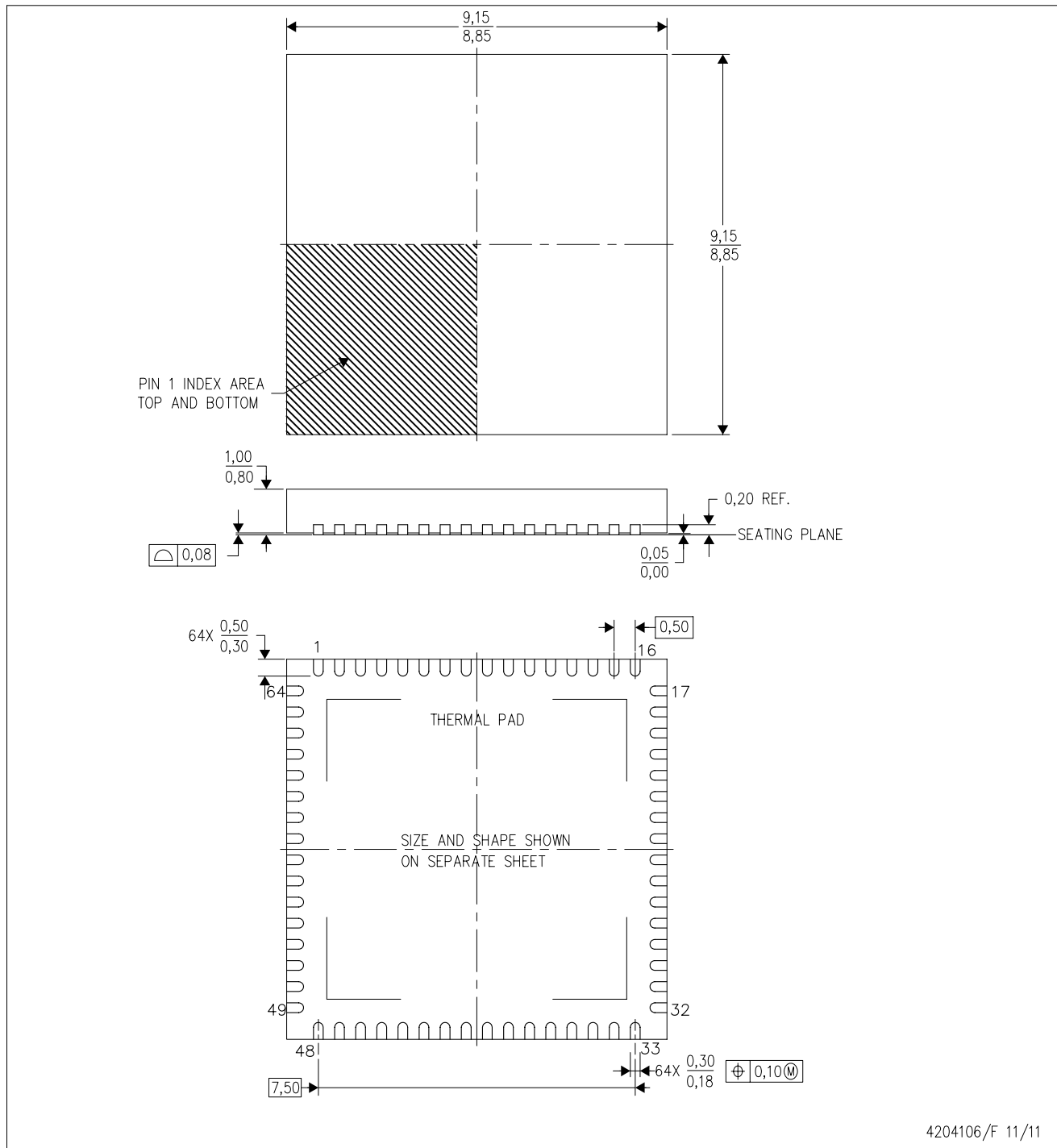

- NOTES:
- All linear dimensions are in millimeters. Dimensioning and tolerancing per ASME Y14.5-1994.
 - This drawing is subject to change without notice.
 - Quad Flatpack, No-leads (QFN) package configuration.
 - The package thermal pad must be soldered to the board for thermal and mechanical performance.
 - See the additional figure in the Product Data Sheet for details regarding the exposed thermal pad features and dimensions.

THERMAL PAD MECHANICAL DATA

RGC (S-PVQFN-N64)

PLASTIC QUAD FLATPACK NO-LEAD

THERMAL INFORMATION

This package incorporates an exposed thermal pad that is designed to be attached directly to an external heatsink. The thermal pad must be soldered directly to the printed circuit board (PCB). After soldering, the PCB can be used as a heatsink. In addition, through the use of thermal vias, the thermal pad can be attached directly to the appropriate copper plane shown in the electrical schematic for the device, or alternatively, can be attached to a special heatsink structure designed into the PCB. This design optimizes the heat transfer from the integrated circuit (IC).

For information on the Quad Flatpack No-Lead (QFN) package and its advantages, refer to Application Report, QFN/SON PCB Attachment, Texas Instruments Literature No. SLUA271. This document is available at www.ti.com.

The exposed thermal pad dimensions for this package are shown in the following illustration.

PIN 1 INDICATOR
CO,30

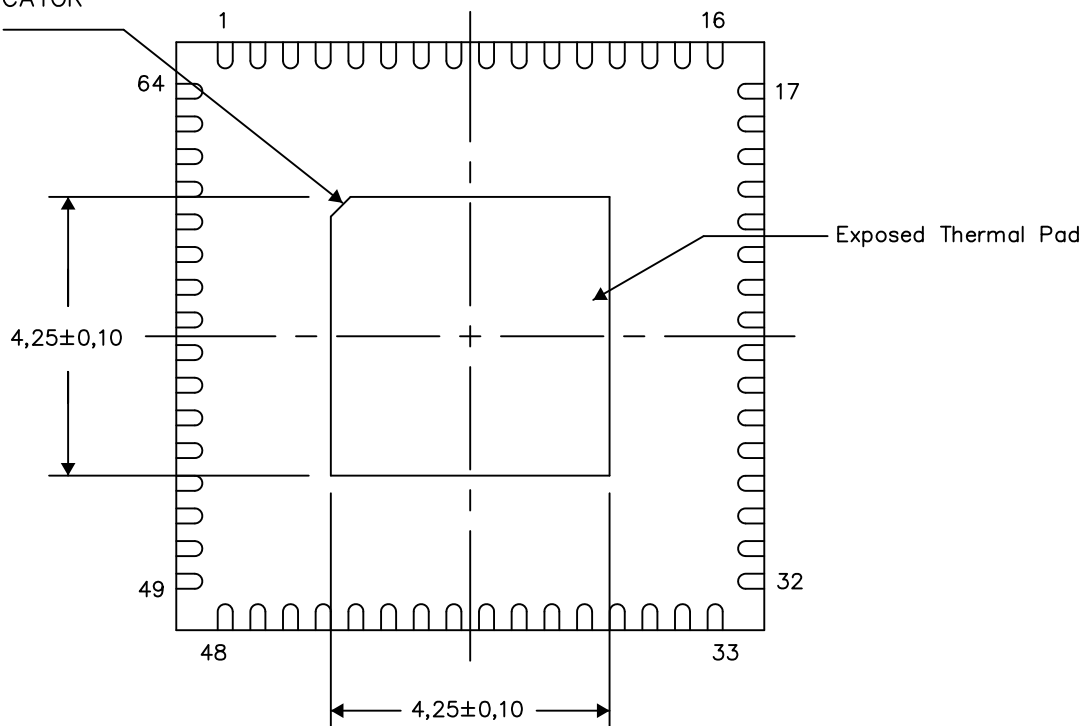

4206192-3/AE 03/15

NOTE: A. All linear dimensions are in millimeters

RGC (S-PVQFN-N64)

PLASTIC QUAD FLATPACK NO-LEAD

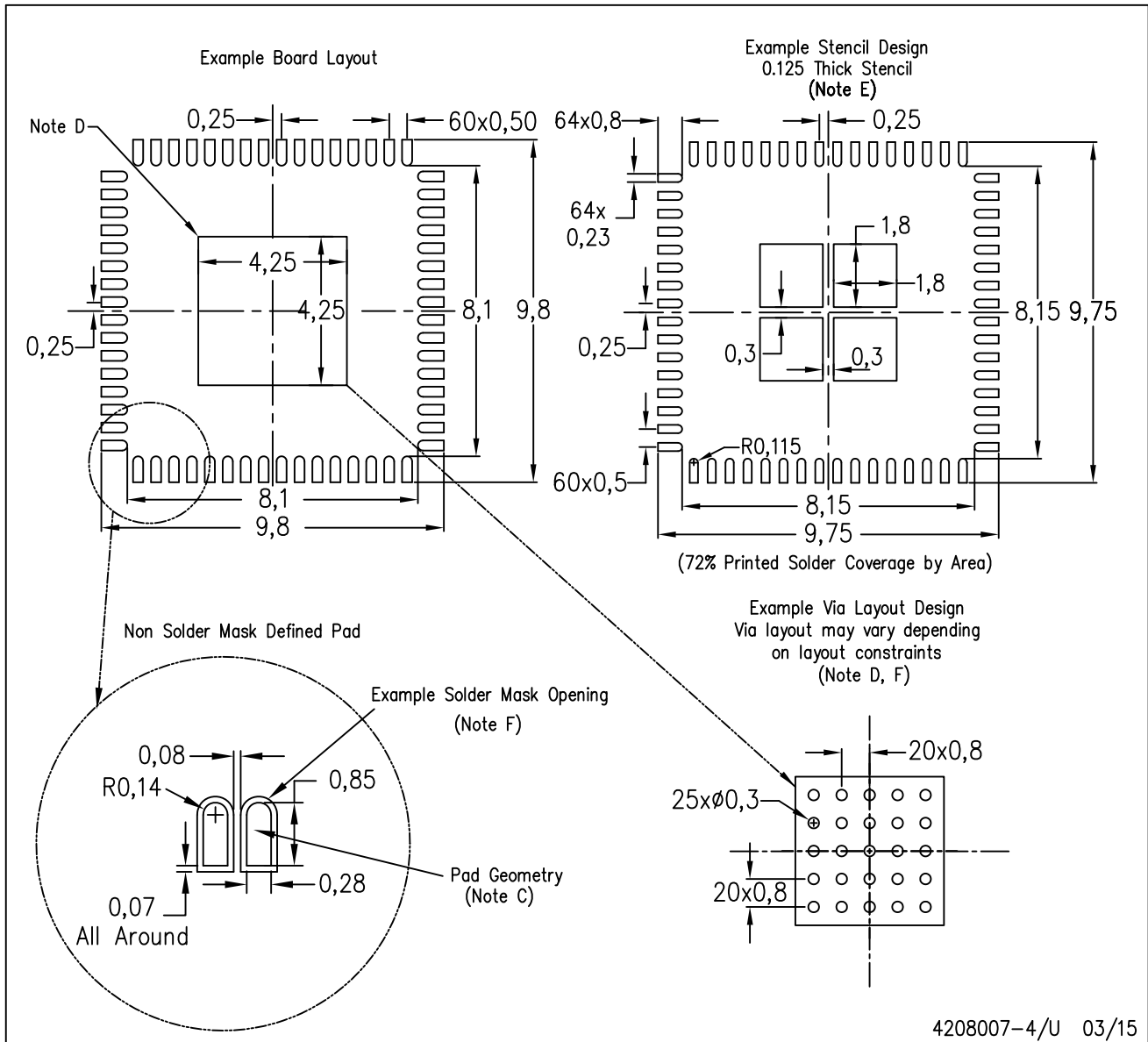

- NOTES:
- All linear dimensions are in millimeters.
 - This drawing is subject to change without notice.
 - Publication IPC-7351 is recommended for alternate designs.
 - This package is designed to be soldered to a thermal pad on the board. Refer to Application Note, Quad Flat-Pack Packages, Texas Instruments Literature No. SLUA271, and also the Product Data Sheets for specific thermal information, via requirements, and recommended board layout. These documents are available at www.ti.com <<http://www.ti.com>>.
 - Laser cutting apertures with trapezoidal walls and also rounding corners will offer better paste release. Customers should contact their board assembly site for stencil design recommendations. Refer to IPC 7525 for stencil design considerations.
 - Customers should contact their board fabrication site for recommended solder mask tolerances and via tenting recommendations for vias placed in thermal pad.

IMPORTANT NOTICE

Texas Instruments Incorporated and its subsidiaries (TI) reserve the right to make corrections, enhancements, improvements and other changes to its semiconductor products and services per JESD46, latest issue, and to discontinue any product or service per JESD48, latest issue. Buyers should obtain the latest relevant information before placing orders and should verify that such information is current and complete. All semiconductor products (also referred to herein as "components") are sold subject to TI's terms and conditions of sale supplied at the time of order acknowledgment.

TI warrants performance of its components to the specifications applicable at the time of sale, in accordance with the warranty in TI's terms and conditions of sale of semiconductor products. Testing and other quality control techniques are used to the extent TI deems necessary to support this warranty. Except where mandated by applicable law, testing of all parameters of each component is not necessarily performed.

TI assumes no liability for applications assistance or the design of Buyers' products. Buyers are responsible for their products and applications using TI components. To minimize the risks associated with Buyers' products and applications, Buyers should provide adequate design and operating safeguards.

TI does not warrant or represent that any license, either express or implied, is granted under any patent right, copyright, mask work right, or other intellectual property right relating to any combination, machine, or process in which TI components or services are used. Information published by TI regarding third-party products or services does not constitute a license to use such products or services or a warranty or endorsement thereof. Use of such information may require a license from a third party under the patents or other intellectual property of the third party, or a license from TI under the patents or other intellectual property of TI.

Reproduction of significant portions of TI information in TI data books or data sheets is permissible only if reproduction is without alteration and is accompanied by all associated warranties, conditions, limitations, and notices. TI is not responsible or liable for such altered documentation. Information of third parties may be subject to additional restrictions.

Resale of TI components or services with statements different from or beyond the parameters stated by TI for that component or service voids all express and any implied warranties for the associated TI component or service and is an unfair and deceptive business practice. TI is not responsible or liable for any such statements.

Buyer acknowledges and agrees that it is solely responsible for compliance with all legal, regulatory and safety-related requirements concerning its products, and any use of TI components in its applications, notwithstanding any applications-related information or support that may be provided by TI. Buyer represents and agrees that it has all the necessary expertise to create and implement safeguards which anticipate dangerous consequences of failures, monitor failures and their consequences, lessen the likelihood of failures that might cause harm and take appropriate remedial actions. Buyer will fully indemnify TI and its representatives against any damages arising out of the use of any TI components in safety-critical applications.

In some cases, TI components may be promoted specifically to facilitate safety-related applications. With such components, TI's goal is to help enable customers to design and create their own end-product solutions that meet applicable functional safety standards and requirements. Nonetheless, such components are subject to these terms.

No TI components are authorized for use in FDA Class III (or similar life-critical medical equipment) unless authorized officers of the parties have executed a special agreement specifically governing such use.

Only those TI components which TI has specifically designated as military grade or "enhanced plastic" are designed and intended for use in military/aerospace applications or environments. Buyer acknowledges and agrees that any military or aerospace use of TI components which have **not** been so designated is solely at the Buyer's risk, and that Buyer is solely responsible for compliance with all legal and regulatory requirements in connection with such use.

TI has specifically designated certain components as meeting ISO/TS16949 requirements, mainly for automotive use. In any case of use of non-designated products, TI will not be responsible for any failure to meet ISO/TS16949.

Products

Audio	www.ti.com/audio
Amplifiers	amplifier.ti.com
Data Converters	dataconverter.ti.com
DLP® Products	www.dlp.com
DSP	dsp.ti.com
Clocks and Timers	www.ti.com/clocks
Interface	interface.ti.com
Logic	logic.ti.com
Power Mgmt	power.ti.com
Microcontrollers	microcontroller.ti.com
RFID	www.ti-rfid.com
OMAP Applications Processors	www.ti.com/omap
Wireless Connectivity	www.ti.com/wirelessconnectivity

Applications

Automotive and Transportation	www.ti.com/automotive
Communications and Telecom	www.ti.com/communications
Computers and Peripherals	www.ti.com/computers
Consumer Electronics	www.ti.com/consumer-apps
Energy and Lighting	www.ti.com/energy
Industrial	www.ti.com/industrial
Medical	www.ti.com/medical
Security	www.ti.com/security
Space, Avionics and Defense	www.ti.com/space-avionics-defense
Video and Imaging	www.ti.com/video

TI E2E Community

e2e.ti.com