

## MIXED SIGNAL MICROCONTROLLER

Check for Samples: [MSP430F2619S-HT](#)

### FEATURES

- Low Supply Voltage Range 1.8 V to 3.6 V
- Ultralow-Power Consumption
  - Active Mode: 365  $\mu$ A at 1 MHz, 2.2 V
  - Standby Mode (VLO): 0.5  $\mu$ A
  - Off Mode (RAM Retention): 0.1  $\mu$ A
- Wake-Up From Standby Mode in Less than 1  $\mu$ s
- 16-Bit RISC Architecture, 62.5-ns Instruction Cycle Time
- Three-Channel Internal DMA
- 12-Bit Analog-to-Digital (A/D) Converter With Internal Reference, Sample-and-Hold, and Autoscan Feature
- Dual 12-Bit Digital-to-Analog (D/A) Converters With Synchronization
- 16-Bit Timer\_A With Three Capture/Compare Registers
- 16-Bit Timer\_B With Seven Capture/Compare-With-Shadow Registers
- On-Chip Comparator
- Four Universal Serial Communication Interfaces (USCIs)
  - USCI\_A0 and USCI\_A1
    - Enhanced UART Supporting Auto-Baud-Rate Detection (LIN)
    - IrDA Encoder and Decoder
    - Synchronous SPI
  - USCI\_B0 and USCI\_B1
    - I<sup>2</sup>C™
    - Synchronous SPI
- Supply Voltage Supervisor/Monitor With Programmable Level Detection
- Brownout Detector
- Bootstrap Loader
- Serial Onboard Programming, No External Programming Voltage Needed Programmable Code Protection by Security Fuse
- MSP430F2619S  
120 kB + 256 B Flash Memory, 4 kB RAM
- Available in 64-Pin QFP and KDG Packages
- For Complete Module Descriptions, Refer to the *MSP430x2xx Family User's Guide* ([SLAU144](#))

### SUPPORTS EXTREME TEMPERATURE APPLICATIONS

- Controlled Baseline
- One Assembly/Test Site
- One Fabrication Site
- Extended Product Life Cycle
- Extended Product-Change Notification
- Product Traceability
- This device is qualified for 1000 hours of continuous operation at maximum rated temperature.
- Texas Instruments high temperature products utilize highly optimized silicon (die) solutions with design and process enhancements to maximize performance over extended temperatures.

### DESCRIPTION

The MSP430F2619S ultralow-power microcontroller features different sets of peripherals targeted for various applications. The architecture, combined with five low power modes, is optimized to achieve extended battery life in portable measurement applications. The device features a powerful 16-bit RISC CPU, 16-bit registers, and constant generators that attribute to maximum code efficiency. The digitally controlled oscillator (DCO) allows wake-up from low-power modes to active mode in less than 1  $\mu$ s.

The MSP430F2619S is a microcontroller configuration with two built-in 16-bit timers, a fast 12-bit A/D converter, a comparator, dual 12-bit D/A converters, four universal serial communication interface (USCI) modules, DMA, and up to 64 I/O pins.



Please be aware that an important notice concerning availability, standard warranty, and use in critical applications of Texas Instruments semiconductor products and disclaimers thereto appears at the end of this data sheet.

All trademarks are the property of their respective owners.

## DESCRIPTION (CONTINUED)

Typical applications include sensor systems that capture analog signals, convert them to digital values, and then process the data for display or for transmission to a host system. Stand-alone RF sensor front end is another area of application.

**Table 1. ORDERING INFORMATION<sup>(1)</sup>**

T <sub>A</sub>	PACKAGE	ORDERABLE PART NUMBER
–55°C to 150°C	QFP (PM)	MSP430F2619SPM
	KGD (known good die)	MSP430F2619SKGD1

(1) For the most current package and ordering information, see the Package Option Addendum at the end of this document, or see the TI Web site at [www.ti.com](http://www.ti.com).

## DEVELOPMENT TOOL SUPPORT

All MSP430 microcontrollers include an Embedded Emulation Module (EEM) allowing advanced debugging and programming through easy-to-use development tools. Recommended hardware options include:

- Debugging and Programming Interface
  - MSP-FET430UIF (USB)
  - MSP-FET430PIF (Parallel Port)
- Debugging and Programming Interface with Target Board
  - MSP-FET430U64
  - MSP-FET430U80
- Standalone Target Board
  - MSP-TS430PM64
- Production Programmer
  - MSP-GANG430

PINOUT

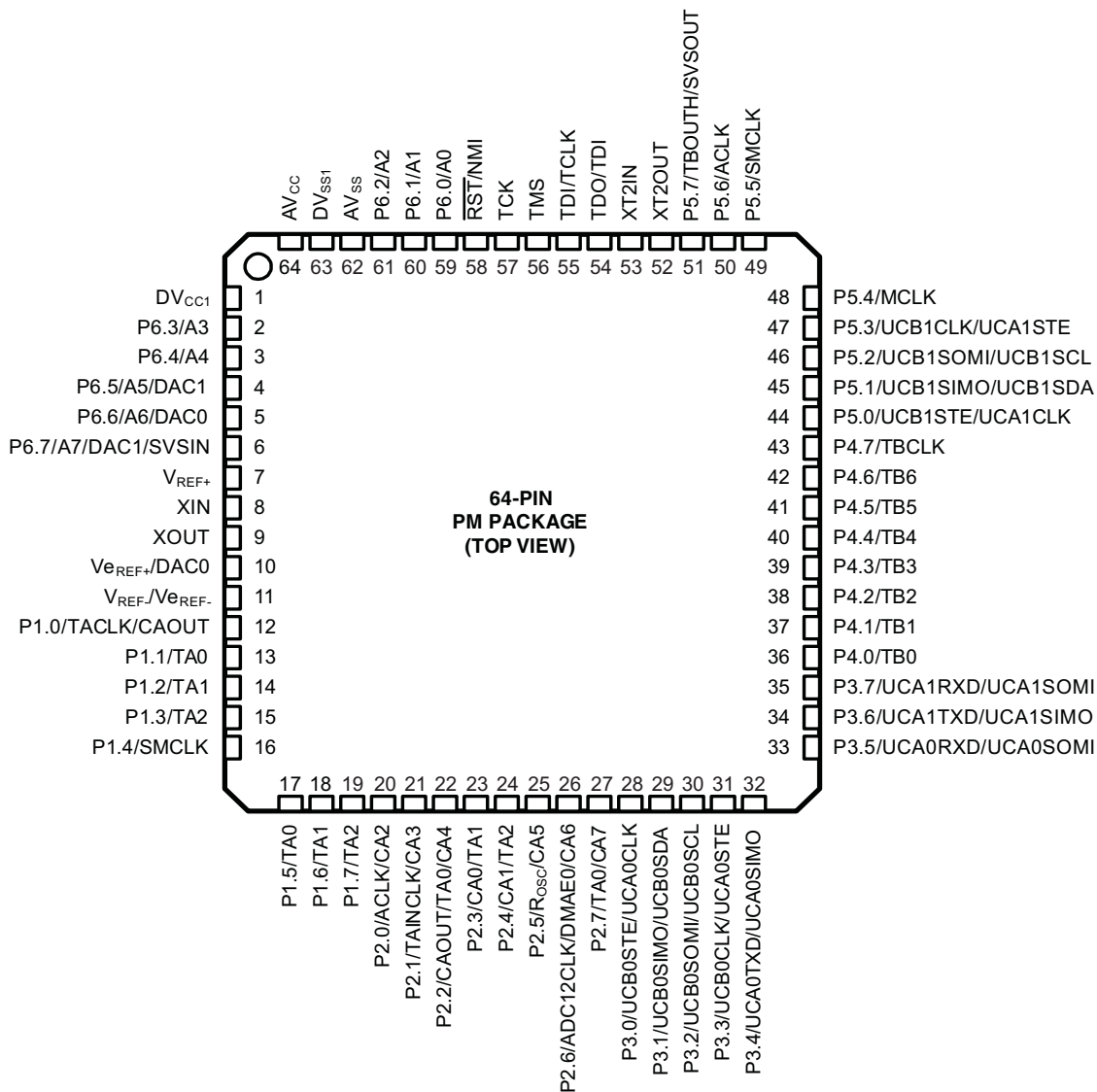

**TERMINAL FUNCTIONS (64-PM PACKAGE)**

TERMINAL		I/O	DESCRIPTION
NAME	PM		
AV <sub>CC</sub>	64		Analog supply voltage, positive terminal. Supplies only the analog portion of ADC12 and DAC12.
AV <sub>SS</sub>	62		Analog supply voltage, negative terminal. Supplies only the analog portion of ADC12 and DAC12.
DV <sub>CC1</sub>	1		Digital supply voltage, positive terminal. Supplies all digital parts.
DV <sub>SS1</sub>	63		Digital supply voltage, negative terminal. Supplies all digital parts.
P1.0/TACLK/CAOUT	12	I/O	General-purpose digital I/O pin/Timer_A, clock signal TACLK input/Comparator_A output
P1.1/TA0	13	I/O	General-purpose digital I/O pin/Timer_A, capture: CCI0A input, compare: Out0 output/BSL transmit
P1.2/TA1	14	I/O	General-purpose digital I/O pin/Timer_A, capture: CCI1A input, compare: Out1 output
P1.3/TA2	15	I/O	General-purpose digital I/O pin/Timer_A, capture: CCI2A input, compare: Out2 output
P1.4/SMCLK	16	I/O	General-purpose digital I/O pin/SMCLK signal output
P1.5/TA0	17	I/O	General-purpose digital I/O pin/Timer_A, compare: Out0 output
P1.6/TA1	18	I/O	General-purpose digital I/O pin/Timer_A, compare: Out1 output
P1.7/TA2	19	I/O	General-purpose digital I/O pin/Timer_A, compare: Out2 output
P2.0/ACLK/CA2	20	I/O	General-purpose digital I/O pin/ACLK output/Comparator_A input
P2.1/TAINCLK/CA3	21	I/O	General-purpose digital I/O pin/Timer_A, clock signal at INCLK
P2.2/CAOUT/TA0/CA4	22	I/O	General-purpose digital I/O pin/Timer_A, capture: CCI0B input/Comparator_A output/BSL receive/Comparator_A input
P2.3/CA0/TA1	23	I/O	General-purpose digital I/O pin/Timer_A, compare: Out1 output/Comparator_A input
P2.4/CA1/TA2	24	I/O	General-purpose digital I/O pin/Timer_A, compare: Out2 output/Comparator_A input
P2.5/Rosc/CA5	25	I/O	General-purpose digital I/O pin/input for external resistor defining the DCO nominal frequency/Comparator_A input
P2.6/ADC12CLK/DMAE0/CA6	26	I/O	General-purpose digital I/O pin/conversion clock – 12-bit ADC/DMA channel 0 external trigger/Comparator_A input
P2.7/TA0/CA7	27	I/O	General-purpose digital I/O pin/Timer_A, compare: Out0 output/Comparator_A input
P3.0/UCB0STE/UCA0CLK	28	I/O	General-purpose digital I/O pin/USCI B0 slave transmit enable/USCI A0 clock input/output
P3.1/UCB0SIMO/UCB0SDA	29	I/O	General-purpose digital I/O pin/USCI B0 slave in/master out in SPI mode, SDA I <sup>2</sup> C data in I <sup>2</sup> C mode
P3.2/UCB0SOMI/UCB0SCL	30	I/O	General-purpose digital I/O pin/USCI B0 slave out/master in in SPI mode, SCL I <sup>2</sup> C clock in I <sup>2</sup> C mode
P3.3/UCB0CLK/UCA0STE	31	I/O	General-purpose digital I/O/USCI B0 clock input/output, USCI A0 slave transmit enable
P3.4/UCA0TXD/UCA0SIMO	32	I/O	General-purpose digital I/O pin/USCIA transmit data output in UART mode, slave data in/master out in SPI mode
P3.5/UCA0RXD/UCA0SOMI	33	I/O	General-purpose digital I/O pin/USCI A0 receive data input in UART mode, slave data out/master in in SPI mode
P3.6/UCA1TXD/UCA1SIMO	34	I/O	General-purpose digital I/O pin/USCI A1 transmit data output in UART mode, slave data in/master out in SPI mode
P3.7/UCA1RXD/UCA1SOMI	35	I/O	General-purpose digital I/O pin/USCIA1 receive data input in UART mode, slave data out/master in in SPI mode
P4.0/TB0	36	I/O	General-purpose digital I/O pin/Timer_B, capture: CCI0A/B input, compare: Out0 output
P4.1/TB1	37	I/O	General-purpose digital I/O pin/Timer_B, capture: CCI1A/B input, compare: Out1 output
P4.2/TB2	38	I/O	General-purpose digital I/O pin/Timer_B, capture: CCI2A/B input, compare: Out2 output

**TERMINAL FUNCTIONS (64-PM PACKAGE) (continued)**

TERMINAL		I/O	DESCRIPTION
NAME	PM		
P4.3/TB3	39	I/O	General-purpose digital I/O pin/Timer_B, capture: CCI3A/B input, compare: Out3 output
P4.4/TB4	40	I/O	General-purpose digital I/O pin/Timer_B, capture: CCI4A/B input, compare: Out4 output
P4.5/TB5	41	I/O	General-purpose digital I/O pin/Timer_B, capture: CCI5A/B input, compare: Out5 output
P4.6/TB6	42	I/O	General-purpose digital I/O pin/Timer_B, capture: CCI6A input, compare: Out6 output
P4.7/TBCLK	43	I/O	General-purpose digital I/O pin/Timer_B, clock signal TBCLK input
P5.0/UCB1STE/UCA1CLK	44	I/O	General-purpose digital I/O pin/USCI B1 slave transmit enable/USCI A1 clock input/output
P5.1/UCB1SIMO/UCB1SDA	45	I/O	General-purpose digital I/O pin/USCI B1slave in/master out in SPI mode, SDA I <sup>2</sup> C data in I <sup>2</sup> C mode
P5.2/UCB1SOMI/UCB1SCL	46	I/O	General-purpose digital I/O pin/USCI B1slave out/master in in SPI mode, SCL I <sup>2</sup> C clock in I <sup>2</sup> C mode
P5.3/UCB1CLK/UCA1STE	47	I/O	General-purpose digital I/O/USCI B1 clock input/output, USCI A1 slave transmit enable
P5.4/MCLK	48	I/O	General-purpose digital I/O pin/main system clock MCLK output
P5.5/SMCLK	49	I/O	General-purpose digital I/O pin/submain system clock SMCLK output
P5.6/ACLK	50	I/O	General-purpose digital I/O pin/auxiliary clock ACLK output
P5.7/TBOUTH/SVSOUT	51	I/O	General-purpose digital I/O pin/switch all PWM digital output ports to high impedance -- Timer_B TB0 to TB6/SVS comparator output
P6.0/A0	59	I/O	General-purpose digital I/O pin/analog input A0 – 12-bit ADC
P6.1/A1	60	I/O	General-purpose digital I/O pin/analog input A1 – 12-bit ADC
P6.2/A2	61	I/O	General-purpose digital I/O pin/analog input A2 – 12-bit ADC
P6.3/A3	2	I/O	General-purpose digital I/O pin/analog input A3 – 12-bit ADC
P6.4/A4	3	I/O	General-purpose digital I/O pin/analog input A4 – 12-bit ADC
P6.5/A5/DAC1	4	I/O	General-purpose digital I/O pin/analog input A5 – 12-bit ADC/DAC12.1 output
P6.6/A6/DAC0	5	I/O	General-purpose digital I/O pin/analog input A6 – 12-bit ADC/DAC12.0 output
P6.7/A7/DAC1/SVSIN	6	I/O	General-purpose digital I/O pin/analog input a7 – 12-bit ADC/DAC12.1 output/SVS input
P7.0	NC	I/O	General-purpose digital I/O pin
P7.1	NC	I/O	General-purpose digital I/O pin
P7.2	NC	I/O	General-purpose digital I/O pin
P7.3	NC	I/O	General-purpose digital I/O pin
P7.4	NC	I/O	General-purpose digital I/O pin
P7.5	NC	I/O	General-purpose digital I/O pin
P7.6	NC	I/O	General-purpose digital I/O pin
P7.7	NC	I/O	General-purpose digital I/O pin
P8.0	NC	I/O	General-purpose digital I/O pin
P8.1	NC	I/O	General-purpose digital I/O pin
P8.2	NC	I/O	General-purpose digital I/O pin
P8.3	NC	I/O	General-purpose digital I/O pin
P8.4	NC	I/O	General-purpose digital I/O pin
P8.5	NC	I/O	General-purpose digital I/O pin
P8.6/XT2OUT	NC	O	General-purpose digital I/O pin/Output terminal of crystal oscillator XT2
P8.7/XT2IN	NC	I	General-purpose digital I/O pin/Input port for crystal oscillator XT2. Only standard crystals can be connected.

**TERMINAL FUNCTIONS (64-PM PACKAGE) (continued)**

TERMINAL		I/O	DESCRIPTION
NAME	PM		
XT2OUT	52	O	Output terminal of crystal oscillator XT2
XT2IN	53	I	Input port for crystal oscillator XT2
$\overline{\text{RST}}/\text{NMI}$	58	I	Reset input, nonmaskable interrupt input port, or bootstrap loader start (in flash devices)
TCK	57	I	Test clock (JTAG). TCK is the clock input port for device programming test and bootstrap loader start.
TDI/TCLK	55	I	Test data input or test clock input. The device protection fuse is connected to TDI/TCLK.
TDO/TDI	54	I/O	Test data output port. TDO/TDI data output or programming data input terminal.
TMS	56	I	Test mode select. TMS is used as an input port for device programming and test.
$V_{\text{REF+}}/\text{DAC0}$	10	I	Input for an external reference voltage/DAC12.0 output
$V_{\text{REF+}}$	7	O	Output of positive terminal of the reference voltage in the ADC12
$V_{\text{REF-}}/V_{\text{REF-}}$	11	I	Negative terminal for the reference voltage for both sources, the internal reference voltage, or an external applied reference voltage
XIN	8	I	Input port for crystal oscillator XT1. Standard or watch crystals can be connected.
XOUT	9	O	Output port for crystal oscillator XT1. Standard or watch crystals can be connected.

**BARE DIE INFORMATION**

DIE THICKNESS	BACKSIDE FINISH	BACKSIDE POTENTIAL	BOND PAD METALLIZATION COMPOSITION	BOND PAD THICKNESS
10.5 mils.	Silicon with backgrind	Floating	TiN/AlCu.5%	800 nm

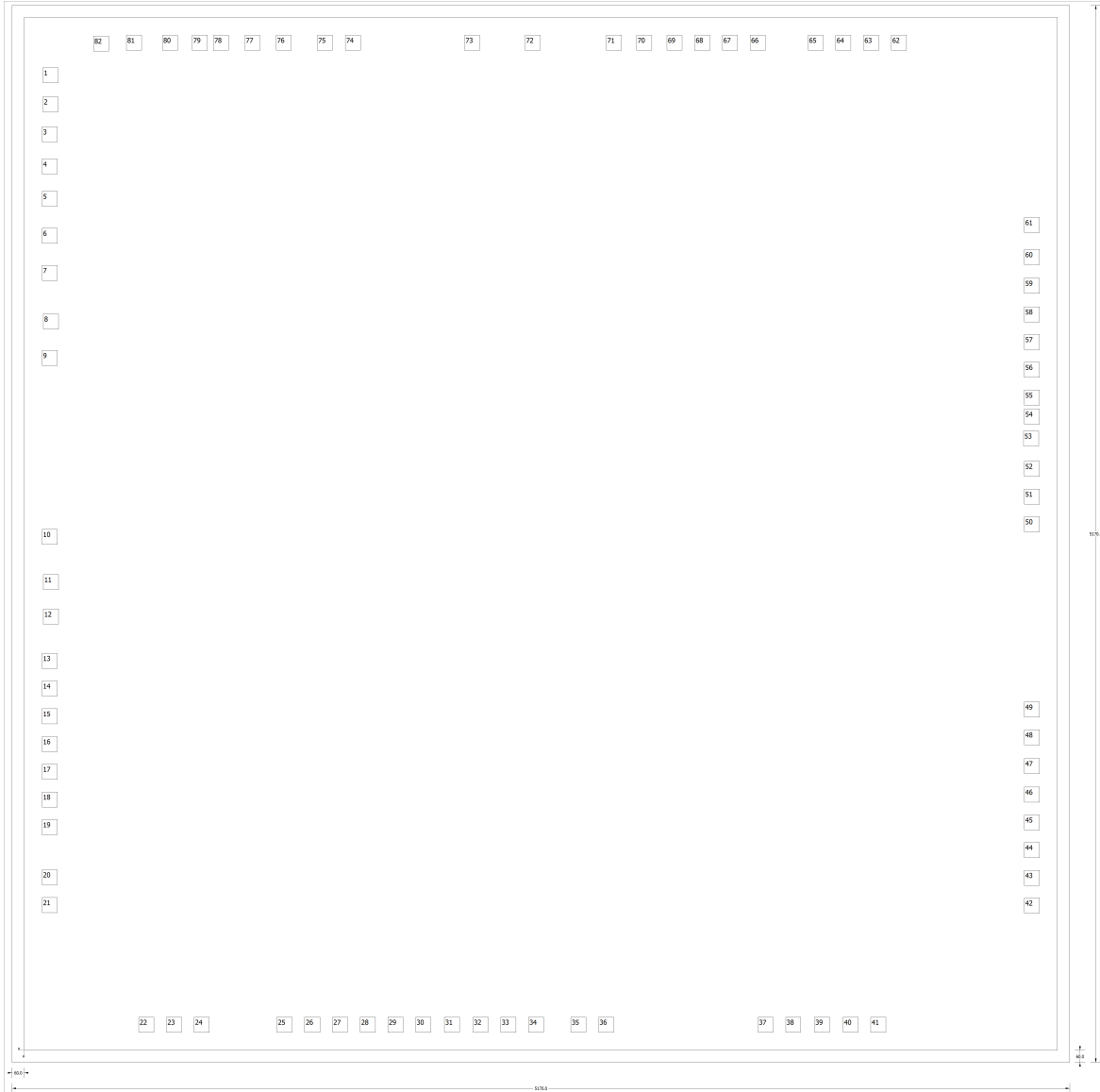

**Table 2. Bond Pad Coordinates in Microns**

DESCRIPTION	PAD NUMBER	X MIN	Y MIN	X MAX	Y MAX
AVCC	1	90.65	4729.1	165.65	4804.1
DVCC1	2	90.65	4586.85	165.65	4661.85
P6.3/A3	3	87.4	4440.3	162.4	4515.3
P6.4/A4	4	87.4	4282.65	162.4	4357.65
P6.5/A5/DAC1	5	87.4	4125.05	162.4	4200.05
P6.6/A6/DAC0	6	87.4	3943.9	162.4	4018.9
P6.7/A7/DAC1/SVSIN	7	87.4	3762.75	162.4	3837.75
VREF+	8	92.95	3524.75	167.95	3599.75
XIN	9	87.4	3346.6	162.4	3421.6
XOUT	10	87.4	2472.4	162.4	2547.4
VeREF+/DAC0	11	92.95	2251	167.95	2326
VREF-/VeREF-	12	92.95	2082.5	167.95	2157.5
P1.0/TACLK/CAOUT	13	87.4	1866.2	162.4	1941.2
N/C	14	87.4	1730.6	162.4	1805.6
N/C	15	87.4	1595	162.4	1670
N/C	16	87.4	1459.4	162.4	1534.4
N/C	17	87.4	1323.8	162.4	1398.8
P1.1/TA0	18	87.4	1188.2	162.4	1263.2
P1.2/TA1	19	87.4	1052.6	162.4	1127.6
P1.3/TA2	20	87.4	807.7	162.4	882.7
P1.4/SMCLK	21	87.4	672.1	162.4	747.1
P1.5/TA0	22	559.1	87.4	634.1	162.4
P1.6/TA1	23	694.7	87.4	769.7	162.4
P1.7/TA2	24	830.3	87.4	905.3	162.4
P2.0/ACLK/CA2	25	1234.9	87.4	1309.9	162.4
P2.1/TAINCLK/CA3	26	1370.5	87.4	1445.5	162.4
P2.2/CAOUT/TA0/CA4	27	1506.1	87.4	1581.1	162.4
N/C	28	1641.7	87.4	1716.7	162.4
N/C	29	1777.3	87.4	1852.3	162.4
N/C	30	1912.9	87.4	1987.9	162.4
N/C	31	2053	87.4	2128	162.4
P2.3/CA0/TA1	32	2193.1	87.4	2268.1	162.4
P2.4/CA1/TA2	33	2328.7	87.4	2403.7	162.4
P2.5/ROSC/CA5	34	2464.3	87.4	2539.3	162.4
P2.6/ADC12CLK/DMAE0/CA6	35	2671.1	87.4	2746.1	162.4
P2.7/TA0/CA7	36	2807.15	87.4	2882.15	162.4
P3.0/UCB0STE/UCA0CLK	37	3585.9	87.4	3660.9	162.4
P3.1/UCB0SIMO/UCB0SDA	38	3721.5	87.4	3796.5	162.4
P3.2/UCB0SOMI/UCB0SCL	39	3861.6	87.4	3936.6	162.4
P3.3/UCB0CLK/UCA0STE	40	4001.7	87.4	4076.7	162.4
P3.4/UCA0TXD/UCA0SIMO	41	4137.3	87.4	4212.3	162.4
P3.5/UCA0RXD/UCA0SOMI	42	4887.6	669.65	4962.6	744.65
P3.6/UCA1TXD/UCA1SIMO	43	4887.6	805.25	4962.6	880.25
P3.7/UCA1RXD/UCA1SOMI	44	4887.6	940.85	4962.6	1015.85
N/C	45	4887.6	1076.45	4962.6	1151.45
N/C	46	4887.6	1212.05	4962.6	1287.05
P4.0/TB0	47	4887.6	1352.15	4962.6	1427.15

**Table 2. Bond Pad Coordinates in Microns (continued)**

DESCRIPTION	PAD NUMBER	X MIN	Y MIN	X MAX	Y MAX
P4.1/TB1	48	4887.6	1492.25	4962.6	1567.25
P4.2/TB2	49	4887.6	1627.85	4962.6	1702.85
P4.3/TB3	50	4887.6	2533.55	4962.6	2608.55
P4.4/TB4	51	4887.6	2669.15	4962.6	2744.15
P4.5/TB5	52	4887.6	2804.75	4962.6	2879.75
N/C	53	4884.35	2953.25	4959.35	3028.25
N/C	54	4887.6	3060.45	4962.6	3135.45
P4.6/TB6	55	4887.6	3153.45	4962.6	3228.45
P4.7/TBCLK	56	4887.6	3289.05	4962.6	3364.05
P5.0/UCB1STE/UCA1CLK	57	4887.6	3424.65	4962.6	3499.65
P5.1/UCB1SIMO/UCB1SDA	58	4887.6	3560.25	4962.6	3635.25
P5.2/UCB1SOMI/UCB1SCL	59	4887.6	3700.35	4962.6	3775.35
P5.3/UCB1CLK/UCA1STE	60	4887.6	3840.45	4962.6	3915.45
P5.4/MCLK	61	4887.6	3997.05	4962.6	4072.05
P5.5/SMCLK	62	4237.65	4887.6	4312.65	4962.6
P5.6/ACLK	63	4102.05	4887.6	4177.05	4962.6
P5.7/TBOUTH/SVSOUT	64	3966.45	4887.6	4041.45	4962.6
N/C	65	3830.85	4887.6	3905.85	4962.6
N/C	66	3547.7	4887.6	3622.7	4962.6
N/C	67	3412.1	4887.6	3487.1	4962.6
N/C	68	3276.5	4887.6	3351.5	4962.6
XT2OUT	69	3140.9	4887.6	3215.9	4962.6
XT2IN	70	2992.85	4887.6	3067.85	4962.6
TDO/TDI	71	2844.6	4887.6	2919.6	4962.6
TDI/TCLK	72	2448	4887.6	2523	4962.6
TMS	73	2152.25	4887.6	2227.25	4962.6
TCK	74	1568.55	4887.6	1643.55	4962.6
RST/NMI	75	1431.85	4887.6	1506.85	4962.6
P6.0/A0	76	1230.75	4887.6	1305.75	4962.6
P6.1/A1	77	1077.9	4887.6	1152.9	4962.6
P6.2/A2	78	923.95	4887.6	998.95	4962.6
AVSS	79	821.05	4887.95	896.05	4962.95
AVSS	80	674.95	4887.6	749.95	4962.6
DVSS1	81	499.2	4887.6	574.2	4962.6
AVCC	82	337.85	4884.35	412.85	4959.35

**FUNCTIONAL BLOCK DIAGRAM**

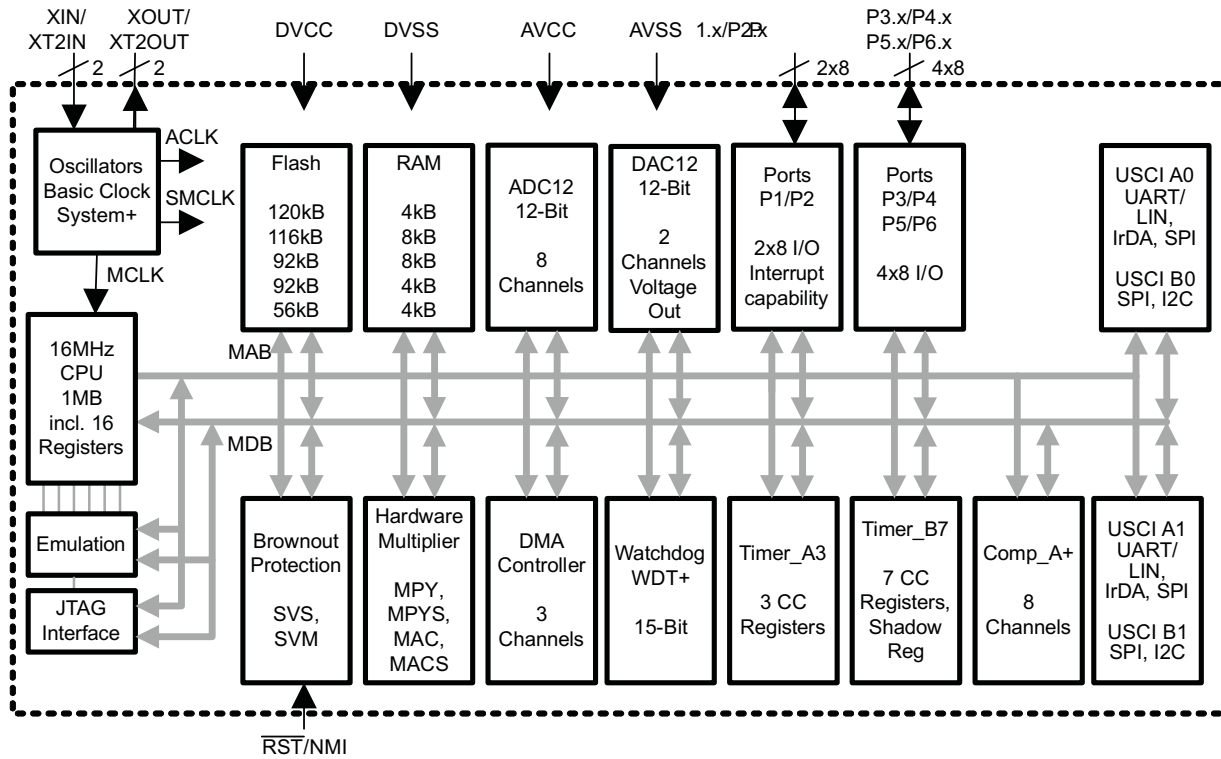

## SHORT-FORM DESCRIPTION

### CPU

The MSP430 CPU has a 16-bit RISC architecture that is highly transparent to the application. All operations, other than program-flow instructions, are performed as register operations in conjunction with seven addressing modes for source operand and four addressing modes for destination operand.

The CPU is integrated with 16 registers that provide reduced instruction execution time. The register-to-register operation execution time is one cycle of the CPU clock.

Four of the registers, R0 to R3, are dedicated as program counter, stack pointer, status register, and constant generator respectively. The remaining registers are general-purpose registers.

Peripherals are connected to the CPU using data, address, and control buses, and can be handled with all instructions.

### Instruction Set

The instruction set consists of 51 instructions with three formats and seven address modes. Each instruction can operate on word and byte data. [Table 3](#) shows examples of the three types of instruction formats; the address modes are listed in [Table 4](#).

Program Counter	PC/R0
Stack Pointer	SP/R1
Status Register	SR/CG1/R2
Constant Generator	CG2/R3
General-Purpose Register	R4
General-Purpose Register	R5
General-Purpose Register	R6
General-Purpose Register	R7
General-Purpose Register	R8
General-Purpose Register	R9
General-Purpose Register	R10
General-Purpose Register	R11
General-Purpose Register	R12
General-Purpose Register	R13
General-Purpose Register	R14
General-Purpose Register	R15

**Table 3. Instruction Word Formats**

Dual operands, source-destination	e.g., ADD R4,R5	R4 + R5 → R5
Single operands, destination only	e.g., CALL R8	PC → (TOS), R8 → PC
Relative jump, un/conditional	e.g., JNE	Jump-on-equal bit = 0

**Table 4. Address Mode Descriptions**

ADDRESS MODE	S <sup>(1)</sup>	D <sup>(2)</sup>	SYNTAX	EXAMPLE	OPERATION
Register	•	•	MOV Rs,Rd	MOV R10,R11	R10 → R11
Indexed	•	•	MOV X(Rn),Y(Rm)	MOV 2(R5),6(R6)	M(2+R5) → M(6+R6)
Symbolic (PC relative)	•	•	MOV EDE,TONI		M(EDE) → M(TONI)
Absolute	•	•	MOV &MEM,&TCDAT		M(MEM) → M(TCDAT)
Indirect	•		MOV @Rn,Y(Rm)	MOV @R10,Tab(R6)	M(R10) → M(Tab+R6)
Indirect autoincrement	•		MOV @Rn+,Rm	MOV @R10+,R11	M(R10) → R11 R10 + 2 → R10
Immediate	•		MOV #X,TONI	MOV #45,TONI	#45 → M(TONI)

(1) S = source

(2) D = destination

## Operating Modes

The MSP430 has one active mode and five software selectable low-power modes of operation. An interrupt event can wake up the device from any of the five low-power modes, service the request and restore back to the low-power mode on return from the interrupt program.

The following six operating modes can be configured by software:

- Active mode ( AM)
  - All clocks are active.
- Low-power mode 0 (LPM0)
  - CPU is disabled.
  - ACLK and SMCLK remain active. MCLK is disabled.
- Low-power mode 1 (LPM1)
  - CPU is disabled.
  - ACLK and SMCLK remain active. MCLK is disabled.
  - DCO's dc generator is disabled if DCO not used in active mode.
- Low-power mode 2 (LPM2)
  - CPU is disabled.
  - MCLK and SMCLK are disabled.
  - DCO's dc-generator remains enabled.
  - ACLK remains active
- Low-power mode 3 (LPM3)
  - CPU is disabled.
  - MCLK and SMCLK are disabled.
  - DCO's dc-generator is disabled.
  - ACLK remains active.
- Low-power mode 4 (LPM4)
  - CPU is disabled.
  - ACLK is disabled.
  - MCLK and SMCLK are disabled.
  - DCO's dc-generator is disabled.
  - Crystal oscillator is stopped.

## Interrupt Vector Addresses

The interrupt vectors and the power-up starting address are located in the address range of 0FFFF–0FFC0h. The vector contains the 16-bit address of the appropriate interrupt handler instruction sequence.

If the reset vector (located at address 0FFFEh) contains 0FFFFh (e.g., flash is not programmed), the CPU goes into LPM4 immediately after power up.

INTERRUPT SOURCE	INTERRUPT FLAG	SYSTEM INTERRUPT	WORD ADDRESS	PRIORITY
Power up External reset Watchdog Flash key violation PC out-of-range <sup>(1)</sup>	PORIFG RSTIFG WDTIFG KEYV <sup>(2)</sup>	Reset	0x0FFFE	31, highest
NMI Oscillator fault Flash memory access violation	NMIIFG OFIFG ACCVIFG <sup>(2) (3)</sup>	(non)-maskable, (non)-maskable, (non)-maskable	0x0FFFC	30
Timer_B7	TBCCR0 CCIFG <sup>(4)</sup>	maskable	0x0FFFA	29
Timer_B7	TBCCR1 and TBCCR2 CCIFGs, TBIFG <sup>(2) (4)</sup>	maskable	0x0FFF8	28
Comparator_A+	CAIFG	maskable	0x0FFF6	27
Watchdog timer+	WDTIFG	maskable	0x0FFF4	26
Timer_A3	TACCR0 CCIFG <sup>(4)</sup>	maskable	0x0FFF2	25
Timer_A3	TACCR1 CCIFG, TACCR2 CCIFG, TAIFG <sup>(2) (4)</sup>	maskable	0x0FFF0	24
USCI_A0/USCI_B0 receive USCI_B0 I2C status	UCA0RXIFG, UCB0RXIFG <sup>(2) (5)</sup>	maskable	0x0FFEE	23
USCI_A0/USCI_B0 transmit USCI_B0 I2C receive/transmit	UCA0TXIFG, UCB0TXIFG <sup>(2) (6)</sup>	maskable	0x0FFEC	22
ADC12	ADC12IFG <sup>(4)</sup>	maskable	0x0FFEA	21
			0x0FFE8	20
I/O port P2 (eight flags)	P2IFG.0 to P2IFG.7 <sup>(2) (4)</sup>	maskable	0x0FFE6	19
I/O port P1 (eight flags)	P1IFG.0 to P1IFG.7 <sup>(2) (4)</sup>	maskable	0x0FFE4	18
USCI_A0/USCI_B1 receive USCI_B1 I2C status	UCA1RXIFG, UCB1RXIFG <sup>(2) (5)</sup>	maskable	0x0FFE2	17
USCI_A1/USCI_B1 transmit USCI_B1 I2C receive/transmit	UCA1TXIFG, UCB1TXIFG <sup>(2) (6)</sup>	maskable	0x0FFE0	16
DMA	DMA0IFG, DMA1IFG, DMA2IFG <sup>(2) (4)</sup>	maskable	0x0FFDE	15
DAC12	DAC12_0IFG, DAC12_1IFG <sup>(2)</sup> <sup>(4)</sup>	maskable	0x0FFDC	14
Reserved <sup>(7) (8)</sup>	Reserved		0x0FFDA to 0x0FFC0	13 to 0, lowest

- (1) A reset is generated if the CPU tries to fetch instructions from within the module register memory address range (0x00000 – 0x001FF) or from within unused address range.
- (2) Multiple source flags
- (3) (non)-maskable: the individual interrupt-enable bit can disable an interrupt event, but the general interrupt enable cannot.
- (4) Interrupt flags are located in the module.
- (5) In SPI mode: UCB0RXIFG. In I<sup>2</sup>C mode: UCALIFG, UCNACKIFG, ICSTTIFG, UCSTPIFG.
- (6) In UART/SPI mode: UCB0TXIFG. In I<sup>2</sup>C mode: UCB0RXIFG, UCB0TXIFG.
- (7) The address 0x0FFBE is used as bootstrap loader security key (BSLSKEY). A 0x0AA55 at this location disables the BSL completely. A zero disables the erasure of the flash if an invalid password is supplied.
- (8) The interrupt vectors at addresses 0x0FFDC to 0x0FFC0 are not used in this device and can be used for regular program code if necessary.

## Special Function Registers

Most interrupt and module enable bits are collected into the lowest address space. Special function register bits not allocated to a functional purpose are not physically present in the device. Simple software access is provided with this arrangement.

### Interrupt Enable 1 and 2

Address	7	6	5	4	3	2	1	0
00h			ACCVIE	NMIIE			OFIE	WDTIE
			rw-0	rw-0			rw-0	rw-0

WDTIE: Watchdog Timer interrupt enable. Inactive if watchdog mode is selected. Active if Watchdog Timer is configured in interval timer mode.

OFIE: Oscillator fault enable

NMIIE: (Non)maskable interrupt enable

ACCVIE: Flash access violation interrupt enable

Address	7	6	5	4	3	2	1	0
01h					UCB0TXIE	UCB0RXIE	UCA0TXIE	UCA0RXIE
					rw-0	rw-0	rw-0	rw-0

UCA0RXIE USCI\_A0 receive-interrupt enable

UCA0TXIE USCI\_A0 transmit-interrupt enable

UCB0RXIE USCI\_B0 receive-interrupt enable

UCB0TXIE USCI\_B0 transmit-interrupt enable

### Interrupt Flag Register 1 and 2

Address	7	6	5	4	3	2	1	0
02h				NMIIFG	RSTIFG	PORIFG	OFIFG	WDTIFG
				rw-0	rw-(0)	rw-(1)	rw-1	rw-(0)

WDTIFG: Set on Watchdog Timer overflow (in watchdog mode) or security key violation. Reset on  $V_{CC}$  power-up or a reset condition at  $\overline{RST}/NMI$  pin in reset mode.

OFIFG: Flag set on oscillator fault7

RSTIFG: External reset interrupt flag. Set on a reset condition at  $\overline{RST}/NMI$  pin in reset mode. Reset on  $V_{CC}$  power up.

PORIFG: Power-On Reset interrupt flag. Set on  $V_{CC}$  power up.

NMIIFG: Set via  $\overline{RST}/NMI$ -pin

Address	7	6	5	4	3	2	1	0
03h					UCB0TXIFG	UCB0RXIFG	UCA0TXIFG	UCA0RXIFG
					rw-1	rw-0	rw-1	rw-0

UCA0RXIFG USCI\_A0 receive-interrupt flag

UCA0TXIFG USCI\_A0 transmit-interrupt flag

UCB0RXIFG USCI\_B0 receive-interrupt flag

UCB0TXIFG USCI\_B0 transmit-interrupt flag

#### Legend:

rw: Bit can be read and written.

rw-0, 1: Bit can be read and written. It is Reset or Set by PUC.

rw-(0), (1): Bit can be read and written. It is Reset or Set by POR.



SFR bit is not present in device.

## Memory Organization

			<b>MSP430F2619</b>
Memory Main: interrupt vector Main: code memory	Size Flash Flash		120 kB Flash 0x0FFFF – 0x0FFC0 0x0FFFF – 0x02100
RAM (total)	Size		4 kB 0x020FF -- 0x01100
Extended	Size		2 kB 0x020FF -- 0x01900
Mirrored	Size		2 kB 0x018FF -- 0x01100
Information memory	Size Flash		256 Byte 0x010FF – 0x01000
Boot memory	Size ROM		1 kB 0x0FFF – 0x0C00
RAM (mirrored at 18FFh to 01100h)	Size		2 kB 0x009FF – 0x0200
Peripherals	16-bit 8-bit 8-bit SFR		0x001FF – 0x00100 0x000FF – 0x00010 0x0000F – 0x00000

## Bootstrap Loader (BSL)

The MSP430 bootstrap loader (BSL) enables users to program the flash memory or RAM using a UART serial interface. Access to the MSP430 memory via the BSL is protected by user-defined password. For complete description of the features of the BSL and its implementation, see the application report, *Features of the MSP430 Bootstrap Loader*, TI literature number [SLAA089](#).

BSL Function	PM Package Pins
Data Transmit	13 - P1.1
Data Receive	22 - P2.2

## Flash Memory

The flash memory can be programmed via the JTAG port, the bootstrap loader or in-system by the CPU. The CPU can perform single-byte and single-word writes to the flash memory. Features of the flash memory include:

- Flash memory has *n* segments of main memory and four segments of information memory (A to D) of 64 bytes each. Each segment in main memory is 512 bytes in size.
- Segments 0 to *n* may be erased in one step, or each segment may be individually erased.
- Segments A to D can be erased individually, or as a group with segments 0–*n*. Segments A to D are also called *information memory*.
- Segment A contains calibration data. After reset segment A is protected against programming and erasing. It can be unlocked but care should be taken not to erase this segment if the device-specific calibration data is required.
- Flash content integrity check with marginal read modes.

## Peripherals

Peripherals are connected to the CPU through data, address, and control busses and can be handled using all instructions. For complete module descriptions, refer to the *MSP430x2xx Family User's Guide (SLAU144)*.

### DMA Controller

The DMA controller allows movement of data from one memory address to another without CPU intervention. For example, the DMA controller can be used to move data from the ADC12 conversion memory to RAM. Using the DMA controller can increase the throughput of peripheral modules. The DMA controller reduces system power consumption by allowing the CPU to remain in sleep mode without having to awaken to move data to or from a peripheral.

### Oscillator and System Clock

The clock system is supported by the basic clock module that includes support for a 32768-Hz watch crystal oscillator, an internal very low power, low frequency oscillator and an internal digitally-controlled oscillator (DCO). The basic clock module is designed to meet the requirements of both low system cost and low-power consumption. The internal DCO provides a fast turn-on clock source and stabilizes in less than 1  $\mu$ s. The basic clock module provides the following clock signals:

- Auxiliary clock (ACLK), sourced either from a 32768-Hz watch crystal or the internal LF oscillator for  $-55^{\circ}\text{C}$  to  $105^{\circ}\text{C}$  operation. For  $> 105^{\circ}\text{C}$ , use external clock source.
- Main clock (MCLK), the system clock used by the CPU
- Sub-Main clock (SMCLK), the sub-system clock used by the peripheral modules

The DCO settings to calibrate the DCO output frequency are stored in the information memory segment A.

**Table 5. Tags Used by the TLV Structure**

NAME	ADDRESS	VALUE	DESCRIPTION
TAG_DCO_30	0x10F6	0x01	DCO frequency calibration at $V_{CC} = 3\text{ V}$ and $T_A = 25^{\circ}\text{C}$ at calibration
TAG_ADC12_1	0x10DA	0x08	ADC12_1 calibration tag
TAG_EMPTY	--	0xFE	Identifier for empty areas

**Table 6. Labels Used by the ADC Calibration Structure**

LABEL	CONDITION AT CALIBRATION/DESCRIPTION	SIZE	ADDRESS OFFSET
CAL_ADC_25T85	INCHx = 0x1010; REF2_5 = 1, $T_A = 125^{\circ}\text{C}$	word	0x000E
CAL_ADC_25T30	INCHx = 0x1010; REF2_5 = 1, $T_A = 30^{\circ}\text{C}$	word	0x000C
CAL_ADC_25VREF_FACTOR	REF2_5 = 1, $T_A = 30^{\circ}\text{C}$	word	0x000A
CAL_ADC_15T85	INCHx = 0x1010; REF2_5 = 0, $T_A = 125^{\circ}\text{C}$	word	0x0008
CAL_ADC_15T30	INCHx = 0x1010; REF2_5 = 0, $T_A = 30^{\circ}\text{C}$	word	0x0006
CAL_ADC_15VREF_FACTOR	REF2_5 = 0, $T_A = 30^{\circ}\text{C}$	word	0x0004
CAL_ADC_OFFSET	External $V_{REF} = 1.5\text{ V}$ , $f_{ADC12CLK} = 5\text{ MHz}$	word	0x0002
CAL_ADC_GAIN_FACTOR	External $V_{REF} = 1.5$ , $f_{ADC12CLK} = 5\text{ MHz}$	word	0x0000
CAL_BC1_1MHZ	--	byte	0x0007
CAL_DCO_1MHZ	--	byte	0x0006
CAL_BC1_8MHZ	--	byte	0x0005
CAL_DCO_8MHZ	--	byte	0x0004
CAL_BC1_12MHZ	--	byte	0x0003
CAL_DCO_12MHZ	--	byte	0x0002
CAL_BC1_16MHZ	--	byte	0x0001
CAL_DCO_16MHZ	--	byte	0x0000

## Brownout, Supply Voltage Supervisor (SVS)

The brownout circuit is implemented to provide the proper internal reset signal to the device during power on and power off. The SVS circuitry detects if the supply voltage drops below a user selectable level and supports both supply voltage supervision (the device is automatically reset) and supply voltage monitoring (SVM) (the device is not automatically reset).

The CPU begins code execution after the brownout circuit releases the device reset. However,  $V_{CC}$  may not have ramped to  $V_{CC(min)}$  at that time. The user must ensure that the default DCO settings are not changed until VCC reaches  $V_{CC(min)}$ . If desired, the SVS circuit can be used to determine when  $V_{CC}$  reaches  $V_{CC(min)}$ .

## Digital I/O

There are six 8-bit I/O ports implemented – ports P1 through P6:

- All individual I/O bits are independently programmable.
- Any combination of input, output, and interrupt condition is possible.
- Edge-selectable interrupt input capability for all the eight bits of port P1 and P2.
- Read/write access to port-control registers is supported by all instructions.
- Each I/O has an individually programmable pullup/pulldown resistor.

## WDT+ Watchdog Timer

The primary function of the watchdog timer (WDT+) module is to perform a controlled system restart after a software problem occurs. If the selected time interval expires, a system reset is generated. If the watchdog function is not needed in an application, the module can be disabled or configured as an interval timer and can generate interrupts at selected time intervals.

## Hardware Multiplier

The multiplication operation is supported by a dedicated peripheral module. The module performs  $16 \times 16$ ,  $16 \times 8$ ,  $8 \times 16$ , and  $8 \times 8$  bit operations. The module is capable of supporting signed and unsigned multiplication as well as signed and unsigned multiply and accumulate operations. The result of an operation can be accessed immediately after the operands have been loaded into the peripheral registers. No additional clock cycles are required.

## USCI

The universal serial communication interface (USCI) module is used for serial data communication. The USCI module supports synchronous communication protocols like SPI (3 or 4 pin), I<sup>2</sup>C and asynchronous communication protocols like UART, enhanced UART with automatic baud-rate detection (LIN), and IrDA.

USCI\_A0 provides support for SPI (3 or 4 pin), UART, enhanced UART and IrDA.

USCI\_B0 provides support for SPI (3 or 4 pin) and I<sup>2</sup>C.

## Timer\_A3

Timer\_A3 is a 16-bit timer/counter with three capture/compare registers. Timer\_A3 can support multiple capture/compares, PWM outputs, and interval timing. Timer\_A3 also has extensive interrupt capabilities. Interrupts may be generated from the counter on overflow conditions and from each of the capture/compare registers.

**Table 7. TIMER\_A3 Signal Connections**

INPUT PIN NO.	DEVICE INPUT SIGNAL	MODULE INPUT NAME	MODULE BLOCK	MODULE U SIGNAL	OUTPUT PIN NO.
12 - P1.0	TACLK	TACLK	Timer	NA	
	ACLK	ACLK			
	SMCLK	SMCLK			
21 - P2.1	TAINCLK	INCLK			
13 - P1.1	TA0	CCI0A	CCR0	TA0	13 - P1.1
22 - P2.2	TA0	CCI0B			17 - P1.5
	DV <sub>SS</sub>	GND			27 - P2.7
	DV <sub>CC</sub>	V <sub>CC</sub>			
14 - P1.2	TA1	CCI1A	CCR1	TA1	14 - P1.2
	CAOUT (internal)	CCI1B			18 - P1.6
	DV <sub>SS</sub>	GND			23 - P2.3
	DV <sub>CC</sub>	V <sub>CC</sub>			ADC12 (internal)
					DAC12_0 (internal)
					DAC12_1 (internal)
15 - P1.3	TA2	CCI2A	CCR2	TA2	15 - P1.3
	ACLK (internal)	CCI2B			19 - P1.7
	DV <sub>SS</sub>	GND			24 - P2.4
	DV <sub>CC</sub>	V <sub>CC</sub>			

## Timer\_B7

Timer\_B7 is a 16-bit timer/counter with three capture/compare registers. Timer\_B7 can support multiple capture/comparers, PWM outputs, and interval timing. Timer\_B7 also has extensive interrupt capabilities. Interrupts may be generated from the counter on overflow conditions and from each of the capture/compare registers.

Timer_B7 Signal Connections						
INPUT PIN NO.	DEVICE INPUT SIGNAL	MODULE INPUT NAME	MODULE BLOCK	MODULE OUTPUT SIGNAL	OUTPUT PIN NO.	
43 - P4.7	TBCLK	TBCLK	Timer	NA		
	ACLK	ACLK				
	SMCLK	SMCLK				
43 - P4.7	$\overline{\text{TBCLK}}$	INCLK				
36 - P4.0	TB0	CCI0A	CCR0	TB0	36 - P4.0	
36 - P4.0	TB0	CCI0B			ADC12 (internal)	
	DV <sub>SS</sub>	GND				
	DV <sub>CC</sub>	V <sub>CC</sub>				
37 - P4.1	TB1	CCI1A	CCR1	TB1	37 - P4.1	
37 - P4.1	TB1	CCI1B			ADC12 (internal)	
	DV <sub>SS</sub>	GND				
	DV <sub>CC</sub>	V <sub>CC</sub>				
38 - P4.2	TB2	CCI2A	CCR2	TB2	38 - P4.2	
38 - P4.2	TB2	CCI2B			DAC_0 (internal)	
	DV <sub>SS</sub>	GND			DAC_1 (internal)	
	DV <sub>CC</sub>	V <sub>CC</sub>				
39 - P4.3	TB3	CCI3A	CCR3	TB3	39 - P4.3	
39 - P4.3	TB3	CCI3B				
	DV <sub>SS</sub>	GND				
	DV <sub>CC</sub>	V <sub>CC</sub>				
40 - P4.4	TB4	CCI4A	CCR4	TB4	40 - P4.4	
40 - P4.4	TB4	CCI4B				
	DV <sub>SS</sub>	GND				
	DV <sub>CC</sub>	V <sub>CC</sub>				
41 - P4.5	TB5	CCI5A	CCR5	TB5	41 - P4.5	
41 - P4.5	TB5	CCI5B				
	DV <sub>SS</sub>	GND				
	DV <sub>CC</sub>	V <sub>CC</sub>				
42 - P4.6	TB6	CCI6A	CCR6	TB6	42 - P4.6	
		ACLK (internal)			CCI6B	
		DV <sub>SS</sub>			GND	
		DV <sub>CC</sub>			V <sub>CC</sub>	

**Comparator\_A+**

The primary function of the comparator\_A+ module is to support precision slope analog-to-digital conversions, battery-voltage supervision, and monitoring of external analog signals.

**ADC12**

The ADC12 module supports fast 12-bit analog-to-digital conversions. The module implements a 12-bit SAR core, sample select control, reference generator, and a 16-word conversion-and-control buffer. The conversion-and-control buffer allows up to 16 independent ADC samples to be converted and stored without any CPU intervention.

**DAC12**

The DAC12 module is a 12-bit, R-ladder, voltage-output digital-to-analog converter (DAC). The DAC12 may be used in 8-bit or 12-bit mode and may be used in conjunction with the DMA controller. When multiple DAC12 modules are present, they may be grouped together for synchronous operation.

**Peripheral File Map**

<b>DMA</b>	DMA channel 2 transfer size	DMA2SZ	0x01F2
	DMA channel 2 destination address	DMA2DA	0x01EE
	DMA channel 2 source address	DMA2SA	0x01EA
	DMA channel 2 control	DMA2CTL	0x01E8
	DMA channel 1 transfer size	DMA1SZ	0x01E6
	DMA channel 1 destination address	DMA1DA	0x01E2
	DMA channel 1 source address	DMA1SA	0x01DE
	DMA channel 1 control	DMA1CTL	0x01DC
	DMA channel 0 transfer size	DMA0SZ	0x01DA
	DMA channel 0 destination address	DMA0DA	0x01D6
	DMA channel 0 source address	DMA0SA	0x01D2
	DMA channel 0 control	DMA0CTL	0x01D0
	DMA module interrupt vector word	DMAIV	0x0126
	DMA module control 1	DMACTL1	0x0124
	DMA module control 0	DMACTL0	0x0122
<b>DAC12</b>	DAC12_1 data	DAC12_1DAT	0x01CA
	DAC12_1 control	DAC12_1CTL	0x01C2
	DAC12_0 data	DAC12_0DAT	0x01C8
	DAC12_0 control	DAC12_0CTL	0x01C0

<b>ADC12</b>	Interrupt-vector-word register	ADC12IV	0x01A8
	Inerrupt-enable register	ADC12IE	0x01A6
	Inerrupt-flag register	ADC12IFG	0x01A4
	Control register 1	ADC12CTL1	0x01A2
	Control register 0	ADC12CTL0	0x01A0
	Conversion memory 15	ADC12MEM15	0x015E
	Conversion memory 14	ADC12MEM14	0x015C
	Conversion memory 13	ADC12MEM13	0x015A
	Conversion memory 12	ADC12MEM12	0x0158
	Conversion memory 11	ADC12MEM11	0x0156
	Conversion memory 10	ADC12MEM10	0x0154
	Conversion memory 9	ADC12MEM9	0x0152
	Conversion memory 8	ADC12MEM8	0x0150
	Conversion memory 7	ADC12MEM7	0x014E
	Conversion memory 6	ADC12MEM6	0x014C
	Conversion memory 5	ADC12MEM5	0x014A
	Conversion memory 4	ADC12MEM4	0x0148
	Conversion memory 3	ADC12MEM3	0x0146
	Conversion memory 2	ADC12MEM2	0x0144
	Conversion memory 1	ADC12MEM1	0x0142
	Conversion 0	ADC12MEM0	0x0140
	ADC memory-control register15	ADC12MCTL15	0x008F
	ADC memory-control register14	ADC12MCTL14	0x008E
	ADC memory-control register13	ADC12MCTL13	0x008D
	ADC memory-control register12	ADC12MCTL12	0x008C
	ADC memory-control register11	ADC12MCTL11	0x008B
	ADC memory-control register10	ADC12MCTL10	0x008A
	ADC memory-control register9	ADC12MCTL9	0x0089
	ADC memory-control register8	ADC12MCTL8	0x0088
	ADC memory-control register7	ADC12MCTL7	0x0087
	ADC memory-control register6	ADC12MCTL6	0x0086
	ADC memory-control register5	ADC12MCTL5	0x0085
	ADC memory-control register4	ADC12MCTL4	0x0084
	ADC memory-control register3	ADC12MCTL3	0x0083
	ADC memory-control register2	ADC12MCTL2	0x0082
	ADC memory-control register1	ADC12MCTL1	0x0081
	ADC memory-control register0	ADC12MCTL0	0x0080

<b>Timer_B7</b>	Capture/compare register _ 6	TBCCR6	0x019E
	Capture/compare register 5	TBCCR5	0x019C
	Capture/compare register 4	TBCCR4	0x019A
	Capture/compare register 3	TBCCR3	0x0198
	Capture/compare register 2	TBCCR2	0x0196
	Capture/compare register 1	TBCCR1	0x0194
	Capture/compare register 0	TBCCR0	0x0192
	Timer_B register	TBR	0x0190
	Capture/compare control 6	TBCCTL6	0x018E
	Capture/compare control 5	TBCCTL5	0x018C
	Capture/compare control 4	TBCCTL4	0x018A
	Capture/compare control 3	TBCCTL3	0x0188
	Capture/compare control 2	TBCCTL2	0x0186
	Capture/compare control 1	TBCCTL1	0x0184
	Capture/compare control 0	TBCCTL0	0x0182
	Timer_B control	TBCTL	0x0180
	Timer_B interrupt vector	TBIV	0x011E
<b>Timer_A3</b>	Capture/compare register 2	TACCR2	0x0176
	Capture/compare register 1	TACCR1	0x0174
	Capture/compare register 0	TACCR0	0x0172
	Timer_A register	TAR	0x0170
	Reserved		0x016E
	Reserved		0x016C
	Reserved		0x016A
	Reserved		0x0168
	Capture/compare control 2	TACCTL2	0x0166
	Capture/compare control 1	TACCTL1	0x0164
	Capture/compare control 0	TACCTL0	0x0162
	Timer_A control	TACTL	0x0160
Timer_A interrupt vector	TAIV	0x012E	
<b>Hardware Multiplier</b>	Sum extend	SUMEXT	0x013E
	Result high word	RESHI	0x013C
	Result low word	RESLO	0x013A
	Second operand	OP2	0x0138
	Multiply signed +accumulate/operand1	MACS	0x0136
	Multiply+accumulate/operand1	MAC	0x0134
	Multiply signed/operand1	MPYS	0x0132
	Multiply unsigned/operand1	MPY	0x0130
<b>Flash</b>	Flash control 4	FCTL4	0x01BE
	Flash control 3	FCTL3	0x012C
	Flash control 2	FCTL2	0x012A
	Flash control 1	FCTL1	0x0128
<b>Watchdog</b>	Watchdog/timer control	WDCTL	0x0120

<b>USCI A0/B0</b>	USCI A0 auto baud rate control	UCA0ABCTL	0x005D
	USCI A0 transmit buffer	UCA0TXBUF	0x0067
	USCI A0 receive buffer	UCA0RXBUF	0x0066
	USCI A0 status	UCA0STAT	0x0065
	USCI A0 modulation control	UCA0MCTL	0x0064
	USCI A0 baud rate control 1	UCA0BR1	0x0063
	USCI A0 baud rate control 0	UCA0BR0	0x0062
	USCI A0 control 1	UCA0CTL1	0x0061
	USCI A0 control 0	UCA0CTL0	0x0060
	USCI A0 IrDA receive control	UCA0IRRCTL	0x005F
	USCI A0 IrDA transmit control	UCA0IRTCLT	0x005E
	USCI B0 transmit buffer	UCB0TXBUF	0x006F
	USCI B0 receive buffer	UCB0RXBUF	0x006E
	USCI B0 status	UCB0STAT	0x006D
	USCI B0 I <sup>2</sup> C interrupt enable	UCB0CIE	0x006C
	USCI B0 baud rate control 1	UCB0BR1	0x006B
	USCI B0 baud rate control 0	UCB0BR0	0x006A
	USCI B0 control 1	UCB0CTL1	0x0069
	USCI B0 control 0	UCB0CTL0	0x0068
	USCI B0 I <sup>2</sup> C slave address	UCB0SA	0x011A
USCI B0 I <sup>2</sup> C own address	UCB0OA	0x0118	
<b>USCI A1/B1</b>	USCI A1 auto baud rate control	UCA1ABCTL	0x00CD
	USCI A1 transmit buffer	UCA1TXBUF	0x00D7
	USCI A1 receive buffer	UCA1RXBUF	0x00D6
	USCI A1 status	UCA1STAT	0x00D5
	USCI A1 modulation control	UCA1MCTL	0x00D4
	USCI A1 baud rate control 1	UCA1BR1	0x00D3
	USCI A1 baud rate control 0	UCA1BR0	0x00D2
	USCI A1 control 1	UCA1CTL1	0x00D1
	USCI A1 control 0	UCA1CTL0	0x00D0
	USCI A1 IrDA receive control	UCA1IRRCTL	0x00CF
	USCI A1 IrDA transmit control	UCA1IRTCLT	0x00CE
	USCI B1 transmit buffer	UCB1TXBUF	0x00DF
	USCI B1 receive buffer	UCB1RXBUF	0x00DE
	USCI B1 status	UCB1STAT	0x00DD
	USCI B1 I2C Interrupt enable	UCB1CIE	0x00DC
	USCI B1 baud rate control 1	UCB1BR1	0x00DB
	USCI B1 baud rate control 0	UCB1BR0	0x00DA
	USCI B1 control 1	UCB1CTL1	0x00D9
	USCI B1 control 0	UCB1CTL0	0x00D8
	USCI B1 I2C slave address	UCB1SA	0x017E
USCI B1 I2C own address	UCB1OA	0x017C	
USCI A1/B1 interrupt enable	UC1IE	0x0006	
USCI A1/B1 interrupt flag	UC1IFG	0x0007	
<b>Comparator_A+</b>	Comparator_A port disable	CAPD	0x005B
	Comparator_A control2	CACTL2	0x005A
	Comparator_A control1	CACTL1	0x0059

<b>Basic Clock</b>	Basic clock system control3	BCSCTL3	0x0053
	Basic clock system control2	BCSCTL2	0x0058
	Basic clock system control1	BCSCTL1	0x0057
	DCO clock frequency control	DCOCTL	0x0056
<b>Brownout, SVS</b>	SVS control register (reset by brownout signal)	SVSCTL	0x0055
<b>Port P6</b>	Port P6 resistor enable	P6REN	0x0013
	Port P6 selection	P6SEL	0x0037
	Port P6 direction	P6DIR	0x0036
	Port P6 output	P6OUT	0x0035
	Port P6 input	P6IN	0x0034
<b>Port P5</b>	Port P5 resistor enable	P5REN	0x0012
	Port P5 selection	P5SEL	0x0033
	Port P5 direction	P5DIR	0x0032
	Port P5 output	P5OUT	0x0031
	Port P5 input	P5IN	0x0030
<b>Port P4</b>	Port P4 selection	P4SEL	0x001F
	Port P4 resistor enable	P4REN	0x0011
	Port P4 direction	P4DIR	0x001E
	Port P4 output	P4OUT	0x001D
	Port P4 input	P4IN	0x001C
<b>Port P3</b>	Port P3 resistor enable	P3REN	0x0010
	Port P3 selection	P3SEL	0x001B
	Port P3 direction	P3DIR	0x001A
	Port P3 output	P3OUT	0x0019
	Port P3 input	P3IN	0x0018
<b>Port P2</b>	Port P2 resistor enable	P2REN	0x002F
	Port P2 selection	P2SEL	0x002E
	Port P2 interrupt enable	P2IE	0x002D
	Port P2 interrupt-edge select	P2IES	0x002C
	Port P2 interrupt flag	P2IFG	0x002B
	Port P2 direction	P2DIR	0x002A
	Port P2 output	P2OUT	0x0029
	Port P2 input	P2IN	0x0028
<b>Port P1</b>	Port P1 resistor enable	P1REN	0x0027
	Port P1 selection	P1SEL	0x0026
	Port P1 interrupt enable	P1IE	0x0025
	Port P1 interrupt-edge select	P1IES	0x0024
	Port P1 interrupt flag	P1IFG	0x0023
	Port P1 direction	P1DIR	0x0022
	Port P1 output	P1OUT	0x0021
	Port P1 input	P1IN	0x0020
<b>Special Functions</b>	SFR interrupt flag2	IFG2	0x0003
	SFR interrupt flag1	IFG1	0x0002
	SFR interrupt enable2	IE2	0x0001
	SFR interrupt enable1	IE1	0x0000

**Absolute Maximum Ratings<sup>(1)</sup>**

	VALUE	UNIT
Voltage applied at V <sub>CC</sub> to V <sub>SS</sub>	-0.3 to 4.1	V
Voltage applied to any pin <sup>(2)</sup>	-0.3 to V <sub>CC</sub> + 0.3	V
Diode current at any device terminal	±2	mA
Storage temperature, T <sub>stg</sub> (unprogrammed device <sup>(3)</sup> )	-55 to 150	°C
Storage temperature, T <sub>stg</sub> (programmed device <sup>(3)</sup> )	-55 to 150	°C

- (1) Stresses beyond those listed under *absolute maximum ratings* may cause permanent damage to the device. These are stress ratings only, and functional operation of the device at these or any other conditions beyond those indicated under *recommended operating conditions* is not implied. Exposure to absolute-maximum-rated conditions for extended periods may affect device reliability.
- (2) All voltages referenced to VSS. The JTAG fuse-blow voltage, V<sub>FB</sub>, is allowed to exceed the absolute maximum rating. The voltage is applied to the TEST pin when blowing the JTAG fuse.
- (3) Higher temperature may be applied during board soldering process according to the current JEDEC J-STD-020 specification with peak reflow temperatures not higher than classified on the device label on the shipping boxes or reels.

**Recommended Operating Conditions<sup>(1) (2)</sup>**

			MIN	NOM	MAX	UNIT
V <sub>CC</sub>	Supply voltage during program execution	AV <sub>CC</sub> = DV <sub>CC</sub> = V <sub>CC</sub> <sup>(3)</sup>	1.8		3.6	V
	Supply voltage during flash memory programming		2.2		3.6	V
V <sub>SS</sub>	Supply voltage	AV <sub>SS</sub> = DV <sub>SS</sub> = V <sub>SS</sub>		0		V
T <sub>A</sub>	Operating free-air temperature range		-55		150	°C
	Processor frequency f <sub>SYSTEM</sub> (Maximum MCLK frequency) <sup>(1) (2)</sup> (see Figure 1)	V <sub>CC</sub> = 2.2 V, Duty Cycle = 50% ±10%	dc		10	MHz
		V <sub>CC</sub> = 2.7 V, Duty Cycle = 50% ±10%	dc		12	
		V <sub>CC</sub> ≥ 3.3 V, Duty Cycle = 50% ±10%	dc		16	

- (1) The MSP430 CPU is clocked directly with MCLK. Both the high and low phase of MCLK must not exceed the pulse width of the specified maximum frequency.
- (2) Modules might have a different maximum input clock specification. Refer to the specification of the respective module in this data sheet.
- (3) It is recommended to power AV<sub>CC</sub> and DV<sub>CC</sub> from the same source. A maximum difference of 0.3 V between AV<sub>CC</sub> and DV<sub>CC</sub> can be tolerated during power-up.

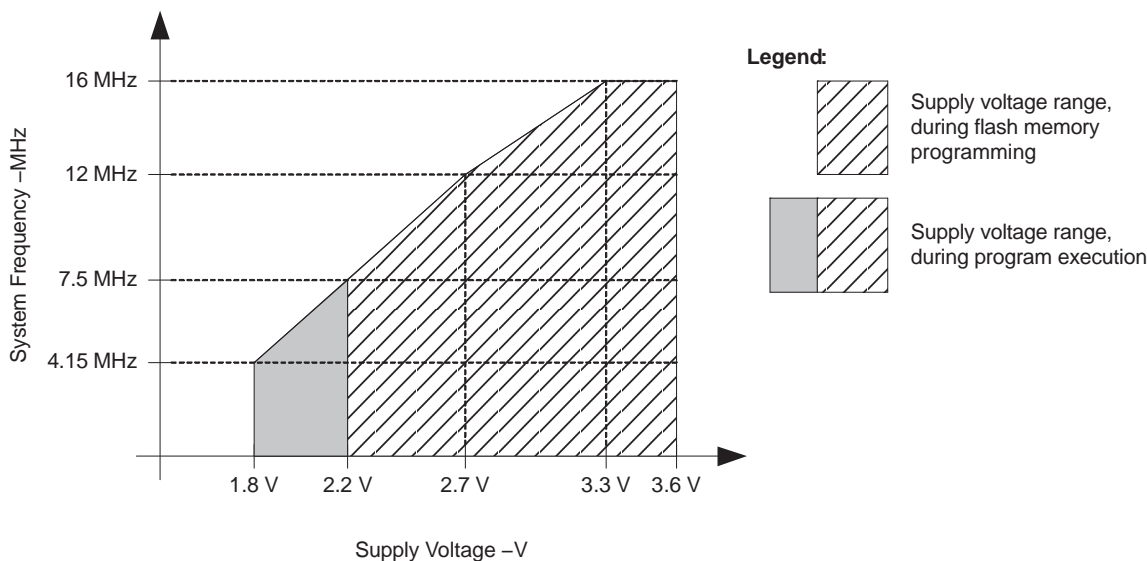

NOTE: Minimum processor frequency is defined by system clock. Flash program or erase operations require a minimum V<sub>CC</sub> of 2.2 V.

**Figure 1. Operating Area**

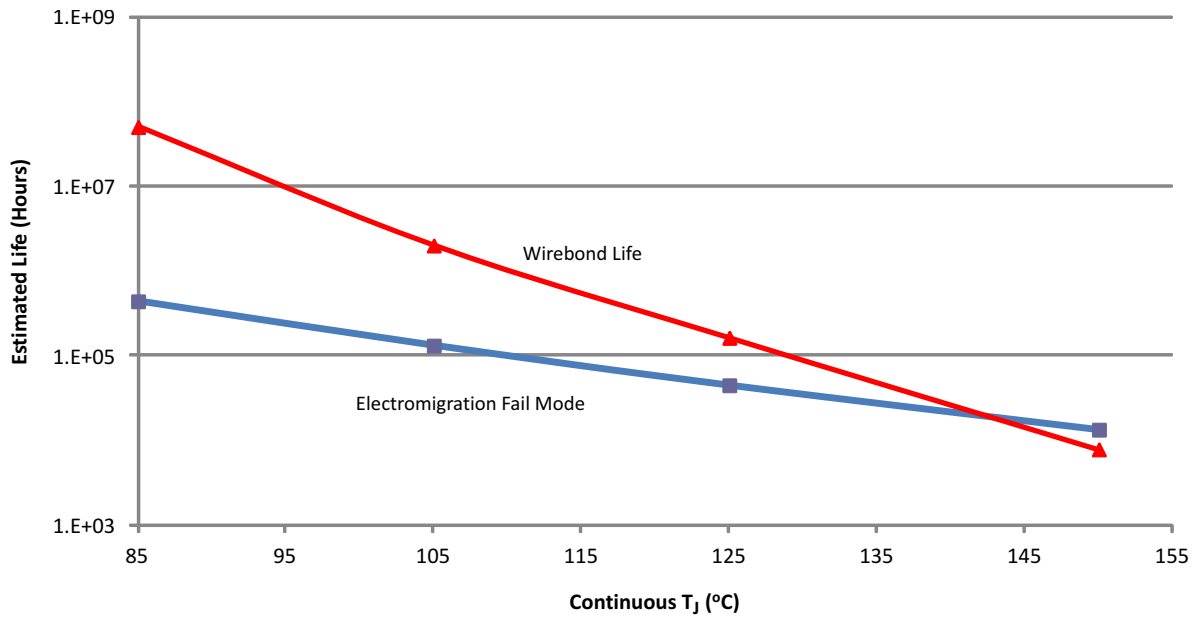

- (1) Wirebond Life = Time at temperature with or without bias
- (2) Electromigration Fail Mode = Time at temperature with bias
- (3) Silicon operating life design goal is 10 years at 105°C junction temperature (does not include package interconnect life).
- (4) The predicted operating lifetime vs. junction temperature is based on reliability modeling and available qualification data.

**Figure 2. Device Life Curve**

**Active-Mode Supply Current Into AV<sub>CC</sub> Excluding External Current – Electrical Characteristics<sup>(1) (2)</sup>**

over recommended ranges of supply voltage and operating free-air temperature (unless otherwise noted)

PARAMETER	TEST CONDITIONS	T <sub>A</sub>	V <sub>CC</sub>	MIN	TYP	MAX	UNIT
I <sub>AM, 1MHz</sub> Active-mode (AM) current (1 MHz)	f <sub>DCO</sub> = f <sub>MCLK</sub> = f <sub>SMCLK</sub> = 1 MHz, f <sub>ACLK</sub> = 32,768 Hz, Program executes in flash, BCSTL1 = CALBC1_1 MHZ, DCOCTL = CALDCO_1 MHZ, CPUOFF = 0, SCG0 = 0, SCG1 = 0, OSCOFF = 0	–55°C to 85°C	2.2 V		365	395	μA
		105°C			375	420	
		150°C			640		
		–55°C to 85°C	3 V		515	560	
		105°C			525	595	
		150°C			700		
I <sub>AM, 1MHz</sub> Active-mode (AM) current (1 MHz)	f <sub>DCO</sub> = f <sub>MCLK</sub> = f <sub>SMCLK</sub> = 1 MHz, f <sub>ACLK</sub> = 32,768 Hz, Program executes in RAM, BCSTL1 = CALBC1_1 MHZ, DCOCTL = CALDCO_1 MHZ, CPUOFF = 0, SCG0 = 0, SCG1 = 0, OSCOFF = 0	–55°C to 85°C	2.2 V		330	370	μA
		105°C			340	390	
		150°C			660		
		–55°C to 85°C	3 V		460	495	
		105°C			470	520	
		150°C			710		
I <sub>AM, 4kHz</sub> Active-mode (AM) current (4 kHz)	f <sub>MCLK</sub> = f <sub>SMCLK</sub> = f <sub>ACLK</sub> = 32,768 Hz/8 = 4,096 Hz, f <sub>DCO</sub> = 0 Hz, Program executes in flash, SELMx = 11, SELS = 1, DIVMx = DIVSx = DIVAx = 11, CPUOFF = 0, SCG0 = 1, SCG1 = 0, OSCOFF = 0	–55°C to 85°C	2.2 V		2.1	9	μA
		105°C			15	31	
		–55°C to 85°C	3 V		3	11	
		105°C			19	32	
I <sub>AM, 100kHz</sub> Active-mode (AM) current (100 kHz)	f <sub>MCLK</sub> = f <sub>SMCLK</sub> = f <sub>DCO(0, 0)</sub> ≠ 100 kHz, f <sub>ACLK</sub> = 0 Hz, Program executes in flash, RSELx = 0, DCOx = 0, CPUOFF = 0, SCG0 = 0, SCG1 = 0, OSCOFF = 1	–55°C to 85°C	2.2 V		67	86	μA
		105°C			80	99	
		150°C			190		
		–55°C to 85°C	3 V		84	107	
		105°C			99	128	
		150°C			240		

- (1) All inputs are tied to 0 V or V<sub>CC</sub>. Outputs do not source or sink any current.
- (2) The currents are characterized with a Micro Crystal CC4V-T1A SMD crystal with a load capacitance of 9 pF. The internal and external load capacitance is chosen to closely match the required 9 pF.

Typical Characteristics – Active-Mode Supply Current (Into DV<sub>CC</sub> + AV<sub>CC</sub>)

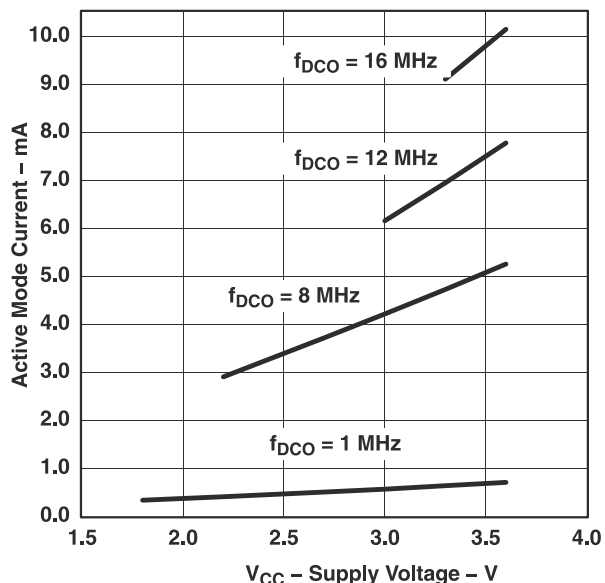

Figure 3. Active-Mode Current vs V<sub>CC</sub>, T<sub>A</sub> = 25°C

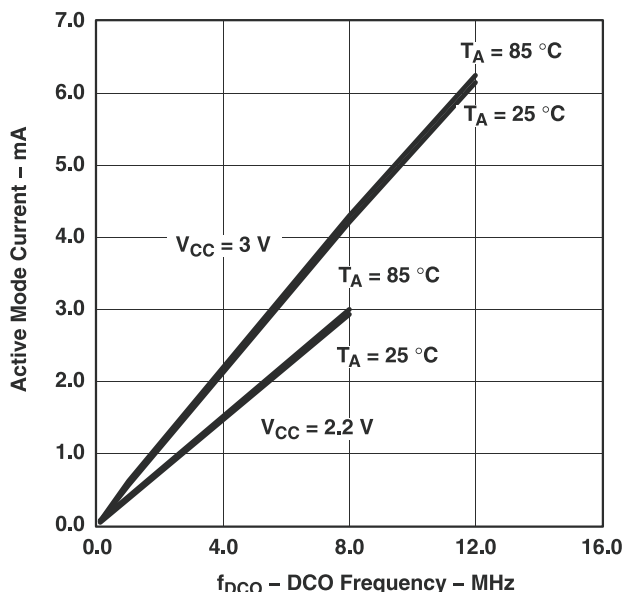

Figure 4. Active-Mode Current vs DCO Frequency

Active-Mode Current vs DCO Frequency

over recommended ranges of supply voltage and operating free-air temperature (unless otherwise noted)

PARAMETER	TEST CONDITIONS	T <sub>A</sub>	V <sub>CC</sub>	MIN	TYP	MAX	UNIT
Active Mode Current Supply	f <sub>SMCLK</sub> = f <sub>DCO</sub> = 1 MHz	-55°C	2.2 V			0.35	mA
		-40°C				0.30	
		25°C				0.36	
		125°C				0.38	
		150°C				0.42	
		-55°C	3 V			0.50	
		-40°C				0.49	
		25°C				0.51	
		125°C				0.55	
		150°C				0.60	
Active Mode Current Supply	f <sub>SMCLK</sub> = f <sub>DCO</sub> = 12 MHz	-55°C	2.2 V			3.71	mA
		-40°C				3.73	
		25°C				3.79	
		125°C				4.45	
		150°C				4.60	
		-55°C	3 V			5.47	
		-40°C				5.49	
		25°C				5.54	
		125°C				5.68	
		150°C				5.77	

### Active-Mode Current vs DCO Frequency (continued)

over recommended ranges of supply voltage and operating free-air temperature (unless otherwise noted)

PARAMETER	TEST CONDITIONS	T <sub>A</sub>	V <sub>CC</sub>	MIN	TYP	MAX	UNIT
Active Mode Current Supply	f <sub>SMCLK</sub> = f <sub>DCO</sub> = 16 MHz	-55°C	2.2 V			5.46	mA
		-40°C				5.58	
		25°C				5.89	
		125°C				6.03	
		150°C				6.20	
		-55°C	3 V			7.14	
		-40°C				7.14	
		25°C				7.21	
		125°C				7.429	
		150°C				7.54	

### Low-Power-Mode Supply Currents Into AV<sub>CC</sub> Excluding External Current – Electrical Characteristics<sup>(1) (2)</sup>

over recommended ranges of supply voltage and operating free-air temperature (unless otherwise noted)

PARAMETER	TEST CONDITIONS	T <sub>A</sub>	V <sub>CC</sub>	MIN	TYP	MAX	UNIT
I <sub>LPM0, 1MHz</sub> Low-power mode 0 (LPM0) current <sup>(3)</sup>	f <sub>MCLK</sub> = 0 MHz, f <sub>SMCLK</sub> = f <sub>DCO</sub> = 1 MHz, f <sub>ACLK</sub> = 32,768 Hz, BCSCTL1 = CALBC1_1 MHz, DCOCTL = CALDCO_1 MHz, CPUOFF = 1, SCG0 = 0, SCG1 = 0, OSCOFF = 0	-55°C to 85°C	2.2 V		68	83	μA
		105°C			83	98	
		150°C			210		
		-55°C to 85°C	3 V		87	105	
		105°C			100	125	
		150°C			240		
I <sub>LPM0, 100kHz</sub> Low-power mode 0 (LPM0) current <sup>(3)</sup>	f <sub>MCLK</sub> = 0 MHz, f <sub>SMCLK</sub> = f <sub>DCO(0, 0)</sub> ≠ 100 kHz, f <sub>ACLK</sub> = 0 Hz, RSELX = 0, DCOx = 0, CPUOFF = 1, SCG0 = 0, SCG1 = 0, OSCOFF = 1	-55°C to 85°C	2.2 V		37	49	μA
		105°C			50	62	
		150°C			160		
		-55°C to 85°C	3 V		40	55	
		105°C			57	73	
		150°C			185		
I <sub>LPM2</sub> Low-power mode 2 (LPM2) current <sup>(4)</sup>	f <sub>MCLK</sub> = f <sub>SMCLK</sub> = 0 MHz, f <sub>DCO</sub> = 1 MHz, f <sub>ACLK</sub> = 32,768 Hz, BCSCTL1 = CALBC1_1 MHz, DCOCTL = CALDCO_1 MHz, CPUOFF = 1, SCG0 = 0, SCG1 = 1, OSCOFF = 0	-55°C to 85°C	2.2 V		23	33	μA
		105°C			35	46	
		150°C			148		
		-55°C to 85°C	3 V		25	36	
		105°C			40	55	
		150°C			168		
I <sub>LPM3, LFXT1</sub> Low-power mode 3 (LPM3) current <sup>(4)</sup>	f <sub>DCO</sub> = f <sub>MCLK</sub> = f <sub>SMCLK</sub> = 0 MHz, f <sub>ACLK</sub> = 32,768 Hz, CPUOFF = 1, SCG0 = 1, SCG1 = 1, OSCOFF = 0	-55°C	2.2 V		0.8	1.2	μA
		25°C			1	1.3	
		85°C			4.6	7	
		105°C			14	24	
		-55°C	3 V		0.9	1.3	
		25°C			1.1	1.5	
		85°C			5.5	8	
		105°C			17	30	

(1) All inputs are tied to 0 V or V<sub>CC</sub>. Outputs do not source or sink any current.

(2) The currents are characterized with a Micro Crystal CC4V-T1A SMD crystal with a load capacitance of 9 pF. The internal and external load capacitance is chosen to closely match the required 9 pF.

(3) Current for brownout and WDT clocked by SMCLK included.

(4) Current for brownout and WDT clocked by ACLK included.

### Low-Power-Mode Supply Currents Into AV<sub>CC</sub> Excluding External Current – Electrical Characteristics<sup>(1) (2)</sup> (continued)

over recommended ranges of supply voltage and operating free-air temperature (unless otherwise noted)

PARAMETER	TEST CONDITIONS	T <sub>A</sub>	V <sub>CC</sub>	MIN	TYP	MAX	UNIT
I <sub>LPM3,VLO</sub>	Low-power mode 3 current, (LPM3) <sup>(4)</sup>  f <sub>DCO</sub> = f <sub>MCLK</sub> = f <sub>SMCLK</sub> = 0 MHz, f <sub>ACLK</sub> from internal LF oscillator (VLO), CPUOFF = 1, SCG0 = 1, SCG1 = 1, OSCOFF = 0	-55°C	2.2 V	0.4		1	μA
		25°C		0.5		1	
		85°C		4.3		6.5	
		105°C		14		24	
		150°C		125			
		-55°C	3 V	0.6		1.2	
		25°C		0.6		1.2	
		85°C		5		7.5	
		105°C		16.5		29.5	
		150°C		130			
I <sub>LPM4</sub>	Low-power mode 4 (LPM4) current <sup>(5)</sup>  f <sub>DCO</sub> = f <sub>MCLK</sub> = f <sub>SMCLK</sub> = 0 MHz, f <sub>ACLK</sub> = 0 Hz, CPUOFF = 1, SCG0 = 1, SCG1 = 1, OSCOFF = 1	-55°C	2.2 V	0.1		0.5	μA
		25°C		0.1		0.5	
		85°C		4		6	
		105°C		13		23	
		150°C		125			
		-55°C	3 V	0.2		0.5	
		25°C		0.2		0.5	
		85°C		4.7		7	
		105°C		14		24	
		150°C		146			

(5) Current for brownout included.

### Typical Characteristics – LPM4 Current

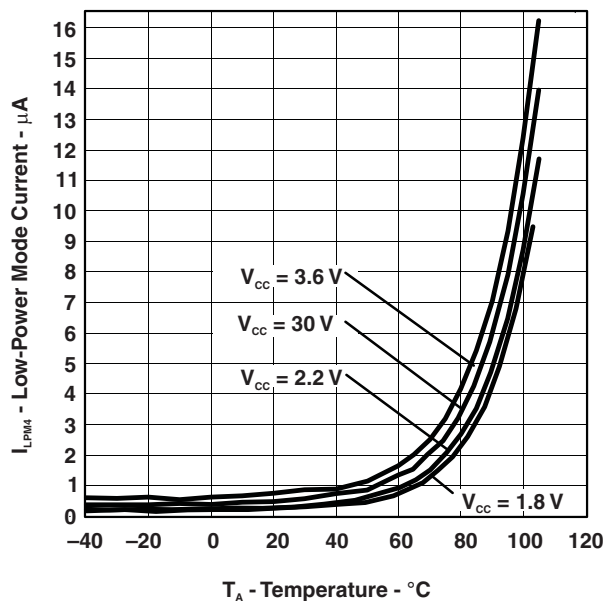

Figure 5. I<sub>LPM4</sub> -- LPM4 Current vs Temperature

## Schmitt-Trigger Inputs (Ports P1 Through P6, and $\overline{RST}/NMI$ , JTAG, XIN, and XT2IN)<sup>(1)</sup> – Electrical Characteristics

over recommended ranges of supply voltage and operating free-air temperature (unless otherwise noted)

PARAMETER	TEST CONDITIONS	V <sub>CC</sub>	MIN	TYP	MAX	UNIT
V <sub>IT+</sub> Positive-going input threshold voltage			0.45 x V <sub>CC</sub>		0.75 x V <sub>CC</sub>	V
		2.2 V	1.00		1.65	
		3 V	1.35		2.25	
V <sub>IT-</sub> Negative-going input threshold voltage			0.25 x V <sub>CC</sub>		0.55 x V <sub>CC</sub>	V
		2.2 V	0.55		1.20	
		3 V	0.75		1.65	
V <sub>hys</sub> Input voltage hysteresis (V <sub>IT+</sub> – V <sub>IT-</sub> )		2.2 V	0.2		1	V
		3 V	0.3		1	
R <sub>Pull</sub> Pullup/pulldown resistor	For pullup: V <sub>IN</sub> = V <sub>SS</sub> ; For pulldown: V <sub>IN</sub> = V <sub>CC</sub>		20	35	50	kΩ
C <sub>I</sub> Input capacitance	V <sub>IN</sub> = V <sub>SS</sub> or V <sub>CC</sub>			5		pF

(1) XIN and XT2IN in bypass mode only.

## Inputs (Ports P1 and P2) – Electrical Characteristics

over recommended ranges of supply voltage and operating free-air temperature (unless otherwise noted)

PARAMETER	TEST CONDITIONS	V <sub>CC</sub>	MIN	MAX	UNIT
t <sub>(int)</sub> External interrupt timing	Port P1, P2: P1.x to P2.x, External trigger pulse width to set interrupt flag <sup>(1)</sup>	2.2 V/3 V	20		ns

(1) An external signal sets the interrupt flag every time the minimum interrupt pulse width t<sub>(int)</sub> is met. It may be set even with trigger signals shorter than t<sub>(int)</sub>.

## Leakage Current (Ports P1 Through P6) – Electrical Characteristics

over recommended ranges of supply voltage and operating free-air temperature (unless otherwise noted)

PARAMETER	TEST CONDITIONS	V <sub>CC</sub>	MIN	TYP	MAX	UNIT
I <sub>Ikg(Px.x)</sub> High-impedance leakage current	See (1) and (2)	2.2 V/3 V		±250		nA

(1) The leakage current is measured with V<sub>SS</sub> or V<sub>CC</sub> applied to the corresponding pin(s), unless otherwise noted.

(2) The leakage of the digital port pins is measured individually. The port pin is selected for input and the pullup/pulldown resistor is disabled.

## Standard Inputs - $\overline{RST}/NMI$ – Electrical Characteristics

over recommended ranges of supply voltage and operating free-air temperature (unless otherwise noted)

PARAMETER	TEST CONDITIONS	V <sub>CC</sub>	MIN	MAX	UNIT
V <sub>IL</sub> Low-level input voltage		2.2 V/3 V	V <sub>SS</sub>	V <sub>SS</sub> + 0.6	V
V <sub>IH</sub> High-level input voltage		2.2 V/3 V	0.8 x V <sub>CC</sub>	V <sub>CC</sub>	V

## Outputs (Ports P1 Through P6) – Electrical Characteristics

over recommended ranges of supply voltage and operating free-air temperature (unless otherwise noted)

PARAMETER		TEST CONDITIONS	V <sub>CC</sub>	MIN	MAX	UNIT
V <sub>OH</sub>	High-level output voltage	I <sub>OH(max)</sub> = -1.5 mA <sup>(1)</sup>	2.2 V	V <sub>CC</sub> - 0.25	V <sub>CC</sub>	V
		I <sub>OH(max)</sub> = -6 mA <sup>(2)</sup>		V <sub>CC</sub> - 0.6	V <sub>CC</sub>	
		I <sub>OH(max)</sub> = -1.5 mA <sup>(1)</sup>	3 V	V <sub>CC</sub> - 0.25	V <sub>CC</sub>	
		I <sub>OH(max)</sub> = -6 mA <sup>(2)</sup>		V <sub>CC</sub> - 0.6	V <sub>CC</sub>	
V <sub>OL</sub>	Low-level output voltage	I <sub>OL(max)</sub> = 1.5 mA <sup>(1)</sup>	2.2 V	V <sub>SS</sub>	V <sub>SS</sub> +0.25	V
		I <sub>OL(max)</sub> = 6 mA <sup>(2)</sup>		V <sub>SS</sub>	V <sub>SS</sub> +0.6	
		I <sub>OL(max)</sub> = 1.5 mA <sup>(1)</sup>	3 V	V <sub>SS</sub>	V <sub>SS</sub> +0.25	
		I <sub>OL(max)</sub> = 6 mA <sup>(2)</sup>		V <sub>SS</sub>	V <sub>SS</sub> +0.6	

- (1) The maximum total current, I<sub>OH(max)</sub> and I<sub>OL(max)</sub>, for all outputs combined, should not exceed ±12 mA to hold the maximum voltage drop specified.
- (2) The maximum total current, I<sub>OH(max)</sub> and I<sub>OL(max)</sub>, for all outputs combined, should not exceed ±48 mA to hold the maximum voltage drop specified.

## Output Frequency (Ports P1 Through P6) – Electrical Characteristics

over recommended ranges of supply voltage and operating free-air temperature (unless otherwise noted)

PARAMETER		TEST CONDITIONS	V <sub>CC</sub>	MIN	TYP	MAX	UNIT
f <sub>Px,y</sub>	Port output frequency (with load)	P1.4/SMCLK, C <sub>L</sub> = 20 pF, R <sub>L</sub> = 1 kΩ <sup>(1)</sup> <sup>(2)</sup>	2.2 V	DC		10	MHz
			3 V	DC		12	
f <sub>Port_CLK</sub>	Clock output frequency	P2.0/ACLK/CA2, P1.4/SMCLK, C <sub>L</sub> = 20 pF <sup>(2)</sup>	2.2 V	DC		12	MHz
			3 V	DC		16	
t <sub>(Xdc)</sub>	Duty cycle of output frequency	P5.6/ACLK, C <sub>L</sub> = 20 pF, LF mode		30	50	70	%
		P5.6/ACLK, C <sub>L</sub> = 20 pF, XT1 mode		40	50	60	
		P5.4/MCLK, C <sub>L</sub> = 20 pF, XT1 mode		40		60	
		P5.4/MCLK, C <sub>L</sub> = 20 pF, DCO		50-15 ns	50	50+15 ns	
		P1.4/SMCLK, C <sub>L</sub> = 20 pF, XT2 mode		40		60	
		P1.4/SMCLK, C <sub>L</sub> = 20 pF, DCO		50-15 ns		50+15 ns	

- (1) A resistive divider with 2 times 0.5 kΩ between V<sub>CC</sub> and V<sub>SS</sub> is used as load. The output is connected to the center tap of the divider.
- (2) The output voltage reaches at least 10% and 90% V<sub>CC</sub> at the specified toggle frequency.

Typical Characteristics – Outputs

TYPICAL LOW-LEVEL OUTPUT CURRENT  
vs  
LOW-LEVEL OUTPUT VOLTAGE

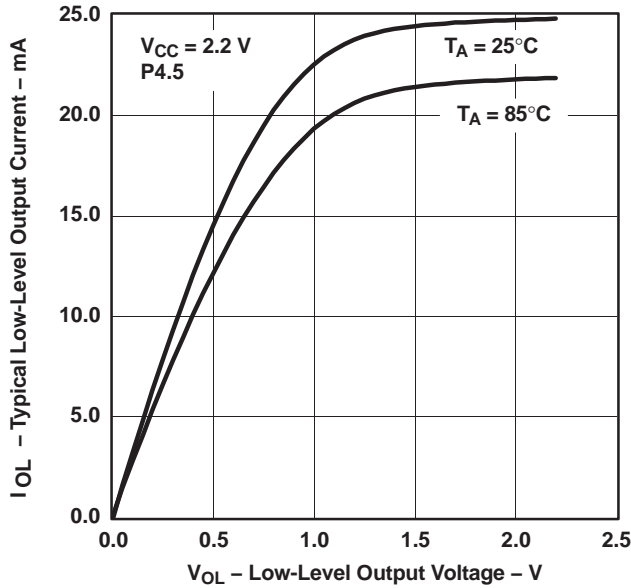

Figure 6.

TYPICAL LOW-LEVEL OUTPUT CURRENT  
vs  
LOW-LEVEL OUTPUT VOLTAGE

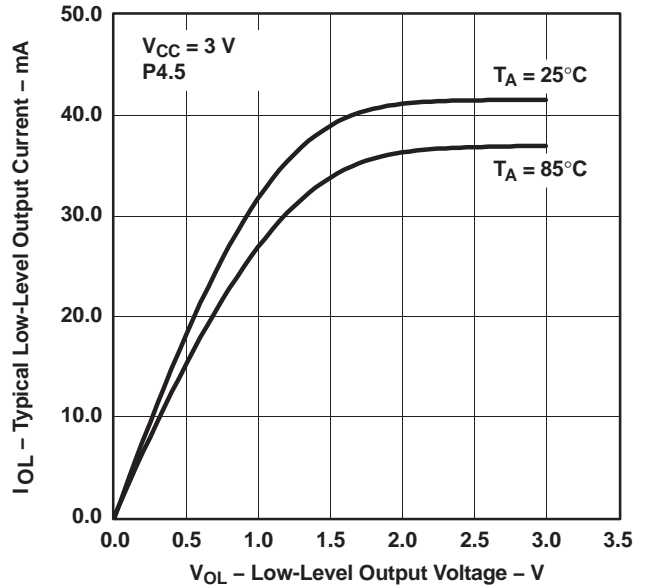

Figure 7.

TYPICAL HIGH-LEVEL OUTPUT CURRENT  
vs  
HIGH-LEVEL OUTPUT VOLTAGE

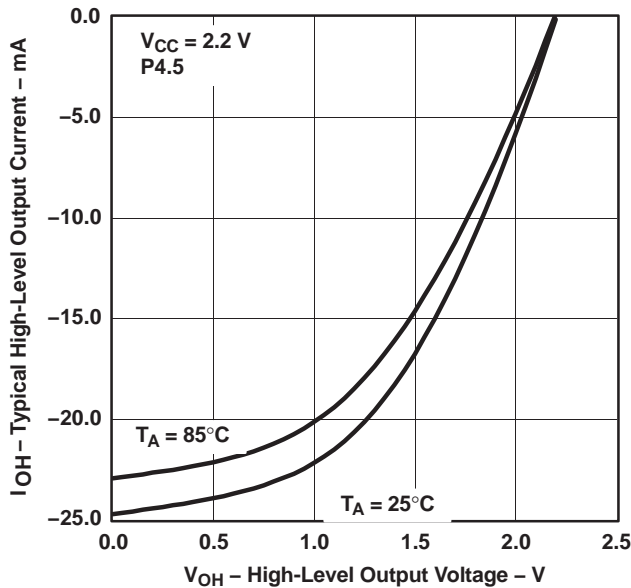

Figure 8.

TYPICAL HIGH-LEVEL OUTPUT CURRENT  
vs  
HIGH-LEVEL OUTPUT VOLTAGE

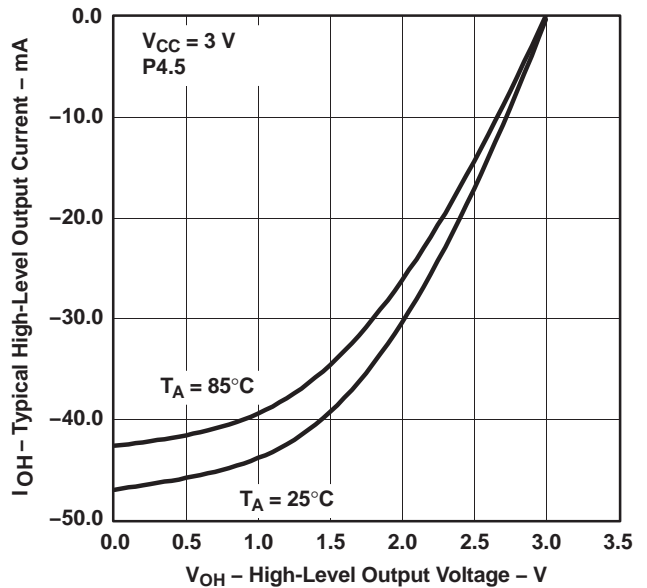

Figure 9.

**POR/Brownout Reset (BOR) – Electrical Characteristics<sup>(1) (2)</sup>**

over recommended ranges of supply voltage and operating free-air temperature (unless otherwise noted)

PARAMETER		TEST CONDITIONS	V <sub>CC</sub>	MIN	TYP	MAX	UNIT
V <sub>CC(start)</sub>	See Figure 10	dV <sub>CC</sub> /dt ≤ 3 V/s			0.7 × V <sub>(B_IT-)</sub>		V
V <sub>(B_IT-)</sub>	See Figure 10 through Figure 12	dV <sub>CC</sub> /dt ≤ 3 V/s				1.71	V
V <sub>hys(B_IT-)</sub>	See Figure 10	dV <sub>CC</sub> /dt ≤ 3 V/s		70	130	210	mV
t <sub>d(BOR)</sub>	See Figure 10					2000	μs
t <sub>(reset)</sub>	Pulse length needed at $\overline{\text{RST}}/\text{NMI}$ pin to accepted reset internally		2.2 V/3 V	2			μs

- (1) The current consumption of the brownout module is already included in the I<sub>CC</sub> current consumption data. The voltage level V<sub>(B\_IT-)</sub> + V<sub>hys(B\_IT-)</sub> is ≤ 1.8 V.
- (2) During power up, the CPU begins code execution following a period of t<sub>d(BOR)</sub> after V<sub>CC</sub> = V<sub>(B\_IT-)</sub> + V<sub>hys(B\_IT-)</sub>. The default DCO settings must not be changed until V<sub>CC</sub> ≥ V<sub>CC(min)</sub>, where V<sub>CC(min)</sub> is the minimum supply voltage for the desired operating frequency.

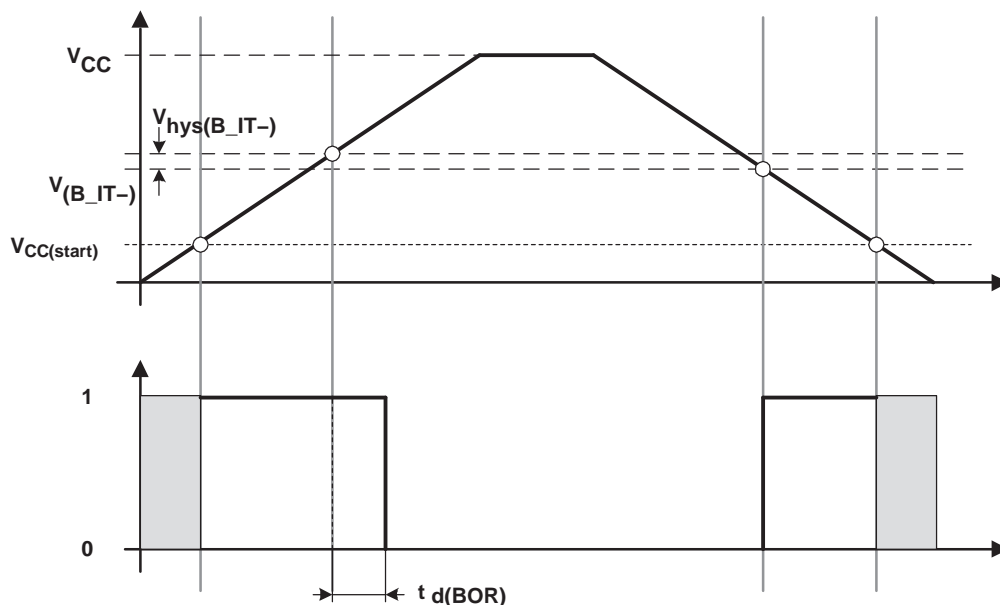

**Figure 10. POR/Brownout Reset (BOR) vs Supply Voltage**

Typical Characteristics - POR/Brownout Reset (BOR)

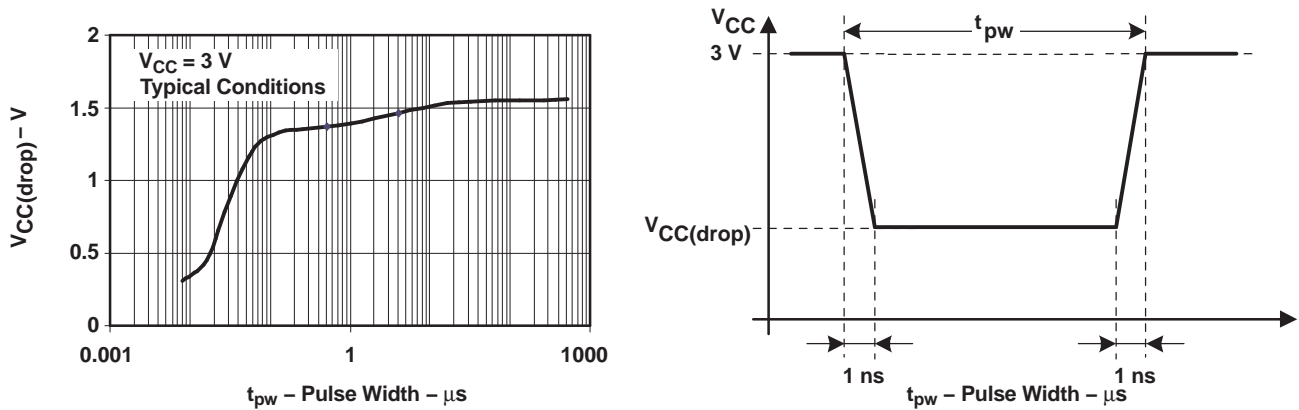

Figure 11.  $V_{CC(drop)}$  Level With a Square Voltage Drop to Generate a POR/Brownout Signal

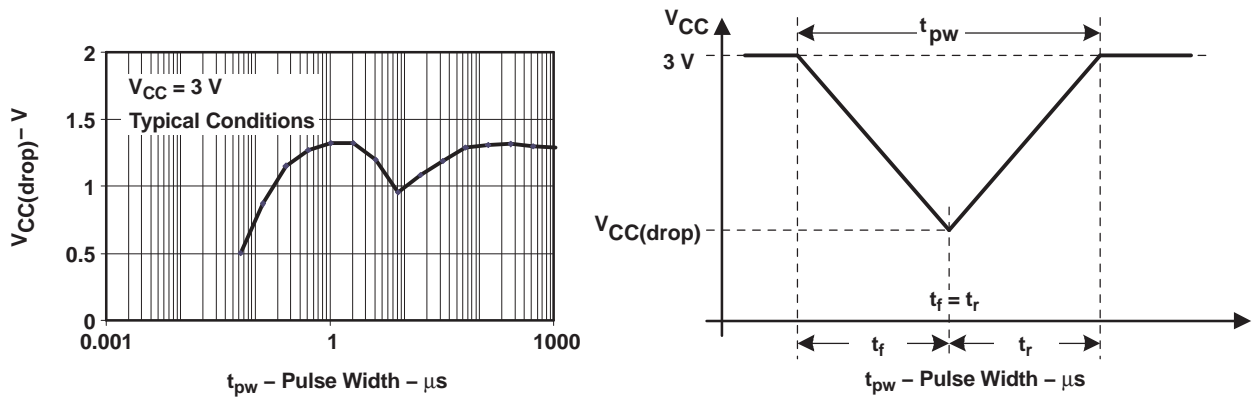

Figure 12.  $V_{CC(drop)}$  Level With a Triangle Voltage Drop to Generate a POR/Brownout Signal

SVS (Supply Voltage Supervisor/Monitor) - Electrical Characteristics

over operating free-air temperature range (unless otherwise noted)

PARAMETER	TEST CONDITIONS	MIN	TYP	MAX	UNIT	
$t_{(SVSR)}$	$dV_{CC}/dt > 30 \text{ V/ms}$ (See Figure 13)	5		150	$\mu\text{s}$	
	$dV_{CC}/dt \leq 30 \text{ V/ms}$			2000		
$t_{d(SVSON)}$	SVSON, switch from VLD = 0 to VLD $\neq$ 0, $V_{CC} = 3 \text{ V}$	20	150		$\mu\text{s}$	
$t_{settle}$	VLD $\neq$ 0 (See <sup>(1)</sup> )			12	$\mu\text{s}$	
$V_{(SVSstart)}$	VLD $\neq$ 0, $V_{CC}/dt \leq 3 \text{ V/s}$ (See Figure 13)		1.55	1.7	V	
$V_{hys(SVS\_IT-)}$	$V_{CC}/dt \leq 3 \text{ V/s}$ (See Figure 13)	VLD = 1	70	120	210	mV
		VLD = 2 to 14	$V_{(SVS\_IT-)} \times 0.004$		$V_{(SVS\_IT-)} \times 0.016$	V
	$V_{CC}/dt \leq 3 \text{ V/s}$ (See Figure 13), External voltage applied on A7	VLD = 15	4.4		20	mV

(1)  $t_{settle}$  is the settling time that the comparator o/p needs to have a stable level after VLD is switched VLD  $\neq$  0 to a different VLD value between 2 and 15. The overdrive is assumed to be  $> 50 \text{ mV}$ .

**SVS (Supply Voltage Supervisor/Monitor) - Electrical Characteristics (continued)**

over operating free-air temperature range (unless otherwise noted)

PARAMETER	TEST CONDITIONS	MIN	TYP	MAX	UNIT	
$V_{(SVS\_IT-)}$	$V_{CC}/dt \leq 3 \text{ V/s}$ (See Figure 13 and Figure 14)	VLD = 1	1.8	1.9	2.05	V
		VLD = 2	1.94	2.1	2.25	
		VLD = 3	2.05	2.2	2.37	
		VLD = 4	2.14	2.3	2.48	
		VLD = 5	2.24	2.4	2.6	
		VLD = 6	2.33	2.5	2.71	
		VLD = 7	2.46	2.65	2.86	
		VLD = 8	2.58	2.8	3	
		VLD = 9	2.69	2.9	3.13	
		VLD = 10	2.83	3.05	3.29	
		VLD = 11	2.94	3.2	3.42	
		VLD = 12	3.11	3.35	3.61 <sup>(2)</sup>	
		VLD = 13	3.24	3.5	3.76 <sup>(2)</sup>	
		VLD = 14	3.43	3.7 <sup>(2)</sup>	3.99 <sup>(2)</sup>	
		$V_{CC}/dt \leq 3 \text{ V/s}$ (See Figure 13 and Figure 14), External voltage applied on A7	VLD = 15	1.1	1.2	
$I_{CC(SVS)}$ <sup>(3)</sup>	VLD $\neq$ 0, $V_{CC} = 2.2 \text{ V}/3 \text{ V}$		10	15	$\mu\text{A}$	

(2) The recommended operating voltage range is limited to 3.6 V.

(3) The current consumption of the SVS module is not included in the  $I_{CC}$  current consumption data.

**Typical Characteristics - SVS**

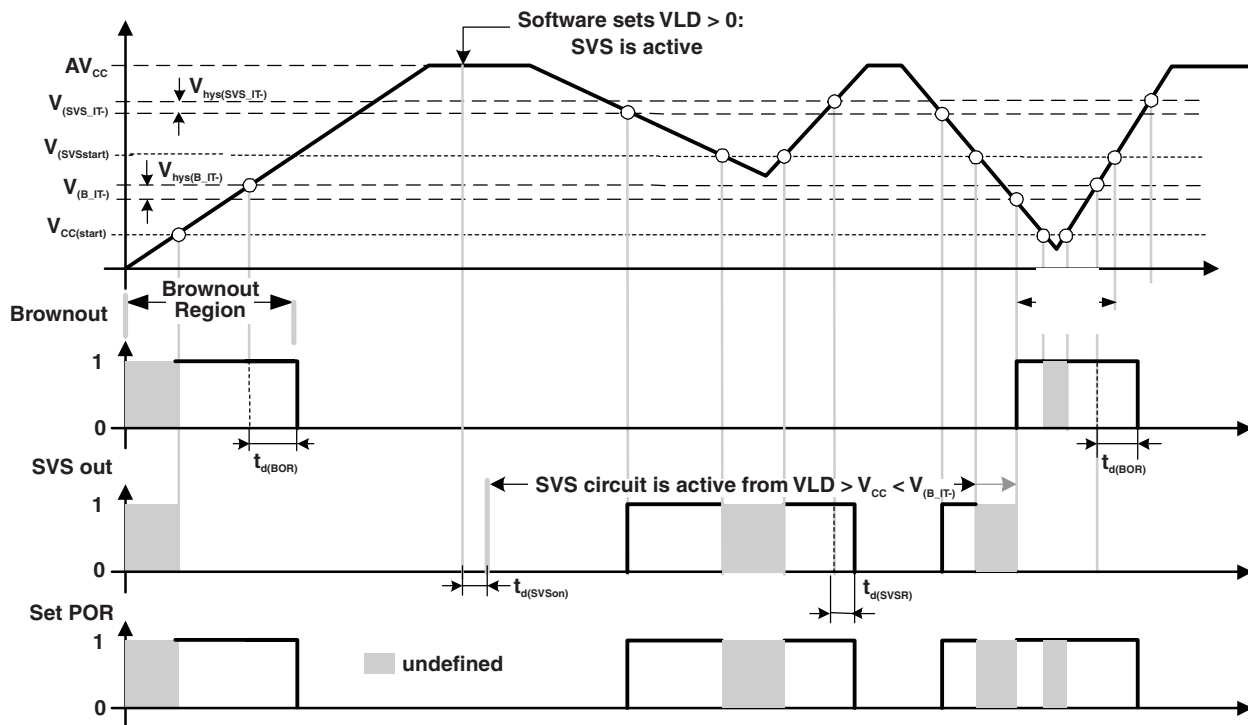

Figure 13. SVS Reset (SVSR) vs Supply Voltage

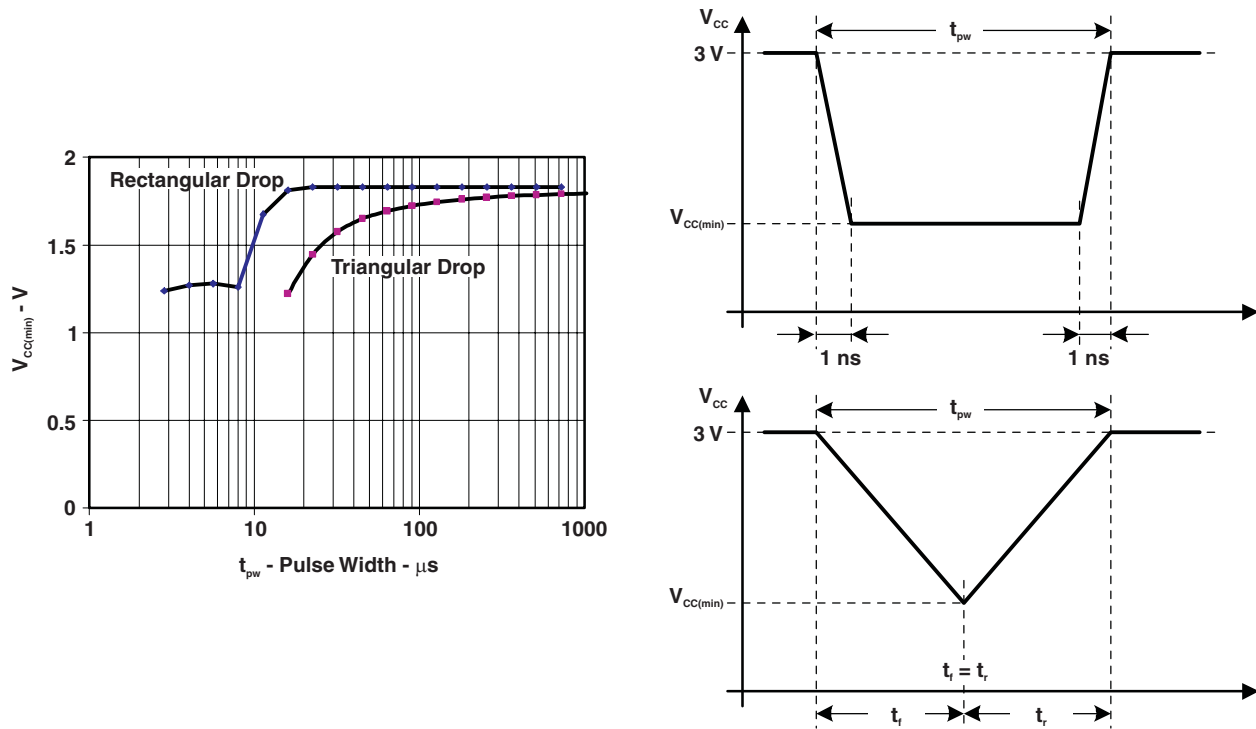

Figure 14.  $V_{CC(min)}$ : Square Voltage Drop and Triangle Voltage Drop to Generate an SVS Signal (VLD = 1)

## Main DCO Characteristics

- All ranges selected by RSELx overlap with RSELx + 1: RSELx = 0 overlaps RSELx = 1, ... RSELx = 14 overlaps RSELx = 15.
- DCO control bits DCOx have a step size as defined by parameter S<sub>DCO</sub>.
- Modulation control bits MODx select how often f<sub>DCO(RSEL,DCO+1)</sub> is used within the period of 32 DCOCLK cycles. The frequency f<sub>DCO(RSEL,DCO)</sub> is used for the remaining cycles. The frequency is an average equal to:

$$f_{\text{average}} = \frac{32 \times f_{\text{DCO(RSEL,DCO)}} \times f_{\text{DCO(RSEL,DCO)} + 1}}{\text{MOD} \times f_{\text{DCO(RSEL,DCO)}} + (32 - \text{MOD}) \times f_{\text{DCO(RSEL,DCO)} + 1}} \quad (1)$$

## DCO Frequency – Electrical Characteristics

over recommended ranges of supply voltage and operating free-air temperature (unless otherwise noted)

PARAMETER		TEST CONDITIONS	V <sub>CC</sub>	MIN	TYP	MAX	UNIT
V <sub>CC</sub>	Supply voltage range	RSELx < 14		1.8		3.6	V
		RSELx = 14		2.2		3.6	
		RSELx = 15		3.0		3.6	
f <sub>DCO(0,0)</sub>	DCO frequency (0, 0)	RSELx = 0, DCOx = 0, MODx = 0	2.2 V/3 V	0.06		0.14	MHz
f <sub>DCO(0,3)</sub>	DCO frequency (0, 3)	RSELx = 0, DCOx = 3, MODx = 0	2.2 V/3 V	0.07		0.17	MHz
f <sub>DCO(1,3)</sub>	DCO frequency (1, 3)	RSELx = 1, DCOx = 3, MODx = 0	2.2 V/3 V	0.10		0.20	MHz
f <sub>DCO(2,3)</sub>	DCO frequency (2, 3)	RSELx = 2, DCOx = 3, MODx = 0	2.2 V/3 V	0.14		0.28	MHz
f <sub>DCO(3,3)</sub>	DCO frequency (3, 3)	RSELx = 3, DCOx = 3, MODx = 0	2.2 V/3 V	0.20		0.40	MHz
f <sub>DCO(4,3)</sub>	DCO frequency (4, 3)	RSELx = 4, DCOx = 3, MODx = 0	2.2 V/3 V	0.28		0.54	MHz
f <sub>DCO(5,3)</sub>	DCO frequency (5, 3)	RSELx = 5, DCOx = 3, MODx = 0	2.2 V/3 V	0.39		0.77	MHz
f <sub>DCO(6,3)</sub>	DCO frequency (6, 3)	RSELx = 6, DCOx = 3, MODx = 0	2.2 V/3 V	0.54		1.06	MHz
f <sub>DCO(7,3)</sub>	DCO frequency (7, 3)	RSELx = 7, DCOx = 3, MODx = 0	2.2 V/3 V	0.80		1.50	MHz
f <sub>DCO(8,3)</sub>	DCO frequency (8, 3)	RSELx = 8, DCOx = 3, MODx = 0	2.2 V/3 V	1.10		2.10	MHz
f <sub>DCO(9,3)</sub>	DCO frequency (9, 3)	RSELx = 9, DCOx = 3, MODx = 0	2.2 V/3 V	1.60		3.00	MHz
f <sub>DCO(10,3)</sub>	DCO frequency (10, 3)	RSELx = 10, DCOx = 3, MODx = 0	2.2 V/3 V	2.50		4.30	MHz
f <sub>DCO(11,3)</sub>	DCO frequency (11, 3)	RSELx = 11, DCOx = 3, MODx = 0	2.2 V/3 V	3.00		5.50	MHz
f <sub>DCO(12,3)</sub>	DCO frequency (12, 3)	RSELx = 12, DCOx = 3, MODx = 0	2.2 V/3 V	4.30		7.30	M Hz
f <sub>DCO(13,3)</sub>	DCO frequency (13, 3)	RSELx = 13, DCOx = 3, MODx = 0	2.2 V/3 V	6.00		9.60	MHz
f <sub>DCO(14,3)</sub>	DCO frequency (14, 3)	RSELx = 14, DCOx = 3, MODx = 0	2.2 V/3 V	8.60		13.9	MHz
f <sub>DCO(15,3)</sub>	DCO frequency (15, 3)	RSELx = 15, DCOx = 3, MODx = 0	3 V	12.0		18.5	MHz
f <sub>DCO(15,7)</sub>	DCO frequency (15, 7)	RSELx = 15, DCOx = 7, MODx = 0	3 V	16.0		26.0	MHz
S <sub>RSEL</sub>	Frequency step between range RSEL and RSEL+1	S <sub>RSEL</sub> = f <sub>DCO(RSEL+1,DCO)</sub> /f <sub>DCO(RSEL,DCO)</sub>	2.2 V/3 V			1.55	ratio

### DCO Frequency – Electrical Characteristics (continued)

over recommended ranges of supply voltage and operating free-air temperature (unless otherwise noted)

PARAMETER		TEST CONDITIONS	V <sub>CC</sub>	MIN	TYP	MAX	UNIT
S <sub>DCO</sub>	Frequency step between tap DCO and DCO+1	S <sub>DCO</sub> = f <sub>DCO(RSEL,DCO+1)</sub> /f <sub>DCO(RSEL,DCO)</sub>	2.2 V/3 V	1.05	1.08	1.12	ratio
Duty cycle		Measured at P1.4/SMCLK	2.2 V/3 V	40	50	60	%

### Calibrated DCO Frequencies (Tolerance at Calibration) – Electrical Characteristics

over recommended ranges of supply voltage and operating free-air temperature (unless otherwise noted)

PARAMETER		TEST CONDITIONS	T <sub>A</sub>	V <sub>CC</sub>	MIN	TYP	MAX	UNIT
Frequency tolerance at calibration			25°C	3 V	-1	±0.2	1	%
f <sub>CAL(1 MHz)</sub>	1-MHz calibration value	BCSCTL1 = CALBC1_1MHZ, DCOCTL = CALDCO_1MHZ, Gating time: 5 ms	25°C	3 V	0.990	1	1.010	MHz
f <sub>CAL(8 MHz)</sub>	8-MHz calibration value	BCSCTL1 = CALBC1_8MHZ, DCOCTL = CALDCO_8MHZ, Gating time: 5 ms	25°C	3 V	7.920	8	8.080	MHz
f <sub>CAL(12 MHz)</sub>	12-MHz calibration value	BCSCTL1 = CALBC1_12MHZ, DCOCTL = CALDCO_12MHZ, Gating time: 5 ms	25°C	3 V	11.88	12	12.12	MHz
f <sub>CAL(16 MHz)</sub>	16-MHz calibration value	BCSCTL1 = CALBC1_16MHZ, DCOCTL = CALDCO_16MHZ, Gating time: 2 ms	25°C	3 V	15.84	16	16.16	MHz

### Calibrated DCO Frequencies (Tolerance Over Temperature) – Electrical Characteristics

over recommended ranges of supply voltage and operating free-air temperature (unless otherwise noted)

PARAMETER		TEST CONDITIONS	T <sub>A</sub>	V <sub>CC</sub>	MIN	TYP	MAX	UNIT
1-MHz tolerance over temperature			0°C to 85°C	3 V	-2.5	±0.5	2.5	%
8-MHz tolerance over temperature			0°C to 85°C	3 V	-2.5	±1.0	2.5	%
12-MHz tolerance over temperature			0°C to 85°C	3 V	-2.5	±1.0	2.5	%
16-MHz tolerance over temperature			0°C to 85°C	3 V	-3.0	±2.0	3.0	%
f <sub>CAL(1MHz)</sub>	1-MHz calibration value	BCSCTL1 = CALBC1_1MHZ, DCOCTL = CALDCO_1MHZ, Gating time: 5 ms	0°C to 85°C	2.2 V	0.970	1	1.030	MHz
				3 V	0.975	1	1.025	
				3.6 V	0.970	1	1.030	
f <sub>CAL(8MHz)</sub>	8-MHz calibration value	BCSCTL1 = CALBC1_8MHZ, DCOCTL = CALDCO_8MHZ, Gating time: 5 ms	0°C to 85°C	2.2 V	7.760	8	8.400	MHz
				3 V	7.800	8	8.200	
				3.6 V	7.600	8	8.240	
f <sub>CAL(12MHz)</sub>	12-MHz calibration value	BCSCTL1 = CALBC1_12MHZ, DCOCTL = CALDCO_12MHZ, Gating time: 5 ms	0°C to 85°C	2.2 V	11.70	12	12.30	MHz
				3 V	11.70	12	12.30	
				3.6 V	11.70	12	12.30	
f <sub>CAL(16MHz)</sub>	16-MHz calibration value	BCSCTL1 = CALBC1_16MHZ, DCOCTL = CALDCO_16MHZ, Gating time: 2 ms	0°C to 85°C	3 V	15.52	16	16.48	MHz
				3.6 V	15.00	16	16.48	

### Calibrated DCO Frequencies (Tolerance Over Supply Voltage $V_{CC}$ ) – Electrical Characteristics

over recommended ranges of supply voltage and operating free-air temperature (unless otherwise noted)

PARAMETER	TEST CONDITIONS	$T_A$	$V_{CC}$	MIN	TYP	MAX	UNIT
1-MHz tolerance over $V_{CC}$		25°C	1.8 V to 3.6 V	-3	±2	3	%
8-MHz tolerance over $V_{CC}$		25°C	1.8 V to 3.6 V	-3	±2	3	%
12-MHz tolerance over $V_{CC}$		25°C	2.2 V to 3.6 V	-3	±2	3	%
16-MHz tolerance over $V_{CC}$		25°C	3 V to 3.6 V	-6	±2	3	%
$f_{CAL(1MHz)}$ 1-MHz calibration value	BCSCTL1 = CALBC1_1MHZ, DCOCTL = CALDCO_1MHZ, Gating time: 5 ms	25°C	1.8 V to 3.6 V	0.970	1	1.030	MHz
$f_{CAL(8MHz)}$ 8-MHz calibration value	BCSCTL1 = CALBC1_8MHZ, DCOCTL = CALDCO_8MHZ, Gating time: 5 ms	25°C	1.8 V to 3.6 V	7.760	8	8.240	MHz
$f_{CAL(12MHz)}$ 12-MHz calibration value	BCSCTL1 = CALBC1_12MHZ, DCOCTL = CALDCO_12MHZ, Gating time: 5 ms	25°C	2.2 V to 3.6 V	11.64	12	12.36	MHz
$f_{CAL(16MHz)}$ 16-MHz calibration value	BCSCTL1 = CALBC1_16MHZ, DCOCTL = CALDCO_16MHZ, Gating time: 2 ms	25°C	3 V to 3.6 V	15.00	16	16.48	MHz

### Calibrated DCO Frequencies (Overall Tolerance) – Electrical Characteristics

over recommended ranges of supply voltage and operating free-air temperature (unless otherwise noted)

PARAMETER	TEST CONDITIONS	$T_A$	$V_{CC}$	MIN	TYP	MAX	UNIT
1-MHz tolerance over temperature		-55°C to 150°C	1.8 V to 3.6 V	-5	±2	+5	%
8-MHz tolerance over temperature		-55°C to 150°C	1.8 V to 3.6 V	-5	±2	+5	%
12-MHz tolerance over temperature		-55°C to 150°C	2.2 V to 3.6 V	-5	±2	+5	%
16-MHz tolerance over temperature		-55°C to 150°C	3 V to 3.6 V	-6	±3	+6	%
$f_{CAL(1MHz)}$ 1-MHz calibration value	BCSCTL1 = CALBC1_1MHZ, DCOCTL = CALDCO_1MHZ, Gating time: 5 ms	-55°C to 150°C	1.8 V to 3.6 V	.950	1	1.050	MHz
$f_{CAL(8MHz)}$ 8-MHz calibration value	BCSCTL1 = CALBC1_8MHZ, DCOCTL = CALDCO_8MHZ, Gating time: 5 ms	-55°C to 150°C	1.8 V to 3.6 V	7.6	8	8.4	MHz
$f_{CAL(12MHz)}$ 12-MHz calibration value	BCSCTL1 = CALBC1_12MHZ, DCOCTL = CALDCO_12MHZ, Gating time: 5 ms	-55°C to 150°C	2.2 V to 3.6 V	11.4	12	12.6	MHz
$f_{CAL(16MHz)}$ 16-MHz calibration value	BCSCTL1 = CALBC1_16MHZ, DCOCTL = CALDCO_16MHZ, Gating time: 2 ms	-55°C to 150°C	3 V to 3.6 V	15.00	16	17.00	MHz

Typical Characteristics – Calibrated 1-MHz DCO Frequency

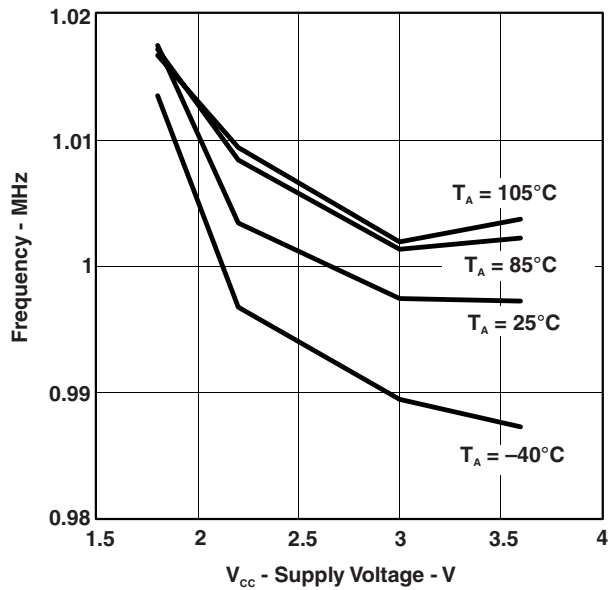

Figure 15. Calibrated 1-MHz Frequency vs V<sub>CC</sub>

Typical Characteristics – Calibrated 8-MHz DCO Frequency

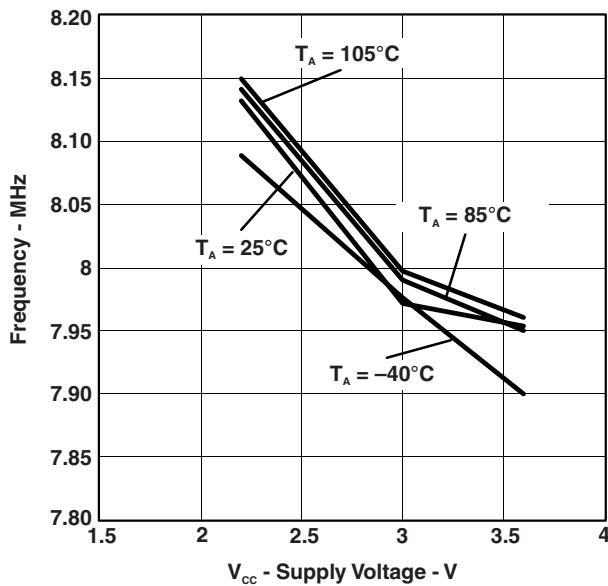

Figure 16. Calibrated 8-MHz Frequency vs V<sub>CC</sub>

Typical Characteristics – Calibrated 12-MHz DCO Frequency

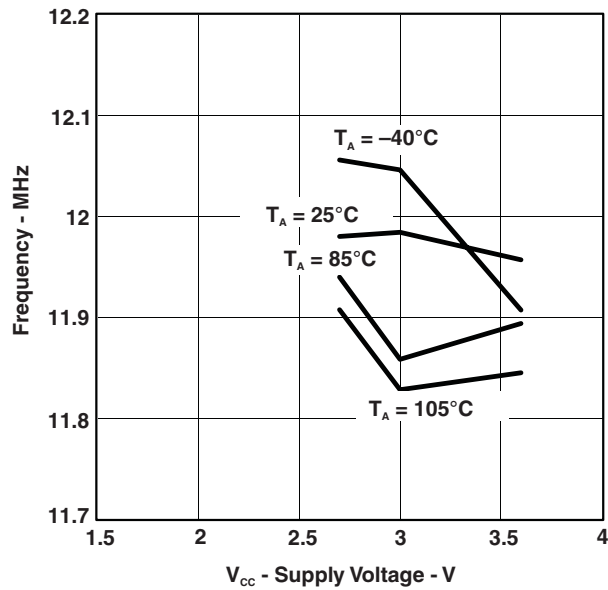

Figure 17. Calibrated 12-MHz Frequency vs V<sub>CC</sub>

Typical Characteristics – Calibrated 16-MHz DCO Frequency

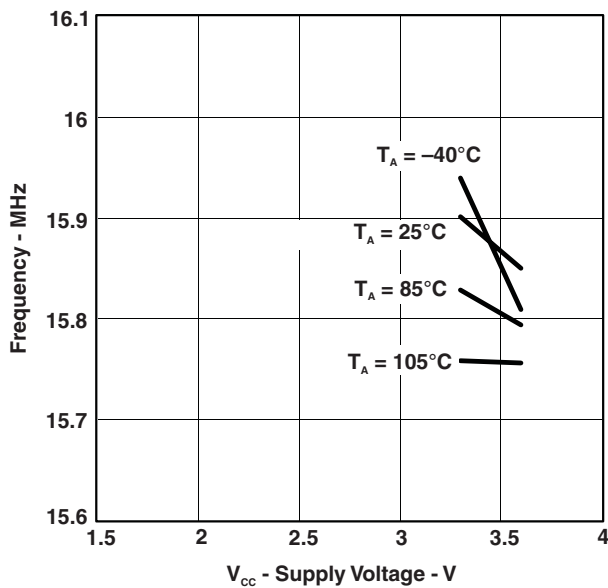

Figure 18. Calibrated 16-MHz Frequency vs V<sub>CC</sub>

## Wake-Up From Low-Power Modes (LPM3/4) – Electrical Characteristics

over recommended ranges of supply voltage and operating free-air temperature (unless otherwise noted)

PARAMETER	TEST CONDITIONS	V <sub>CC</sub>	MIN	TYP	MAX	UNIT
t <sub>DCO,LPM3/4</sub> DCO clock wake-up time from LPM3/4 <sup>(1)</sup>	BCSCTL1 = CALBC1_1MHZ, DCOCTL = CALDCO_1MHZ,	2.2 V/3 V			2	μs
	BCSCTL1 = CALBC1_8MHZ, DCOCTL = CALDCO_8MHZ,	2.2 V/3 V			1.5	
	BCSCTL1 = CALBC1_12MHZ, DCOCTL = CALDCO_12MHZ,	3 V			1	
	BCSCTL1 = CALBC1_16MHZ, DCOCTL = CALDCO_16MHZ,	3 V			1	
t <sub>CPU,LPM3/4</sub> CPU wake-up time from LPM3/4 <sup>(2)</sup>				1/f <sub>MCLK</sub> + t <sub>Clock,LPM3/4</sub>		

- (1) The DCO clock wake-up time is measured from the edge of an external wake-up signal (e.g., port interrupt) to the first clock edge observable externally on a clock pin (MCLK or SMCLK).  
 (2) Parameter applicable only if DCOCLK is used for MCLK.

## Typical Characteristics – DCO Clock Wake-Up Time From LPM3/4

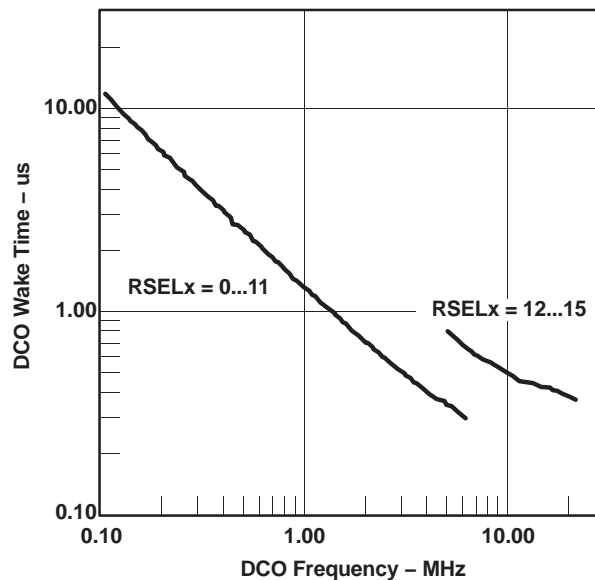

Figure 19. Clock Wake-Up Time From LPM3 vs DCO Frequency

## DCO With External Resistor R<sub>OSC</sub> – Electrical Characteristics<sup>(1)</sup>

over recommended ranges of supply voltage and operating free-air temperature (unless otherwise noted)

PARAMETER	TEST CONDITIONS	V <sub>CC</sub>	TYP	UNIT
f <sub>DCO,ROSC</sub> DCO output frequency with R <sub>OSC</sub>	DCOR = 1, RSELx = 4, DCOx = 3, MODx = 0, T <sub>A</sub> = 25°C	2.2 V	1.8	MHz
		3 V	1.95	
D <sub>t</sub> Temperature drift	DCOR = 1, RSELx = 4, DCOx = 3, MODx = 0	2.2 V/3 V	±0.1	%/°C
D <sub>V</sub> Drift with V <sub>CC</sub>	DCOR = 1, RSELx = 4, DCOx = 3, MODx = 0	2.2 V/3 V	10	%/V

- (1) R<sub>OSC</sub> = 100 kΩ. Metal film resistor, type 0257. 0.6 watt with 1% tolerance and T<sub>K</sub> = ±50 ppm/°C

Typical Characteristics - DCO With External Resistor  $R_{OSC}$

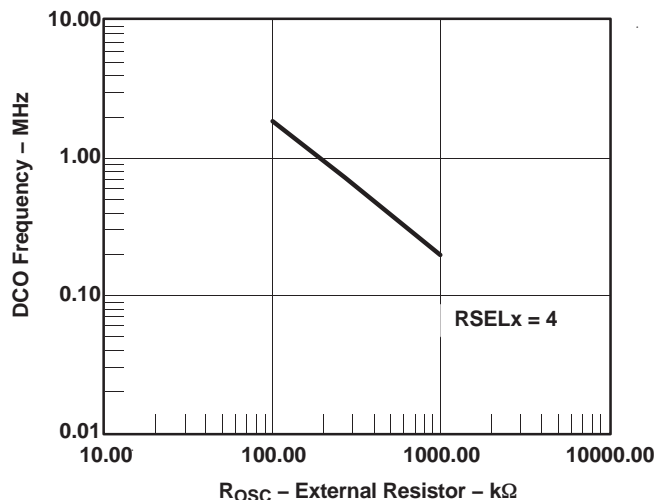

Figure 20. DCO Frequency vs  $R_{OSC}$ ,  $V_{CC} = 2.2\text{ V}$ ,  $T_A = 25^\circ\text{C}$

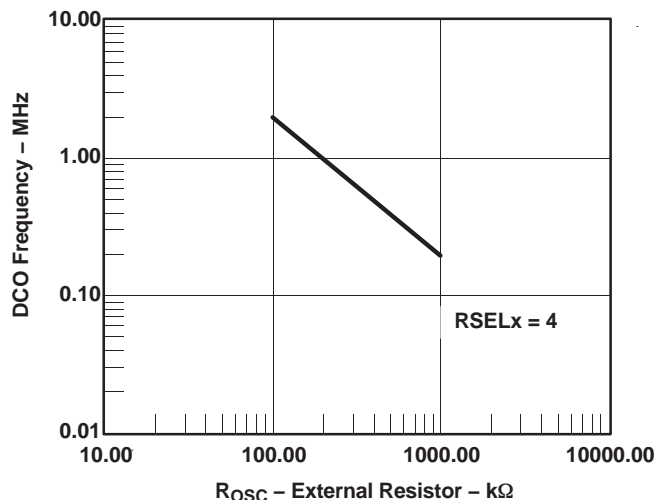

Figure 21. DCO Frequency vs  $R_{OSC}$ ,  $V_{CC} = 3.0\text{ V}$ ,  $T_A = 25^\circ\text{C}$

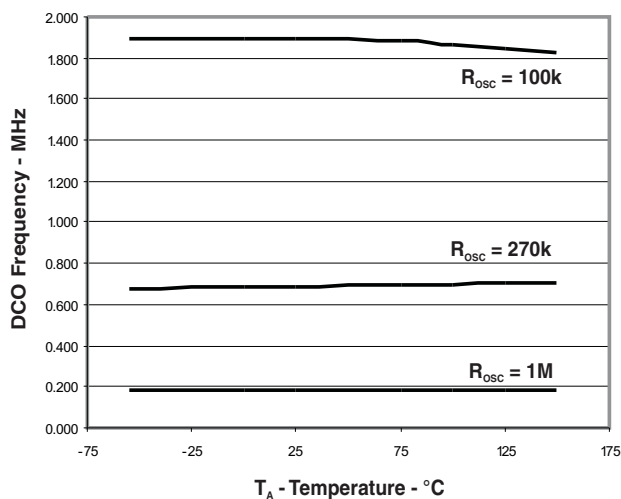

Figure 22. DCO Frequency vs Temperature,  $V_{CC} = 3.0\text{ V}$

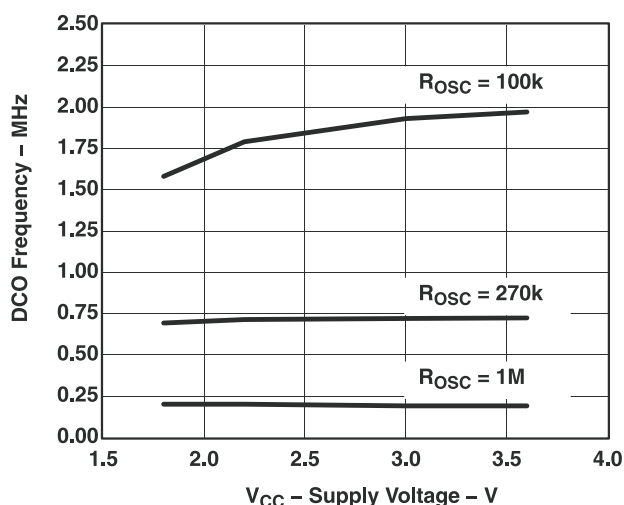

Figure 23. DCO Frequency vs  $V_{CC}$ ,  $T_A = 25^\circ\text{C}$

## Crystal Oscillator (LFXT1) Low-Frequency Modes – Electrical Characteristics<sup>(1) (2)(2)</sup>

over recommended ranges of supply voltage and operating free-air temperature (unless otherwise noted)

PARAMETER		TEST CONDITIONS	V <sub>CC</sub>	MIN	TYP	MAX	UNIT
f <sub>LFXT1,LF</sub>	LFXT1 oscillator crystal frequency, LF mode 0, 1	XTS = 0, LFXT1Sx = 0 or 1	1.8 V to 3.6 V		32,768		Hz
f <sub>LFXT1,LF,logic</sub>	LFXT1 oscillator logic-level square-wave input frequency, LF mode	XTS = 0, LFXT1Sx = 3	1.8 V to 3.6 V	10,000	32,768	50,000	Hz
OA <sub>LF</sub>	Oscillation allowance for LF crystals	XTS = 0, LFXT1Sx = 0; f <sub>LFXT1,LF</sub> = 32,768 kHz, C <sub>L,eff</sub> = 6 pF			500		kΩ
		XTS = 0, LFXT1Sx = 0; f <sub>LFXT1,LF</sub> = 32,768 kHz, C <sub>L,eff</sub> = 12 pF			200		
C <sub>L,eff</sub>	Integrated effective load capacitance, LF mode <sup>(3)</sup>	XTS = 0		XCAPx = 0		1	pF
				XCAPx = 1		5.5	
				XCAPx = 2		8.5	
				XCAPx = 3		11	
Duty Cycle	LF mode	XTS = 0, Measured at P1.4/ACLK, f <sub>LFXT1,LF</sub> = 32,768 Hz	2.2 V/3 V	30	50	70	%
f <sub>Fault,LF</sub>	Oscillator fault frequency threshold, LF mode <sup>(4)</sup>	XTS = 0, LFXT1Sx = 3 <sup>(5)</sup>	2.2 V/3 V	10		10,000	Hz

- (1) To improve EMI on the LFXT1 oscillator the following guidelines should be observed:
  - (a) Keep as short of a trace as possible between the device and the crystal.
  - (b) Design a good ground plane around the oscillator pins.
  - (c) Prevent crosstalk from other clock or data lines into oscillator pins XIN and XOUT.
  - (d) Avoid running PCB traces underneath or adjacent to the XIN and XOUT pins.
  - (e) Use assembly materials and praxis to avoid any parasitic load on the oscillator XIN and XOUT pins.
  - (f) If conformal coating is used, ensure that it does not induce capacitive/resistive leakage between the oscillator pins.
  - (g) Do not route the XOUT line to the JTAG header to support the serial programming adapter as shown in other documentation. This signal is no longer required for the serial programming adapter.
- (2) LFXT1 in 32-KHz mode is guaranteed to function only between –55°C to 105°C. This module is known to fail above 110°C. For further info contact TI support.
- (3) Includes parasitic bond and package capacitance (approximately 2 pF per pin). Since the PCB adds additional capacitance it is recommended to verify the correct load by measuring the ACLK frequency. For a correct setup the effective load capacitance should always match the specification of the used crystal.
- (4) Frequencies below the MIN specification set the fault flag, frequencies above the MAX specification do not set the fault flag. Frequencies in between might set the flag.
- (5) Measured with logic-level input frequency, but also applies to operation with crystals.

## Internal Very-Low-Power, Low-Frequency Oscillator (VLO) – Electrical Characteristics

over recommended ranges of supply voltage and operating free-air temperature (unless otherwise noted)

PARAMETER		TEST CONDITIONS	T <sub>A</sub>	V <sub>CC</sub>	MIN	TYP	MAX	UNIT
f <sub>VLO</sub>	VLO frequency		–55°C to 85°C	2.2 V/3 V	4	12	20	kHz
			150°C	2.2 V/3 V			22	
df <sub>VLO</sub> /dT	VLO frequency temperature drift	See <sup>(1)</sup>		2.2 V/3 V		0.5	0.8	%/°C
df <sub>VLO</sub> /dV <sub>CC</sub>	VLO frequency supply voltage drift	See <sup>(2)</sup>	25°C	1.8 V – 3.6V		4		%/V

- (1) Calculated using the box method:  
S Version: (MAX(–55 to 150°C) – MIN(–55 to 150°C))/MIN(–55 to 150°C)/(150°C – (–55°C))
- (2) Calculated using the box method: (MAX(1.8 V to 3.6 V) – MIN(1.8V to 3.6 V))/MIN(1.8 V to 3.6 V)/(3.6 V – 1.8 V)

**Crystal Oscillator (LFXT1) High Frequency Modes – Electrical Characteristics<sup>(1)</sup>**

over recommended ranges of supply voltage and operating free-air temperature (unless otherwise noted)

PARAMETER		TEST CONDITIONS	V <sub>CC</sub>	MIN	TYP	MAX	UNIT
f <sub>LFXT1,HF0</sub>	LFXT1 oscillator crystal frequency, HF mode 0	XTS = 1, LFXT1Sx = 0	1.8 V to 3.6 V	0.4		1	MHz
f <sub>LFXT1,HF1</sub>	LFXT1 oscillator crystal frequency, HF mode 1	XTS = 1, LFXT1Sx = 1	1.8 V to 3.6 V	1		4	MHz
f <sub>LFXT1,HF2</sub>	LFXT1 oscillator crystal frequency, HF mode 2	XTS = 1, LFXT1Sx = 2	1.8 V to 3.6 V	2		10	MHz
			2.2 V to 3.6 V	2		12	
			3 V to 3.6 V	2		16	
f <sub>LFXT1,HF,logic</sub>	LFXT1 oscillator logic-level square-wave input frequency, HF mode	XTS = 1, LFXT1Sx = 3	1.8 V to 3.6 V	0.4		10	MHz
			2.2 V to 3.6 V	0.4		12	
			3 V to 3.6 V	0.4		16	
O <sub>AHF</sub>	Oscillation allowance for HF crystals (see Figure 24 and Figure 25)	XTS = 0, LFXT1Sx = 0; f <sub>LFXT1,HF</sub> = 1 MHz, C <sub>L,eff</sub> = 15 pF			2700		Ω
		XTS = 0, LFXT1Sx = 1 f <sub>LFXT1,HF</sub> = 4 MHz, C <sub>L,eff</sub> = 15 pF			800		
		XTS = 0, LFXT1Sx = 2 f <sub>LFXT1,HF</sub> = 16 MHz, C <sub>L,eff</sub> = 15 pF			300		
C <sub>L,eff</sub>	Integrated effective load capacitance, HF mode <sup>(2)</sup>	XTS = 1 <sup>(3)</sup>			1		pF
Duty Cycle	HF mode	XTS = 1, Measured at P1.4/ACLK, f <sub>LFXT1,HF</sub> = 10 MHz	3 V	40	50	60	%
		XTS = 1, Measured at P1.4/ACLK, f <sub>LFXT1,HF</sub> = 16 MHz		40	50	60	
f <sub>Fault,HF</sub>	Oscillator fault frequency, HF mode <sup>(4)</sup>	XTS = 1, LFXT1Sx = 3 <sup>(5)</sup>	2.2 V/3 V	30		300	kHz

- (1) To improve EMI on the LFXT1 oscillator the following guidelines should be observed:
  - (a) Keep as short of a trace as possible between the device and the crystal.
  - (b) Design a good ground plane around the oscillator pins.
  - (c) Prevent crosstalk from other clock or data lines into oscillator pins XIN and XOUT.
  - (d) Avoid running PCB traces underneath or adjacent to the XIN and XOUT pins.
  - (e) Use assembly materials and praxis to avoid any parasitic load on the oscillator XIN and XOUT pins.
  - (f) If conformal coating is used, ensure that it does not induce capacitive/resistive leakage between the oscillator pins.
  - (g) Do not route the XOUT line to the JTAG header to support the serial programming adapter as shown in other documentation. This signal is no longer required for the serial programming adapter.
- (2) Includes parasitic bond and package capacitance (approximately 2 pF per pin). Since the PCB adds additional capacitance it is recommended to verify the correct load by measuring the ACLK frequency. For a correct setup the effective load capacitance should always match the specification of the used crystal.
- (3) Requires external capacitors at both terminals. Values are specified by crystal manufacturers.
- (4) Frequencies below the MIN specification set the fault flag, frequencies above the MAX specification do not set the fault flag. Frequencies in between might set the flag.
- (5) Measured with logic-level input frequency, but also applies to operation with crystals

Typical Characteristics – LFXT1 Oscillator in HF Mode (XTS = 1)

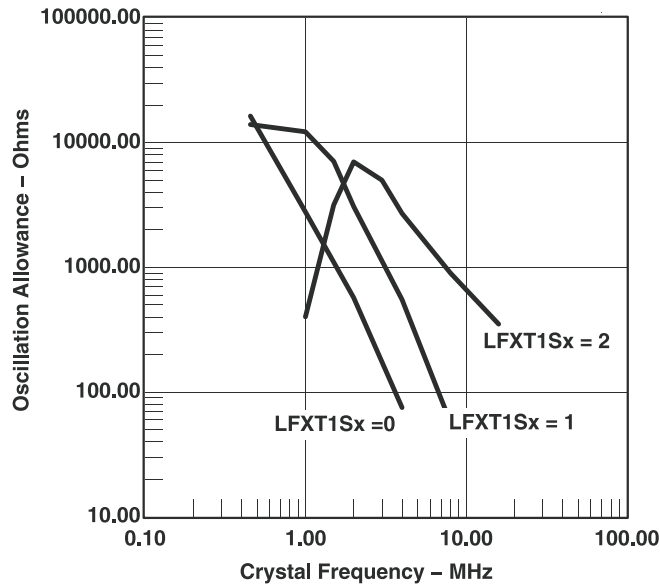

Figure 24. Oscillation Allowance vs Crystal Frequency,  $C_{L,eff} = 15 \text{ pF}$ ,  $T_A = 25^\circ\text{C}$

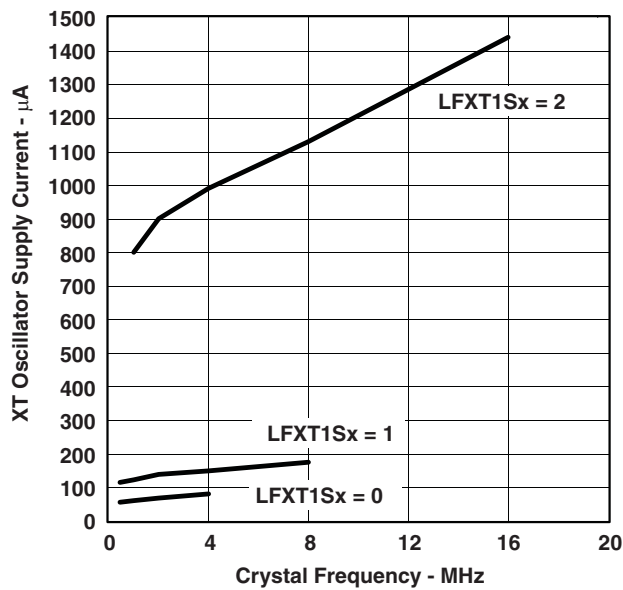

Figure 25. XT Oscillator Supply Current vs Crystal Frequency,  $C_{L,eff} = 15 \text{ pF}$ ,  $T_A = 25^\circ\text{C}$

## Crystal Oscillator (XT2) – Electrical Characteristics<sup>(1)</sup>

over recommended ranges of supply voltage and operating free-air temperature (unless otherwise noted)

PARAMETER		TEST CONDITIONS	V <sub>CC</sub>	MIN	TYP	MAX	UNIT
f <sub>XT2</sub>	XT2 oscillator crystal frequency, mode 0	XT2Sx = 0	1.8 V to 3.6 V	0.4		0.9	MHz
f <sub>XT2</sub>	XT2 oscillator crystal frequency, mode 1	XT2Sx = 1	1.8 V to 3.6 V	1		4	MHz
f <sub>XT2</sub>	XT2 oscillator crystal frequency, mode 2	XT2Sx = 2	1.8 V to 3.6 V	2		10	MHz
			2.2 V to 3.6 V	2		12	
			3 V to 3.6 V	2		16	
f <sub>XT2</sub>	XT2 oscillator logic-level square-wave input frequency,	XT2Sx = 3	1.8 V to 3.6 V	0.4		10	MHz
			2.2 V to 3.6 V	0.4		12	
			3 V to 3.6 V	0.4		16	
OA	Oscillation allowance (see <a href="#">Figure 26</a> and <a href="#">Figure 27</a> )	XT2Sx = 0, f <sub>XT2</sub> = 1 MHz; C <sub>L,eff</sub> = 15 pF			2700		Ω
		XT2Sx = 1, f <sub>XT2</sub> = 4MHz; C <sub>L,eff</sub> = 15 pF			800		
		XT2Sx = 2, f <sub>XT1, HF</sub> = 16 MHz; C <sub>L,eff</sub> = 15 pF			300		
C <sub>L,eff</sub>	Integrated effective load capacitance, HF mode <sup>(2)</sup>	See <sup>(3)</sup>			1		pF
Duty Cycle	HF mode	Measured at P1.4/SMCLK, f <sub>XT2</sub> = 10 MHz	2.2 V/3 V	40	50	60	%
		Measured at P1.4/SMCLK, f <sub>XT2</sub> = 16 MHz		40	50	60	
f <sub>Fault</sub>	Oscillator fault frequency, HF mode <sup>(4)</sup>	XT2Sx = 3 <sup>(5)</sup>	2.2 V/3 V	30		300	kHz

- (1) To improve EMI on the LFXT1 oscillator the following guidelines should be observed:
  - (a) Keep as short of a trace as possible between the device and the crystal.
  - (b) Design a good ground plane around the oscillator pins.
  - (c) Prevent crosstalk from other clock or data lines into oscillator pins XIN and XOUT.
  - (d) Avoid running PCB traces underneath or adjacent to the XIN and XOUT pins.
  - (e) Use assembly materials and praxis to avoid any parasitic load on the oscillator XIN and XOUT pins.
  - (f) If conformal coating is used, ensure that it does not induce capacitive/resistive leakage between the oscillator pins.
  - (g) Do not route the XOUT line to the JTAG header to support the serial programming adapter as shown in other documentation. This signal is no longer required for the serial programming adapter.
- (2) Includes parasitic bond and package capacitance (approximately 2 pF per pin). Since the PCB adds additional capacitance it is recommended to verify the correct load by measuring the ACLK frequency. For a correct setup the effective load capacitance should always match the specification of the used crystal.
- (3) Requires external capacitors at both terminals. Values are specified by crystal manufacturers.
- (4) Frequencies below the MIN specification set the fault flag, frequencies above the MAX specification do not set the fault flag. Frequencies in between might set the flag.
- (5) Measured with logic-level input frequency, but also applies to operation with crystals.

Typical Characteristics – XT2 Oscillator

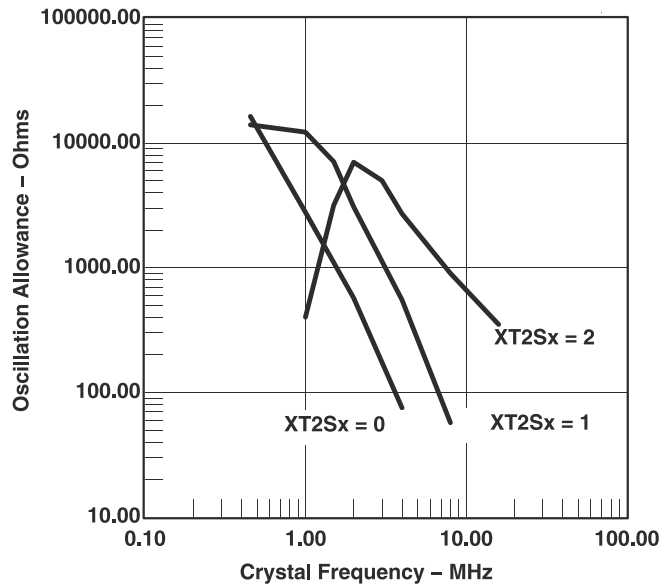

Figure 26. Oscillation Allowance vs Crystal Frequency,  $C_{L,eff} = 15 \text{ pF}$ ,  $T_A = 25^\circ\text{C}$

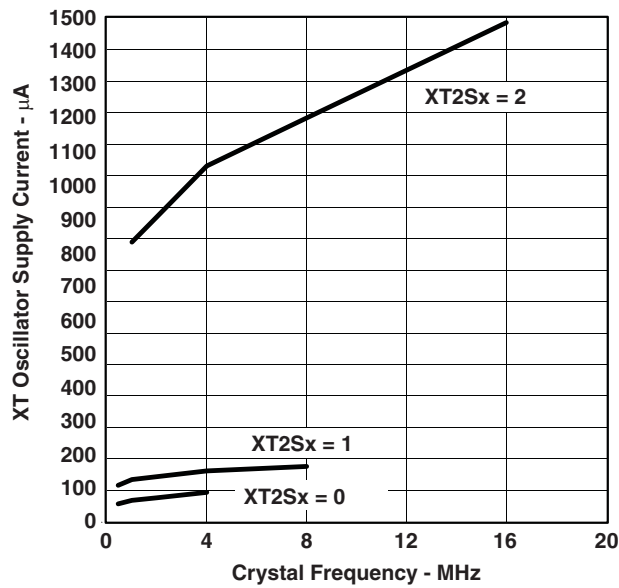

Figure 27. XT2 Oscillator Supply Current vs Crystal Frequency,  $C_{L,eff} = 15 \text{ pF}$ ,  $T_A = 25^\circ\text{C}$

### Timer\_A – Electrical Characteristics

over recommended ranges of supply voltage and operating free-air temperature (unless otherwise noted)

PARAMETER		TEST CONDITIONS	V <sub>CC</sub>	MIN	MAX	UNIT
f <sub>TA</sub>	Timer_A clock frequency	Internal: SMCLK, ACLK, External: TACLK, INCLK, Duty cycle = 50% ±10%	2.2 V		10	MHz
			3 V		16	
t <sub>TA,cap</sub>	Timer_A, capture timing	TA0, TA1, TA2	2.2 V/3 V	20		ns

### Timer\_B – Electrical Characteristics

over recommended ranges of supply voltage and operating free-air temperature (unless otherwise noted)

PARAMETER		TEST CONDITIONS	V <sub>CC</sub>	MIN	MAX	UNIT
f <sub>TB</sub>	Timer_B clock frequency	Internal: SMCLK, ACLK, External: TBCLK, Duty Cycle = 50% ±10%	2.2 V		10	MHz
			3 V		16	
t <sub>TB,cap</sub>	Timer_B, capture timing	TB0, TB1, TB2	2.2 V/3 V	20		ns

### USCI (UART Mode) – Electrical Characteristics

over recommended ranges of supply voltage and operating free-air temperature (unless otherwise noted)

PARAMETER		TEST CONDITIONS	V <sub>CC</sub>	MIN	TYP	MAX	UNIT
f <sub>USCI</sub>	USCI input clock frequency	Internal: SMCLK, ACLK, External: UCLK; Duty cycle = 50% ±10%				f <sub>SYSTEM</sub>	MHz
f <sub>BITCLK</sub>	BITCLK clock frequency (equals baud rate in Mbaud)		2.2 V/3 V			1	MHz
t <sub>r</sub>	UART receive deglitch time <sup>(1)</sup>		2.2 V	50	150	600	ns
			3 V	50	150	600	

(1) Pulses on the UART receive input (UCxRX) shorter than the UART receive deglitch time are suppressed. To ensure that pulses are correctly recognized, their width should exceed the maximum specification of the deglitch time.

### USCI (SPI Master Mode) – Electrical Characteristics

over recommended ranges of supply voltage and operating free-air temperature (unless otherwise noted)<sup>(1)</sup> (see [Figure 28](#) and [Figure 29](#))

PARAMETER		TEST CONDITIONS	V <sub>CC</sub>	MIN	MAX	UNIT
f <sub>USCI</sub>	USCI input clock frequency	SMCLK, ACLK, Duty cycle = 50% ±10%			f <sub>SYSTEM</sub>	MHz
t <sub>SU,MI</sub>	SOMI input data setup time		2.2 V	110		ns
			3 V	75		
t <sub>HD,MI</sub>	SOMI input data hold time		2.2 V	0		ns
			3 V	0		
t <sub>VALID,MO</sub>	SIMO output data valid time	UCLK edge to SIMO valid, C <sub>L</sub> = 20 pF	2.2 V		30	ns
			3 V		20	

(1)  $f_{UCxCLK} = 1/2t_{LO/HI}$  with  $t_{LO/HI} \geq \max(t_{VALID,MO}(USCI) + t_{SU,S}(Slave), t_{SU,MI}(USCI) + t_{VALID,SO}(Slave))$ .  
For the slave parameters  $t_{SU,S}(Slave)$  and  $t_{VALID,SO}(Slave)$ , see the SPI parameters of the attached slave.

### USCI (SPI Slave Mode) – Electrical Characteristics

over recommended ranges of supply voltage and operating free-air temperature (unless otherwise noted)<sup>(1)</sup> (see [Figure 30](#) and [Figure 31](#))

PARAMETER	TEST CONDITIONS	V <sub>CC</sub>	MIN	TYP	MAX	UNIT
t <sub>STE,LEAD</sub>	STE lead time, STE low to clock	2.2 V/3 V		50		ns
t <sub>STE,LAG</sub>	STE lag time, Last clock to STE high	2.2 V/3 V	10			ns
t <sub>STE,ACC</sub>	STE access time, STE low to SOMI data out	2.2 V/3 V		50		ns
t <sub>STE,DIS</sub>	STE disable time, STE high to SOMI high impedance	2.2 V/3 V		50		ns
t <sub>SU,SI</sub>	SIMO input data setup time	2.2 V	20			ns
		3 V	15			
t <sub>HD,SI</sub>	SIMO input data hold time	2.2 V	10			ns
		3 V	10			
t <sub>VALID,SO</sub>	SOMI output data valid time	2.2 V		75	110	ns
		3 V		50	75	

(1)  $f_{UCxCLK} = 1/2t_{LO/HI}$  with  $t_{LO/HI} \geq \max(t_{VALID,MO}(USCI) + t_{SU,SI}(Slave), t_{SU,MI}(USCI) + t_{VALID,SO}(Slave))$ .  
For the slave parameters  $t_{SU,SI}(Slave)$  and  $t_{VALID,SO}(Slave)$ , see the SPI parameters of the attached slave.

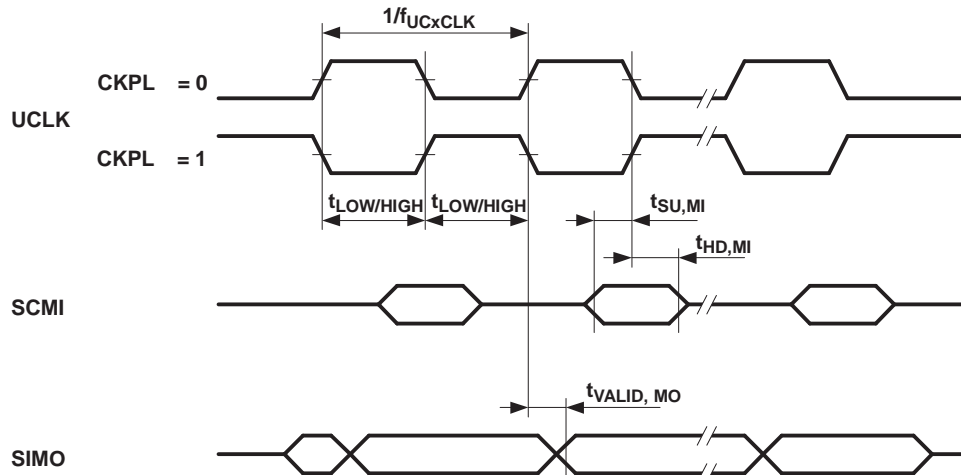

Figure 28. SPI Master Mode, CKPH = 0

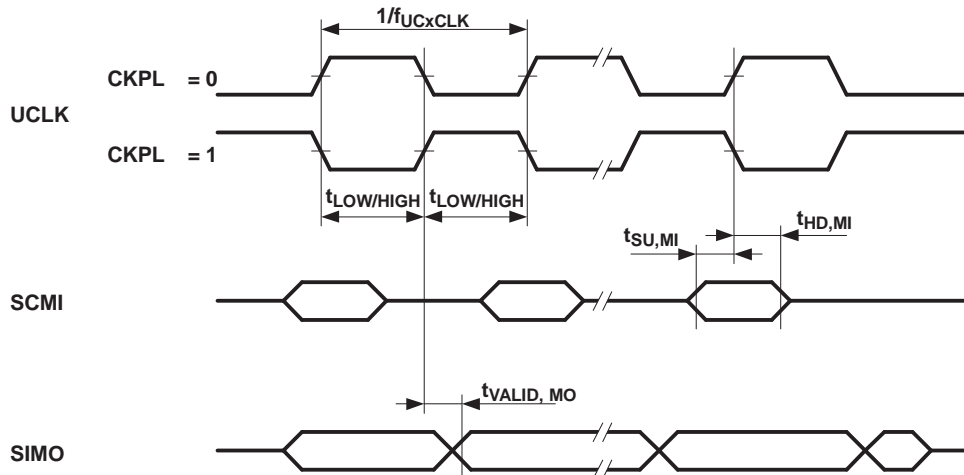

Figure 29. SPI Master Mode, CKPH = 1

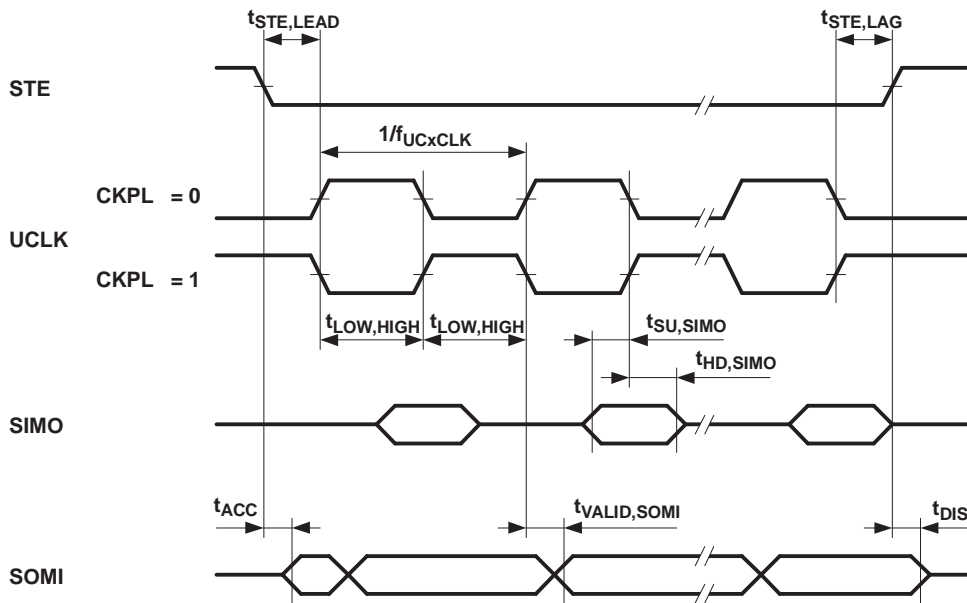

Figure 30. SPI Slave Mode, CKPH = 0

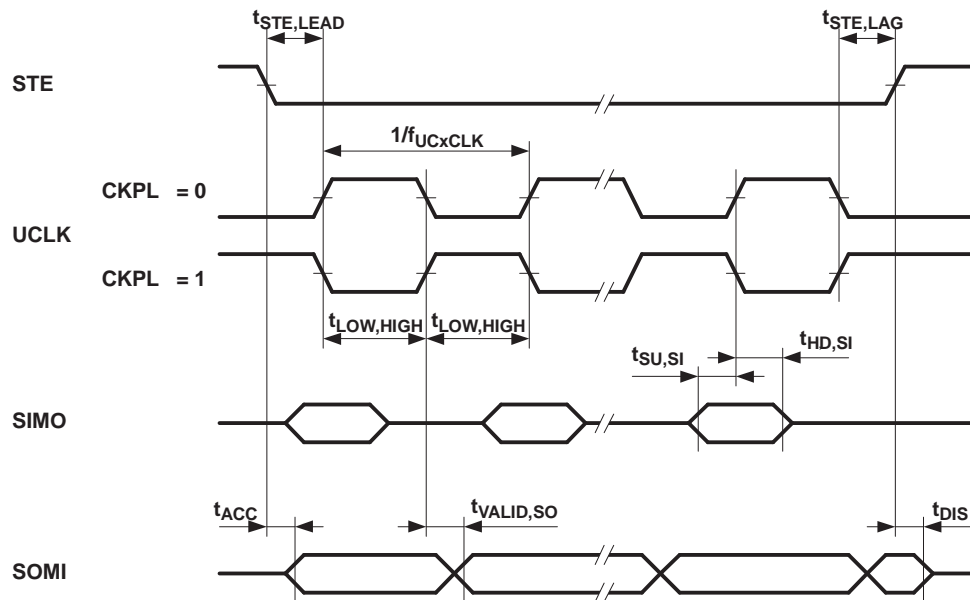
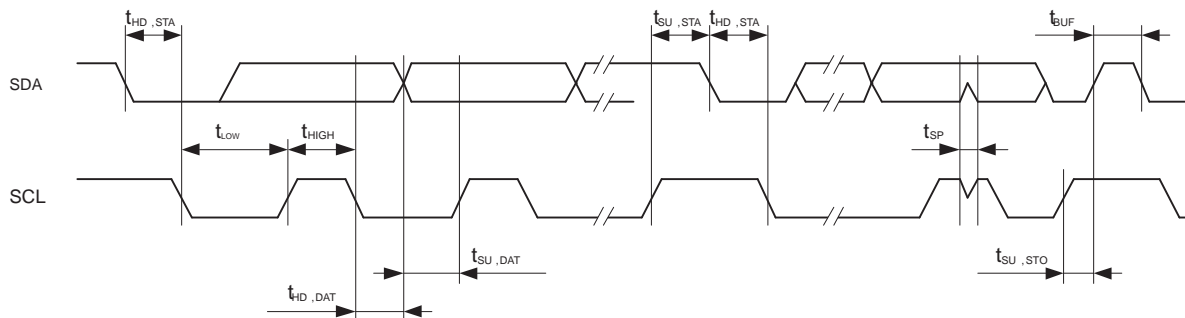

Figure 31. SPI Slave Mode, CKPH = 1

**USCI (I2C Mode) – Electrical Characteristics**

over recommended ranges of supply voltage and operating free-air temperature (unless otherwise noted) (see [Figure 32](#))

PARAMETER	TEST CONDITIONS	V <sub>CC</sub>	MIN	TYP	MAX	UNIT
f <sub>USCI</sub>	USCI input clock frequency		f <sub>SYSTEM</sub>			MHz
f <sub>SCL</sub>	SCL clock frequency	2.2 V/3 V	0		400	kHz
t <sub>HD,STA</sub>	Hold time (repeated) START	f <sub>SCL</sub> ≤ 100 kHz f <sub>SCL</sub> > 100 kHz	4.0			μs
t <sub>SU,STA</sub>	Set-up time for a repeated START	f <sub>SCL</sub> ≤ 100 kHz f <sub>SCL</sub> > 100 kHz	4.7			μs
t <sub>HD,DAT</sub>	Data hold time		0			ns
t <sub>SU,DAT</sub>	Data set-up time		250			ns
t <sub>SU,STO</sub>	Set-up time for STOP		4.0			μs
t <sub>SP</sub>	Pulse width of spikes suppressed by input filter	2.2 V	50	150	600	ns
		3 V	50	100	600	



**Figure 32. I2C Mode Timing**

## Comparator\_A+ – Electrical Characteristics<sup>(1)</sup>

over recommended ranges of supply voltage and operating free-air temperature (unless otherwise noted)

PARAMETER	TEST CONDITIONS	V <sub>CC</sub>	MIN	TYP	MAX	UNIT	
I <sub>(DD)</sub>	CAON = 1 CARSEL = 0 CAREF = 0	2.2 V		25	80	μA	
		3 V		45	96		
I <sub>(Refladder/Refdiode)</sub>	CAON = 1, CARSEL = 0, CAREF = 1/2/3 no load at P2 3/CA0/TA1 and P2.4/CA1/TA2	2.2 V/3 V		30	50	μA	
		3 V		45	71		
V <sub>(IC)</sub>	Common-mode input voltage	CAON = 1	2.2 V/3 V	0	V <sub>CC</sub> - 1	V	
V <sub>(Ref025)</sub>	Voltage at 0.25 V <sub>CC</sub> node/V <sub>CC</sub>	PCA0 = 1, CARSEL = 1, CAREF = 1, no load at P2.3/CA0/TA1 and P2.4/CA1/TA2	2.2 V/3 V	0.23	0.24	0.25	V
V <sub>(Ref050)</sub>	Voltage at 0.5 V <sub>CC</sub> node/V <sub>CC</sub>	PCA0 = 1, CARSEL = 1, CAREF = 2, no load at P2.3/CA0/TA1 and P2.4/CA1/TA2	2.2 V/3 V	0.47	0.48	0.5	V
V <sub>(RefVT)</sub>	See <a href="#">Figure 36</a> and <a href="#">Figure 37</a>	PCA0 = 1, CARSEL = 1, CAREF = 3, no load at P2.3/CA0/TA1 and P2.4/CA1/TA2, T <sub>A</sub> = 85°C	2.2 V	390	480	540	mV
			3 V	400	490	550	
V <sub>(offset)</sub>	Offset voltage	See <sup>(2)</sup>	2.2 V/3 V	-30		30	mV
V <sub>(hys)</sub>	Input hysteresis	CAON=1	2.2 V/3 V	0	0.7	1.4	mV
t <sub>(response)</sub>	Response time, low-to-high and high-to-low <sup>(3)</sup>	T <sub>A</sub> = 25°C, Overdrive 10 mV, Without filter: CAF = 0	2.2 V	80	165	300	ns
			3 V	70	120	240	
		T <sub>A</sub> = 25°C, Overdrive 10 mV, Without filter: CAF = 1	2.2 V	1.4	1.9	2.8	μs
			3 V	0.9	1.5	2.2	

- (1) The leakage current for the Comparator\_A+ terminals is identical to I<sub>ikg(Px.x)</sub> specification.
- (2) The input offset voltage can be cancelled by using the CAEX bit to invert the Comparator\_A+ inputs on successive measurements. The two successive measurements are then summed together.
- (3) The response time is measured at P2.2/CAOUT/TA0/CA4 with an input voltage step, with Comparator\_A+ already enabled (CAON = 1). If CAON is set at the same time, a settling time of up to 300 ns is added to the response time.

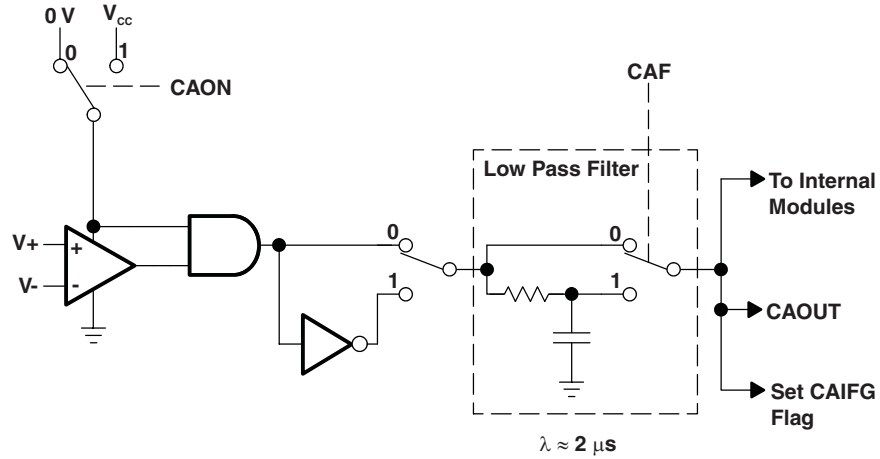

Figure 33. Block Diagram of Comparator\_A Module

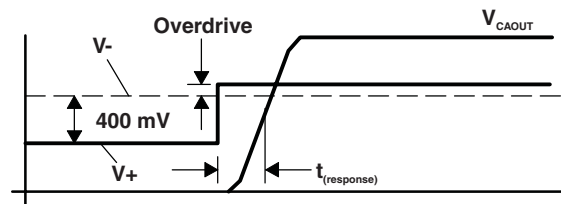

Figure 34. Overdrive Definition

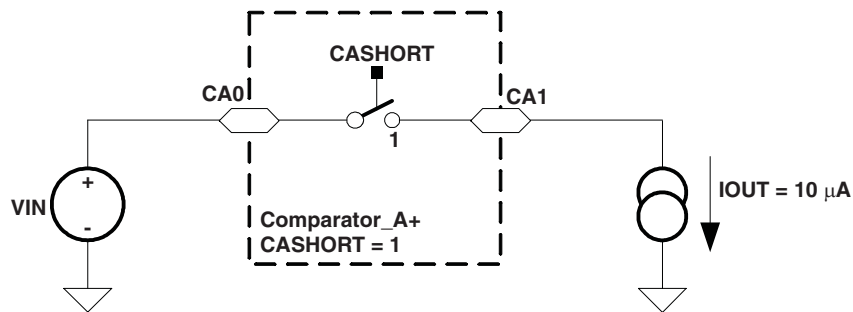

Figure 35. Comparator\_A+ Short Resistance Test Condition

Typical Characteristics – Comparator A+

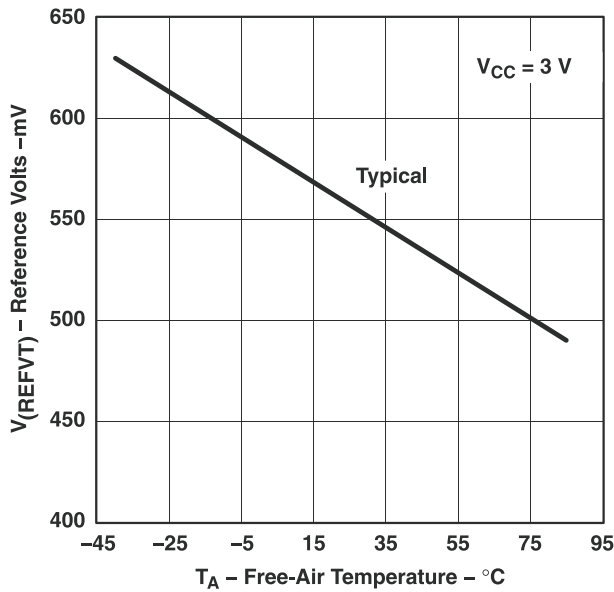

Figure 36.  $V_{(RefVT)}$  vs Temperature,  $V_{CC} = 3\text{ V}$

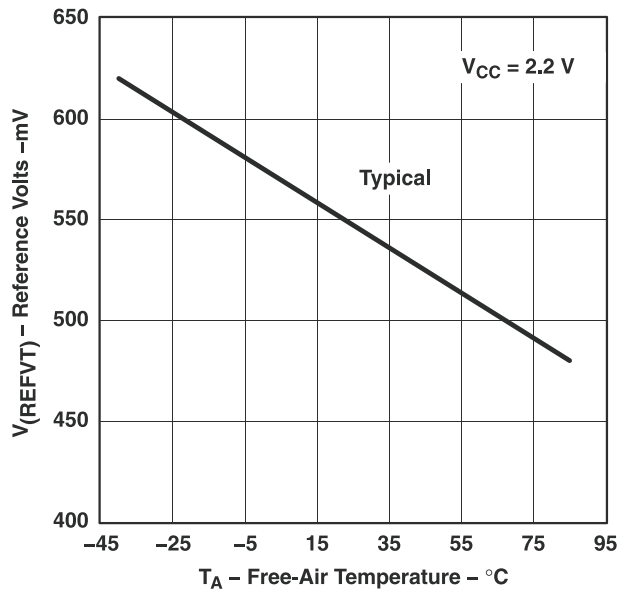

Figure 37.  $V_{(RefVT)}$  vs Temperature,  $V_{CC} = 2.2\text{ V}$

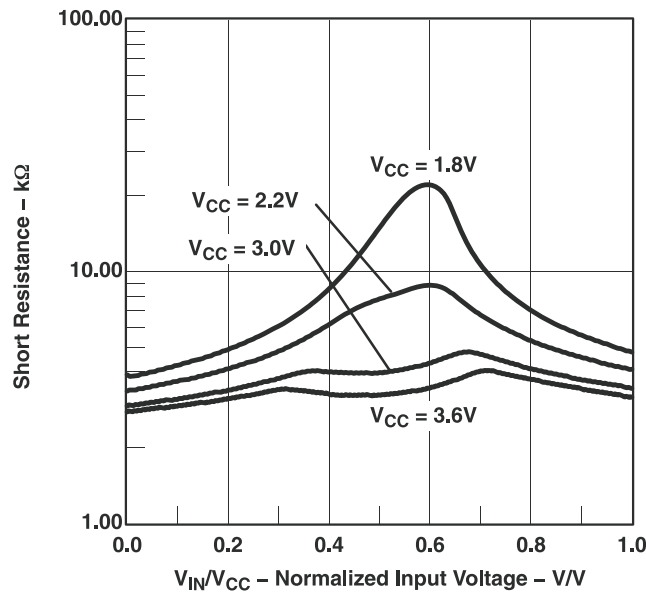

Figure 38. Short Resistance vs  $V_{IN}/V_{CC}$

## 12-Bit ADC Power-Supply and Input Range Conditions – Electrical Characteristics<sup>(1)</sup>

over recommended ranges of supply voltage and operating free-air temperature (unless otherwise noted)

PARAMETER		TEST CONDITIONS	V <sub>CC</sub>	MIN	TYP	MAX	UNIT
AV <sub>CC</sub>	Analog supply voltage range	AV <sub>CC</sub> and DV <sub>CC</sub> are connected together, AV <sub>SS</sub> and DV <sub>SS</sub> are connected together, V <sub>(AVSS)</sub> = V <sub>(DVSS)</sub> = 0 V		2.2		3.6	V
V <sub>(P6.x/Ax)</sub>	Analog input voltage range <sup>(2)</sup>	All P6.0/A0 to P6.7/A7 terminals. Analog inputs selected in ADC12MCTLx register and P6Sel.x = 1, 0 ≤ x ≤ 7, V <sub>(AVSS)</sub> ≤ VP6.x/Ax ≤ V <sub>(AVCC)</sub>		0		V <sub>AVCC</sub>	V
I <sub>ADC12</sub>	Operating supply current into AV <sub>CC</sub> terminal <sup>(3)</sup>	f <sub>ADC10CLK</sub> = 5 MHz, ADC12ON = 1, REFON = 0, SHT0 = 0, SHT1 = 0, ADC12DIV = 0	2.2 V		0.65	0.8	mA
			3 V		0.8	1	
I <sub>REF+</sub>	Reference supply current, into AV <sub>CC</sub> terminal <sup>(4)</sup>	f <sub>ADC12CLK</sub> = 5 MHz, ADC12ON = 0, REFON = 1, REF2_5V = 1	3 V		0.5	0.7	mA
			2.2 V		0.5	0.7	
				3 V			
C <sub>I</sub> <sup>(5)</sup>	Input capacitance	Only one terminal selected at a time, P6.x/Ax	2.2 V			40	pF
R <sub>I</sub> <sup>(5)</sup>	Input MUX ON resistance	0 V ≤ V <sub>Ax</sub> ≤ V <sub>AVCC</sub>	3 V			2000	Ω

- (1) The leakage current is defined in the leakage current table with P6.x/Ax parameter.
- (2) The analog input voltage range must be within the selected reference voltage range V<sub>R+</sub> to V<sub>R-</sub> for valid conversion results.
- (3) The internal reference supply current is not included in current consumption parameter I<sub>ADC12</sub>.
- (4) The internal reference current is supplied via terminal V<sub>CC</sub>. Consumption is independent of the ADC10ON control bit, unless a conversion is active. The REFON bit enables the built-in reference to settle before starting an A/D conversion.
- (5) Limits verified by design.

## 12-Bit ADC External Reference – Electrical Characteristics

over recommended ranges of supply voltage and operating free-air temperature (unless otherwise noted)

PARAMETER		TEST CONDITIONS	V <sub>CC</sub>	MIN	TYP	MAX	UNIT
V <sub>eREF+</sub>	Positive external reference voltage input	V <sub>eREF+</sub> > V <sub>REF-/VeREF-</sub> <sup>(1)</sup>		1.4		V <sub>AVCC</sub>	V
V <sub>REF-/VeREF+</sub>	Negative external reference voltage input	V <sub>eREF+</sub> > V <sub>REF-/VeREF-</sub> <sup>(2)</sup>		0		1.2	V
(V <sub>eREF+</sub> - V <sub>REF-/VeREF-</sub> )	Differential external reference voltage input	V <sub>eREF+</sub> > V <sub>REF-/VeREF-</sub> <sup>(3)</sup>		1.4		V <sub>AVCC</sub>	V
I <sub>VeREF+</sub>	Static input current	0 V ≤ V <sub>eREF+</sub> ≤ V <sub>AVCC</sub>	2.2 V/3 V			±1	μA
I <sub>VREF-/VeREF-</sub>	Static input current	0 V ≤ V <sub>eREF-</sub> ≤ V <sub>AVCC</sub>	2.2 V/3 V			±1	μA

- (1) The accuracy limits the minimum positive external reference voltage. Lower reference voltage levels may be applied with reduced accuracy requirements.
- (2) The accuracy limits the maximum negative external reference voltage. Higher reference voltage levels may be applied with reduced accuracy requirements.
- (3) The accuracy limits minimum external differential reference voltage. Lower differential reference voltage levels may be applied with reduced accuracy requirements.

### 12-Bit ADC Built-In Reference – Electrical Characteristics

over recommended ranges of supply voltage and operating free-air temperature (unless otherwise noted)

PARAMETER	TEST CONDITIONS	T <sub>A</sub>	V <sub>CC</sub>	MIN	TYP	MAX	UNIT
V <sub>REF+</sub>	REF2_5V = 1 (2.5 V) I <sub>VREF+</sub> max ≤ I <sub>VREF+</sub> ≤ I <sub>VREF+</sub> min	-55°C to 85°C	3 V	2.4	2.5	2.6	V
		150°C		2.37	2.5	2.64	
	REF2_5V = 1 (1.5 V) I <sub>VREF+</sub> max ≤ I <sub>VREF+</sub> ≤ I <sub>VREF+</sub> min	-55°C to 85°C	2.2 V/3 V	1.44	1.5	1.56	
		150°C		1.42	1.5	1.57	
AV <sub>CC(min)</sub>	REF2_5V = 0, I <sub>VREF+</sub> max ≤ I <sub>VREF+</sub> ≤ I <sub>VREF+</sub> min			2.2			V
	REF2_5V = 1, -0.5 mA ≤ I <sub>VREF+</sub> ≤ I <sub>VREF+</sub> min			2.8			
	REF2_5V = 1, -1 mA ≤ I <sub>VREF+</sub> ≤ I <sub>VREF+</sub> min			2.9			
I <sub>VREF+</sub>	Load current out of V <sub>REF+</sub> terminal		2.2 V	0.01		-0.5	mA
			3 V	0.01		-1	
I <sub>L(VREF+)</sub> <sup>(1)</sup>	Load current regulation, V <sub>REF+</sub> terminal	I <sub>VREF+</sub> = 500 μA ± 100 μA, Analog input voltage V <sub>AX</sub> ≠ 0.75 V, REF2_5V = 0	2.2 V			±2	LSB
			3 V			±2	
			3 V			±2	
I <sub>DL(VREF+)</sub> <sup>(2)</sup>	Load current regulation, V <sub>REF+</sub> terminal	I <sub>VREF+</sub> = 100 μA → 900 μA, C <sub>VREF+</sub> = 5 μF, at ≠ 0.5 V <sub>REF+</sub> , Error of conversion result ≤ 1 LSB	3 V			20	ns
C <sub>VREF+</sub>	Capacitance at pin V <sub>REF+</sub> <sup>(3)</sup>	REFON = 1, 0 mA ≤ I <sub>VREF+</sub> ≤ I <sub>VREF+</sub> max	2.2 V/3 V	5	10		μF
T <sub>REF+</sub> <sup>(1)</sup>	Temperature coefficient of built-in reference	I <sub>VREF+</sub> is a constant in the range of 0 mA ≤ I <sub>VREF+</sub> ≤ 1 mA	2.2 V/3 V			±100	ppm/°C
t <sub>REFON</sub> <sup>(1)</sup>	Settling time of internal reference voltage <sup>(4)</sup> (See Figure 39)	I <sub>VREF+</sub> = 0.5 mA, C <sub>VREF+</sub> = 10 μF, V <sub>REF+</sub> = 1.5 V, V <sub>AVCC</sub> = 2.2 V				17	ms

- (1) Limits characterized
- (2) Limits verified by design
- (3) The internal buffer operational amplifier and the accuracy specifications require an external capacitor. All INL and DNL tests use two capacitors between pins V<sub>REF+</sub> and AV<sub>SS</sub> and V<sub>REF-</sub>/V<sub>REF-</sub> and AV<sub>SS</sub>: 10 μF tantalum and 100 nF ceramic.
- (4) The condition is that the error in a conversion started after t<sub>REFON</sub> or t<sub>RefBuf</sub> is less than ±0.5 LSB.

### Typical Characteristics – ADC12

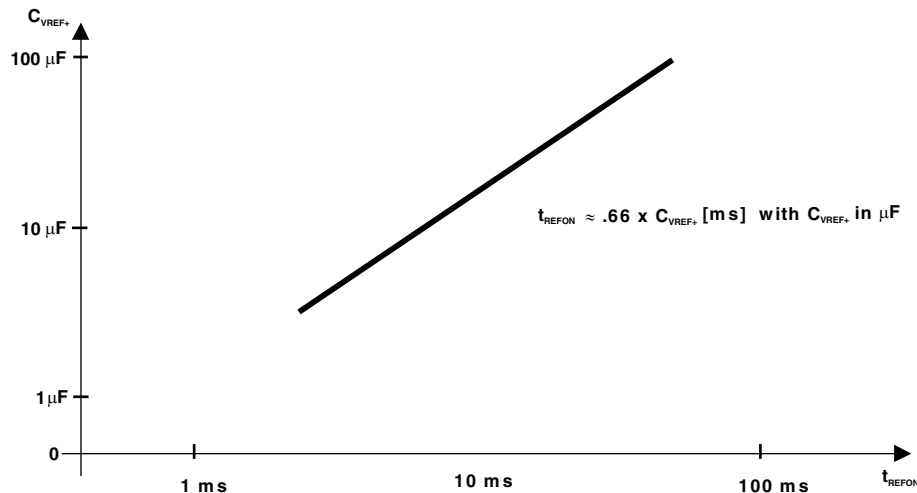

Figure 39. Typical Settling Time of Internal Reference t<sub>REFON</sub> vs External Capacitor on V<sub>REF+</sub>

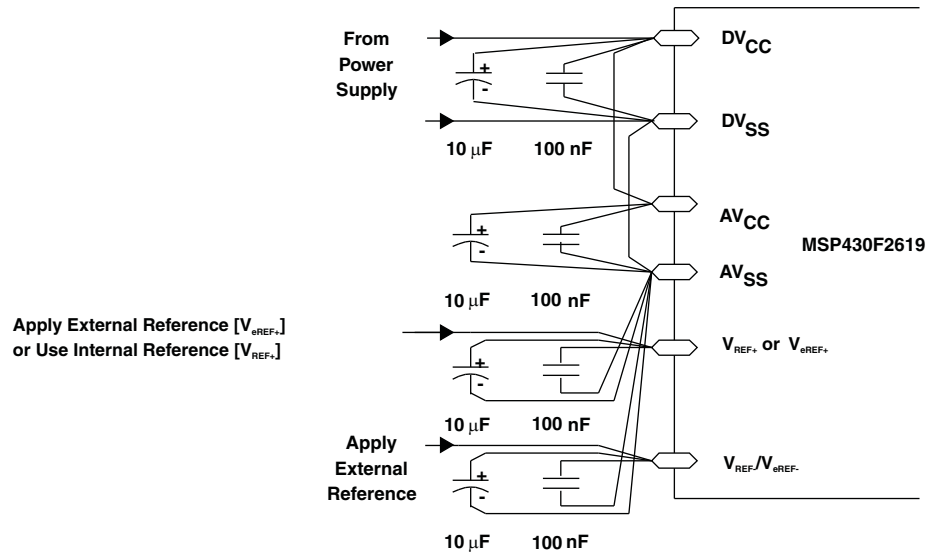

Figure 40. Supply Voltage and Reference Voltage Design V<sub>REF-/V<sub>eREF-</sub></sub> External Supply

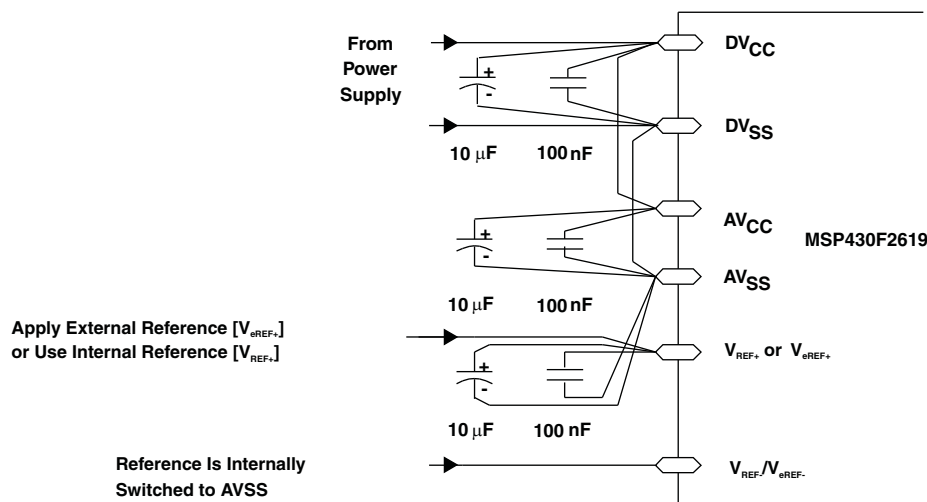

Figure 41. Supply Voltage and Reference Voltage Design V<sub>REF-/V<sub>eREF-</sub></sub> = AV<sub>SS</sub>, Internally Connected

## 12-Bit ADC Timing Parameters – Electrical Characteristics

over recommended ranges of supply voltage and operating free-air temperature (unless otherwise noted)

PARAMETER		TEST CONDITIONS	V <sub>CC</sub>	MIN	TYP	MAX	UNIT
f <sub>ADC12CLK</sub>	ADC12 input clock frequency	For specified performance of ADC12 linearity parameters	2.2 V/3 V	0.45	5	6.3	MHz
f <sub>ADC12OSC</sub>	ADC12 built-in oscillator frequency	ADC12DIV = 0, f <sub>ADC12CLK</sub> = f <sub>ADC12OSC</sub>	2.2 V/3 V	3.7	5	6.3	MHz
t <sub>CONVERT</sub>	Conversion time	ADC12 built-in oscillator, C <sub>VREF+</sub> ≥ 5 μF, f <sub>ADC12OSC</sub> = 3.7 MHz to 6.3 MHz	2.2 V/3 V	2.06		3.51	μs
		External f <sub>ADC12CLK</sub> from ACLK, MCLK, or SMCLK: ADC12SSEL ≠ 0			13 x ADC12DIV x 1/f <sub>ADC12CLK</sub>		
t <sub>ADC12ON</sub> <sup>(1)</sup>	Turn-on settling time of the ADC	See <sup>(2)</sup>				100	ns
t <sub>Sample</sub> <sup>(1)</sup>	Sampling time	RS = 400 Ω, RI = 1000 Ω, CI = 30 pF, τ = [RS + RI] x CI <sup>(3)</sup>	3 V	1220			ns
			2.2 V	1400			

(1) Limits verified by design

(2) The condition is that the error in a conversion started after t<sub>ADC12ON</sub> is less than ±0.5 LSB. The reference and input signal are already settled.

(3) Approximately ten Tau (τ) are needed to get an error of less than ±0.5 LSB: t<sub>Sample</sub> = ln(2<sup>n+1</sup>) x (RS + RI) x CI + 800 ns where n = ADC resolution = 12, RS = external source resistance.

## 12-Bit ADC Linearity Parameters – Electrical Characteristics

over recommended ranges of supply voltage and operating free-air temperature (unless otherwise noted)

PARAMETER		TEST CONDITIONS	V <sub>CC</sub>	MIN	TYP	MAX	UNIT
E <sub>I</sub>	Integral linearity error	1.4 V ≤ (V <sub>eREF+</sub> - V <sub>REF</sub> /V <sub>eREF-</sub> ) min ≤ 1.6 V	2.2 V/3 V			±2	LSB
		1.6 V < (V <sub>eREF+</sub> - V <sub>REF</sub> /V <sub>eREF-</sub> ) min ≤ V <sub>AVCC</sub>				±1.7	
E <sub>D</sub>	Differential linearity error	(V <sub>eREF+</sub> - V <sub>REF</sub> /V <sub>eREF-</sub> ) min ≤ (V <sub>eREF+</sub> - V <sub>REF</sub> /V <sub>eREF-</sub> ), C <sub>VREF+</sub> = 10 μF (tantalum) and 100 nF (ceramic)	2.2 V/3 V			±1	LSB
E <sub>O</sub>	Offset error	(V <sub>eREF+</sub> - V <sub>REF</sub> /V <sub>eREF-</sub> ) min ≤ (V <sub>eREF+</sub> - V <sub>REF</sub> /V <sub>eREF-</sub> ), Internal impedance of source R <sub>S</sub> < 100 Ω, C <sub>VREF+</sub> = 10 μF (tantalum) and 100 nF (ceramic)	2.2 V/3 V		±2	±4	LSB
E <sub>G</sub>	Gain error	(V <sub>eREF+</sub> - V <sub>REF</sub> /V <sub>eREF-</sub> ) min ≤ (V <sub>eREF+</sub> - V <sub>REF</sub> /V <sub>eREF-</sub> ), C <sub>VREF+</sub> = 10 μF (tantalum) and 100 nF (ceramic)	2.2 V/3 V		±1.1	±2	LSB
E <sub>T</sub>	Total unadjusted error	(V <sub>eREF+</sub> - V <sub>REF</sub> /V <sub>eREF-</sub> ) min ≤ (V <sub>eREF+</sub> - V <sub>REF</sub> /V <sub>eREF-</sub> ), C <sub>VREF+</sub> = 10 μF (tantalum) and 100 nF (ceramic)	2.2 V/3 V		±2	±5	LSB

## 12-Bit ADC Temperature Sensor and Built-In $V_{MID}$ – Electrical Characteristics

over recommended ranges of supply voltage and operating free-air temperature (unless otherwise noted)

PARAMETER		TEST CONDITIONS	$V_{CC}$	MIN	TYP	MAX	UNIT
$I_{SENSOR}$	Operating supply current into $AV_{CC}$ terminal <sup>(1)</sup>	REFON = 0, INCH = 0Ah, ADC12ON = 1, $T_A = 25^\circ\text{C}$	2.2 V		40	120	$\mu\text{A}$
			3 V		60	160	
$V_{Sensor}^{(2)}$	Sensor output voltage <sup>(3)</sup>	ADC12ON = 1, INCH = 0Ah, $T_A = 0^\circ\text{C}$	2.2 V/3 V		986		mV
$TC_{SENSOR}^{(2)}$		ADC12ON = 1, INCH = 0Ah	2.2 V/3 V		3.55		mV/ $^\circ\text{C}$
$t_{Sensor(sample)}^{(2)}$	Sample time required if channel 10 is selected <sup>(4)</sup>	ADC12ON = 1, INCH = 0Ah, Error of conversion result $\leq 1$ LSB	2.2 V/3 V	30			$\mu\text{s}$
$I_{VMID}$	Current into divider at channel 11 <sup>(5)</sup>	ADC12ON = 1, INCH = 0Bh	2.2 V			NA	$\mu\text{A}$
			3 V			NA	
$V_{MID}$	$AV_{CC}$ divider at channel 11	ADC12ON = 1, INCH = 0Bh, $V_{MID}$ is $\neq 0.5 \times V_{AVCC}$	2.2 V		1.1	$1.1 \pm 0.04$	V
			3 V		1.5	$1.5 \pm 0.04$	
$t_{VMID(sample)}$	Sample time required if channel 11 is selected <sup>(6)</sup>	ADC12ON = 1, INCH = 0Bh, Error of conversion result $\leq 1$ LSB	2.2 V	1400			ns
			3 V	1220			

- (1) The sensor current  $I_{SENSOR}$  is consumed if (ADC12ON = 1 and REFON = 1) or (ADC12ON = 1 and INCH = 0Ah and sample signal is high). When REFON = 1,  $I_{SENSOR}$  is included in  $I_{REF+}$ . When REFON = 0,  $I_{SENSOR}$  applies during conversion of the temperature sensor input (INCH = 0Ah).
- (2) Limits characterized
- (3) The temperature sensor offset can be as much as  $\pm 20^\circ\text{C}$ . A single-point calibration is recommended to minimize the offset error of the built-in temperature sensor.
- (4) The typical equivalent impedance of the sensor is 51 k $\Omega$ . The sample time required includes the sensor-on time  $t_{SENSOR(on)}$ .
- (5) No additional current is needed. The  $V_{MID}$  is used during sampling.
- (6) The on-time  $t_{VMID(on)}$  is included in the sampling time  $t_{VMID(sample)}$ ; no additional on time is needed.

## 12-Bit DAC Supply Specifications – Electrical Characteristics

over recommended ranges of supply voltage and operating free-air temperature (unless otherwise noted)

PARAMETER		TEST CONDITIONS	$T_A$	$V_{CC}$	MIN	TYP	MAX	UNIT
$AV_{CC}$	Supply voltage range	$AV_{CC} = DV_{CC}$ , $AV_{SS} = DV_{SS} = 0$ V			2.2		3.6	V
$I_{DD}$	Supply current, single DAC channel <sup>(1) (2)</sup>	DAC12AMPx = 2, DAC12IR = 0, DAC12_xDAT = 0x0800	-55 $^\circ\text{C}$ to 85 $^\circ\text{C}$	2.2 V/3 V		50	110	$\mu\text{A}$
			105 $^\circ\text{C}$			69	150	
		DAC12AMPx = 2, DAC12IR = 1, DAC12_xDAT = 0x0800, $V_{eREF+} = V_{REF+} = AV_{CC}$				50	130	
		DAC12AMPx = 5, DAC12IR = 1, DAC12_xDAT = 0x0800, $V_{eREF+} = V_{REF+} = AV_{CC}$				200	440	
		DAC12AMPx = 7, DAC12IR = 1, DAC12_xDAT = 0x0800, $V_{eREF+} = V_{REF+} = AV_{CC}$				700	1500	
PSSR	Power-supply rejection ratio <sup>(3)(4)</sup>	DAC12_xDAT = 800h, $V_{REF} = 1.5$ V, $\Delta AV_{CC} = 100$ mV		2.2 V/3 V		70		dB
							70	
		DAC12_xDAT = 800h, $V_{REF} = 1.5$ V or 2.5 V, $\Delta AV_{CC} = 100$ mV						

- (1) No load at the output pin, DAC12\_0 or DAC12\_1, assuming that the control bits for the shared pins are set properly.
- (2) Current into reference terminals not included. If DAC12IR = 1 current flows through the input divider; see Reference Input specifications.
- (3)  $PSRR = 20 \times \log\{\Delta AV_{CC}/\Delta V_{DAC12\_xOUT}\}$
- (4)  $V_{REF}$  is applied externally. The internal reference is not used.

### 12-Bit DAC Linearity Parameters – Electrical Characteristics

over recommended ranges of supply voltage and operating free-air temperature (unless otherwise noted)

PARAMETER		TEST CONDITIONS	V <sub>CC</sub>	MIN	TYP	MAX	UNIT
Resolution		12-bit monotonic		12			bits
INL	Integral nonlinearity <sup>(1)</sup>	V <sub>REF</sub> = 1.5 V DAC12AMPx = 7, DAC12IR = 1	2.2 V/3 V		±2	±8	LSB
		V <sub>REF</sub> = 2.5 V DAC12AMPx = 7, DAC12IR = 1			±2	±8	
DNL	Differential nonlinearity <sup>(1)</sup>	V <sub>REF</sub> = 1.5 V DAC12AMPx = 7, DAC12IR = 1	2.2 V/3 V		±0.4	±1	LSB
		V <sub>REF</sub> = 2.5 V DAC12AMPx = 7, DAC12IR = 1			±0.4	±1	
E <sub>O</sub>	Offset voltage without calibration <sup>(1)(2)</sup>	V <sub>REF</sub> = 1.5 V DAC12AMPx = 7, DAC12IR = 1	2.2 V/3 V		±21		LSB
		V <sub>REF</sub> = 2.5 V DAC12AMPx = 7, DAC12IR = 1			±21		
	Offset voltage with calibration <sup>(1)(2)</sup>	V <sub>REF</sub> = 1.5 V DAC12AMPx = 7, DAC12IR = 1			±3.5		
		V <sub>REF</sub> = 2.5 V DAC12AMPx = 7, DAC12IR = 1			±3.5		
dE <sub>O</sub> /dT	Offset error temperature coefficient <sup>(1)</sup>			30		µV/°C	
E <sub>G</sub>	Gain error <sup>(1)</sup>	V <sub>REF</sub> = 1.5 V	2.2 V/3 V		±3.5		LSB
		V <sub>REF</sub> = 2.5 V			±3.5		
dE <sub>G</sub> /dT	Gain temperature coefficient <sup>(1)</sup>			10		ppm of FSR/°C	
t <sub>Offset_Cal</sub>	Time for offset calibration <sup>(3)</sup>	DAC12AMPx = 2	2.2 V/3 V		100		LSB
		DAC12AMPx = 3, 5			32		
		DAC12AMPx = 4, 6, 7			6		

- (1) Parameters calculated from the best-fit curve from 0x0A to 0xFFF. The best-fit curve method is used to deliver coefficients “a” and “b” of the first-order equation:  $y = a + b \times x$ .  $V_{DAC12\_xOUT} = E_O + (1 + E_G) \times (V_{REF+}/4095) \times DAC12\_xDAT$ , DAC12IR = 1.
- (2) The offset calibration works on the output operational amplifier. Offset calibration is triggered setting bit DAC12CALON.
- (3) The offset calibration can be done if DAC12AMPx = {2, 3, 4, 5, 6, 7}. The output operational amplifier is switched off with DAC12AMPx={0, 1}. The DAC12 module should be configured prior to initiating calibration. Port activity during calibration may affect accuracy and is not recommended.

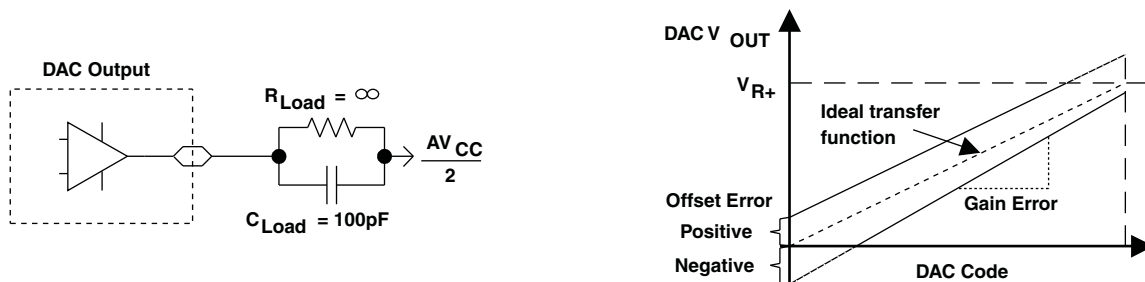

Figure 42. Linearity Test Load Conditions and Gain/Offset Definition

Typical Characteristics - 12-Bit DAC Linearity Specifications

Figure 43. TYPICAL INL ERROR  
VS  
DIGITAL INPUT DATA

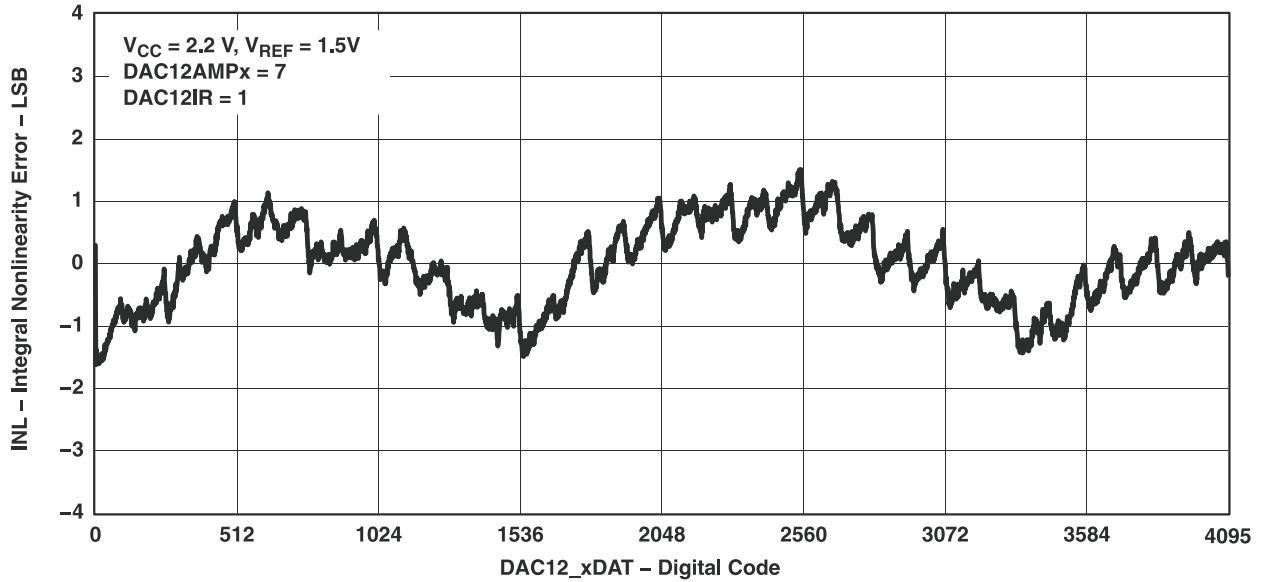

Figure 44.

Figure 45. TYPICAL DNL ERROR  
VS  
DIGITAL INPUT DATA

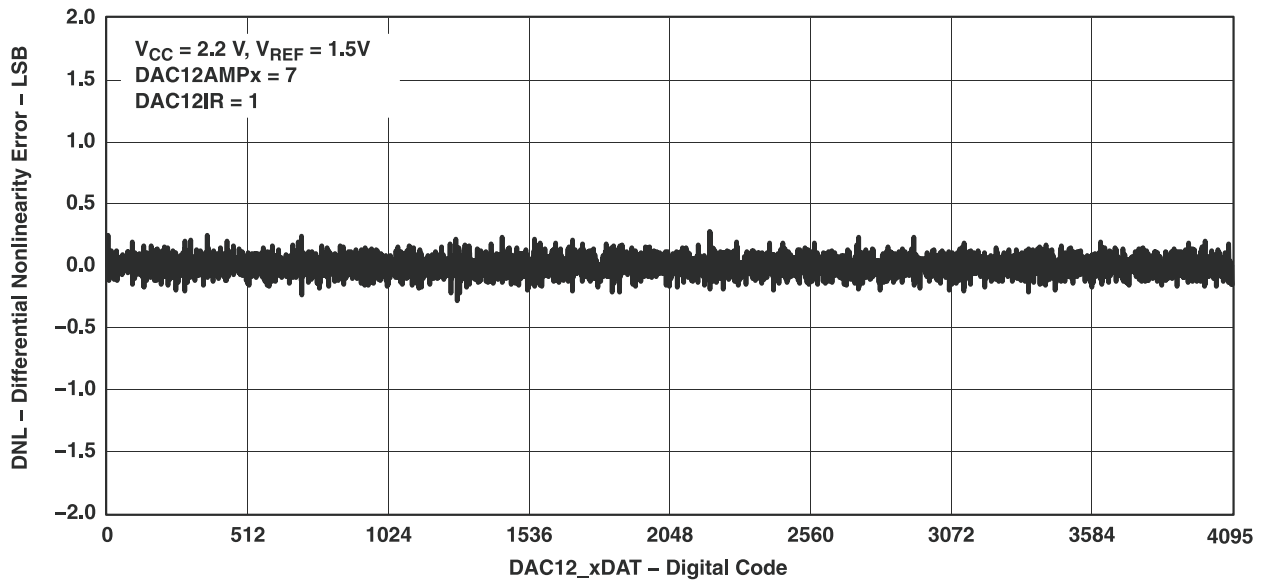

Figure 46.

## 12-Bit DAC Output Specifications – Electrical Characteristics

over recommended ranges of supply voltage and operating free-air temperature (unless otherwise noted)

PARAMETER		TEST CONDITIONS	V <sub>CC</sub>	MIN	TYP	MAX	UNIT
V <sub>O</sub>	Output voltage range <sup>(1)</sup> (See Figure 47)	No Load, V <sub>eREF+</sub> = AV <sub>CC</sub> , DAC12_xDAT = 0h, DAC12IR = 1, DAC12AMPx = 7	2.2 V/3 V	0		0.005	V
		No Load, V <sub>eREF+</sub> = AV <sub>CC</sub> , DAC12_xDAT = 0FFFh, DAC12IR = 1, DAC12AMPx = 7		AV <sub>CC</sub> - 0.05		AV <sub>CC</sub>	
		R <sub>Load</sub> = 3 kΩ, V <sub>eREF+</sub> = AV <sub>CC</sub> , DAC12_xDAT = 0h, DAC12IR = 1, DAC12AMPx = 7		0		0.1	
		R <sub>Load</sub> = 3 kΩ, V <sub>eREF+</sub> = AV <sub>CC</sub> , DAC12_xDAT = 0FFFh, DAC12IR = 1, DAC12AMPx = 7		AV <sub>CC</sub> - 0.13		AV <sub>CC</sub>	
C <sub>L(DAC12)</sub>	Max DAC12 load capacitance		2.2 V/3 V			100	pF
I <sub>L(DAC12)</sub>	Max DAC12 load current		2.2 V	-0.5		0.5	mA
			3 V	-1		1	
R <sub>O/P(DAC12)</sub>	Output resistance (See Figure 47)	R <sub>Load</sub> = 3 kΩ, V <sub>O/P(DAC12)</sub> = 0 V, DAC12AMPx = 7, DAC12_xDAT = 0h	2.2 V/3 V		150	250	Ω
		R <sub>Load</sub> = 3 kΩ, V <sub>O/P(DAC12)</sub> = 0 V, DAC12AMPx = 7, DAC12_xDAT = 0FFFh			150	250	
		R <sub>Load</sub> = 3 kΩ, 0.3 V ≤ V <sub>O/P(DAC12)</sub> ≤ AV <sub>CC</sub> - 0.3 V, DAC12AMPx = 7			1	4	

(1) Data is valid after the offset calibration of the output amplifier.

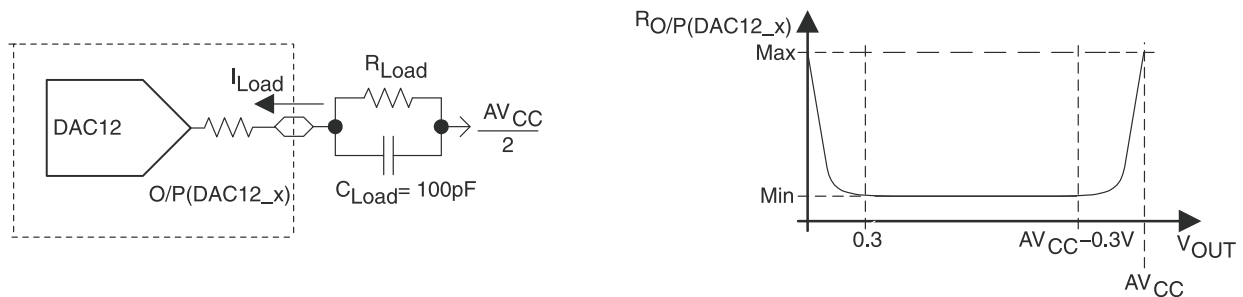

Figure 47. DAC12\_x Output Resistance Tests

## 12-Bit DAC Reference Input Specifications – Electrical Characteristics

over recommended ranges of supply voltage and operating free-air temperature (unless otherwise noted)

PARAMETER		TEST CONDITIONS	V <sub>CC</sub>	MIN	TYP	MAX	UNIT
V <sub>eREF+</sub>	Reference input voltage range	DAC12IR = 0 <sup>(1)(2)</sup>	2.2 V/3 V		AV <sub>CC</sub> /3	AV <sub>CC</sub> + 0.2	V
		DAC12IR = 1 <sup>(3)(4)</sup>			AV <sub>CC</sub>	AV <sub>CC</sub> + 0.2	
R <sub>i(VREF+)</sub> , R <sub>i(VeREF+)</sub>	Reference input resistance	DAC12_0 IR = DAC12_1 IR = 0	2.2 V/3 V	20			MΩ
		DAC12_0 IR = 1, DAC12_1 IR = 0		40	48	56	kΩ
		DAC12_0 IR = 0, DAC12_1 IR = 1					
		DAC12_0 IR = 0, DAC12_1 IR = 1 SREF <sub>x</sub> <sup>(5)</sup>		20	24	28	

- (1) For a full-scale output, the reference input voltage can be as high as 1/3 of the maximum output voltage swing (AV<sub>CC</sub>).
- (2) The maximum voltage applied at reference input voltage terminal V<sub>eREF+</sub> = [AV<sub>CC</sub> - V<sub>E(O)</sub>] / [3 x (1 + E<sub>G</sub>)].
- (3) For a full-scale output, the reference input voltage can be as high as the maximum output voltage swing (AV<sub>CC</sub>).
- (4) The maximum voltage applied at reference input voltage terminal V<sub>eREF+</sub> = [AV<sub>CC</sub> - V<sub>E(O)</sub>] / (1 + E<sub>G</sub>).
- (5) When DAC12IR = 1 and DAC12SREF<sub>x</sub> = 0 or 1 for both channels, the reference input resistive dividers for each DAC are in parallel reducing the reference input resistance.

12-Bit DAC Dynamic Specifications,  $V_{REF} = V_{CC}$ , DAC12IR = 1 – Electrical Characteristics

over recommended ranges of supply voltage and operating free-air temperature (unless otherwise noted)

PARAMETER		TEST CONDITIONS		$V_{CC}$	MIN	TYP	MAX	UNIT
$t_{ON}$	SR	DAC12_xDAT = 800h, Error $_{V(O)}$ < $\pm 0.5$ LSB <sup>(1)</sup> (See Figure 48)	DAC12AMPx = 0 $\rightarrow$ {2, 3, 4}	2.2 V/3 V	60	120	$\mu$ s	
			DAC12AMPx = 0 $\rightarrow$ {5, 6}		15	30		
			DAC12AMPx = 0 $\rightarrow$ 7		6	12		
$t_{S(FS)}$	Settling time, full scale	DAC12_xDAT = 80h $\rightarrow$ F7Fh $\rightarrow$ 80h	DAC12AMPx = 2	2.2 V/3 V	100	200	$\mu$ s	
			DAC12AMPx = 3, 5		40	80		
			DAC12AMPx = 4, 6, 7		15	30		
$t_{S(C-C)}$	Settling time, code to code	DAC12_xDAT = 3F8h $\rightarrow$ 408h $\rightarrow$ 3F8h	DAC12AMPx = 2	2.2 V/3 V	5		$\mu$ s	
			DAC12AMPx = 3, 5		2			
			DAC12AMPx = 4, 6, 7		1			
SR	Slew rate <sup>(2)</sup>	DAC12_xDAT = 80h $\rightarrow$ F7Fh $\rightarrow$ 80h	DAC12AMPx = 2	2.2 V/3 V	0.05	0.12	V/ $\mu$ s	
			DAC12AMPx = 3, 5		0.35	0.7		
			DAC12AMPx = 4, 6, 7		1.5	2.7		
	Glitch energy, full scale	DAC12_xDAT = 80h $\rightarrow$ F7Fh $\rightarrow$ 80h	DAC12AMPx = 2	2.2 V/3 V	600		nV-s	
			DAC12AMPx = 3, 5		150			
			DAC12AMPx = 4, 6, 7		30			
BW <sub>-3dB</sub>	3-dB bandwidth, $V_{DC} = 1.5$ V, $V_{AC} = 0.1$ V <sub>PP</sub> (See Figure 50)	DAC12AMPx = {2, 3, 4}, DAC12SREFx = 2, DAC12IR = 1, DAC12_xDAT = 800h	2.2 V/3 V	40		kHz		
		DAC12AMPx = {5, 6}, DAC12SREFx = 2, DAC12IR = 1, DAC12_xDAT = 800h		180				
		DAC12AMPx = 7, DAC12SREFx = 2, DAC12IR = 1, DAC12_xDAT = 800h		550				
	Channel-to-channel crosstalk <sup>(3)</sup> (See Figure 51)	DAC12_0DAT = 800h, No load, DAC12_1DAT = 80h $\leftrightarrow$ F7Fh, $R_{Load} = 3$ k $\Omega$ , $f_{DAC12\_1OUT} = 10$ kHz, Duty cycle = 50%	2.2 V/3 V	-80		dB		
		DAC12_0DAT = 80h $\leftrightarrow$ F7Fh, $R_{Load} = 3$ k $\Omega$ , DAC12_1DAT = 800h, No load, $f_{DAC12\_0OUT} = 10$ kHz, Duty cycle = 50%		-80				

- (1)  $R_{Load}$  and  $C_{Load}$  are connected to  $AV_{SS}$  (not  $AV_{CC}/2$ ) in Figure 48.
- (2) Slew rate applies to output voltage steps  $\geq 200$  mV.
- (3)  $R_{LOAD} = 3$  k $\Omega$ ,  $C_{LOAD} = 100$  pF

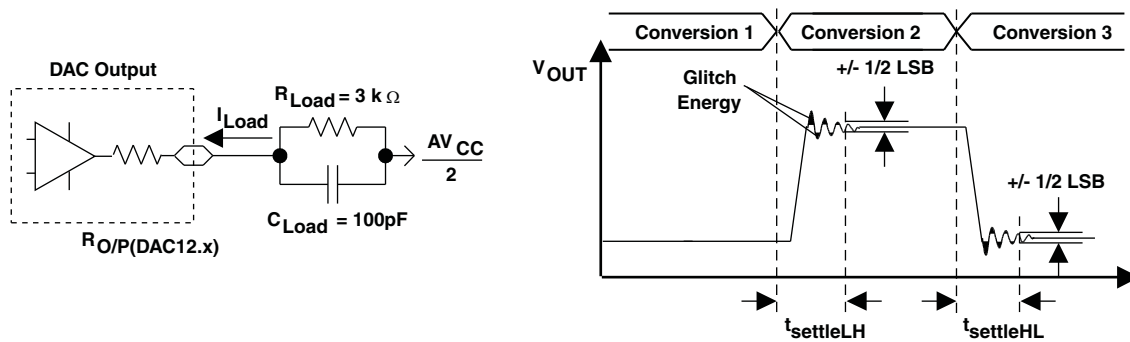

Figure 48. Settling Time and Glitch Energy Testing

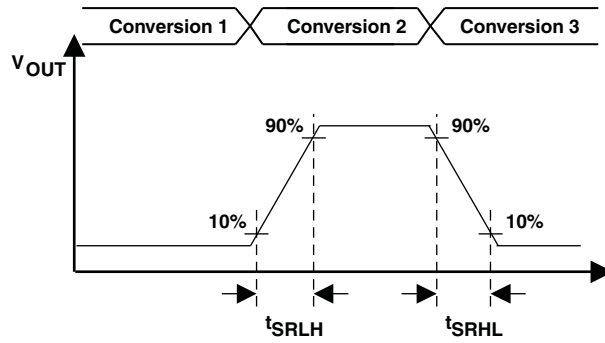

Figure 49. Slew Rate Testing

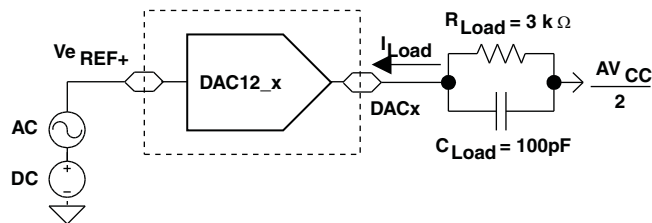

Figure 50. Test Conditions for 3-dB Bandwidth Specification

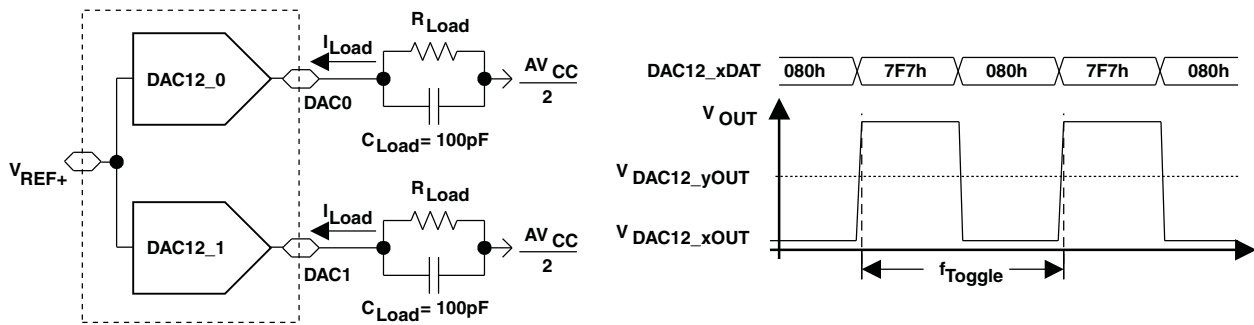

Figure 51. Crosstalk Test Conditions

### Flash Memory – Electrical Characteristics

over recommended ranges of supply voltage and operating free-air temperature (unless otherwise noted)

PARAMETER		TEST CONDITIONS	V <sub>CC</sub>	MIN	TYP	MAX	UNIT
V <sub>CC(PGM/ERASE)</sub>	Program and erase supply voltage			2.2		3.6	V
f <sub>FTG</sub>	Flash timing generator frequency			257		476	kHz
I <sub>PGM</sub>	Supply current from V <sub>CC</sub> during program		2.2 V/3.6 V		3	5	mA
I <sub>ERASE</sub>	Supply current from V <sub>CC</sub> during erase		2.2 V/3.6 V		3	7	mA
t <sub>CPT</sub>	Cumulative program time	See <sup>(1)</sup>	2.2 V/3.6 V			10	ms
t <sub>CMErase</sub>	Cumulative mass erase time		2.2 V/3.6 V	20			ms
	Program/Erase endurance			10 <sup>4</sup>	10 <sup>5</sup>		cycles
t <sub>Retention</sub>	Data retention duration	T <sub>J</sub> = 25°C		100			years
t <sub>Word</sub>	Word or byte program time	See <sup>(2)</sup>			35		t <sub>FTG</sub>
t <sub>Block, 0</sub>	Block program time for 1 <sup>st</sup> byte or word	See <sup>(2)</sup>			30		t <sub>FTG</sub>
t <sub>Block, 1-63</sub>	Block program time for each additional byte or word	See <sup>(2)</sup>			21		t <sub>FTG</sub>
t <sub>Block, End</sub>	Block program end-sequence wait time	See <sup>(2)</sup>			6		t <sub>FTG</sub>
t <sub>Mass Erase</sub>	Mass erase time	See <sup>(2)</sup>			10593		t <sub>FTG</sub>
t <sub>Seg Erase</sub>	Segment erase time	See <sup>(2)</sup>			4819		t <sub>FTG</sub>

- (1) The cumulative program time must not be exceeded when writing to a 64-byte flash block. This parameter applies to all programming methods: individual word/byte write and block write modes.
- (2) These values are hardwired into the Flash Controller's state machine (t<sub>FTG</sub> = 1/f<sub>FTG</sub>).

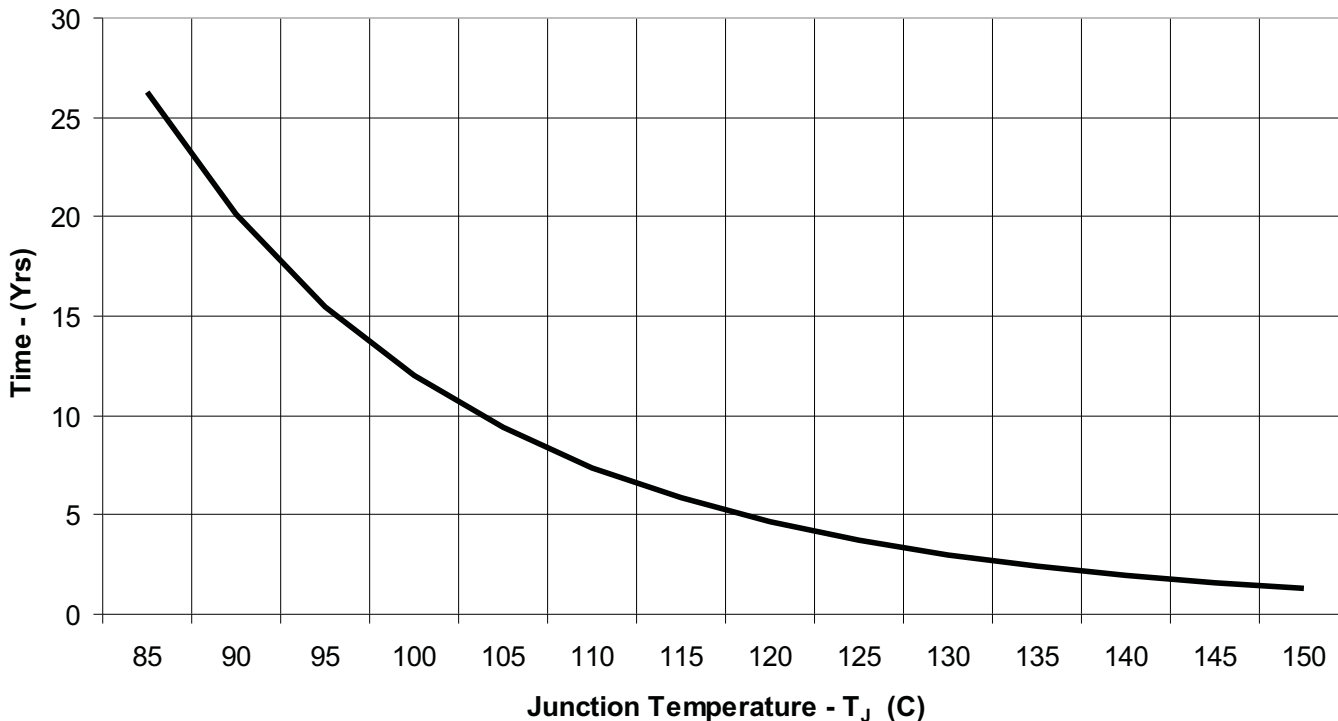

Figure 52. Flash Data Retention vs Junction Temperature

## RAM – Electrical Characteristics

over recommended ranges of supply voltage and operating free-air temperature (unless otherwise noted)

PARAMETER		TEST CONDITIONS	MIN	MAX	UNIT
$V_{(RAMh)}$	RAM retention supply voltage <sup>(1)</sup>	CPU halted	1.6		V

(1) This parameter defines the minimum supply voltage  $V_{CC}$  when the data in RAM remains unchanged. No program execution should happen during this supply voltage condition.

## JTAG and Spy-Bi-Wire Interface – Electrical Characteristics

over recommended ranges of supply voltage and operating free-air temperature (unless otherwise noted)

PARAMETER		TEST CONDITIONS	$V_{CC}$	MIN	TYP	MAX	UNIT
$f_{TCK}$	TCK input frequency	See <sup>(1)</sup>	2.2 V	0		5	MHz
			3 V	0		10	
$R_{Internal}$	Internal pulldown resistance on TEST	See <sup>(2)</sup>	2.2 V/3 V	25	60	90	k $\Omega$

(1)  $f_{TCK}$  may be restricted to meet the timing requirements of the module selected.

(2) TMS, TDI/TCLK, and TCK pullup resistors are implemented in all versions.

## JTAG Fuse<sup>(1)</sup> – Electrical Characteristics

over recommended ranges of supply voltage and operating free-air temperature (unless otherwise noted)

PARAMETER		TEST CONDITIONS	MIN	MAX	UNIT
$V_{CC(FB)}$	Supply voltage during fuse-blow condition	$T_A = 25^\circ\text{C}$	2.5		V
$V_{FB}$	Voltage level on TEST for fuse blow		6	7	V
$I_{FB}$	Supply current into TEST during fuse blow			100	mA
$t_{FB}$	Time to blow fuse			1	ms

(1) Once the fuse is blown, no further access to the MSP430 JTAG/Test and emulation features is possible. The JTAG block is switched to bypass mode.



**Port P2 Pin Schematic: P2.0 to P2.4, P2.6, and P2.7, Input/Output With Schmitt Trigger**

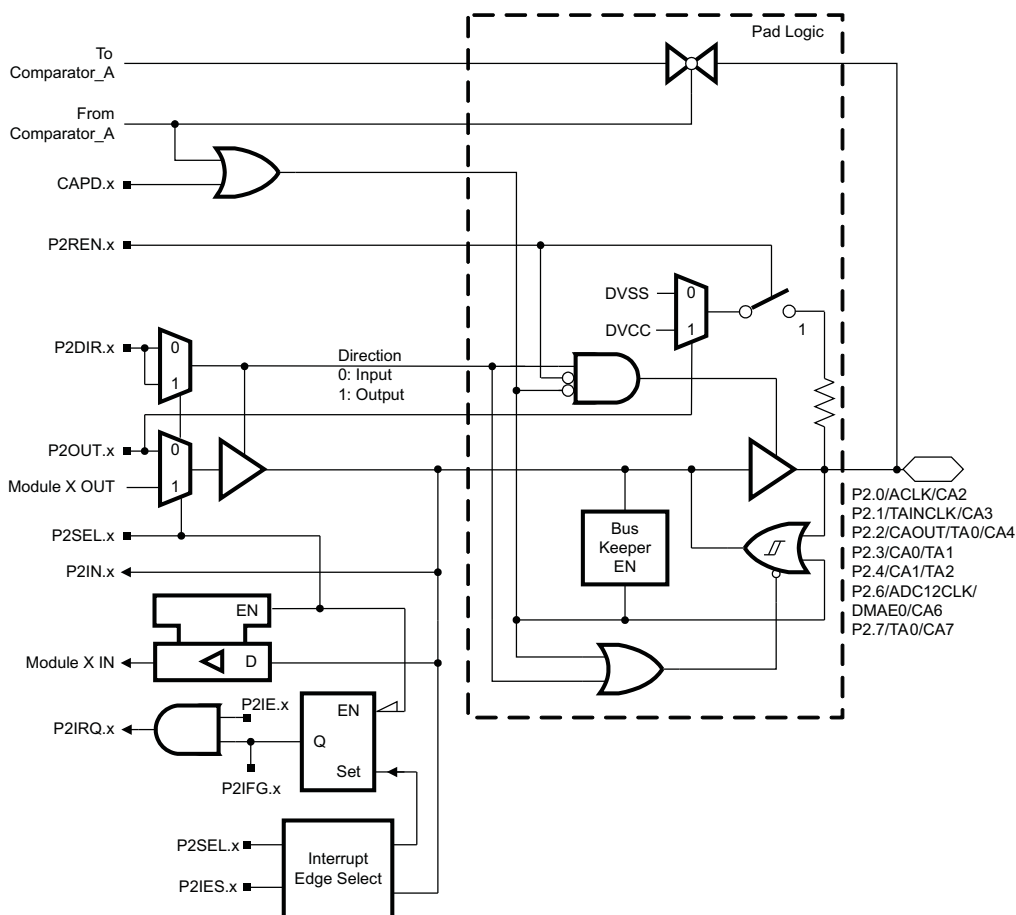

**Port P2.0, P2.3, P2.4, P2.6 and P2.7 Pin Functions**

Pin Name (P2.X)	X	FUNCTION	CONTROL BITS/SIGNALS <sup>(1)</sup>		
			CAPD.x	P2DIR.x	P2SEL.x
P2.0/ACLK/CA2	0	P2.0 (I/O)	0	I: 0; O: 1	0
		ACLK	0	1	1
		CA2	1	X	X
P2.1/TAINCLK/CA3	1	P2.2 (I/O)	0	I: 0; O: 1	0
		Timer_A3.INCLK	0	0	1
		DV <sub>SS</sub>	0	1	1
		CA3	1	X	X
P2.2/CAOUT/TA0/CA4	2	P2.2 (I/O)	0	I: 0; O: 1	0
		CAOUT	0	1	1
		Timer_A3.CCI0B	0	0	1
		CA4	1	X	X
P2.3/CA0/TA1	3	P2.3 (I/O)	0	I: 0; O: 1	0
		Timer_A3.TA1	0	1	1
		CA0	1	X	X

(1) X: Don't care

Pin Name (P2.X)	X	FUNCTION	CONTROL BITS/SIGNALS <sup>(1)</sup>		
			CAPD.x	P2DIR.x	P2SEL.x
P2.4/CA1/TA2	4	P2.4 (I/O)	0	I: 0; O: 1	0
		Timer_A3.TA2	0	1	X
		CA1	1	X	1
P2.6/ADC12CLK/ DMAE0/CA6	6	P2.6 (I/O)	0	I: 0; O: 1	0
		ADC12CLK	0	1	1
		DMAE0	0	0	1
		CA6	1	X	X
P2.7/TA0/CA7	7	P2.7 (I/O)	0	I: 0; O: 1	0
		Timer_A3.TA0	0	1	1
		CA7	1	X	X

**Port P2 Pin Schematic: P2.5, Input/Output With Schmitt Trigger and External R<sub>OSC</sub> for DCO**

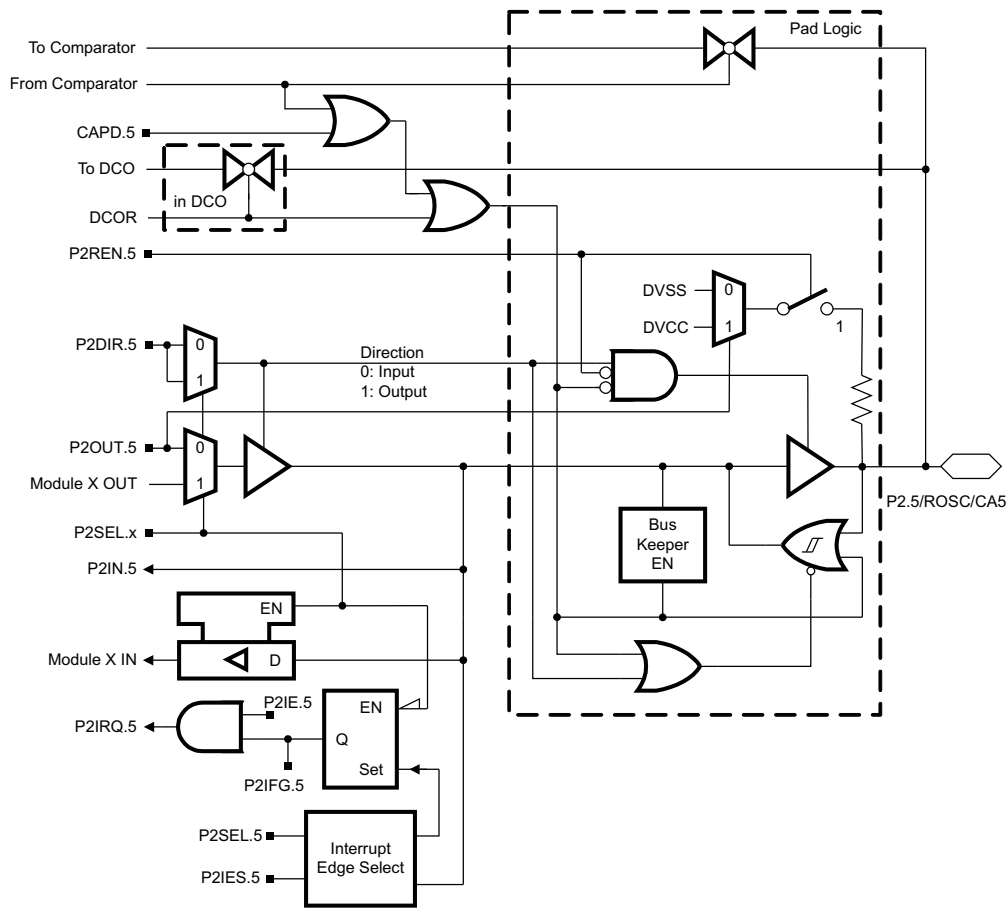

### Port P2 (P2.5) Pin Functions

PIN NAME (P2.X)	X	FUNCTION	CONTROL BITS/SIGNALS <sup>(1)</sup>			
			CAPD	DCOR	P2DIR.5	P2SEL.5
P2.5/R <sub>osc</sub> /CA5	5	P2.5 (I/O)	0	0	I: 0; O: 1	0
		R <sub>osc</sub> <sup>(2)</sup>	0	1	X	X
		DV <sub>SS</sub>	0	0	1	1
		R <sub>osc</sub>	1 or selected	0	X	X

- (1) X: Don't care
- (2) If R<sub>osc</sub> is used it is connected to an external resistor.

### Port P3 Pin Schematic: P3.0 to P3.7, Input/Output With Schmitt Trigger

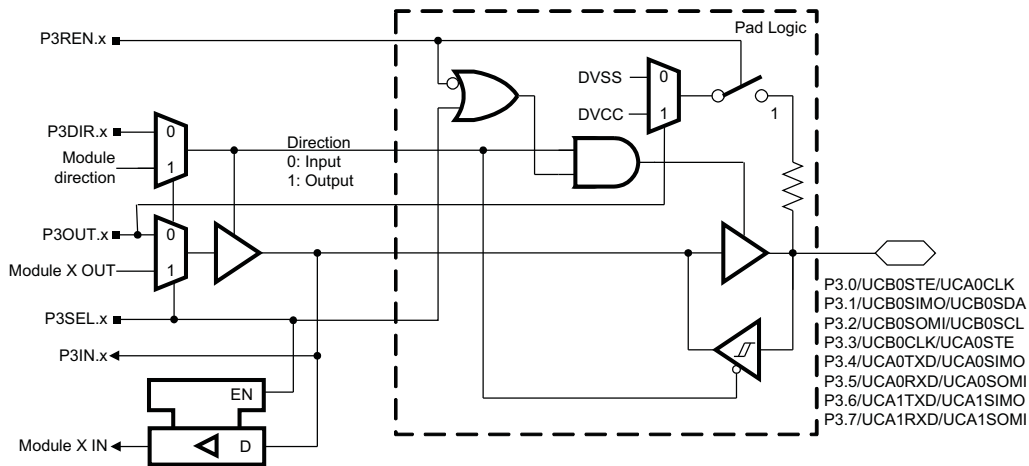

### Port P3 (P3.0) Pin Functions

PIN NAME (P3.X)	X	FUNCTION	CONTROL BITS/SIGNALS <sup>(1)</sup>	
			P3DIR.x	P3SEL.x
P3.0/UCB0STE/UCA0CLK	0	P3.0 (I/O)	I: 0; O: 1	0
		UCB0STE/UCA0CLK <sup>(2)(3)</sup>	X	1
P3.1/UCB0SIMO/UCB0SDA	1	P3.1 (I/O)	I: 0; O: 1	0
		UCB0SIMO/UCB0SDA <sup>(2)(4)</sup>	X	1
P3.2/UCB0SOMI/UCB0SCL	2	P3.2 (I/O)	I: 0; O: 1	0
		UCB0SOMI/UCB0SCL <sup>(2)(4)</sup>	X	1
P3.3/UCB0CLK/UCA0STE	3	P3.3 (I/O)	I: 0; O: 1	0
		UCB0CLK/UCA0STE <sup>(2)</sup>	X	1
P3.4/UCA0TXD/UCA0SIMO	4	P3.4 (I/O)	I: 0; O: 1	0
		UCA0TXD/UCA0SIMO <sup>(2)</sup>	X	1
P3.5/UCA0RXD/UCA0SOMI	5	P3.5 (I/O)	I: 0; O: 1	0
		UCA0RXD/UCA0SOMI <sup>(2)</sup>	X	1
P3.6/UCA1TXD/UCA1SIMO	6	P3.6 (I/O)	I: 0; O: 1	0
		UCA1TXD/UCA1SIMO <sup>(2)</sup>	X	1
P3.7/UCA1RXD/UCA1SOMI	7	P3.7 (I/O)	I: 0; O: 1	0
		UCA1RXD/UCA1SOMI <sup>(2)</sup>	X	1

- (1) X: Don't care
- (2) The pin direction is controlled by the USCI module.
- (3) UCA0CLK function takes precedence over UCB0STE function. If the pin is required as UCA0CLK input or output, USCI A0/B0 is forced to 3-wire SPI mode if 4-wire SPI mode is selected.
- (4) In case the I<sup>2</sup>C functionality is selected the output drives only the logical 0 to V<sub>SS</sub> level.

Port P4 Pin Schematic: P4.0 to P4.7, Input/Output With Schmitt Trigger

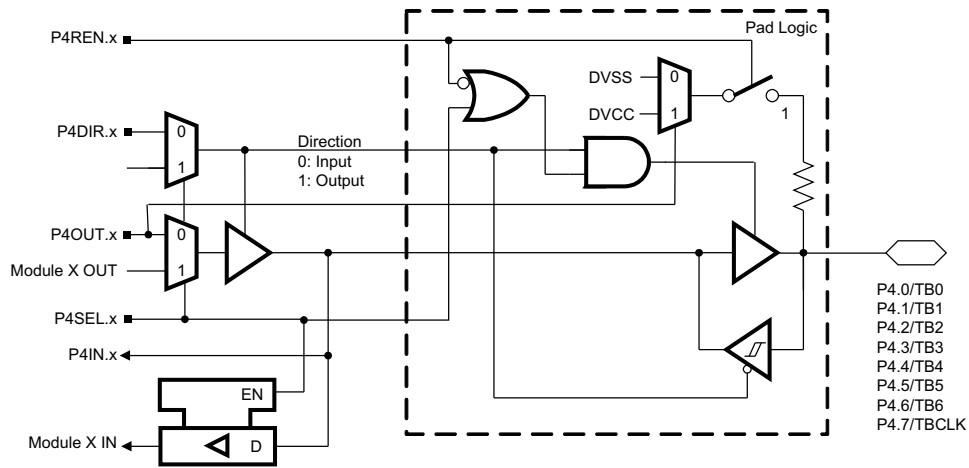

Port P4 (P4.0 to P4.7) Pin Functions

PIN NAME (P4.X)	X	FUNCTION	CONTROL BITS/SIGNALS	
			P4DIR.x	P4SEL.x
P4.0/TB0	0	P4.0 (I/O)	I: 0; O: 1	0
		Timer_B7.CCI0A and Timer_B7.CCI0B	0	1
		Timer_B7.TB0	1	1
P4.1/TB1	1	P4.1 (I/O)	I: 0; O: 1	0
		Timer_B7.CCI1A and Timer_B7.CCI1B	0	1
		Timer_B7.TB1	1	1
P4.2/TB2	2	P4.2 (I/O)	I: 0; O: 1	0
		Timer_B7.CCI2A and Timer_B7.CCI2B	0	1
		Timer_B7.TB2	1	1
P4.3/TB3	3	P4.3 (I/O)	I: 0; O: 1	0
		Timer_B7.CCI3A and Timer_B7.CCI3B	0	1
		Timer_B7.TB3	1	1
P4.4/TB4	4	P4.4 (I/O)	I: 0; O: 1	0
		Timer_B7.CCI4A and Timer_B7.CCI4B	0	1
		Timer_B7.TB4	1	1
P4.5/TB5	5	P4.5 (I/O)	I: 0; O: 1	0
		Timer_B7.CCI5A and Timer_B7.CCI5B	0	1
		Timer_B7.TB5	1	1
P4.6/TB6	6	P4.6 (I/O)	I: 0; O: 1	0
		Timer_B7.CCI6A and Timer_B7.CCI6B	0	1
		Timer_B7.TB6	1	1
P4.7/TBCLK	7	P4.7 (I/O)	I: 0; O: 1	0
		Timer_B7.TBCLK	1	1

### Port P5 Pin Schematic: P5.0 to P5.7, Input/Output With Schmitt Trigger

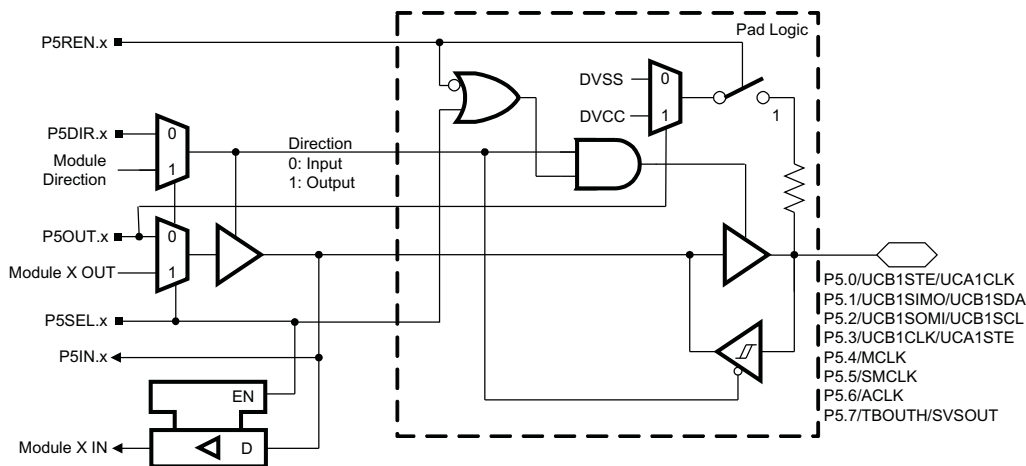

### Port P5 (P5.0 to P5.7) Pin Functions

PIN NAME (P5.X)	X	FUNCTION	CONTROL BITS/SIGNALS <sup>(1)</sup>	
			P5DIR.x	P5SEL.x
P5.0/UCB1STE/UCA1CLK	0	P5.0 (I/O)	I: 0; O: 1	0
		UCB1STE/UCA1CLK <sup>(2)(3)</sup>	X	1
P5.1/UCB1SIMO/UCB1SDA	1	P5.1 (I/O)	I: 0; O: 1	0
		UCB1SIMO/UCB1SDA <sup>(4)(5)</sup>	X	1
P5.2/UCB1SOMI/UCB1SCL	2	P5.2 (I/O)	I: 0; O: 1	0
		UCB1SOMI/UCB1SCL <sup>(4)(5)</sup>	X	1
P5.3/UCB1CLK/UCA1STE	3	P5.3 (I/O)	I: 0; O: 1	0
		UCB1CLK/UCA1STE <sup>(4)</sup>	X	1
P5.4/MCLK	4	P5.0 (I/O)	I: 0; O: 1	0
		MCLK	1	1
P5.5/SMCLK	5	P5.1 (I/O)	I: 0; O: 1	0
		SMCLK	1	1
P5.6/ACLK	6	P5.2 (I/O)	I: 0; O: 1	0
		ACLK	1	1
P5.7/TBOUTH/SVSOUT	7	P5.7 (I/O)	I: 0; O: 1	0
		TBOUTH	0	1
		SVSOUT	1	1

- (1) X: Don't care
- (2) The pin direction is controlled by the USCI module.
- (3) UCA1CLK function takes precedence over UCB1STE function. If the pin is required as UCA1CLK input or output USCI A1/B1 will be forced to 3-wire SPI mode if 4-wire SPI mode is selected.
- (4) The pin direction is controlled by the USCI module.
- (5) In case the I<sup>2</sup>C functionality is selected the output drives only the logical 0 to V<sub>SS</sub> level.

Port P6 Pin Schematic: P6.0 to P6.4, Input/Output With Schmitt Trigger

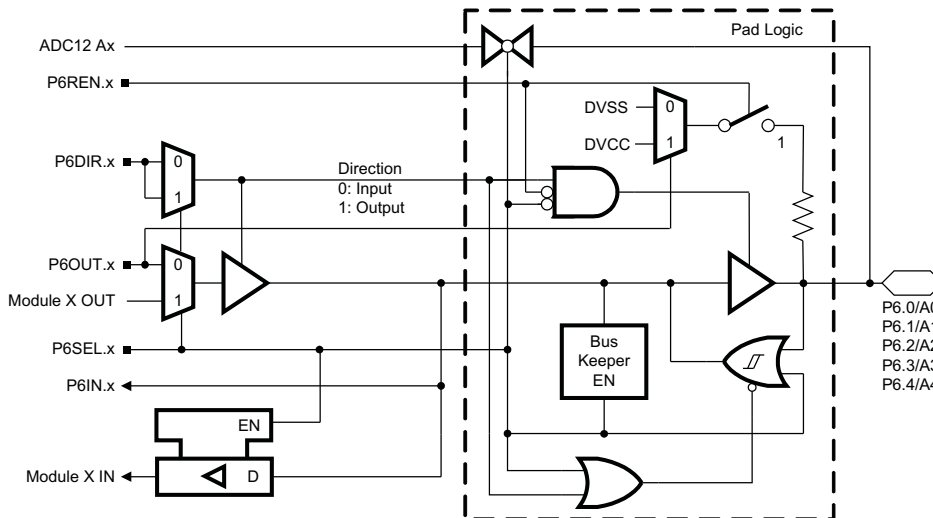

Port P6 (P6.0 to P6.4) Pin Functions

PIN NAME (P6.X)	X	FUNCTION	CONTROL BITS/SIGNALS <sup>(1)</sup>	
			P6DIR.x	P6SEL.x
P6.0/A0	0	P6.0 (I/O)	I: 0; O: 1	0
		A0 <sup>(2)</sup>	X	X
P6.1/A1	1	P6.1 (I/O)	I: 0; O: 1	0
		A1 <sup>(3)</sup>	X	X
P6.2/A2	2	P6.2 (I/O)	I: 0; O: 1	0
		A2 <sup>(3)</sup>	X	X
P6.3/A3	3	P6.3 (I/O)	I: 0; O: 1	0
		A3 <sup>(3)</sup>	X	X
P6.4/A4	4	P6.3 (I/O)	I: 0; O: 1	0
		A4 <sup>(3)</sup>	X	X

(1) X: Don't care  
 (2) The ADC12 channel Ax is connected to AVss internally if not selected.  
 (3) The ADC12 channel Ax is connected to AVss internally if not selected.

**Port P6 Pin Schematic: P6.5 and P6.6, Input/Output With Schmitt Trigger**

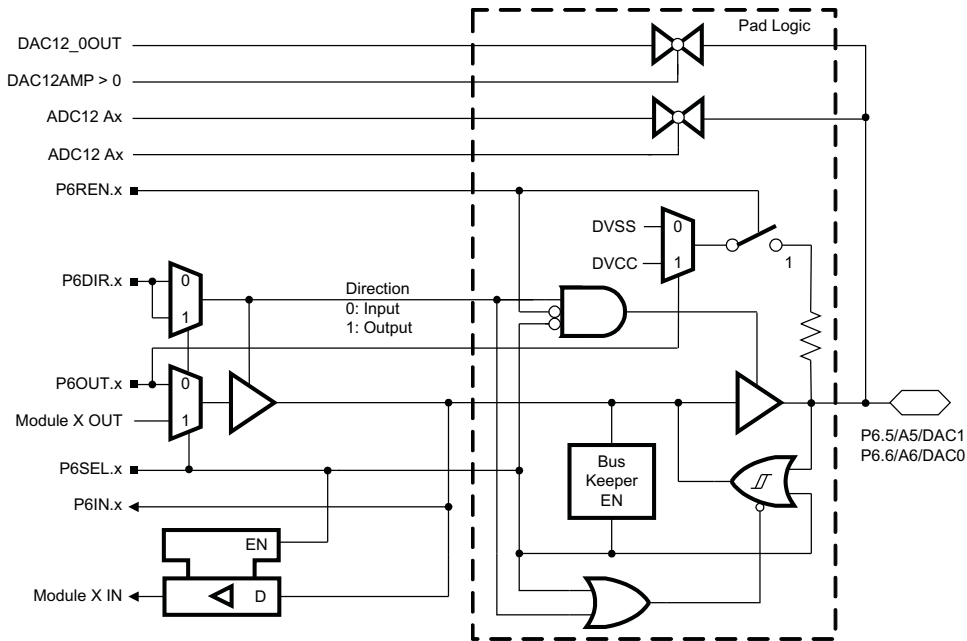

**Port P6 (P6.5 to P6.6) Pin Functions**

PIN NAME (P6.X)	X	FUNCTION	CONTROL BITS/SIGNALS <sup>(1)</sup>		
			P6DIR.x	P6SEL.x	CAPD.x or DAC12AMP > 0
P6.5/A5/DAC1	5	P6.5 (I/O)	I: 0; O: 1	0	0
		DV <sub>SS</sub>	1	1	0
		A5 <sup>(2)</sup>	X	X	1
		DAC1 (DA12OPS = 1) <sup>(3)</sup>	X	X	1
P6.6/A6/DAC0	6	P6.6 (I/O)	I: 0; O: 1	0	0
		DV <sub>SS</sub>	1	1	0
		A6 <sup>(4)</sup>	X	X	1
		DAC1 (DA12OPS = 0) <sup>(5)</sup>	X	X	1

- (1) X: Don't care
- (2) The ADC12 channel Ax is connected to AV<sub>SS</sub> internally if not selected.
- (3) The DAC outputs are floating if not selected.
- (4) The ADC12 channel Ax is connected to AV<sub>SS</sub> internally if not selected.
- (5) The DAC outputs are floating if not selected.

Port P6 Pin Schematic: P6.7, Input/Output With Schmitt Trigger

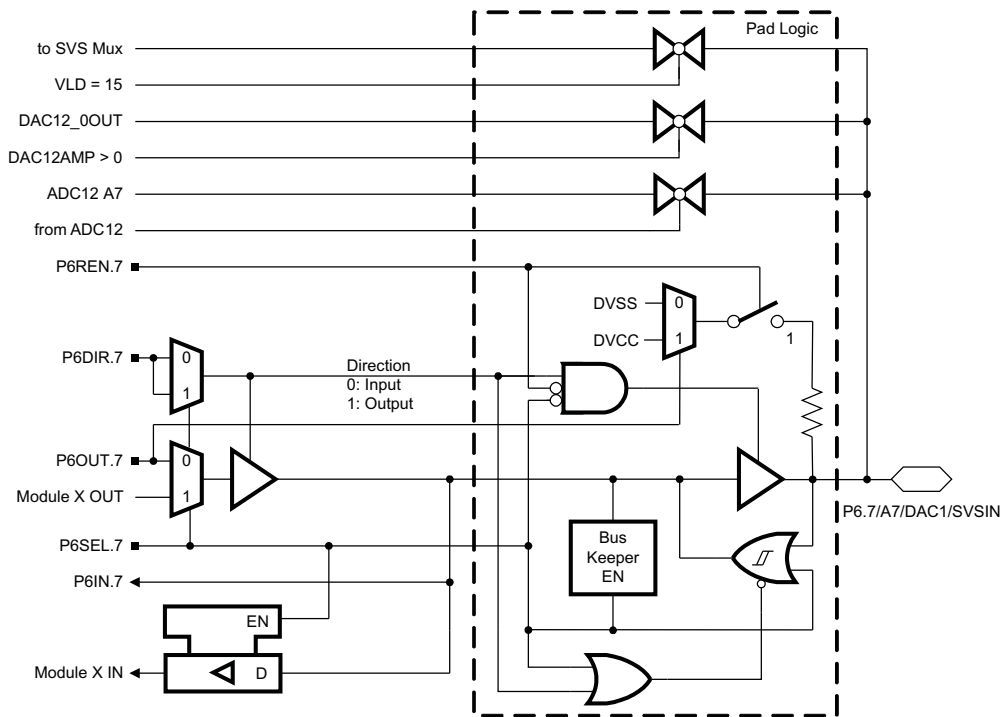

Port P6 (P6.7) Pin Functions

PIN NAME (P6.X)	X	FUNCTION	CONTROL BITS/SIGNALS <sup>(1)</sup>	
			P6DIR.x	P6SEL.x
P6.7/A7/DAC1/SVSIN	7	P6.7 (I/O)	I: 0; O: 1	0
		DV <sub>SS</sub>	1	1
		A7 <sup>(2)</sup>	X	X
		DAC1 (DA12OPS = 0) <sup>(3)</sup>	X	X
		SVSIN (VLD = 15)	X	X

- (1) X: Don't care
- (2) The ADC12 channel Ax is connected to AV<sub>SS</sub> internally if not selected.
- (3) The DAC outputs are floating if not selected.

**Port P7 Pin Schematic: P7.0 to P7.7, Input/Output With Schmitt Trigger**

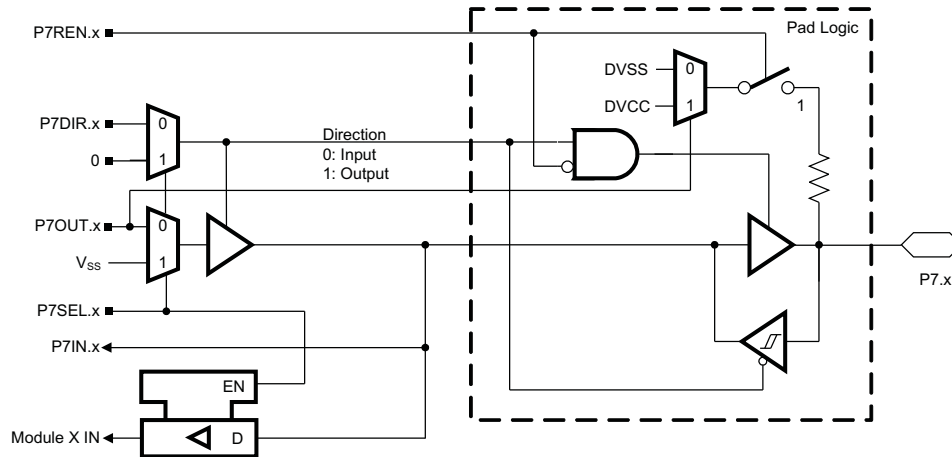

**Port P7 (P7.0 to P7.7) Pin Functions<sup>(4)</sup>**

PIN NAME (P7.X)	X	FUNCTION	CONTROL BITS/SIGNALS	
			P7DIR.x	P7SEL.x
P7.0	0	P7.0 (I/O)	I: 0; O: 1	0
		Input	X	1
P7.1	1	P7.1 (I/O)	I: 0; O: 1	0
		Input	X	1
P7.2	2	P7.2 (I/O)	I: 0; O: 1	0
		Input	X	1
P7.3	3	P7.3 (I/O)	I: 0; O: 1	0
		Input	X	1
P7.4	4	P7.4 (I/O)	I: 0; O: 1	0
		Input	X	1
P7.5	5	P7.5 (I/O)	I: 0; O: 1	0
		Input	X	1
P7.6	6	P7.6 (I/O)	I: 0; O: 1	0
		Input	X	1
P7.7	7	P7.7 (I/O)	I: 0; O: 1	0
		Input	X	1

(4) KGD only

Port P8 Pin Schematic: P8.0 to P8.5, Input/Output With Schmitt Trigger

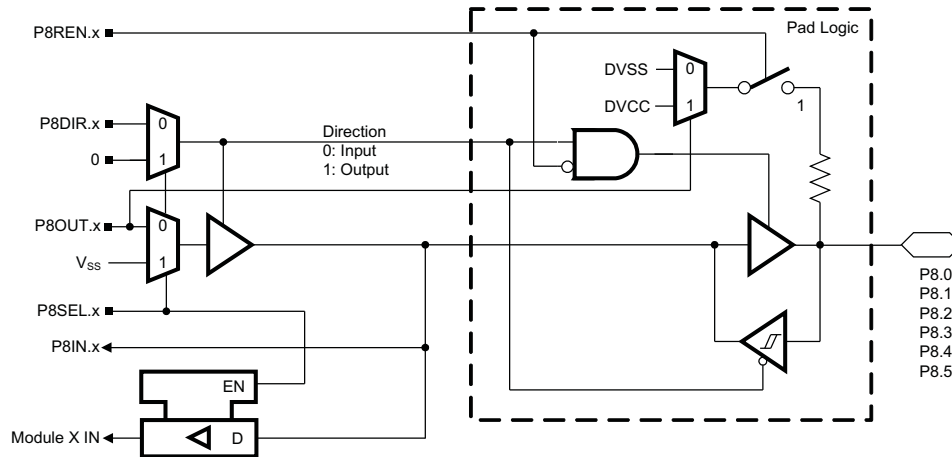

Port P8 (P8.0 to P8.5) Pin Functions<sup>(1)</sup>

PIN NAME (P8.X)	X	FUNCTION	CONTROL BITS/SIGNALS	
			P8DIR.x	P8SEL.x
P8.0	0	P8.0 (I/O)	I: 0; O: 1	0
		Input	X	1
P8.1	1	P8.1 (I/O)	I: 0; O: 1	0
		Input	X	1
P8.2	2	P8.2 (I/O)	I: 0; O: 1	0
		Input	X	1
P8.3	3	P8.3 (I/O)	I: 0; O: 1	0
		Input	X	1
P8.4	4	P8.4 (I/O)	I: 0; O: 1	0
		Input	X	1
P8.5	5	P8.5 (I/O)	I: 0; O: 1	0
		Input	X	1

(1) KGD only

**Port P8 Pin Schematic: P8.6, Input/Output With Schmitt Trigger**

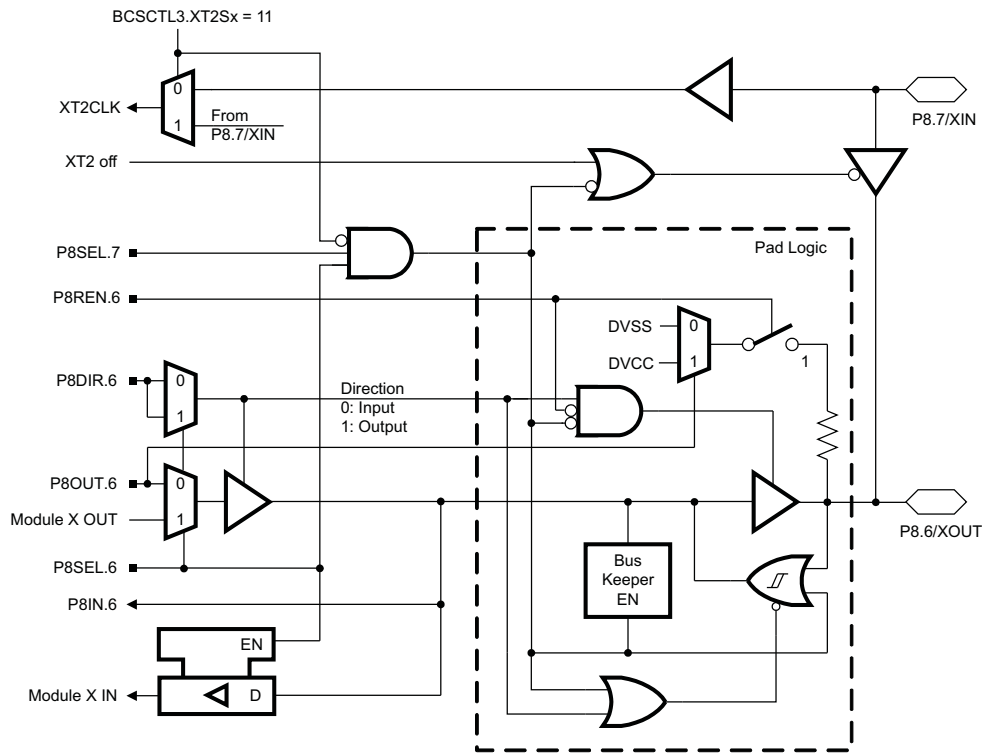

**Port P8 (P8.6) Pin Functions<sup>(1)</sup>**

PIN NAME (P8.X)	X	FUNCTION	CONTROL BITS/SIGNALS	
			P8DIR.x	P8SEL.x
P8.6/XOUT	6	P8.6 (I/O)	I: 0; O: 1	0
		XOUT (default)	0	1
		DV <sub>SS</sub>	1	1

(1) KGD only

Port P8 Pin Schematic: P8.7, Input/Output With Schmitt Trigger

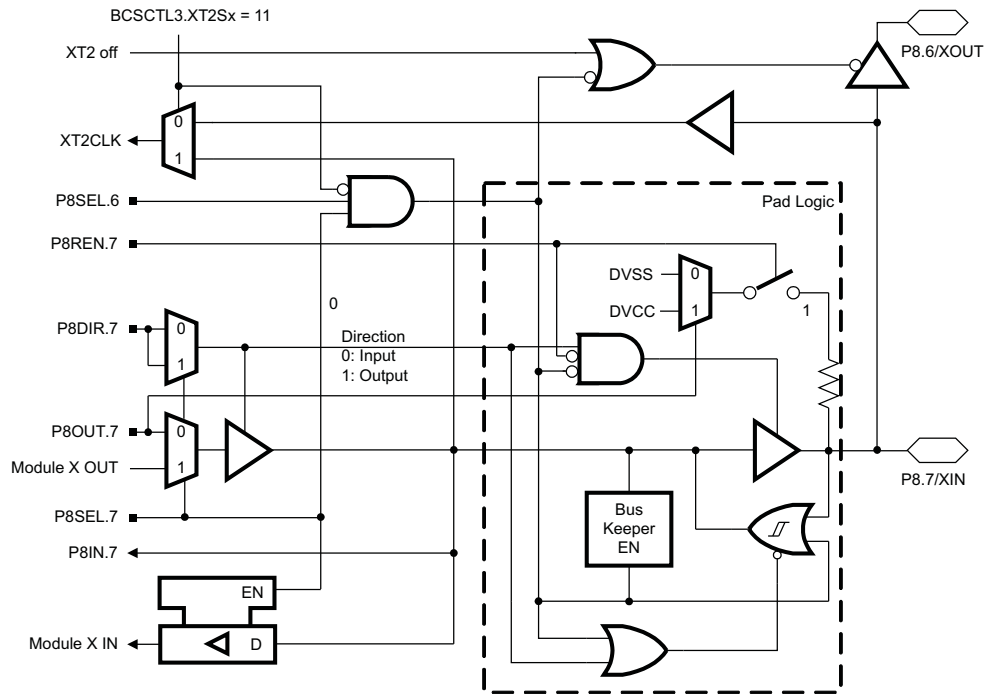

Port P8 (P8.7) Pin Functions<sup>(1)</sup>

PIN NAME (P8.X)	X	FUNCTION	CONTROL BITS/SIGNALS	
			P8DIR.x	P8SEL.x
P8.7/XIN	6	P8.7 (I/O)	I: 0; O: 1	0
		XIN (default)	0	1
		V <sub>SS</sub>	1	1

(1) KGD only

JTAG Pins: TMS, TCK, TDI/TCLK, TDO/TDI, Input/Output With Schmitt Trigger

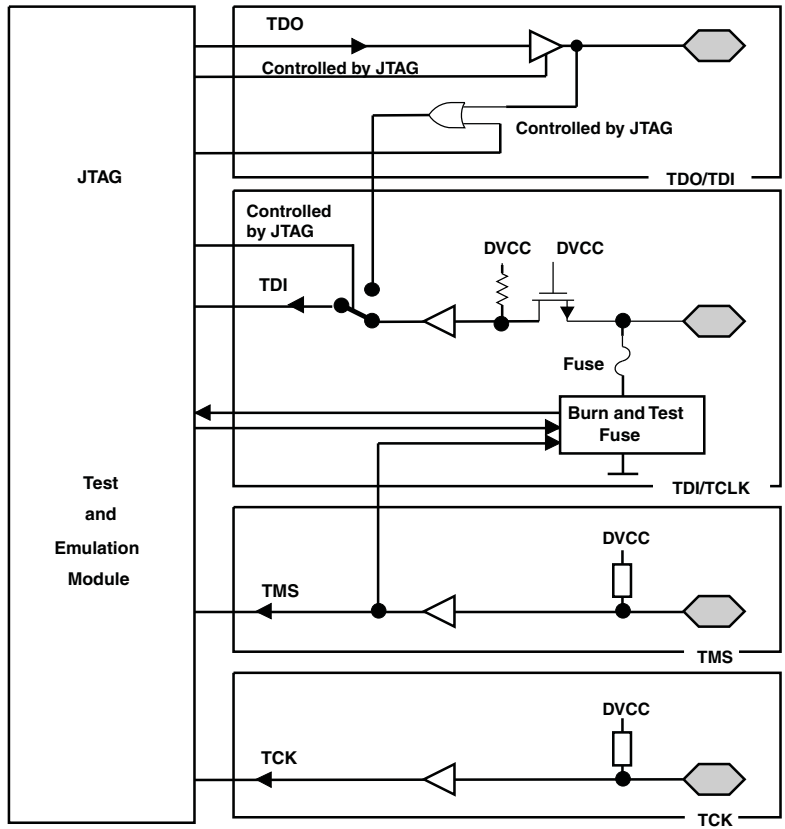

During Programming Activity and During Blowing of the Fuse, Pin TDO/TDI is Used to Apply the Test Input Data for JTAG Circuitry

## JTAG Fuse Check Mode

MSP430 devices that have the fuse on the TEST terminal have a fuse check mode that tests the continuity of the fuse the first time the JTAG port is accessed after a power-on reset (POR). When activated, a fuse check current,  $I_{TF}$ , of 1 mA at 3 V, 2.5 mA at 5 V can flow from the TEST pin to ground if the fuse is not burned. Care must be taken to avoid accidentally activating the fuse check mode and increasing overall system power consumption.

When the TEST pin is again taken low after a test or programming session, the fuse check mode and sense currents are terminated.

Activation of the fuse check mode occurs with the first negative edge on the TMS pin after power up or if TMS is being held low during power up. The second positive edge on the TMS pin deactivates the fuse check mode. After deactivation, the fuse check mode remains inactive until another POR occurs. After each POR the fuse check mode has the potential to be activated.

The fuse check current flows only when the fuse check mode is active and the TMS pin is in a low state (see [Figure 53](#)). Therefore, the additional current flow can be prevented by holding the TMS pin high (default condition).

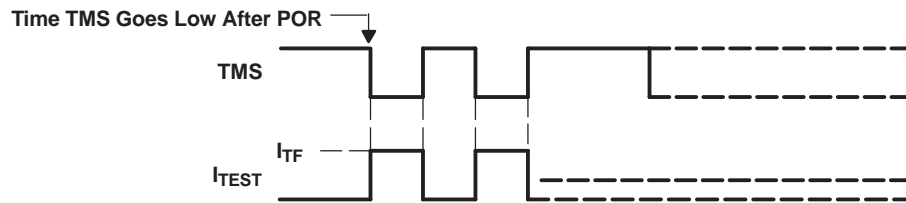

**Figure 53. Fuse Check Mode Current**

## REVISION HISTORY

Changes from Revision C (April 2013) to Revision D	Page
• Added bullet under SUPPORTS EXTREME TEMPERATURE APPLICATIONS section .....	1
• Deleted Ordering Information table note (2) referencing package information .....	2
• Changed Bare Die Information section .....	7

**PACKAGING INFORMATION**

Orderable Device	Status (1)	Package Type	Package Drawing	Pins	Package Qty	Eco Plan (2)	Lead/Ball Finish (6)	MSL Peak Temp (3)	Op Temp (°C)	Device Marking (4/5)	Samples
MSP430F2619SKGD1	ACTIVE	XCEPT	KGD	0	36	TBD	Call TI	N / A for Pkg Type	-55 to 150		<a href="#">Samples</a>
MSP430F2619SPM	ACTIVE	LQFP	PM	64	160	Green (RoHS & no Sb/Br)	CU NIPDAU	Level-3-260C-168 HR	-55 to 150	M430F2619SPM	<a href="#">Samples</a>

(1) The marketing status values are defined as follows:

**ACTIVE:** Product device recommended for new designs.

**LIFEBUY:** TI has announced that the device will be discontinued, and a lifetime-buy period is in effect.

**NRND:** Not recommended for new designs. Device is in production to support existing customers, but TI does not recommend using this part in a new design.

**PREVIEW:** Device has been announced but is not in production. Samples may or may not be available.

**OBSOLETE:** TI has discontinued the production of the device.

(2) Eco Plan - The planned eco-friendly classification: Pb-Free (RoHS), Pb-Free (RoHS Exempt), or Green (RoHS & no Sb/Br) - please check <http://www.ti.com/productcontent> for the latest availability information and additional product content details.

**TBD:** The Pb-Free/Green conversion plan has not been defined.

**Pb-Free (RoHS):** TI's terms "Lead-Free" or "Pb-Free" mean semiconductor products that are compatible with the current RoHS requirements for all 6 substances, including the requirement that lead not exceed 0.1% by weight in homogeneous materials. Where designed to be soldered at high temperatures, TI Pb-Free products are suitable for use in specified lead-free processes.

**Pb-Free (RoHS Exempt):** This component has a RoHS exemption for either 1) lead-based flip-chip solder bumps used between the die and package, or 2) lead-based die adhesive used between the die and leadframe. The component is otherwise considered Pb-Free (RoHS compatible) as defined above.

**Green (RoHS & no Sb/Br):** TI defines "Green" to mean Pb-Free (RoHS compatible), and free of Bromine (Br) and Antimony (Sb) based flame retardants (Br or Sb do not exceed 0.1% by weight in homogeneous material)

(3) MSL, Peak Temp. - The Moisture Sensitivity Level rating according to the JEDEC industry standard classifications, and peak solder temperature.

(4) There may be additional marking, which relates to the logo, the lot trace code information, or the environmental category on the device.

(5) Multiple Device Markings will be inside parentheses. Only one Device Marking contained in parentheses and separated by a "~" will appear on a device. If a line is indented then it is a continuation of the previous line and the two combined represent the entire Device Marking for that device.

(6) Lead/Ball Finish - Orderable Devices may have multiple material finish options. Finish options are separated by a vertical ruled line. Lead/Ball Finish values may wrap to two lines if the finish value exceeds the maximum column width.

**Important Information and Disclaimer:** The information provided on this page represents TI's knowledge and belief as of the date that it is provided. TI bases its knowledge and belief on information provided by third parties, and makes no representation or warranty as to the accuracy of such information. Efforts are underway to better integrate information from third parties. TI has taken and continues to take reasonable steps to provide representative and accurate information but may not have conducted destructive testing or chemical analysis on incoming materials and chemicals. TI and TI suppliers consider certain information to be proprietary, and thus CAS numbers and other limited information may not be available for release.

In no event shall TI's liability arising out of such information exceed the total purchase price of the TI part(s) at issue in this document sold by TI to Customer on an annual basis.

PM (S-PQFP-G64)

PLASTIC QUAD FLATPACK

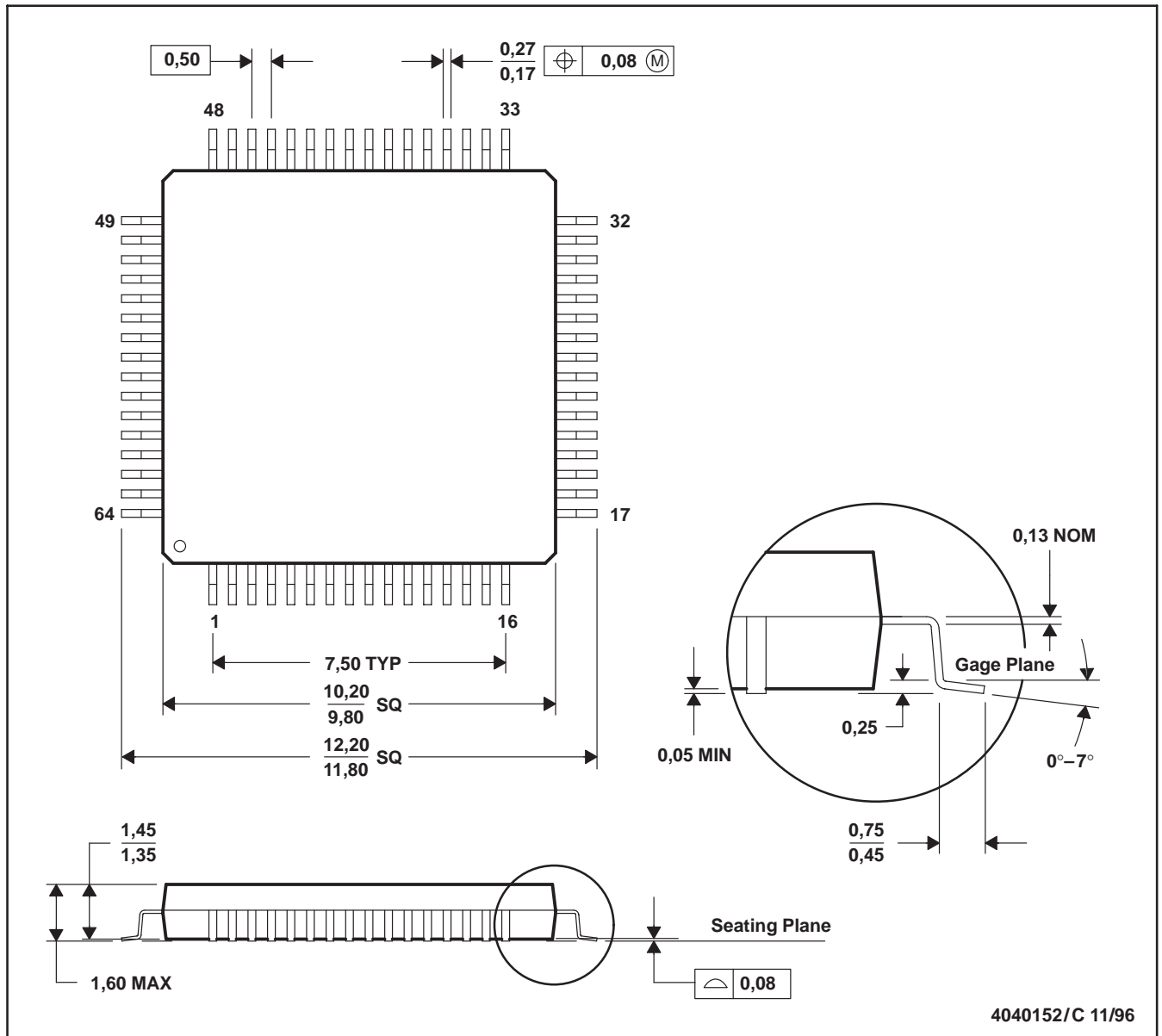

- NOTES: A. All linear dimensions are in millimeters.  
 B. This drawing is subject to change without notice.  
 C. Falls within JEDEC MS-026  
 D. May also be thermally enhanced plastic with leads connected to the die pads.

## IMPORTANT NOTICE

Texas Instruments Incorporated and its subsidiaries (TI) reserve the right to make corrections, enhancements, improvements and other changes to its semiconductor products and services per JESD46, latest issue, and to discontinue any product or service per JESD48, latest issue. Buyers should obtain the latest relevant information before placing orders and should verify that such information is current and complete. All semiconductor products (also referred to herein as "components") are sold subject to TI's terms and conditions of sale supplied at the time of order acknowledgment.

TI warrants performance of its components to the specifications applicable at the time of sale, in accordance with the warranty in TI's terms and conditions of sale of semiconductor products. Testing and other quality control techniques are used to the extent TI deems necessary to support this warranty. Except where mandated by applicable law, testing of all parameters of each component is not necessarily performed.

TI assumes no liability for applications assistance or the design of Buyers' products. Buyers are responsible for their products and applications using TI components. To minimize the risks associated with Buyers' products and applications, Buyers should provide adequate design and operating safeguards.

TI does not warrant or represent that any license, either express or implied, is granted under any patent right, copyright, mask work right, or other intellectual property right relating to any combination, machine, or process in which TI components or services are used. Information published by TI regarding third-party products or services does not constitute a license to use such products or services or a warranty or endorsement thereof. Use of such information may require a license from a third party under the patents or other intellectual property of the third party, or a license from TI under the patents or other intellectual property of TI.

Reproduction of significant portions of TI information in TI data books or data sheets is permissible only if reproduction is without alteration and is accompanied by all associated warranties, conditions, limitations, and notices. TI is not responsible or liable for such altered documentation. Information of third parties may be subject to additional restrictions.

Resale of TI components or services with statements different from or beyond the parameters stated by TI for that component or service voids all express and any implied warranties for the associated TI component or service and is an unfair and deceptive business practice. TI is not responsible or liable for any such statements.

Buyer acknowledges and agrees that it is solely responsible for compliance with all legal, regulatory and safety-related requirements concerning its products, and any use of TI components in its applications, notwithstanding any applications-related information or support that may be provided by TI. Buyer represents and agrees that it has all the necessary expertise to create and implement safeguards which anticipate dangerous consequences of failures, monitor failures and their consequences, lessen the likelihood of failures that might cause harm and take appropriate remedial actions. Buyer will fully indemnify TI and its representatives against any damages arising out of the use of any TI components in safety-critical applications.

In some cases, TI components may be promoted specifically to facilitate safety-related applications. With such components, TI's goal is to help enable customers to design and create their own end-product solutions that meet applicable functional safety standards and requirements. Nonetheless, such components are subject to these terms.

No TI components are authorized for use in FDA Class III (or similar life-critical medical equipment) unless authorized officers of the parties have executed a special agreement specifically governing such use.

Only those TI components which TI has specifically designated as military grade or "enhanced plastic" are designed and intended for use in military/aerospace applications or environments. Buyer acknowledges and agrees that any military or aerospace use of TI components which have **not** been so designated is solely at the Buyer's risk, and that Buyer is solely responsible for compliance with all legal and regulatory requirements in connection with such use.

TI has specifically designated certain components as meeting ISO/TS16949 requirements, mainly for automotive use. In any case of use of non-designated products, TI will not be responsible for any failure to meet ISO/TS16949.

### Products

Audio	<a href="http://www.ti.com/audio">www.ti.com/audio</a>
Amplifiers	<a href="http://amplifier.ti.com">amplifier.ti.com</a>
Data Converters	<a href="http://dataconverter.ti.com">dataconverter.ti.com</a>
DLP® Products	<a href="http://www.dlp.com">www.dlp.com</a>
DSP	<a href="http://dsp.ti.com">dsp.ti.com</a>
Clocks and Timers	<a href="http://www.ti.com/clocks">www.ti.com/clocks</a>
Interface	<a href="http://interface.ti.com">interface.ti.com</a>
Logic	<a href="http://logic.ti.com">logic.ti.com</a>
Power Mgmt	<a href="http://power.ti.com">power.ti.com</a>
Microcontrollers	<a href="http://microcontroller.ti.com">microcontroller.ti.com</a>
RFID	<a href="http://www.ti-rfid.com">www.ti-rfid.com</a>
OMAP Applications Processors	<a href="http://www.ti.com/omap">www.ti.com/omap</a>
Wireless Connectivity	<a href="http://www.ti.com/wirelessconnectivity">www.ti.com/wirelessconnectivity</a>

### Applications

Automotive and Transportation	<a href="http://www.ti.com/automotive">www.ti.com/automotive</a>
Communications and Telecom	<a href="http://www.ti.com/communications">www.ti.com/communications</a>
Computers and Peripherals	<a href="http://www.ti.com/computers">www.ti.com/computers</a>
Consumer Electronics	<a href="http://www.ti.com/consumer-apps">www.ti.com/consumer-apps</a>
Energy and Lighting	<a href="http://www.ti.com/energy">www.ti.com/energy</a>
Industrial	<a href="http://www.ti.com/industrial">www.ti.com/industrial</a>
Medical	<a href="http://www.ti.com/medical">www.ti.com/medical</a>
Security	<a href="http://www.ti.com/security">www.ti.com/security</a>
Space, Avionics and Defense	<a href="http://www.ti.com/space-avionics-defense">www.ti.com/space-avionics-defense</a>
Video and Imaging	<a href="http://www.ti.com/video">www.ti.com/video</a>

### TI E2E Community

[e2e.ti.com](http://e2e.ti.com)