

**Rotation speed monitor
1-channel
MS24-112-R**

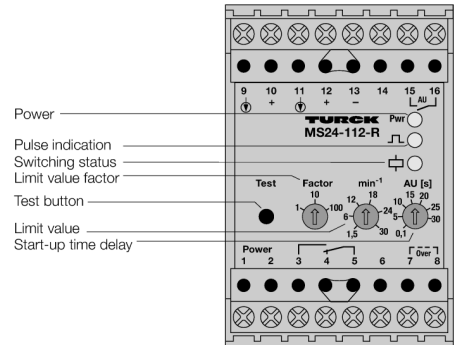
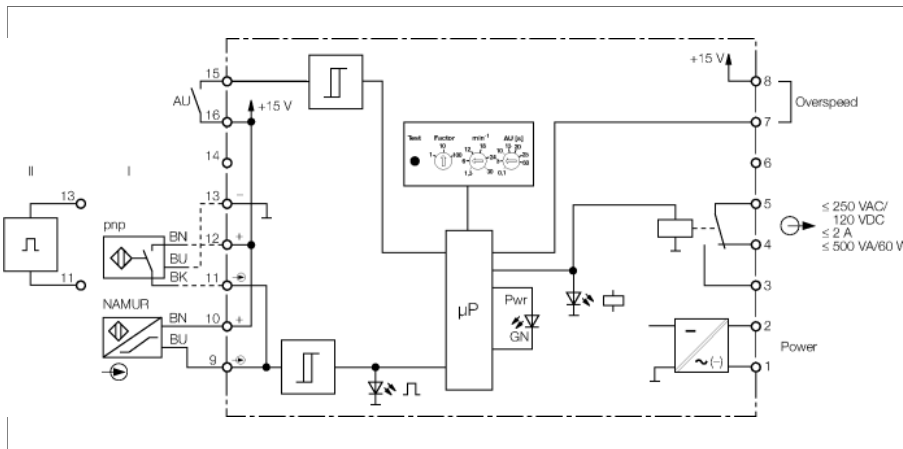

The rotation speed monitor MS24-112-R is controlled via 3-wire pnp sensors, sensors acc. to EN 60947-5-6 (I) or signal sources with pulse levels of 10...30 VDC.

Bridging terminals 7 and 8 activates the *overspeed monitoring* mode. In case of rotation speeds above the adjusted limit value, the relay is de-energized. Without bridging, the device works *inunderspeed monitoring* mode.

In case of rotation speeds below the adjusted limit value, the relay is energized. The device features three overlapping measuring ranges and is thus easily adaptable to the corresponding application. First, the measuring range is set with a three-step switch and then the switchpoint is fine adjusted with the potentiometer at the front.

The switchpoint can be set during the start-up phase with the test button at the front, without having to switch off the output relay: As long as the test button is being pressed, the output relay remains energized.

To provide optimum response times for applications with relatively low speeds, the device operates on the digital pulse principle.

The switching status of the output relay is indicated by a yellow LED and operational readiness by a green LED. Input pulses are indicated by the related yellow LED.

In *overspeed monitoring mode* a start-up delay can be programmed for the drive. During this period the limit value relay is energized, preventing this way underspeed indication and system shut-down during the start-up phase. The start-up delay is activated via a potential-free contact at the terminals 15/16 or by applying power to the bridged terminals 15/16.

- **Rotation speed monitoring for overspeed or underspeed**
- **Monitoring range: 25 mHz...50 Hz (1.5... 3 000) min⁻¹)**
- **Line monitored for wire-break/short-circuit**
- **Removable terminal blocks**
- **One relay output as changeover contact**
- **Start-up bypass, activatable**
- **Galvanic separation of input circuits, output circuits and power supply**

**Rotation speed monitor
1-channel
MS24-112-R**

Type	MS24-112-R
Ident-No.	0518003
Nominal voltage	Universal voltage supply unit
Operating voltage	20...250 VAC
Frequency	40...70 Hz
Operating voltage range	20...250 VDC
Power consumption	≤ 3 W
Monitoring range / setting range:	≤ 1,5...3000 min ⁻¹
Monitoring range / setting range:	1,5...30 min ⁻¹
Monitoring range / setting range:	15...300 min ⁻¹
Monitoring range / setting range:	150...3000 min ⁻¹
Input frequency	60000 min ⁻¹
Pulse time	≥ 0.02 ms
Pulse stop	≥ 0.02 ms
NAMUR	EN-60947-5-6
No-load voltage	8.2 VDC
Short-circuit current	8.2 mA
Input resistance	1 kΩ
Cable resistance	≤ 50 Ω
Switch-on threshold:	1.55 mA
Switch-off threshold:	1.75 mA
3-wire input	
No-load voltage	15 VDC
Current	≤ 30 mA
0-signal	0...3VDC
1-signal	5...30 VDC
External signal source	
0-signal	0-3 VDC
1-signal	5...30 VDC
Input resistance	26000 Ω
Output circuits (digital)	1 x relay (change-over)
Relay switching voltage	≤ 250 VAC/120 VDC
Switching current per output	≤ 2 A
Switching capacity per output	≤ 500 VA/60 W
Switching frequency	≤ 10 Hz
Contact quality	AgNi, 3μ Au
Temperature drift	≤ 0.005 % / K
Galvanic separation	
Test voltage	2.5 kV
Rated voltage	250 V
Indication	
Operational readiness	green
Pulse input	yellow
Switching state	yellow
Protection class	IP20
Ambient temperature	-25...+60 °C
Dimensions	75x 50x 110 mm
Weight	251 g
Mounting instruction	For mounting on DIN rail or mounting panel
Housing material	Polycarbonate/ABS
Electrical connection	2 x 8-pole removable terminal blocks, reverse polarity protected, screw connection
Terminal cross-section	1 x 2.5 mm ² / 2 x 1.5 mm ²

Dimensions

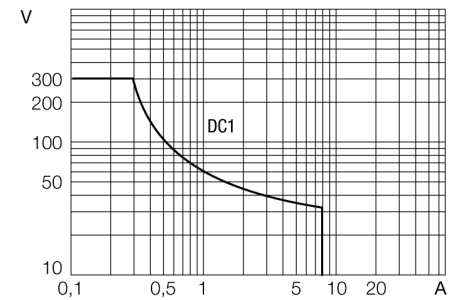
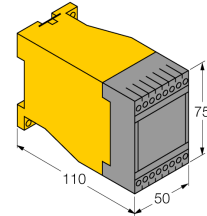

Output relay electrical lifetime

