

FEMALE END VIEW

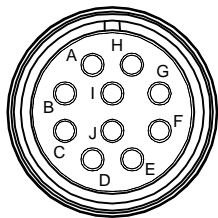

- A = YELLOW
- B = GRAY
- C = BLUE
- D = BROWN
- E = BLACK
- F = WHITE
- G = DRAIN
- H = PINK
- I = RED
- J = GREEN
- N/C = GRAY/PINK
- N/C = RD/BU
- N/C = VIOLET

CONNECTOR
 TYPE/STYLE/CLASS - MS 3106 E
 SHELL SIZE - 18
 INSERT ARRANGEMENT - 1

SPECIFICATIONS

CONTACT CARRIER MATERIAL	NEOPRENE
MOLDED HEAD MATERIAL/COLOR	TPU/BLACK
CONTACT MATERIAL/PLATING	COPPER ALLOY/SLIVER
COUPLING NUT MATERIAL/PLATING	ALUMINUM ALLOY/OLIVE DRAB CHROMATE
MOLD SLEEVE	BRASS/NICKEL
RATED CURRENT [A]	3.0 A
RATED VOLTAGE [V]	200 V
OUTER JACKET MATERIAL/COLOR	PVC/BLACK
CONDUCTOR INSULATION MATERIAL	PVC
NUMBER OF CONDUCTORS	12x24 AWG.
DRAIN/SHIELD	26 AWG DRAIN/FOIL AND BRAIDED SHIELD
TEMPERATURE RATING	-40°C to +105°C (-40°F to +221°F)
CONNECTOR TYPE	MIL-C-5015

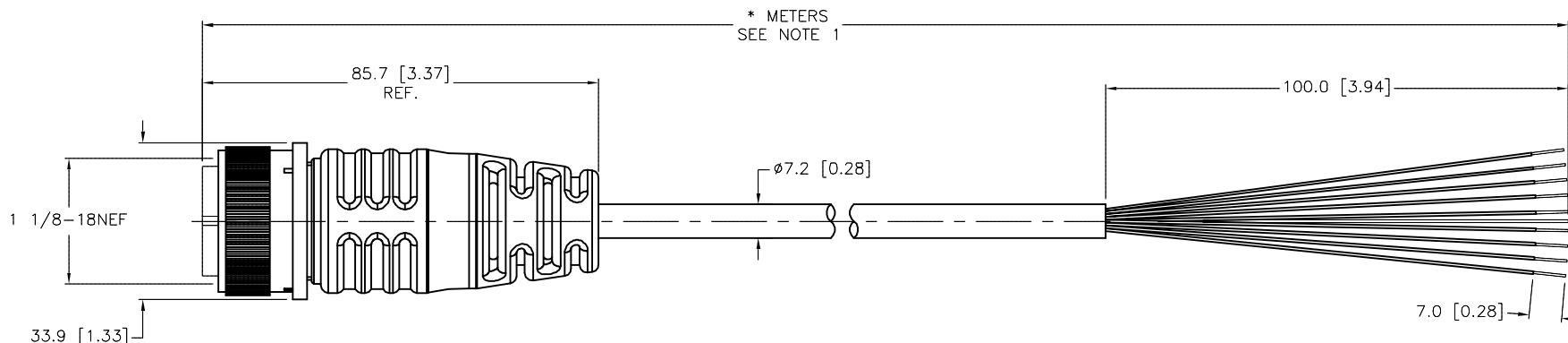

CABLE LENGTH	TOLERANCE*
ALL LENGTHS	+ 4% (OR 50mm) OF LENGTH - 0% (OR 0mm) OF LENGTH WHICHEVER IS GREATER
STRIP LENGTH	TOLERANCE*
0-7mm	±0.5mm
8-29mm	±1.0mm
30-49mm	±2.0mm
50-69mm	±3.0mm
70-100mm	±4.0mm
OVER 100mm	±5.0mm

* UNLESS OTHERWISE SPECIFIED

NOTES:

- "*" INDICATES CABLE LENGTH IN METERS. CONTACT TURCK TO ORDER SPECIFIC LENGTHS.
- "/CS11782" DESIGNATES CUSTOM PINOUT.

SOURCE DRAWING - FOR REFERENCE ONLY

RELATED DOCUMENTS 1. 2. 3. 4.	3RD ANGLE PROJECTION 	THIS DRAWING IS CONFIDENTIAL AND THE PROPERTY OF TURCK INC. USE OF THIS DOCUMENT WITHOUT WRITTEN PERMISSION IS PROHIBITED.		3000 CAMPUS DRIVE MINNEAPOLIS, MN 55441 1-800-544-7769 (763) 553-7300 (763) 553-0708 fax turck.com	
		DRFT RDS APVD DD	DATE 12/05/07 SCALE 1=1.5	DESCRIPTION MS 3106M-18-1S-931-*/CS11782	
MATERIAL SEE SPECIFICATIONS	ALL DIMENSIONS DISPLAYED ON THIS DRAWING ARE FOR REFERENCE ONLY	UNIT OF MEASUREMENT MILLIMETER [INCH]		DO NOT SCALE THIS DRAWING	
FINISH SEE SPECIFICATIONS		CONTACT TURCK FOR MORE INFORMATION		FILE: 777020690	

C	UPDATE CONDUCTOR COLORS	NF	10/08/15	51897
REV	DESCRIPTION	BY	DATE	ECO NO.