

REVISIONS			
REV	DESCRIPTION, ECN, EAR NO.	DATE	APP'D
A	PROPOSAL DRAWING (EAR 14575)	MAY15/18	A.G.
B	UPDATING COMMON TERMINOLOGY	MAY18/18	A.G.

NOTES:

- MATERIAL: ALL MATERIALS ARE RoHS COMPLIANT PER EU DIRECTIVE 2011/65/EU  
HOUSING & HEX NUT: THERMOPLASTIC PBT, UL FLAMMABILITY RATING 94V-0, BLACK  
CONTACT: COPPER ALLOY PLATED WITH GOLD FLASH OVER NICKEL  
DUST CAP: SILICONE RUBBER, BLACK
- ELECTRICAL CHARACTERISTICS:  
CURRENT RATING: 5A  
OPERATING VOLTAGE: 125V AC MAXIMUM  
DIELECTRIC WITHSTANDING VOLTAGE: 1500V DC  
CONTACT RESISTANCE: 10.0mΩ MAXIMUM.
- RECOMMENDED PANEL THICKNESS: 2.5 (0.098) TO 3.0 (0.118).
- ENVIRONMENTAL PROTECTION: IP67 PER IEC 60529 IN THE MATED AND UNMATED CONDITION.

ORDERING CODE: M R D - A X 0 3 - L 1 3 - 0 0 0

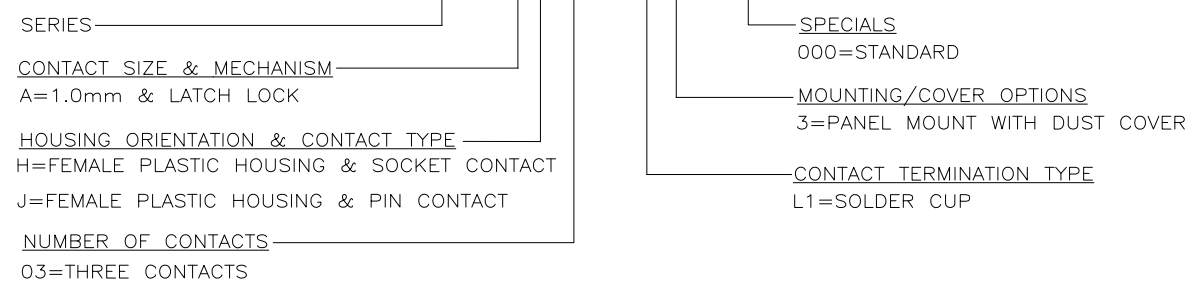

FEMALE WITH PIN CONTACT

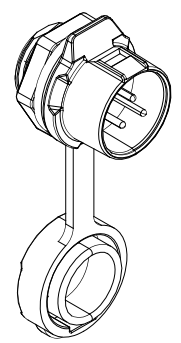

FEMALE WITH SOCKET CONTACT

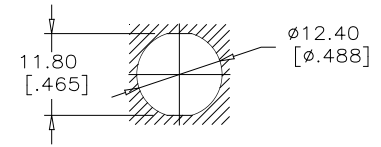
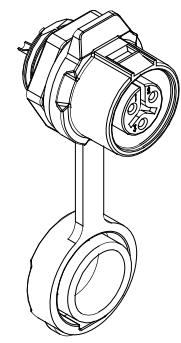

RECOMMENDED PANEL HOLE

SEE SHEET 2 FOR ADDITIONAL DRAWING VIEWS

PART NUMBER TABLE:

CONNECTOR PART NUMBER	CONTACT TYPE	WIRE GAUGE FOR SOLDER CUP
MRD-AH03-L13-000	SOCKET	20-24 AWG
MRD-AJ03-L13-000	PIN	18 AWG



UNLESS SPECIFIED OTHERWISE	DRAWN	K.XIONG	MAY09/18
PRIMARY UNITS MILLIMETERS	CHECKED	K.LAMBIE	MAY15/18
SECONDARY INCHES	M.E. APP'D		
REFERENCE IN PARENTHESES	Q.A. APP'D		
GENERAL TOLERANCES	DWG APP'D	A.GREEN	MAY15/18
1 DECIMAL PLACE ±0.25	ENG. REL. NO.		
2 DECIMAL PLACES ±0.15	REF.	EAR 14575	
3 DECIMAL PLACES ±0.05	THIRD ANGLE PROJECTION		
ANGULAR DEGREES	DO NOT SCALE DRAWING		

Amphenol Canada Corp. Commercial Products	
MRD SERIES RUGGED CONNECTOR, FEMALE, 3 POSITIONS, LATCH LOCK PANEL MOUNT WITH DUST COVER IP67 RATING, RoHS COMPLIANT	
DWG NO.	P-MRD-AX03-L13-000
CODE ID NO. 03554	DWG SIZE X SCALE XX:1 SHEET 1 OF 2

REVISIONS			
REV	DESCRIPTION, ECN, EAR NO.	DATE	APP'D
A	PROPOSAL DRAWING (EAR 14575)	TBD	A.G.
B	UPDATING COMMON TERMINOLOGY	MAY18/18	A.G.

FEMALE WITH PIN CONTACT

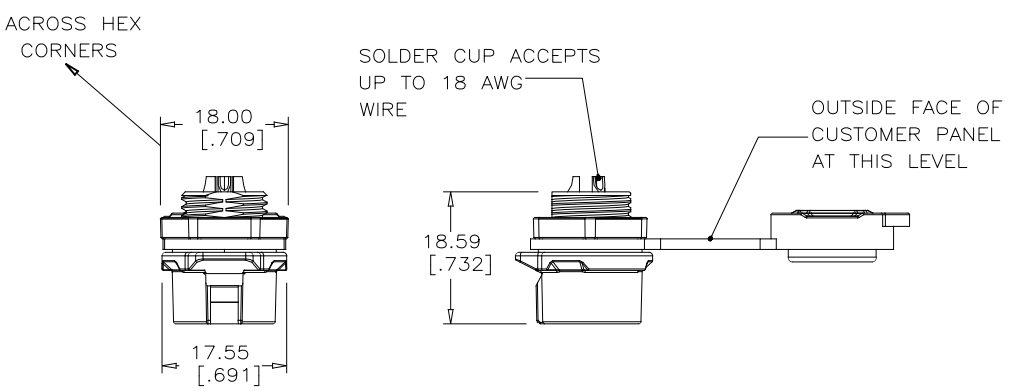

FEMALE WITH SOCKET CONTACT

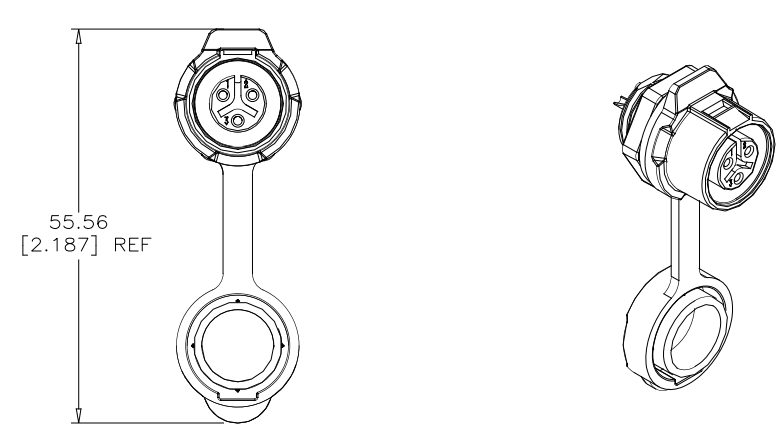
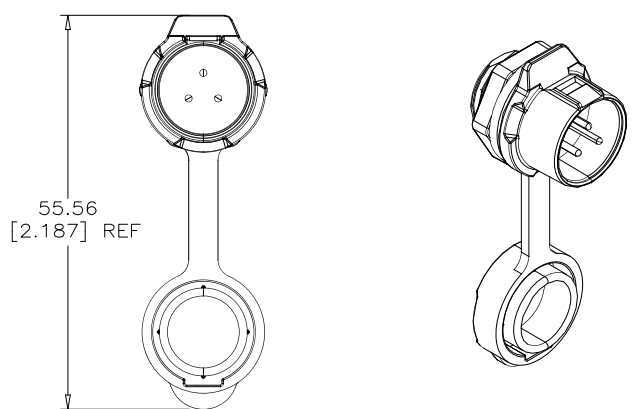
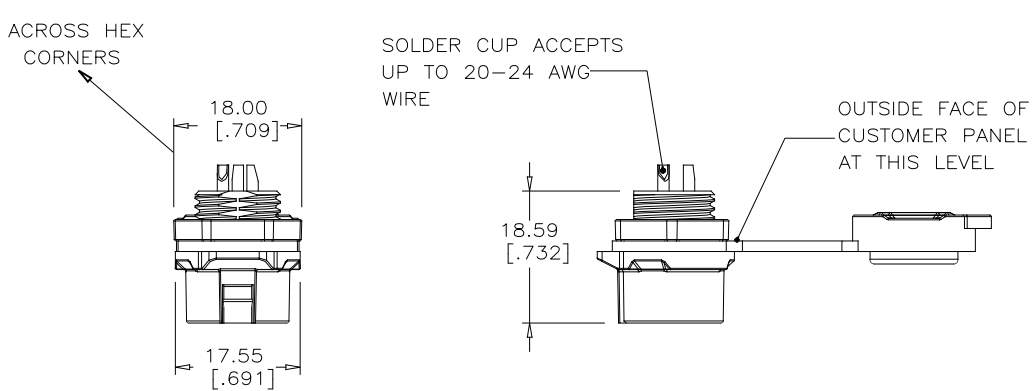

UNLESS SPECIFIED OTHERWISE	DRAWN	K.XIONG	MAY09/18
PRIMARY UNITS MILLIMETERS	CHECKED	K.LAMBIE	MAY15/18
SECONDARY INCHES	M.E. APP'D		
REFERENCE IN PARENTHESES	Q.A. APP'D		
GENERAL TOLERANCES	DWG APP'D	A.GREEN	MAY15/18
1 DECIMAL PLACE ±0.25	ENG. REL. NO.		
2 DECIMAL PLACES ±0.15	REF.	EAR 14575	
3 DECIMAL PLACES ±0.05	THIRD ANGLE PROJECTION		
ANGULAR DEGREES	DO NOT SCALE DRAWING		

Amphenol Canada Corp. Commercial Products	
MRD SERIES RUGGED CONNECTOR, FEMALE, 3 POSITIONS, LATCH LOCK PANEL MOUNT WITH DUST COVER IP67 RATING, RoHS COMPLIANT	
DWG NO. P-MRD-AX03-L13-000	REV B
CODE ID NO. 03554	DWG SIZE X SCALE XX:1 SHEET 2 OF 2

THIS DOCUMENT CONTAINS PROPRIETARY INFORMATION AND SUCH INFORMATION MAY NOT BE DISCLOSED TO OTHERS FOR ANY PURPOSE OR USED FOR MANUFACTURING PURPOSES WITHOUT WRITTEN PERMISSION FROM AMPHENOL CANADA CORP.