

**MR20H40** - 50MHz/20ns <sup>t</sup>SCK (Industrial Temp Range) 4Mb SPI Interface MRAM

**MR25H40** - 40MHz/25ns <sup>t</sup>SCK (Industrial, Extended and AEC-Q100 Grade 1 Temp Range) 4Mb SPI Interface MRAM

For more information on product options, see "Table 16 – Ordering Part Numbers" on page 24.

## FEATURES

- No write delays
- Unlimited write endurance
- Data retention greater than 20 years
- Automatic data protection on power loss
- Fast, simple SPI interface, up to 50 MHz clock rate with MR20H40.
- 3.0 to 3.6 Volt power supply range
- Low-current sleep mode
- Industrial (-40 to 85°C), Extended (-40 to 105°C), and AEC-Q100 Grade 1 (-40 to 125°C) temperature range options.
- Available in 8-pin DFN or 8-pin DFN Small Flag, RoHS-compliant packages.
- Direct replacement for serial EEPROM, Flash, and FeRAM
- MSL Level 3



8-DFN



8-DFN Small Flag



## DESCRIPTION

MR2xH40 is a family of 4,194,304-bit magnetoresistive random access memory (MRAM) devices organized as 524,288 words of 8 bits. They are the ideal memory solution for applications that must store and retrieve data and programs quickly using a small number of I/O pins. They have serial EEPROM and serial Flash compatible read/write timing with no write delays and unlimited read/write endurance. Unlike other serial memories, with the MR2xH40 family both reads and writes can occur randomly in memory with no delay between writes.

The MR2xH40 family provides highly reliable data storage over a wide range of temperatures. The MR20H40 (50MHz) is offered with Industrial (-40° to +85 °C) range. The MR25H40 (40MHz) is offered with Industrial (-40° to +85 °C), Extended (-40 to 105°C), and AEC-Q100 Grade 1 (-40°C to +125 °C) operating temperature range options.

Both are available in a 5 x 6mm, 8-pin DFN package. The pinout is compatible with serial SRAM, EEPROM, Flash, and FeRAM products.

## TABLE OF CONTENTS

<b>OVERVIEW .....</b>	<b>5</b>
Figure 1 – Block Diagram .....	5
<b>System Configuration .....</b>	<b>5</b>
Figure 2 – System Configuration.....	5
<b>Pin Functions .....</b>	<b>6</b>
Figure 3 – DFN Package Pin Diagram (Top View).....	6
Table 1 – Pin Functions.....	6
<b>SPI COMMUNICATIONS PROTOCOL.....</b>	<b>7</b>
<b>Command Codes.....</b>	<b>7</b>
Table 2 – Command Codes .....	7
<b>Status Register, Memory Protection and Block Write Protection.....</b>	<b>7</b>
Table 3 – Status Register Bit Assignments.....	7
<b>Memory Protection Modes .....</b>	<b>8</b>
Table 4 – Memory Protection Modes .....	8
<b>Block Protection Modes .....</b>	<b>8</b>
Table 5 – Block Memory Write Protection.....	8
<b>Read Status Register (RDSR).....</b>	<b>9</b>
Figure 4 – Read Status Register (RDSR) Timing.....	9
<b>Write Enable (WREN) .....</b>	<b>9</b>
Figure 5 – Write Enable (WREN) Timing.....	9
<b>Write Disable (WRDI).....</b>	<b>10</b>
Figure 6 – Write Disable (WRDI) Timing.....	10
<b>Write Status Register (WRSR) .....</b>	<b>10</b>
Figure 7 – Write Status Register (WRSR) Timing .....	10
<b>Read Data Bytes (READ) .....</b>	<b>11</b>
Figure 8 – Read Data Bytes (READ) Timing.....	11

## Table of Contents (Cont'd)

<b>Write Data Bytes (WRITE)</b> .....	<b>11</b>
Figure 9 – Write Data Bytes (WRITE) Timing.....	12
<b>Enter Sleep Mode (SLEEP)</b> .....	<b>12</b>
Figure 10 – Enter Sleep Mode (SLEEP) Timing.....	12
<b>Exit Sleep Mode (WAKE)</b> .....	<b>13</b>
Figure 11 – Exit Sleep Mode (WAKE) Timing.....	13
<b>ELECTRICAL SPECIFICATIONS</b> .....	<b>14</b>
<b>Absolute Maximum Ratings</b> .....	<b>14</b>
Table 6 – Absolute Maximum Ratings .....	14
Table 7 – Operating Conditions.....	15
Table 8 – DC Characteristics.....	15
Table 9 – Power Supply Characteristics .....	16
<b>TIMING SPECIFICATIONS</b> .....	<b>17</b>
<b>Capacitance</b> .....	<b>17</b>
Table 10 – Capacitance.....	17
<b>AC Measurement Conditions</b> .....	<b>17</b>
Table 11 – AC Measurement Conditions .....	17
Figure 12 – Output Load for Impedance Parameter Measurements .....	17
Figure 13 – Output Load for all Other Parameter Measurements.....	17
<b>Power Up Timing</b> .....	<b>18</b>
Table 12 – Power-Up Timing.....	18
Figure 14 – Power-Up Timing.....	18
<b>AC Timing Parameters</b> .....	<b>19</b>
Table 13 – MR20H40 ( $f_{SCK} = 50\text{MHz}$ ) AC Timing Parameters .....	19
Table 14 – MR25H40 ( $f_{SCK} = 40\text{MHz}$ ) AC Timing Parameters .....	20

## Table of Contents (Cont'd)

Figure 15 – Synchronous Data Timing.....	22
Figure 16 – $\overline{\text{HOLD}}$ Timing.....	22
<b>PART NUMBERS AND ORDERING .....</b>	<b>23</b>
Table 15 – Part Numbering System.....	23
Table 16 – Ordering Part Numbers.....	24
<b>PACKAGE OUTLINE DRAWINGS.....</b>	<b>25</b>
Figure 17 – DFN Package Outline .....	25
Figure 18 – DFN Small Flag Package.....	26
<b>HOW TO REACH US .....</b>	<b>28</b>

## OVERVIEW

The MR2xH40 family is an SPI interface MRAM family with a memory array logically organized as 512Kx8 using the four pin interface of chip select ( $\overline{CS}$ ), serial input (SI), serial output (SO) and serial clock (SCK) of the serial peripheral interface (SPI) bus. The MRAM implements a subset of commands common to SPI EEPROM and SPI Flash components. This allows the SPI MRAM to replace these components in the same socket and interoperate on a shared SPI bus. The SPI MRAM offers superior write speed, unlimited endurance, low standby & operating power, and simple, reliable data retention compared to other serial memory alternatives.

**Figure 1 – Block Diagram**

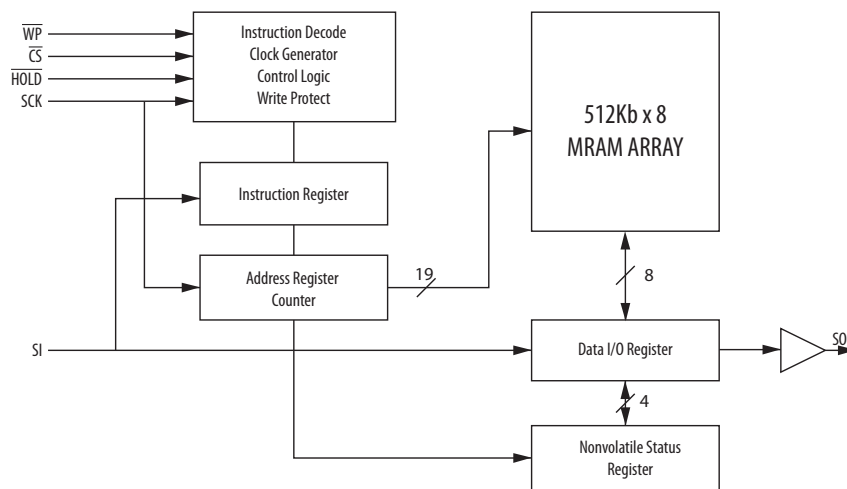

## System Configuration

Single or multiple devices can be connected to the bus as shown in Figure 2. Pins SCK, SO and SI are common among devices. Each device requires  $\overline{CS}$  and  $\overline{HOLD}$  pins to be driven separately.

**Figure 2 – System Configuration**

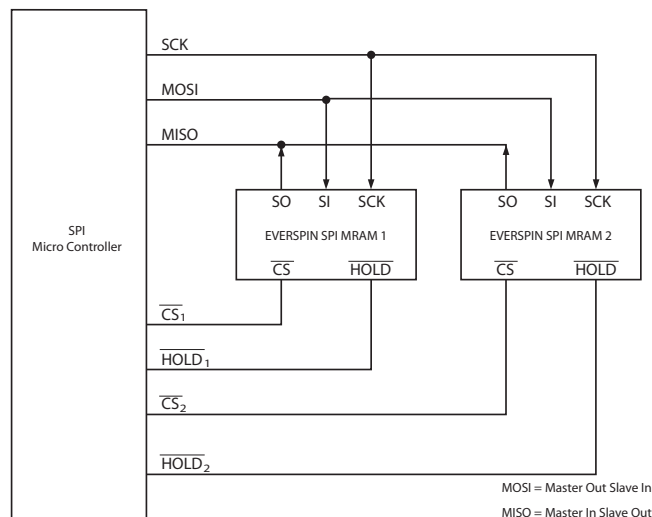

## Pin Functions

**Figure 3 – DFN Package Pin Diagram (Top View)**

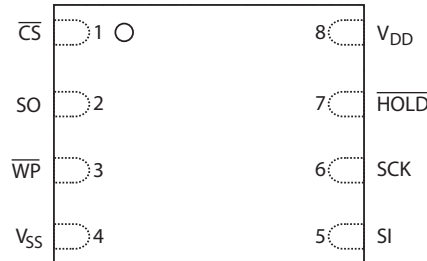

**Table 1 – Pin Functions**

Signal Name	Pin	I/O	Function	Description
$\overline{CS}$	1	Input	Chip Select	An active low chip select for the serial MRAM. When chip select is high, the memory is powered down to minimize standby power, inputs are ignored and the serial output pin is Hi-Z. Multiple serial memories can share a common set of data pins by using a unique chip select for each memory.
SO	2	Output	Serial Output	The data output pin is driven during a read operation and remains Hi-Z at all other times. SO is Hi-Z when HOLD is low. Data transitions on the data output occur on the falling edge of SCK.
$\overline{WP}$	3	Input	Write Protect	A low on the write protect input prevents write operations to the Status Register.
$V_{SS}$	4	Reference	Ground	Power supply ground pin.
SI	5	Input	Serial Input	All data is input to the device through this pin. This pin is sampled on the rising edge of SCK and ignored at other times. SI can be tied to SO to create a single bidirectional data bus if desired.
SCK	6	Input	Serial Clock	Synchronizes the operation of the MRAM. The clock can operate up to 50 MHz to shift commands, address, and data into the memory. Inputs are captured on the rising edge of clock. Data outputs from the MRAM occur on the falling edge of clock. The serial MRAM supports both SPI Mode 0 (CPOL=0, CPHA=0) and Mode 3 (CPOL=1, CPHA=1). In Mode 0, the clock is normally low. In Mode 3, the clock is normally high. Memory operation is static so the clock can be stopped at any time.
$\overline{HOLD}$	7	Input	Hold	A low on the Hold pin interrupts a memory operation for another task. When $\overline{HOLD}$ is low, the current operation is suspended. The device will ignore transitions on the $\overline{CS}$ and SCK when $\overline{HOLD}$ is low. All transitions of $\overline{HOLD}$ must occur while $\overline{CS}$ is low.
$V_{DD}$	8	Supply	Power Supply	Power supply voltage from +3.0 to +3.6 volts.

## SPI COMMUNICATIONS PROTOCOL

The MR2xH40 can be operated in either SPI Mode 0 (CPOL=0, CPHA =0) or SPI Mode 3 (CPOL=1, CPHA=1). For both modes, inputs are captured on the rising edge of the clock and data outputs occur on the falling edge of the clock. When not conveying data, SCK remains low for Mode 0; while in Mode 3, SCK is high. The memory determines the mode of operation (Mode 0 or Mode 3) based upon the state of the SCK when  $\overline{CS}$  falls.

All memory transactions start when  $\overline{CS}$  is brought low to the memory. The first byte is a command code. Depending upon the command, subsequent bytes of address are input. Data is either input or output. There is only one command performed per  $\overline{CS}$  active period.  $\overline{CS}$  must go inactive before another command can be accepted. To ensure proper part operation according to specifications, it is necessary to terminate each access by raising  $\overline{CS}$  at the end of a byte (a multiple of 8 clock cycles from  $\overline{CS}$  dropping) to avoid partial or aborted accesses.

### Command Codes

**Table 2 – Command Codes**

Instruction	Description	Binary Code	Hex Code	Address Bytes	Data Bytes
WREN	Write Enable	0000 0110	06h	0	0
WRDI	Write Disable	0000 0100	04h	0	0
RDSR	Read Status Register	0000 0101	05h	0	1
WRSR	Write Status Register	0000 0001	01h	0	1
READ	Read Data Bytes	0000 0011	03h	3	1 to ∞
WRITE	Write Data Bytes	0000 0010	02h	3	1 to ∞
SLEEP	Enter Sleep Mode	1011 1001	B9h	0	0
WAKE	Exit Sleep Mode	1010 1011	ABh	0	0

### Status Register, Memory Protection and Block Write Protection

The status register consists of the 8 bits listed in Table 3. As seen in Table 4, the Status Register Write Disable bit (SRWD) is used in conjunction with bit 1 (WEL) and the Write Protection pin ( $\overline{WP}$ ) to provide hardware memory block protection. Bits BP0 and BP1 define the memory block arrays that are protected as described in Table 5. The fast writing speed of the MR2xH40 does not require write status bits. The state of bits 6,5,4, and 0 can be user modified and do not affect memory operation. All bits in the status register are pre-set from the factory in the “0” state.

**Table 3 – Status Register Bit Assignments**

Bit 7	Bit 6	Bit 5	Bit 4	Bit 3	Bit 2	Bit 1	Bit 0
SRWD	Don't Care	Don't Care	Don't Care	BP1	BP0	WEL	Don't Care

## Memory Protection Modes

When WEL is reset to 0, writes to all blocks and the status register are protected. When WEL is set to 1, BP0 and BP1 determine which memory blocks are protected. While SRWD is reset to 0 and WEL is set to 1, status register bits BP0 and BP1 can be modified. Once SRWD is set to 1,  $\overline{WP}$  must be high to modify SRWD, BP0 and BP1.

**Table 4 – Memory Protection Modes**

WEL	SRWD	$\overline{WP}$	Protected Blocks	Unprotected Blocks	Status Register
0	X	X	Protected	Protected	Protected
1	0	X	Protected	Writable	Writable
1	1	Low	Protected	Writable	Protected
1	1	High	Protected	Writable	Writable

## Block Protection Modes

The memory enters hardware block protection when the  $\overline{WP}$  input is low and the Status Register Write Disable (SRWD) bit is set to 0. The memory leaves hardware block protection only when the  $\overline{WP}$  pin goes high. While  $\overline{WP}$  is low, the write protection blocks for the memory are determined by the status register bits BP0 and BP1 and cannot be modified without taking the  $\overline{WP}$  signal high again.

If the  $\overline{WP}$  signal is high (independent of the status of SRWD bit), the memory is in software protection mode. This means that block write protection is controlled solely by the status register BP0 and BP1 block write protect bits and this information can be modified using the WRSR command.

**Table 5 – Block Memory Write Protection**

Status Register		Memory Contents	
BP1	BP0	Protected Area	Unprotected Area
0	0	None	All Memory
0	1	Upper Quarter	Lower Three-Quarters
1	0	Upper Half	Lower Half
1	1	All	None

## Read Status Register (RDSR)

The Read Status Register (RDSR) command allows the Status Register to be read. The Status Register can be read at any time to check the status of write enable latch bit, status register write protect bit, and block write protect bits. For MR2xH40, the write in progress bit (bit 0) is not written by the memory because there is no write delay. The RDSR command is entered by driving  $\overline{CS}$  low, sending the command code, and then driving  $\overline{CS}$  high.

**Figure 4 – Read Status Register (RDSR) Timing**

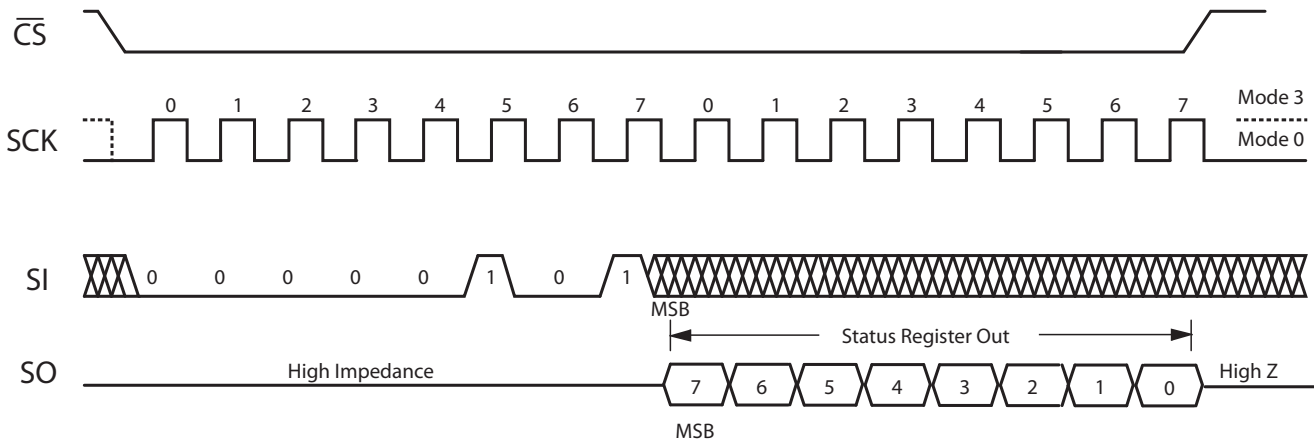

## Write Enable (WREN)

The Write Enable (WREN) command sets the Write Enable Latch (WEL) bit in the status register (bit 1). The Write Enable Latch must be set prior to writing either bit in the status register or the memory. The WREN command is entered by driving  $\overline{CS}$  low, sending the command code, and then driving  $\overline{CS}$  high.

**Figure 5 – Write Enable (WREN) Timing**

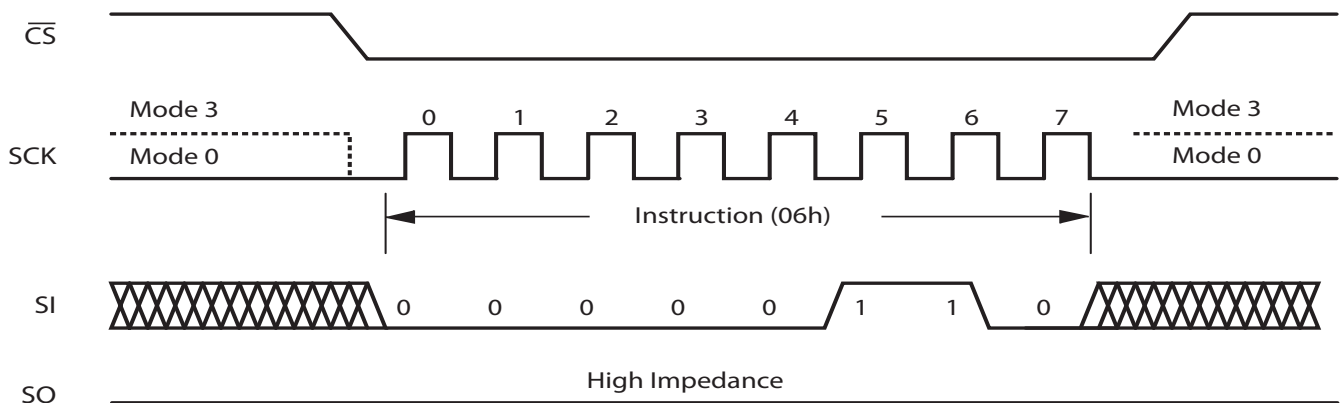

## Write Disable (WRDI)

The Write Disable (WRDI) command resets the Write Enable Latch (WEL) bit in the status register (bit 7) to 0. This prevents writes to status register or memory. The WRDI command is entered by driving  $\overline{CS}$  low, sending the command code, and then driving  $\overline{CS}$  high.

The Write Enable Latch (WEL) is reset to 0 on power-up or when the WRDI command is completed.

**Figure 6 – Write Disable (WRDI) Timing**

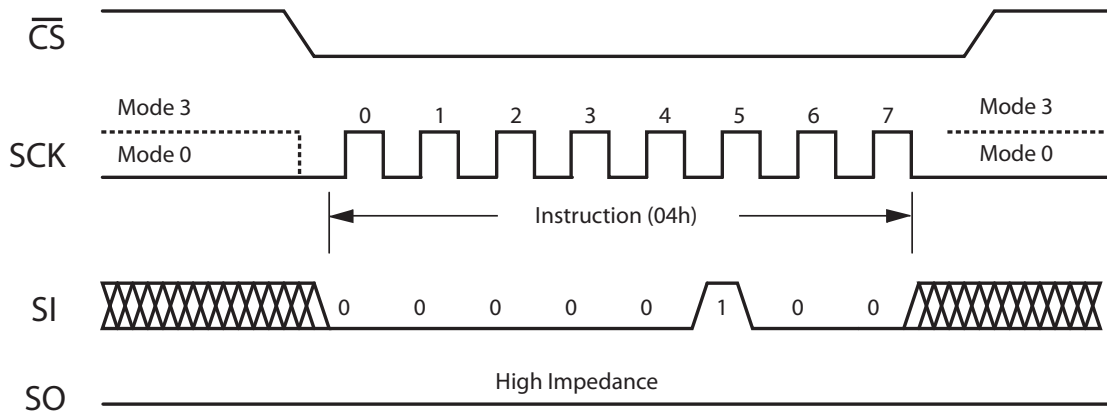

## Write Status Register (WRSR)

The Write Status Register (WRSR) command allows new values to be written to the Status Register. The WRSR command is not executed unless the Write Enable Latch (WEL) has been set to 1 by executing a WREN command while pin  $\overline{WP}$  and bit SRWD correspond to values that make the status register writable as seen in Table 4 on page 8. Status Register bits are non-volatile with the exception of the WEL which is reset to 0 upon power cycling.

The WRSR command is entered by driving  $\overline{CS}$  low, sending the command code and status register write data byte, and then driving  $\overline{CS}$  high.

**Figure 7 – Write Status Register (WRSR) Timing**

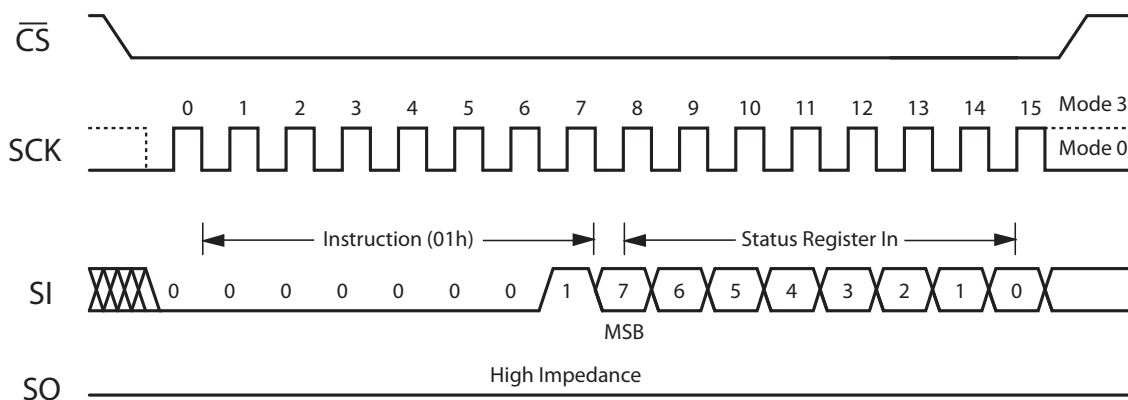

## Read Data Bytes (READ)

The Read Data Bytes (READ) command allows data bytes to be read starting at an address specified by the 24-bit address. Only address bits 0-18 are decoded by the memory. The data bytes are read out sequentially from memory until the read operation is terminated by bringing  $\overline{CS}$  high. The entire memory can be read in a single command. The address counter will roll over to 0000H when the address reaches the top of memory.

The READ command is entered by driving  $\overline{CS}$  low and sending the command code. The memory drives the read data bytes on the SO pin. Reads continue as long as the memory is clocked. The command is terminated by bringing  $\overline{CS}$  high.

**Figure 8 – Read Data Bytes (READ) Timing**

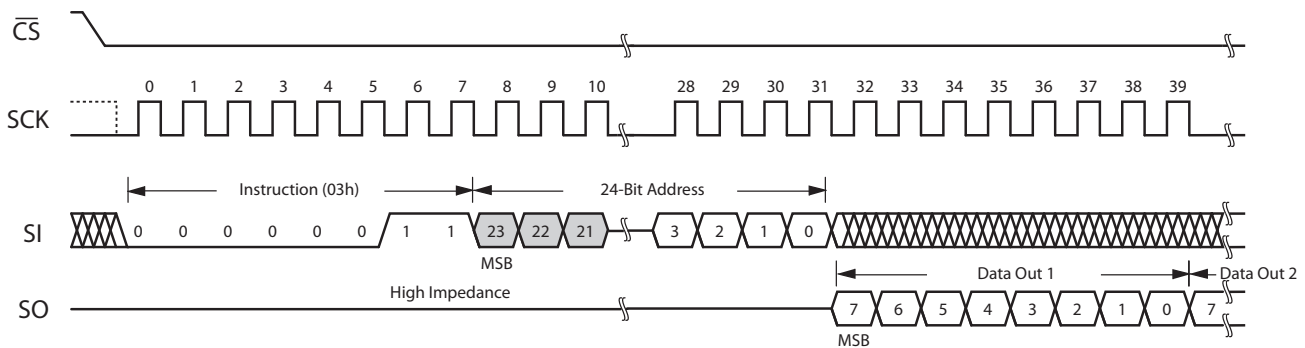

## Write Data Bytes (WRITE)

The Write Data Bytes (WRITE) command allows data bytes to be written starting at an address specified by the 24-bit address. Only address bits 0-18 are decoded by the memory. The data bytes are written sequentially in memory until the write operation is terminated by bringing  $\overline{CS}$  high. The entire memory can be written in a single command. The address counter will roll over to 0000H when the address reaches the top of memory.

Unlike EEPROM or Flash Memory, MRAM can write data bytes continuously at its maximum rated clock speed without write delays or data polling. Back to back WRITE commands to any random location in memory can be executed without write delay. MRAM is a random access memory rather than a page, sector, or block organized memory so it is ideal for both program and data storage.

The WRITE command is entered by driving  $\overline{CS}$  low, sending the command code, and then sequential write data bytes. Writes continue as long as the memory is clocked. The command is terminated by bringing  $\overline{CS}$  high.

**Figure 9 – Write Data Bytes (WRITE) Timing**

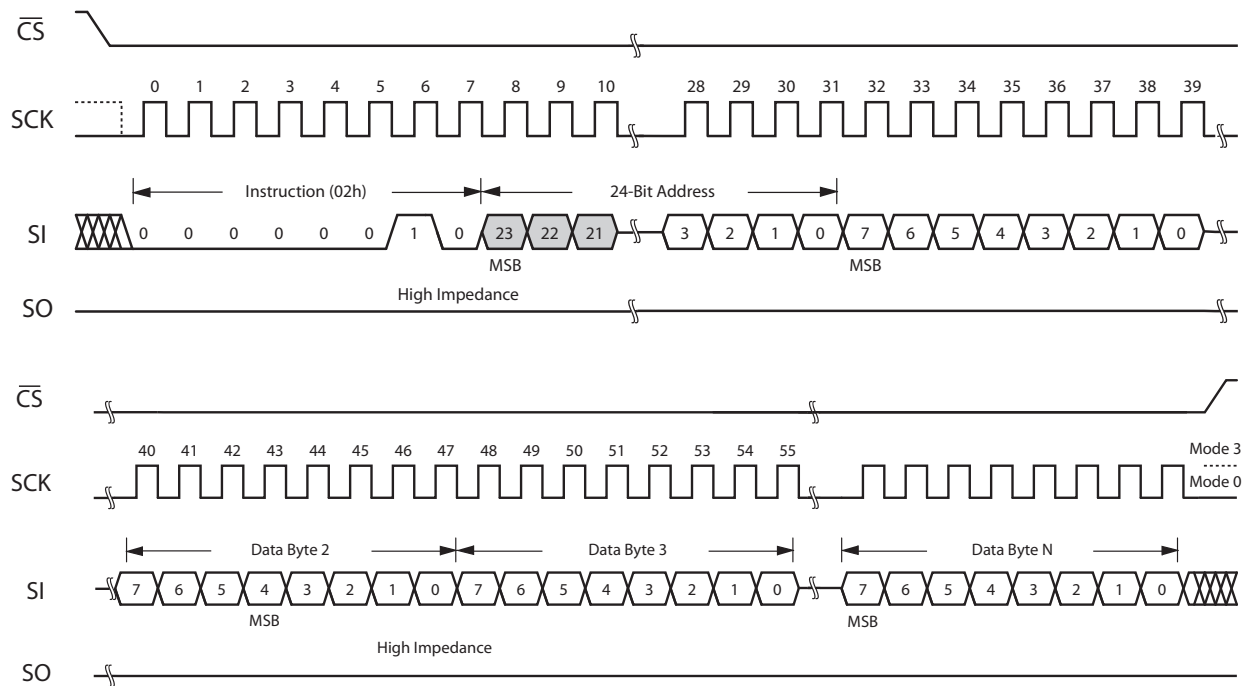

## Enter Sleep Mode (SLEEP)

The Enter Sleep Mode (SLEEP) command turns off all MRAM power regulators in order to reduce the overall chip standby power to 15  $\mu$ A typical. The SLEEP command is entered by driving  $\overline{CS}$  low, sending the command code, and then driving  $\overline{CS}$  high. The standby current is achieved after time,  $t_{DP}$ . If power is removed when the part is in sleep mode, upon power restoration, the part enters normal standby. The only valid command following SLEEP mode entry is a WAKE command.

**Figure 10 – Enter Sleep Mode (SLEEP) Timing**

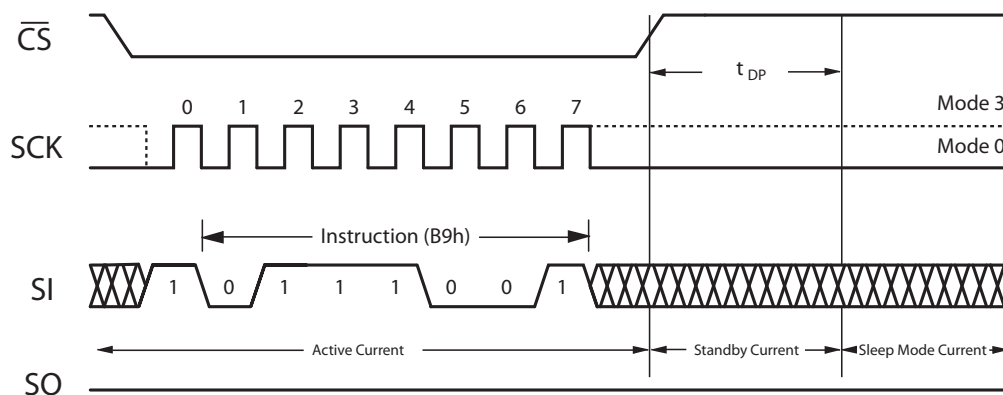

## Exit Sleep Mode (WAKE)

The Exit Sleep Mode (WAKE) command turns on internal MRAM power regulators to allow normal operation. The WAKE command is entered by driving  $\overline{CS}$  low, sending the command code, and then driving  $\overline{CS}$  high. The memory returns to standby mode after  $t_{RDP}$ . The  $\overline{CS}$  pin must remain high until the  $t_{RDP}$  period is over. WAKE must be executed after sleep mode entry and prior to any other command.

**Figure 11 – Exit Sleep Mode (WAKE) Timing**

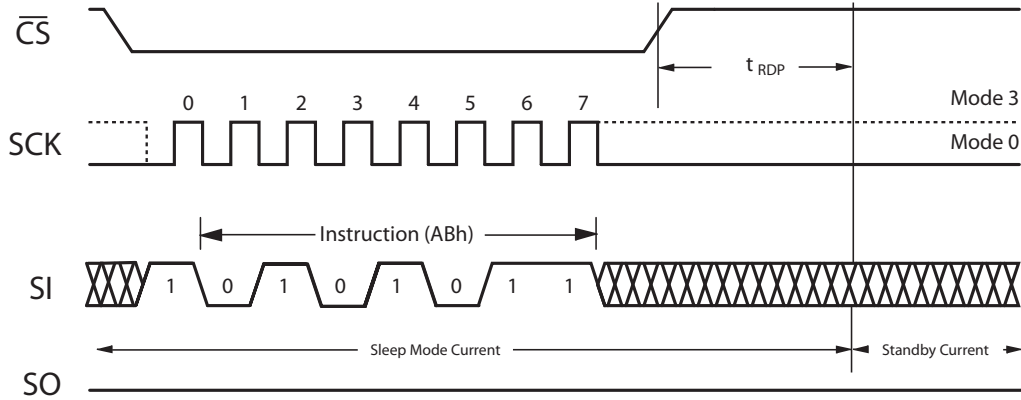

## ELECTRICAL SPECIFICATIONS

### Absolute Maximum Ratings

This device contains circuitry to protect the inputs against damage caused by high static voltages or electric fields. However, it is advised that normal precautions be taken to avoid application of any voltage greater than maximum rated voltages to these high-impedance (Hi-Z) circuits.

The device also contains protection against external magnetic fields. Precautions should be taken to avoid application of any magnetic field more intense than the maximum field intensity specified in the maximum ratings.

**Table 6 – Absolute Maximum Ratings**

Permanent device damage may occur if absolute maximum ratings are exceeded. Functional operation should be restricted to recommended operating conditions. Exposure to excessive voltages or magnetic fields could affect device reliability.

Symbol	Parameter	Conditions	Value	Unit
$V_{DD}$	Supply voltage <sup>2</sup>		-0.5 to 4.0	V
$V_{IN}$	Voltage on any pin <sup>2</sup>		-0.5 to $V_{DD} + 0.5$	V
$I_{OUT}$	Output current per pin		±20	mA
$P_D$	Package power dissipation <sup>3</sup>		0.600	W
$T_{BIAS}$	Temperature under bias	Commercial	-45 to 95	°C
		Industrial	-45 to 95	°C
		Extended	-45 to 115	°C
		AEC-Q100 Grade 1	-45 to 135	°C
$T_{stg}$	Storage Temperature		-55 to 150	°C
$T_{Lead}$	Lead temperature during solder (3 minute max)		260	°C
$H_{max\_write}$	Maximum magnetic field during write	Write	12,000	A/m
$H_{max\_read}$	Maximum magnetic field during read or standby	Read or Standby	12,000	A/m

#### Notes:

1. All voltages are referenced to  $V_{SS}$ . The DC value of  $V_{IN}$  must not exceed actual applied  $V_{DD}$  by more than 0.5V. The AC value of  $V_{IN}$  must not exceed applied  $V_{DD}$  by more than 2V for 10ns with  $I_{IN}$  limited to less than 20mA.
2. Power dissipation capability depends on package characteristics and use environment.

### Table 7 – Operating Conditions

Symbol	Parameter	Temp Grade	Min	Max	Unit
$V_{DD}$	Power supply voltage		3.0	3.6	V
$V_{IH}$	Input high voltage		2.2	$V_{DD} + 0.3$	V
$V_{IL}$	Input low voltage		-0.5	0.8	V
$T_A$	Ambient temperature under bias	Commercial	0	70	°C
		Industrial	-40	85	°C
		Extended	-40	105	°C
		AEC-Q100 Grade 1 <sup>1</sup>	-40	125	°C

Notes:

1. AEC-Q100 Grade 1 temperature profile assumes 10 percent duty cycle at maximum temperature (2 years out of 20-year life.)

### Table 8 – DC Characteristics

Symbol	Parameter	Conditions	Min	Max	Unit
$I_{LI}$	Input leakage current		-	$\pm 1$	$\mu A$
$I_{LO}$	Output leakage current		-	$\pm 1$	$\mu A$
$V_{OL}$	Output low voltage	$I_{OL} = +4 \text{ mA}$	-	0.4	V
		$I_{OL} = +100 \mu A$	-	$V_{SS} + 0.2v$	V
$V_{OH}$	Output high voltage	$I_{OH} = -4 \text{ mA}$	2.4	-	V
		$I_{OH} = -100 \mu A$	$V_{DD} - 0.2$	-	V

## Table 9 – Power Supply Characteristics

Symbol	Parameter	Conditions	Typical	Max	Unit
$I_{DDR}$	Active Read Current	@ 1 MHz	5.0	11	mA
		@ 40 MHz	12	17	mA
		@ 50MHz	13.8	18.5	mA
$I_{DDW}$	Active Write Current	@ 1 MHz	9.0	25	mA
		@ 40 MHz	28	42	mA
		@ 50 MHz	33	46.5	mA
$I_{SB1}$	AC Standby Current (CS High)	@ 40 MHz	250	400	$\mu$ A
		@ 50 MHz	650	750	$\mu$ A
$I_{SB2}$	CMOS Standby Current (CS High)		90	180	$\mu$ A
$I_{ZZ}$	Standby Sleep Mode Current (CS High)		15	40	$\mu$ A

## TIMING SPECIFICATIONS

### Capacitance

**Table 10 – Capacitance**

Symbol	Parameter	Typical	Max	Unit
$C_{In}$	Control input capacitance <sup>1</sup>	-	6	pF
$C_{I/O}$	Input/Output capacitance <sup>1</sup>	-	8	pF

Notes:

- $f = 1.0$  MHz,  $dV = 3.0$  V,  $T_A = 25$  °C, periodically sampled rather than 100% tested.

### AC Measurement Conditions

**Table 11 – AC Measurement Conditions**

Parameter	Value	Unit
Logic input timing measurement reference level	1.5	V
Logic output timing measurement reference level	1.5	V
Logic input pulse levels	0 or 3.0	V
Input rise/fall time	2	ns
Output load for low and high impedance parameters	See Figure 12	
Output load for all other timing parameters	See Figure 13	

**Figure 12 – Output Load for Impedance Parameter Measurements**

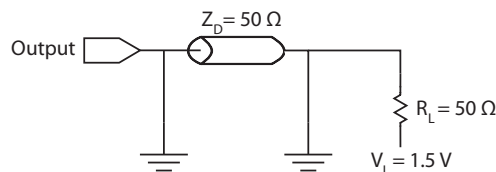

**Figure 13 – Output Load for all Other Parameter Measurements**

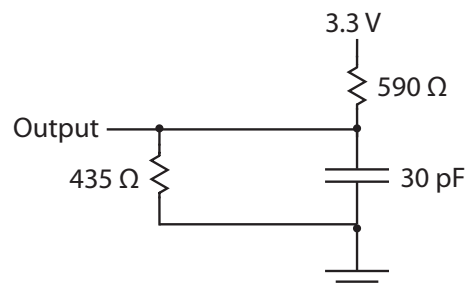

## Power Up Timing

The MR2xH40 is not accessible for a start-up time,  $t_{PU} = 400 \mu s$  after power up. Users must wait this time from the time when  $V_{DD}(\min)$  is reached until the first  $\overline{CS}$  low to allow internal voltage references to become stable. The  $\overline{CS}$  signal should be pulled up to  $V_{DD}$  so that the signal tracks the power supply during power-up sequence.

**Table 12 – Power-Up Timing**

Symbol	Parameter	Min	Typical	Max	Unit
$V_{WI}$	Write Inhibit Voltage	2.2	-	-	V
$t_{PU}$	Startup Time	400	-	-	$\mu s$

**Figure 14 – Power-Up Timing**

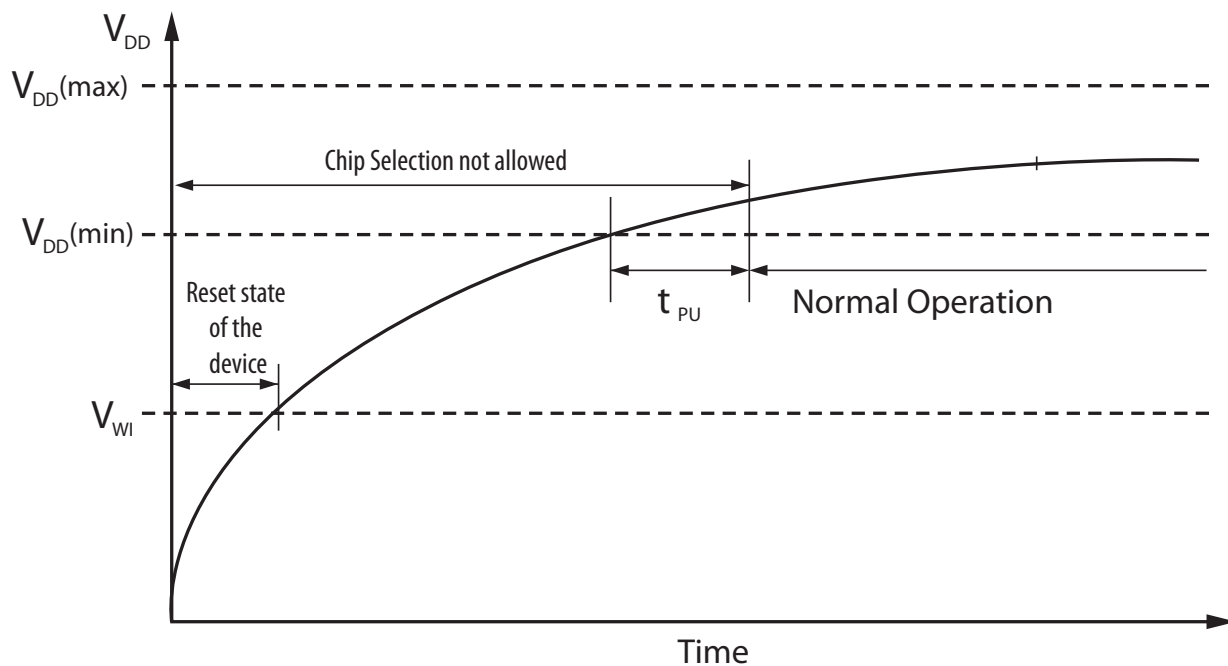

## AC Timing Parameters

**Table 13 – MR20H40 (f<sub>SCK</sub> = 50MHz) AC Timing Parameters**

Industrial Temperature Range, V<sub>DD</sub>=3.0 to 3.6 V, C<sub>L</sub>= 30 pF for all values.

Symbol	Parameter	Temp Range	Min	Typical	Max	Unit
f <sub>SCK</sub>	SCK Clock Frequency	Industrial	0	-	50	MHz
t <sub>RI</sub>	Input Rise Time	Industrial	-	-	50	ns
t <sub>RF</sub>	Input Fall Time	Industrial	-	-	50	ns
t <sub>WH</sub>	SCK High Time	Industrial	7	-	-	ns
t <sub>WL</sub>	SCK Low Time	Industrial	7	-	-	ns
<b>Synchronous Data Timing see Figure 15</b>						
t <sub>CS</sub>	CS High Time	Industrial	40	-	-	ns
t <sub>CSS</sub>	CS Setup Time	Industrial	5	-	-	ns
t <sub>CSH</sub>	CS Hold Time	Industrial	5	-	-	ns
t <sub>SU</sub>	Data In Setup Time	Industrial	2	-	-	ns
t <sub>H</sub>	Data In Hold Time	Industrial	5	-	-	ns
t <sub>V</sub>	Output Valid	Industrial	0	-	9	ns
t <sub>HO</sub>	Output Hold Time	Industrial	0	-	-	ns
<b>HOLD Timing see Figure 16</b>						
t <sub>HD</sub>	HOLD Setup Time	Industrial	5	-	-	ns
t <sub>CD</sub>	HOLD Hold Time	Industrial	5	-	-	ns
t <sub>LZ</sub>	HOLD to Output Low Impedance	Industrial	-	-	20	ns
t <sub>HZ</sub>	HOLD to Output High Impedance	Industrial	-	-	20	ns
<b>Other Timing Specifications</b>						
t <sub>WPS</sub>	WP Setup To CS Low	Industrial	5	-	-	ns
t <sub>WPH</sub>	WP Hold From CS High	Industrial	5	-	-	ns
t <sub>DP</sub>	Sleep Mode Entry Time	Industrial	3	-	-	μs
t <sub>RDP</sub>	Sleep Mode Exit Time	Industrial	400	-	-	μs
t <sub>DIS</sub>	Output Disable Time	Industrial	12	-	-	ns

**Table 14 – MR25H40 (f<sub>SCK</sub> = 40MHz) AC Timing Parameters**

Industrial, Extended and AEC-Q100 Grade 1 Temperature Ranges, V<sub>DD</sub>=3.0 to 3.6 V, C<sub>L</sub>= 30 pF for all values.

Symbol	Parameter	Temp Grade	Min	Typical	Max	Unit
f <sub>SCK</sub>	SCK Clock Frequency	All	0	-	40	MHz
t <sub>RI</sub>	Input Rise Time	All	-	-	50	ns
t <sub>RF</sub>	Input Fall Time	All	-	-	50	ns
t <sub>WH</sub>	SCK High Time	All	11	-	-	ns
t <sub>WL</sub>	SCK Low Time	All	11	-	-	ns
<b>Synchronous Data Timing see Figure 15</b>						
t <sub>CS</sub>	CS High Time	All	40	-	-	ns
t <sub>CSS</sub>	CS Setup Time	All	10	-	-	ns
t <sub>CSH</sub>	CS Hold Time	All	10	-	-	ns
t <sub>SU</sub>	Data In Setup Time	All	5	-	-	ns
t <sub>H</sub>	Data In Hold Time	All	5	-	-	ns
t <sub>V</sub>	Output Valid	Industrial/Extended	0	-	9	ns
		AEC-Q100 Grade 1	0	-	10	ns
t <sub>HO</sub>	Output Hold Time	All	0	-	-	ns

Table continues next page.

## Table 14 (Cont'd) - MR25H40 (f<sub>SCK</sub> = 40MHz) AC Timing Parameters

Industrial, Extended and AEC-Q100 Grade 1 Temperature Ranges, V<sub>DD</sub>=3.0 to 3.6 V, C<sub>L</sub>= 30 pF for all values.

<b>HOLD Timing see Figure 16</b>						
<b>Symbol</b>	<b>Parameter</b>	<b>Temp Grade</b>	<b>Min</b>	<b>Typical</b>	<b>Max</b>	<b>Unit</b>
t <sub>HD</sub>	HOLD Setup Time	All	10	-	-	ns
t <sub>CD</sub>	HOLD Hold Time	All	10	-	-	ns
t <sub>LZ</sub>	HOLD to Output Low Impedance	All	-	-	20	ns
t <sub>HZ</sub>	HOLD to Output High Impedance	All	-	-	20	ns
<b>Other Timing Specifications</b>						
t <sub>WPS</sub>	WP Setup To CS Low	All	5	-	-	ns
t <sub>WPH</sub>	WP Hold From CS High	All	5	-	-	ns
t <sub>DP</sub>	Sleep Mode Entry Time	All	3	-	-	μs
t <sub>RDP</sub>	Sleep Mode Exit Time	All	400	-	-	μs
t <sub>DIS</sub>	Output Disable Time	All	12	-	-	ns

**Figure 15 – Synchronous Data Timing**

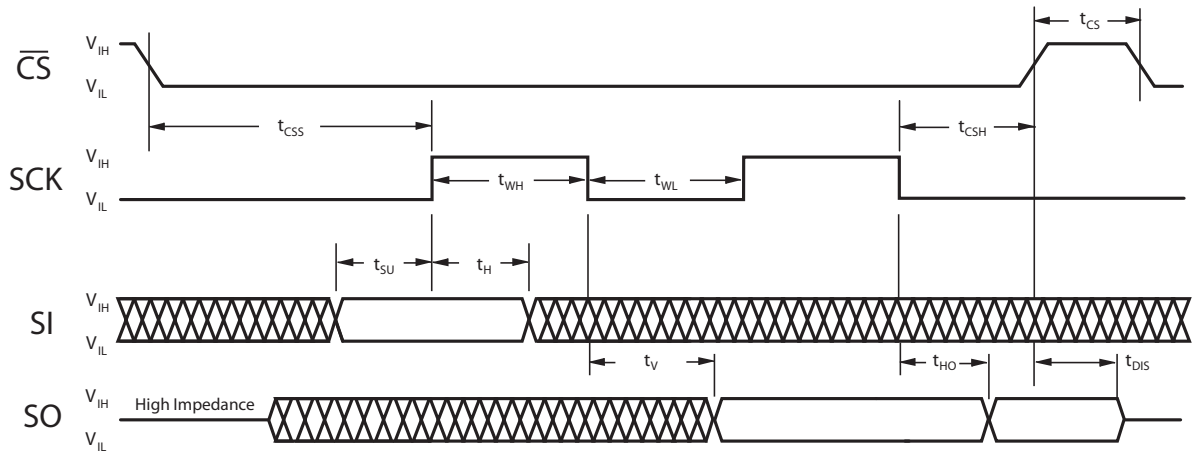

**Figure 16 –  $\overline{HOLD}$  Timing**

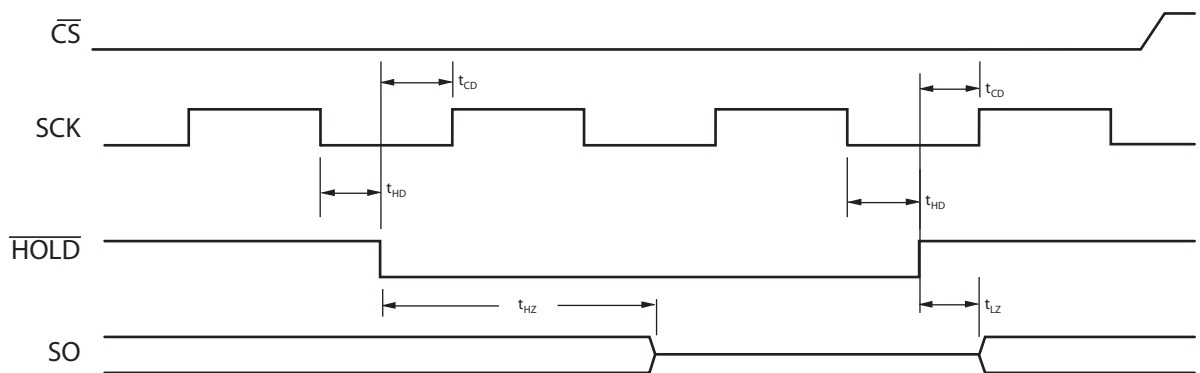

## PART NUMBERS AND ORDERING

### Table 15 – Part Numbering System

Product Family Number		MR	25H	40				
Ordering Part Number		Memory	Interface	Density	Revision	Temp	Package	Grade
		MR	25H	40		C	DC	ES
MRAM	MR							
50 MHz Serial Family	20H							
40 MHz Serial Family	25H							
256 Kb	256							
512 Kb	512							
1 Mb	10							
4 Mb	40							
No Revision	Blank							
Revision A	A							
Revision B	B							
Commercial	0 to 70°C	Blank						
Industrial	-40 to 85°C	C						
Extended	-40 to 105°C	V						
AEC Q-100 Grade 1	-40 to 125°C	M						
8-pin DFN in Tray	DC							
8-pin DFN Tape and Reel	DCR							
8-pin DFN (small flag) in Tray	DF							
8-pin DFN (small flag) Tape and Reel	DFR							
Engineering Samples	ES							
Customer Samples	Blank							
Mass Production	Blank							

Product Family Number and Ordering Part Number given are for illustration only.

**Table 16 – Ordering Part Numbers**

Speed Grade	Temp Grade	Temperature	Package	Shipping Container	Order Part Number
50MHz	Industrial	-40 to +85 C	8-DFN Small Flag	Trays	MR20H40CDF
				Tape and Reel	MR20H40CDFR
40 MHz	Industrial	-40 to +85 C	8-DFN	Trays	MR25H40CDC
				Tape and Reel	MR25H40CDCR
			8-DFN Small Flag	Trays	MR25H40CDF
				Tape and Reel	MR25H40CDFR
	Extended	-40 to +105 C	8-DFN Small Flag	Trays	MR25H40VDF
				Tape and Reel	MR25H40VDFR
	AEC-Q100 Grade 1	-40 to +125 C	8-DFN Small Flag	Trays	MR25H40MDF
				Tape and Reel	MR25H40MDFR

## PACKAGE OUTLINE DRAWINGS

**Figure 17 – DFN Package Outline**

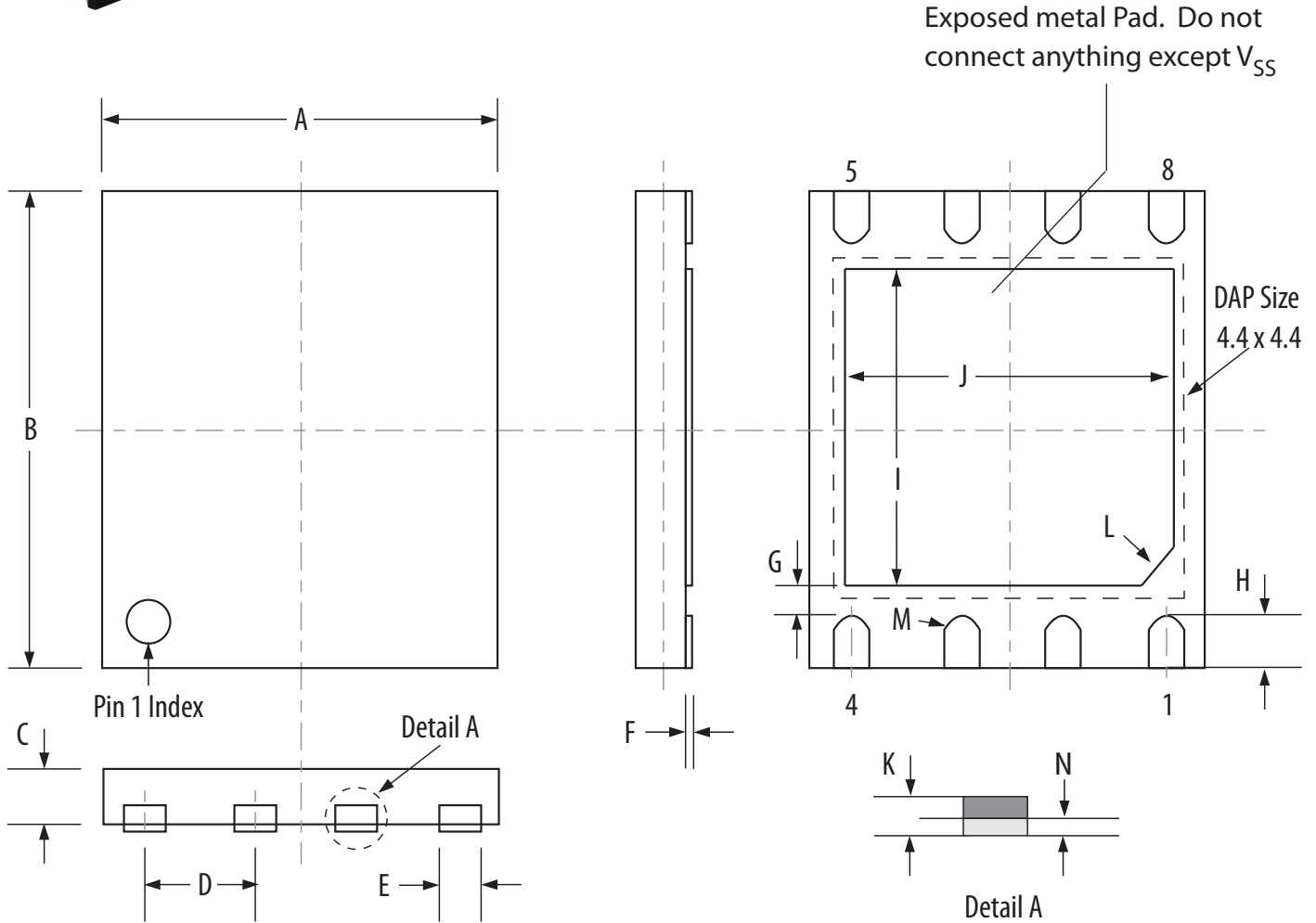

Dimension	A	B	C	D	E	F	G	H	I	J	K	L	M	N
Max.	5.10	6.10	1.00	1.27	0.45	0.05	0.35 Ref.	0.70	4.20	4.20	0.261	C0.35	R0.20	0.05
Min.	4.90	5.90	0.90	BSC	0.35	0.00		0.50	4.00	4.00	0.195			0.00

**Notes:**

1. Reference JEDEC MO-229.
2. All dimensions are in mm. Angles in degrees.
3. Coplanarity applies to the exposed pad as well as the terminals. Coplanarity shall be within 0.08 mm.
4. Warpage shall not exceed 0.10 mm.



**Figure 18 – DFN Small Flag Package**

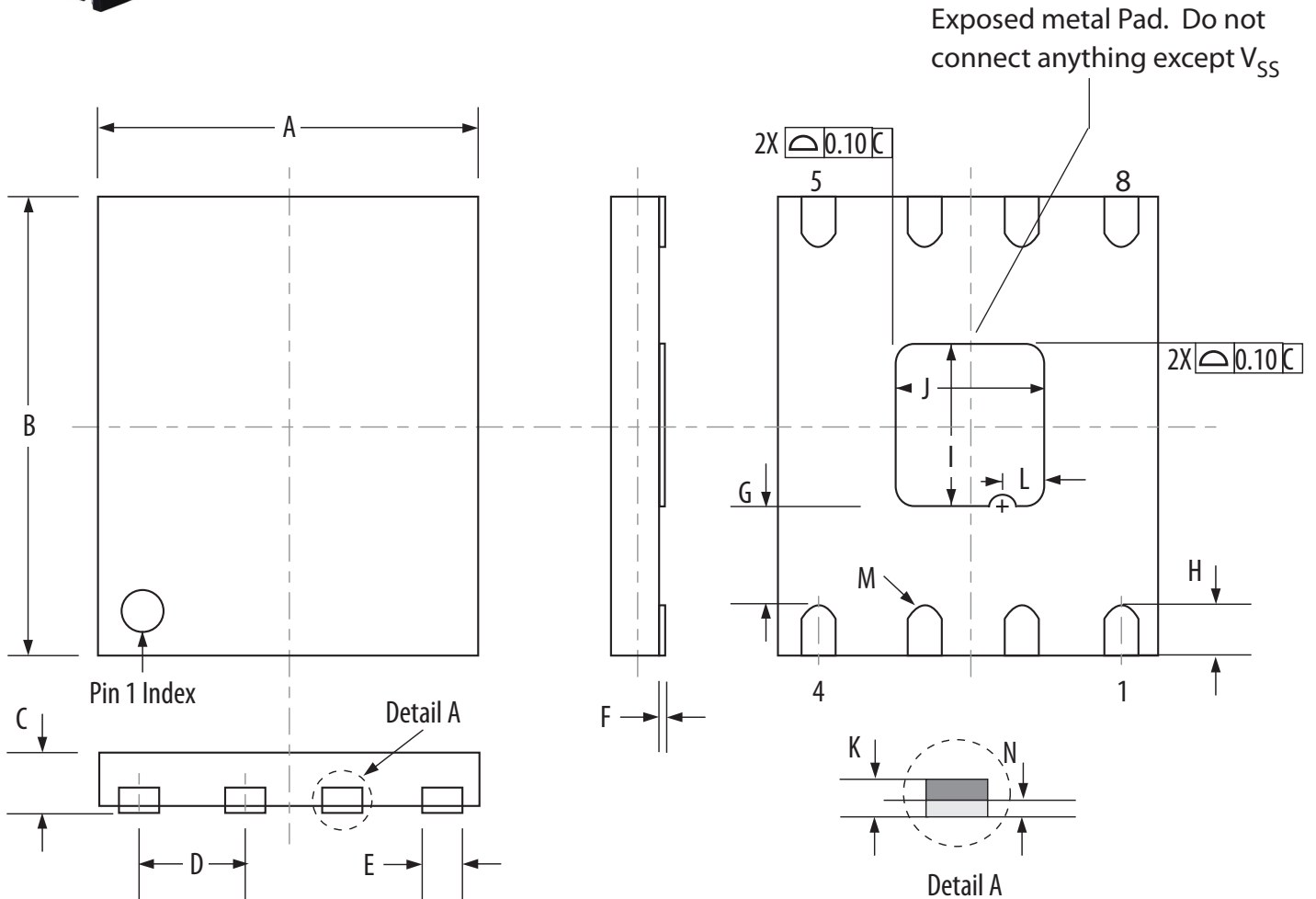

Dimension	A	B	C	D	E	F	G	H	I	J	K	L	M	N
Max.	5.10	6.10	0.90	1.27 BSC	0.45	0.05	1.60	0.70	2.10	2.10	.210	C0.45	R0.20	0.05
Min.	4.90	5.90	0.80		0.35	0.00	1.20	0.50	1.90	1.90	.196			0.00

**Notes:**

1. Reference JEDEC MO-229.
2. All dimensions are in mm. Angles in degrees.
3. Coplanarity applies to the exposed pad as well as the terminals. Coplanarity shall be within 0.08 mm.
4. Warpage shall not exceed 0.10 mm.

## REVISION HISTORY

Revision	Date	Description of Change
0	Jan 15, 2010	Product Concept Release
0.1	Feb. 23, 2010	Fixed typos in text.
1	May 5, 2010	Removed commercial specifications. All parts meet industrial specifications.
2	Jan 11, 2011	Preliminary Product Release. Updated description of status register non-volatility, WAKE command, Table 3.4.
3	Apr 25, 2011	Removed DIP package part to separate datasheet. Added inset detail for mechanical package drawings.
4	September 22, 2011	Added AEC-Q100 Grade 1 ordering option. Revised Table 3.1, Table 3.2, Table 3.4, Table 4.4 revised and Note 2 deleted, revised Figure 5.1 and Table 5.1.
5	Nov 18, 2011	Corrected $V_{OL}$ in Table 3.3 to read $V_{OL} \text{ Max} = V_{SS} + 0.2v$ . Corrected SI waveform in Figure 2.8. New Small Flag DFN package option added to Page 1 Features and available parts Table 5.1. DFN Small Flag drawing and dimensions table added as Figure 6.2. Figure 6.1, DFN Package, cleaned up with better quality drawing and dimension table. No specifications were changed in Figure 6.1.
6	August 23, 2012	CDF and CDFR options changed to Preliminary. Added Small Flag DFN illustrations. Reformatted all parametric tables. Revised 8-DFN package drawing to show correct proportion for flag and package. Added MR20H40 as 50MHz speed option. Deleted large flag DFN ordering option for AEC-Q100 products. Corrected errors in DFN package outline drawings.
7	January 17, 2013	Removed Preliminary status from MR25H40CDF, CDFR.
8	May 24, 2013	Removed Preliminary status from MR20H40CDF(R), and from MR20H40DF(R).
9	March 28, 2014	Removed Preliminary status from 25H40MDF(R). $V_{WI} \text{ max}$ to unspecified from TBD. Added MSL-3 status to the Features list.
10	July 11, 2014	MR20H40DF and MR20H40DFR withdrawn from sales status.
11	August 13, 2014	Added Extended temperature grade offering.

## HOW TO REACH US

### Everspin Technologies, Inc.

#### Home Page:

[www.everspin.com](http://www.everspin.com)

#### E-Mail:

[support@everspin.com](mailto:support@everspin.com)

[orders@everspin.com](mailto:orders@everspin.com)

[sales@everspin.com](mailto:sales@everspin.com)

#### USA/Canada/South and Central America

World Headquarters

1347 N. Alma School Road, Suite 220

Chandler, Arizona 85224

1-877-347-MRAM (6726)

1-480-347-1111

#### Europe, Middle East and Africa

[support.europe@everspin.com](mailto:support.europe@everspin.com)

#### Japan

[support.japan@everspin.com](mailto:support.japan@everspin.com)

#### Asia Pacific

[support.asia@everspin.com](mailto:support.asia@everspin.com)

Information in this document is provided solely to enable system and software implementers to use Everspin Technologies products. There are no express or implied licenses granted hereunder to design or fabricate any integrated circuit or circuits based on the information in this document. Everspin Technologies reserves the right to make changes without further notice to any products herein. Everspin makes no warranty, representation or guarantee regarding the suitability of its products for any particular purpose, nor does Everspin Technologies assume any liability arising out of the application or use of any product or circuit, and specifically disclaims any and all liability, including without limitation consequential or incidental damages. "Typical" parameters, which may be provided in Everspin Technologies data sheets and/or specifications can and do vary in different applications and actual performance may vary over time. All operating parameters including "Typicals" must be validated for each customer application by customer's technical experts. Everspin Technologies does not convey any license under its patent rights nor the rights of others. Everspin Technologies products are not designed, intended, or authorized for use as components in systems intended for surgical implant into the body, or other applications intended to support or sustain life, or for any other application in which the failure of the Everspin Technologies product could create a situation where personal injury or death may occur. Should Buyer purchase or use Everspin Technologies products for any such unintended or unauthorized application, Buyer shall indemnify and hold Everspin Technologies and its officers, employees, subsidiaries, affiliates, and distributors harmless against all claims, costs, damages, and expenses, and reasonable attorney fees arising out of, directly or indirectly, any claim of personal injury or death associated with such unintended or unauthorized use, even if such claim alleges that Everspin Technologies was negligent regarding the design or manufacture of the part. Everspin™ and the Everspin logo are trademarks of Everspin Technologies, Inc. All other product or service names are the property of their respective owners.

**Copyright © Everspin Technologies, Inc. 2014**

#### File Name:

EST00459\_MR2xH40\_Datasheet\_Rev11 081314a

# Mouser Electronics

Authorized Distributor

Click to View Pricing, Inventory, Delivery & Lifecycle Information:

[Everspin Technologies:](#)

[MR25H40CDC](#) [MR25H40CDCR](#) [MR25H40CDF](#)