

UG0902
User Guide
PolarFire SoC FPGA Packaging and Pin Descriptions



a  **MICROCHIP** company



a  MICROCHIP company

Microsemi Headquarters

One Enterprise, Aliso Viejo,
CA 92656 USA

Within the USA: +1 (800) 713-4113

Outside the USA: +1 (949) 380-6100

Sales: +1 (949) 380-6136

Fax: +1 (949) 215-4996

Email: sales.support@microsemi.com

www.microsemi.com

©2020 Microsemi, a wholly owned subsidiary of Microchip Technology Inc. All rights reserved. Microsemi and the Microsemi logo are registered trademarks of Microsemi Corporation. All other trademarks and service marks are the property of their respective owners.

Microsemi makes no warranty, representation, or guarantee regarding the information contained herein or the suitability of its products and services for any particular purpose, nor does Microsemi assume any liability whatsoever arising out of the application or use of any product or circuit. The products sold hereunder and any other products sold by Microsemi have been subject to limited testing and should not be used in conjunction with mission-critical equipment or applications. Any performance specifications are believed to be reliable but are not verified, and Buyer must conduct and complete all performance and other testing of the products, alone and together with, or installed in, any end-products. Buyer shall not rely on any data and performance specifications or parameters provided by Microsemi. It is the Buyer's responsibility to independently determine suitability of any products and to test and verify the same. The information provided by Microsemi hereunder is provided "as is, where is" and with all faults, and the entire risk associated with such information is entirely with the Buyer. Microsemi does not grant, explicitly or implicitly, to any party any patent rights, licenses, or any other IP rights, whether with regard to such information itself or anything described by such information. Information provided in this document is proprietary to Microsemi, and Microsemi reserves the right to make any changes to the information in this document or to any products and services at any time without notice.

About Microsemi

Microsemi, a wholly owned subsidiary of Microchip Technology Inc. (Nasdaq: MCHP), offers a comprehensive portfolio of semiconductor and system solutions for aerospace & defense, communications, data center and industrial markets. Products include high-performance and radiation-hardened analog mixed-signal integrated circuits, FPGAs, SoCs and ASICs; power management products; timing and synchronization devices and precise time solutions, setting the world's standard for time; voice processing devices; RF solutions; discrete components; enterprise storage and communication solutions, security technologies and scalable anti-tamper products; Ethernet solutions; Power-over-Ethernet ICs and midspans; as well as custom design capabilities and services. Learn more at www.microsemi.com.

Contents

1	Revision History	1
1.1	Revision 2.0	1
1.2	Revision 1.0	1
2	PolarFire SoC FPGA Packaging and Pin Descriptions	2
2.1	Packaging Overview	2
2.2	Bank Locations	2
2.3	Packaging Pin Assignment	4
2.4	Pin Descriptions	4
2.4.1	User I/O	4
2.4.2	MSS I/Os	6
2.4.3	Supply Pins	7
2.4.4	Memory Interface	9
2.4.5	DDR Interface	9
2.4.6	Clocking Pins	9
2.4.7	Dedicated I/O Bank Pins	9
2.4.8	XCVR Interface	11
2.5	Package Pin-outs	11
2.6	Mechanical Drawings	11
2.7	Package Material Information	13
2.8	Thermal Specifications	14
2.9	Package Marking	14
2.10	Packing and Shipping	14
2.11	Thermal Management	14
2.11.1	System Level Heat Sink Solutions	15
2.12	Thermal Interface Material	15
2.12.1	Heat Sink Attachments	15
2.13	Heat Sink Guidelines for Bare-die Flip-Chip Packages	16
2.14	Heat Sink Removal Procedure	16
2.15	Recommended PCB Design Rules for BGA Packages	17
2.16	Moisture Sensitive Level	18

Figures

Figure 1	PolarFire SoC MPFS250T-FCG1152 I/O Bank Locations	2
Figure 2	PolarFire SoC MPFS250T-FCVG 484 I/O Bank Locations	3
Figure 3	MSS I/O Block Diagram	6
Figure 4	MPFS250T-FCG1152 Package Top-View and Side-View	11
Figure 5	MPFS250T-FCG1152 Package Bottom-View	12
Figure 6	MPFS250T-FCVG484 Package Top-View and Side-View	12
Figure 7	MPFS250T-FCVG484 Package Bottom-View	13
Figure 8	Heat Spreader with Thermal Interface Material	14
Figure 9	Cross Section of Bare-die Flip-chip BGA	16
Figure 10	Recommended Application of Heat Sink	16
Figure 11	Ball and Via Dimensions	17

Tables

Table 1	Organization of I/O Banks	3
Table 2	Serial Transceiver Channels	4
Table 3	Supported I/O Features	5
Table 4	Supply Pins	7
Table 5	Packaging Decoupling Capacitors	8
Table 6	Package De-capacitor Part Number and ESR Values	8
Table 7	JTAG Pins	9
Table 8	Device Reset Pins	9
Table 9	SPI Interface Pins	10
Table 10	Special Pins	10
Table 11	XCVR Interface Pins	11
Table 12	PolarFire SoC FPGAs Package Information	13
Table 13	PolarFire SoC Ball Grid Array RoHS Packages	13
Table 14	PolarFire SoC Ball Grid Array Leaded Packages	14
Table 15	Standard Device Counts per Tray and Carton	14
Table 16	Recommended PCB Design Rules	17
Table 17	Moisture Sensitive Levels	18

1 Revision History

The revision history describes the changes that were implemented in the document. The changes are listed by revision, starting with the current publication.

1.1 Revision 2.0

The following is a summary of the changes made in revision 2.0 of this document.

- Updated "MSS I/Os" section on page 6. Added refer to PolarFire SoC Packaging Pin Assignment Table for the pin out information for the MSS pins.
- Deleted Unused Condition columns from all the details. Added refer to UG0901: PolarFire SoC FPGA Board Design Guidelines User Guide
- Added LPDDR4 memory in "DDR Interface" section on page 9
- Updated "Dedicated I/O Bank Pins" section on page 9. Added UG0901: PolarFire SoC FPGA Board Design Guidelines User Guide
- Updated "XCVR Interface" section on page 11. Added UG0901: PolarFire SoC FPGA Board Design Guidelines User Guide

1.2 Revision 1.0

Revision 1.0 was the first publication of this document.

2 PolarFire SoC FPGA Packaging and Pin Descriptions

This guide provides pin and packaging information (such as bank assignments and mechanical information) for PolarFire® SoC FPGAs.

PolarFire SoC FPGAs feature a flexible I/O structure that supports a range of mixed voltages (1.1 V, 1.2 V, 1.35 V, 1.5 V, 1.8 V, 2.5 V, and 3.3 V) through bank selection. The HSIO and GPIO are configured as differential I/Os or two single-ended I/Os. For more information about HSIO, GPIO, and supported I/O standards, see *UG0916: PolarFire SoC FPGA IO User Guide*.

2.1 Packaging Overview

PolarFire SoC FPGAs are available in multiple packages. Each package (device variant) has various I/O banks to allow the flexibility of using different I/O standards. HSIO and GPIO banks have a maximum supply voltage of 1.8 V and 3.3 V, respectively.

The following table lists the PolarFire SoC FPGA variants, with user I/O and XCVR lanes, in Pb-free packages.

Table to be added.

2.2 Bank Locations

PolarFire SoC FPGA I/O are grouped based on I/O voltage standards and I/O capabilities. Each I/O bank has dedicated I/O supplies and ground voltages. Because of these dedicated supplies, only I/O with compatible standards are assigned to the same I/O voltage bank.

The following illustrations show the bank locations for the MPFS250T device with available package combinations.

Figure 1 • PolarFire SoC MPFS250T-FCG1152 I/O Bank Locations

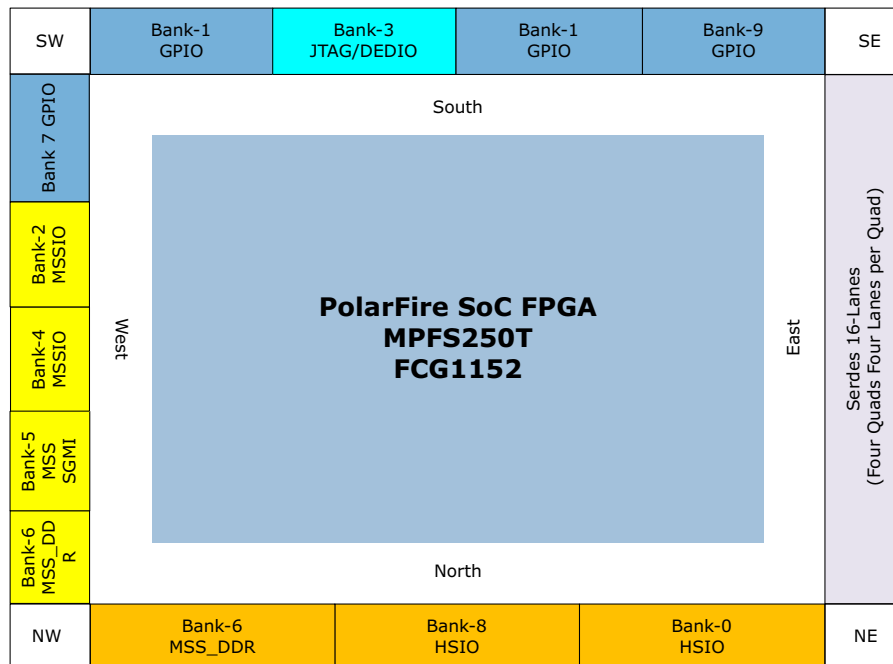
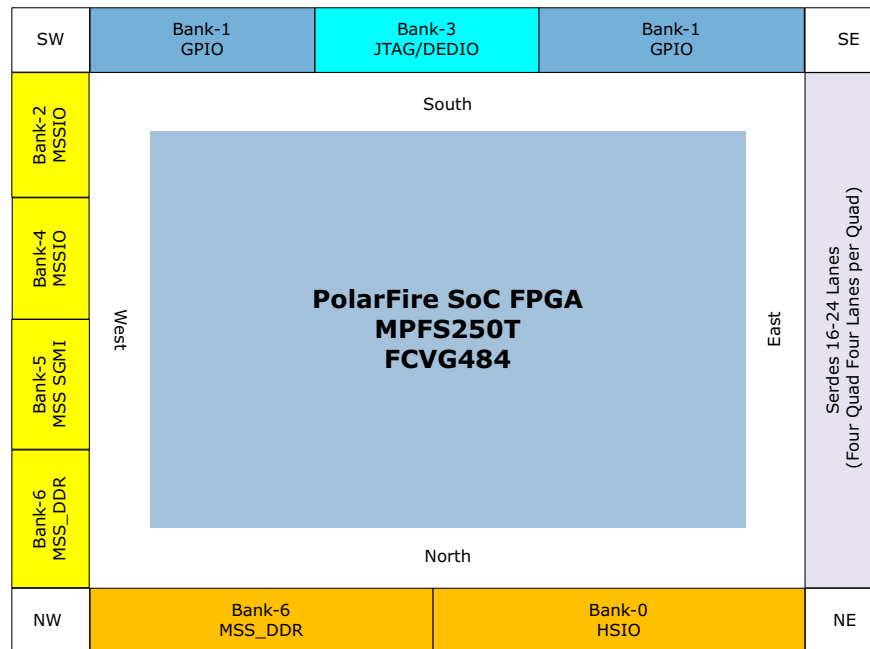

Figure 2 • PolarFire SoC MPFS250T-FCVG 484 I/O Bank Locations

The following table lists the organization of the I/O banks in PolarFire SoC MPFS250T device in FCG1152 and FCVG484 packages. Each XCVR supports four lanes in every package. In all the packages, PCIe is supported only in XCVR0.

Table 1 • Organization of I/O Banks

Bank Number	FCG1152	FCVG484
	MPFS250T	MPFS250T
Bank 0	HSIO	HSIO
Bank 1	GPIO	GPIO
Bank 2	MSSIO	MSSIO
Bank 3	JTAG/ FIXED I/O	JTAG/ FIXED I/O
Bank 4	MSSIO	MSSIO
Bank 5	MSS-SGMII	MSS-SGMII
Bank 6	MSS-DDR	MSS-DDR
Bank 7	HSIO	
Bank 8	HSIO	
Bank 9	GPIO	
XCVR 0	Yes	Yes
XCVR 1	Yes	
XCVR 2	Yes	
XCVR 3	Yes	

Each I/O bank supports multiple DDR lanes. If CDR/SGMII interface is connected to the I/O bank, the Tx and Rx signal must be within the same DDR Lane. Only one CDR/SGMII is allowed per DDR lane. For more information about DDR lanes for each package in *PolarFire SoC Packaging Pin Assignment Table* (PPAT).

The following table lists the XCVR channels for PolarFire SoC device/package.

Table 2 • Serial Transceiver Channels

Device	FCG1152	FCVG484
MPFS250T	16	4

2.3 Packaging Pin Assignment

PolarFire SoC Packaging Pin Assignment Table (PPAT) contains information about recommended DDR pin-outs, PCI Express capability for XCVR-0, DDR Lane information for IO CDR, and generic IOD interface pin placement.

2.4 Pin Descriptions

PolarFire SoC devices have user I/O (GPIO/HSIO) pins, dedicated I/O bank pins, memory interface, XCVR interface, clocking pins, and supply pins.

2.4.1 User I/O

PolarFire SoC FPGA I/Os are paired up to meet the differential I/O standards and grouped into lanes of 12 buffers with a lane controller for memory interfaces. For more information about the memory controller, see *UG0906: PolarFire SoC FPGA DDR Memory Controller User Guide*.

There are two types of I/O buffers—HSIO and GPIO. HSIO is optimized for 1.2 Gbps (DDR4) operation with operating supplies between 1.1 V and 1.8 V. GPIO buffers support a wider range of I/O interfaces with speeds of up to 1066 Mbps when using single-ended standards and 1.25 Gbps when using differential standards, and operating supplies ranging from 1.2 V to 3.3 V. GPIO supports multiple standards, including 3.3 V with an integrated Clock Data Recovery (CDR) to high-speed serial interfaces such as 1GbE.

Each PolarFire SoC FPGA user I/O uses a IOxyBz naming convention, where:

- **IO** = the type of I/O.
- **x** = the I/O pair number in bank z.
- **y** = P (positive) or N (negative). In single-ended mode, the I/O pair operates as two separate I/O—P and N. Differential mode is implemented with a fixed I/O pair and cannot be split with an adjacent I/O.
- **B** = bank (see note in *Supported I/O Features*, page 5).
- **z** = bank number.

GPIOxyBz and HSIOxyBz are bi-directional user I/O pins that are capable of differential signaling.

2.4.1.1 Supported I/O Features

The following table lists the I/O features supported on HSIO and GPIO.

Table 3 • Supported I/O Features

I/O Feature	HSIO	GPIO	Additional Information
Programmable on/off clamp		Yes	
Hot-plug		Yes	
Cold sparing	Yes	Yes	
True differential output driver		Yes	
Programmable on/off 100 Ω differential termination		Yes	
PVT-compensated output drive	Yes	Yes	
Programmable slew control		Yes	
PVT compensated slew control	Yes		
Programmable input hysteresis	Yes	Yes	
Mobile Industry Processor Interface (MIPI) (input)		Yes	High-speed and low-power.
MIPI (output)		Yes	High-speed.

Note: Bank 5 VDDI power pins are connected to Bank 4 VDDI power pins within package substrates for pin migration compatibility.

2.4.2 MSS I/Os

The PolarFire SoC family offers the industry's first RISC-V based SoC FPGAs. The PolarFire SoC family combines a powerful 64-bit 5x core RISC-V Microprocessor Sub-System (MSS) with the FPGA fabric in a single device. Packed with this powerful combination, PolarFire SoC devices offer the scalable features of FPGAs and high-performance of ASICs. Only the FPGA fabric resources vary and the MSS remains the same across PolarFire SoC device variants, making these devices ideal for many applications.

Figure 3 • MSS I/O Block Diagram

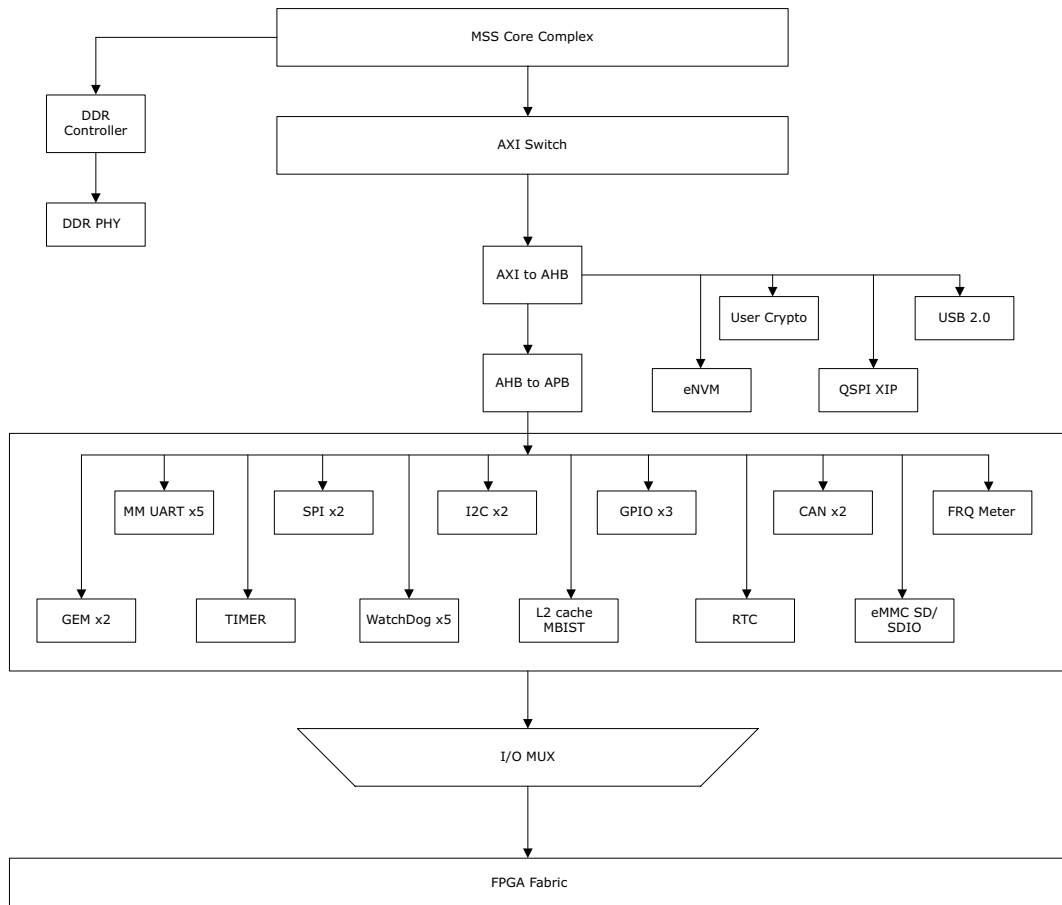

There are 38 MSS I/Os which can be configured using the Libero SoC software to interface with various peripherals. See [PolarFire SoC Packaging Pin Assignment Table](#) for the pin out information for the MSS pins. The pin out provided multiple options on where the MSS peripherals may be connected. All the interfaces are configured using the software.

- CAN Controller (x2)
- I2C (x2)
- MMUART (x5)
- SPI (x2)
- Quad SPI with XIP
- Gigabit Ethernet MAC (GEM x2)
- eMMC SD/SDIO
- Universal Serial Bus OTG Controller (USB)
- DDR Controller
- GPIO

2.4.3 Supply Pins

The following table lists multiple power supply pins required for proper device operation. For information about unused conditions and power sequence, see *UG0901: PolarFire SoC FPGA Board Design Guidelines User Guide*.

Table 4 • Supply Pins

Name	Description	Operating Voltage
XCVR_VREF ¹	Voltage reference for transceiver.	0.9 V/1.25 V
VDD_XCVR_CLK	Power for transceiver reference clock input buffers.	2.5 V/3.3 V
VDDA25	Transceiver PLL power	2.5 V
VDDA	Power for transceiver Tx and Rx lanes 0, 1, 2, 3.	1.0 V/1.05 V
VSS	Core digital ground.	NA
VDD	Device core digital supply.	1.0 V/1.05 V
VDDIx (JTAG Bank)	Supply for I/O circuits in a bank.	1.8 V/2.5 V/3.3 V
VDDIx (GPIO Banks)	Supply for I/O circuits in a bank.	1.2 V/1.5 V/1.8 V/2.5 V/3.3 V
VDDIx (MSSIO Banks)	Supply for MSS I/O circuits in a bank.	1.2 V/1.5 V/1.8 V/2.5V/3.3V
VDDIx (MSS SGMII Banks)	Supply for MSS SGMII circuits in a bank.	2.5V/3.3V
VDDIx (MSS DDR Bank)	Supply for MSS DDR circuits in a bank.	1.2V/1.5 V/1.8 V

1. SSTL25 (stub series terminated logic) I/O standard for 1.25 V VREF, SSTL18 I/O standard for 0.9 V, and HSUL18 I/O standard for 0.9 V.

2.4.3.1 Packaging Decoupling Capacitors

PolarFire SoC 0.8 mm and 1.0 mm pitch packages contain decoupling capacitors to support high-speed I/O operation.

Small, low-profile CSP packages (0.5 mm ball pitch, 16 mm × 16 mm and smaller) do not have package decoupling capacitors.

The following table lists the packaging decoupling capacitors contained in non-CSP packages.

Table 5 • Packaging Decoupling Capacitors

Power Supply	0.8 mm Pitch		1 mm Pitch	
	Number of Capacitors	Value	Capacitors Available	Value
VDDI0			1	1 μ F/4 V
VDDI1			1	1 μ F/4 V
VDDI2			TBD	
VDDI4			TBD	
VDDI5			TBD	
VDDI6			1	1 μ F/4 V
VDDI7 ¹			1	1 μ F/4 V
VDDI8 ¹			1	1 μ F/4 V
VDDI9 ¹			1	1 μ F/4 V
VDD18			1	1 μ F/4 V
VDDA	2	4.7nF /6.3 V 1.0nF/16.0 V	4	4.7nF/6.3 V 2.2 nF/6.3 V 1.5 nF/6.3 V 1.0 nF/16.0 V
VDD25			1	1 μ F/4 V

- 0.8 mm pitch PolarFire SoC packages do not support VDDI7, VDDI8, and VDDI9.

Table 6 • Package De-capacitor Part Number and ESR Values

Capacitance Value	Part numbers	Package	ESR (Ω)
4.7 nF	GRM033R70J472KA01	0201	0.09724812
2.2 nF	GRM033R70J222KA01	0201	0.16111
1.5 nF	GRM033R70J152KA01	0201	0.194915396
1 nF	CGA1A2X7R1C102K030BA	0201	0.2444
1 μ F	LLR185C70G105ME01L	0306	0.005475757
1 μ F	LLL185C70J105ME14K	0306	0.005009904
2.2 μ F	W2L14C225MAT1A	0508	0.003964

2.4.4 Memory Interface

Valid locations for DDR memory interfaces are shown in *PolarFire SoC Packaging Pin Assignment Table*. By using Libero SoC, all individual DDR interface pins are identified from the DDR macro. For more information on the memory interface, see *UG0906: PolarFire SoC FPGA DDR Memory Controller User Guide*.

2.4.5 DDR Interface

The DDR subsystems are hardened ASIC blocks for interfacing the LPDDR3, LPDDR4, DDR3, and DDR4 memories. It supports 16-, 32-, and 64-bit data bus width modes with ECC support. The DDRIO uses fixed impedance calibration for different drive strengths. These values are programmed using Libero SoC software for the selected I/O standard. The values are fed to the pull-up or pull-down reference network to match the impedance with an external resistor. For more information on DDR signals, see *UG0906: PolarFire SoC FPGA DDR Memory Controller User Guide*.

2.4.6 Clocking Pins

CCC blocks, located at each corner of the PolarFire SoC FPGAs, contain two PLLs and two DLLs that provide flexible on-chip and off-chip clock management and synthesis capabilities. CCCs are labeled according to their locations in the core. For example, the CCC located in the northeast corner is labeled as CCC_NE. For more information on clocking pins, see *UG0913: PolarFire SoC FPGA Clocking Resources User Guide*.

Preferred clock inputs (CLKIN) are located on three sides of the device, with eight preferred clock inputs on the west side, twelve on the north side, and either 12 or 16 inputs on the south side, depending on the package. The following table lists the clocking pin names and descriptions. See *Table 4*, page 7 for more information on CCC pin voltage.

2.4.7 Dedicated I/O Bank Pins

JTAG, SPI, and DEVRST_N signals share the same bank 3 supply and are not directly available to the fabric. SPI I/O are, however, dynamically switched over to be used by the fabric whenever the PolarFire SoC controller is not using them. Dedicated I/O bank supplies must be powered up higher than their operational threshold and enabled before the PolarFire SoC controller negates the main power-on reset to the FPGA fabric. The following tables list the JTAG, SPI, and DEVRST_N pin names and descriptions. Libero configures unused user I/O as input buffer disabled, output buffer tri-stated with weak pull-up.

For information about unused conditions and power sequence, see *UG0901: PolarFire SoC FPGA Board Design Guidelines User Guide*.

Table 7 • JTAG Pins

Name	Direction	Weak Pull-up	Description
TMS	Input	15 K Ω to VJTAG	JTAG Test Mode Select (TMS).
TDI	Input	15 K Ω to VJTAG	JTAG data input pin. In ATPG/test mode, when using a 4-bit TDI bus, this I/O is used as TDI[0].
TDO	Output		JTAG data out.
TCK	Input		JTAG clock.
TRSTB	Input	15 K Ω to VJTAG	JTAG reset (asserted low).

Table 8 • Device Reset Pins

Name	Direction	Weak Pull-up	Description
DEVRST_N	Input	22 K Ω	Device reset (asserted low).

Table 9 • SPI Interface Pins

Name	Direction	Description
SCK	Bi-directional	SPI clock.
SS	Bi-directional	SPI slave select.
SDI	Input	SDI input for the shared SPI interface.
SDO	Output	SDO output for the shared SPI interface.
SPI_EN	Input	Pulled up or down through a resistor or driven dynamically from an external source to enable or tri-state the SPI I/O.
IO_CFG_INTF	Input	Pulled up or down through a resistor or driven dynamically from an external source to indicate whether the shared SPI interface is a master or a slave. Dedicated to the system controller. 0: SPI slave interface 1: SPI master interface

Table 10 • Special Pins

Name	Direction	Description
NC	–	No connect pin. This pin indicates that it is not connected within the circuitry. NC pins can be driven by any voltage or can be left floating with no effect on the operation of the device.
DNC	–	Do not connect pin. DNC pins must not be connected to any signals on the PCB, and they must be left unconnected.
LPRB_A	Output	Specifies an internal signal for probing (oscilloscope-like feature). The two live probe I/O cells function as either of the following: – Live probe – User I/O (HSIO)
LPRB_B	Output	
FF_EXIT_N	Input	RESERVED
Shield Signal	Output	Shield signal is required for each DDR data byte signal. It must be driven with maximum drive strength to improve the signal integrity.

2.4.8 XCVR Interface

The transceiver I/O available in the PolarFire SoC devices are dedicated for high-speed serial communication protocols. Libero Defined DNC pins are pulled up internally when not used in the Libero design.

For information about unused conditions and power sequence, see *UG0901: PolarFire SoC FPGA Board Design Guidelines User Guide*.

Table 11 • XCVR Interface Pins

Name	Direction	Description
XCVR_xy_REFCLK_P	Input	Differential serial reference clock xy - location
XCVR_xy_REFCLK_N		
XCVR_x_Txy_P	Output	Differential serial transmit pins. x - transceiver number (0, 1, 2, 3) y - lane number (0, 1, 2, 3)
XCVR_x_Txy_N		
XCVR_x_Rxy_P	Input	Differential serial receive pins. x - transceiver number (0, 1, 2, 3) y - lane number (0, 1, 2, 3)
XCVR_x_Rxy_N		

2.5 Package Pin-outs

For more information about the pin-outs, see *PolarFire SoC Packaging Pin Assignment Table*.

2.6 Mechanical Drawings

The following illustrations show the top, bottom, and side views and dimensions for the PolarFire SoC FPGAs.

Figure 4 • MPFS250T-FCG1152 Package Top-View and Side-View

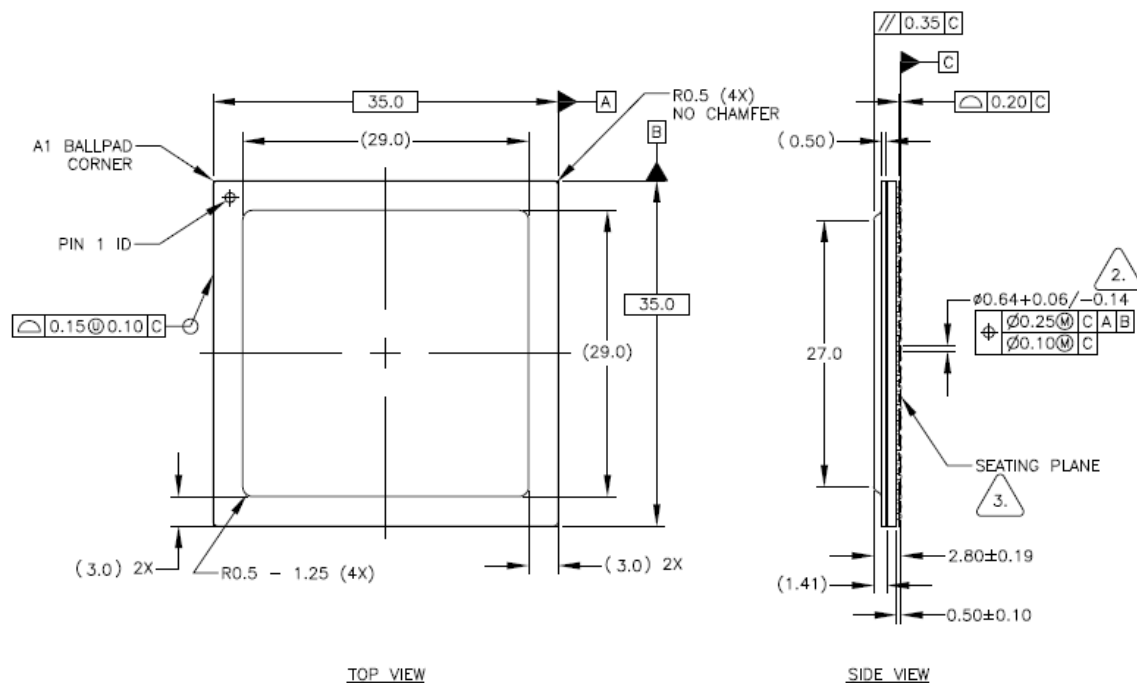

Figure 5 • MPFS250T-FCG1152 Package Bottom-View

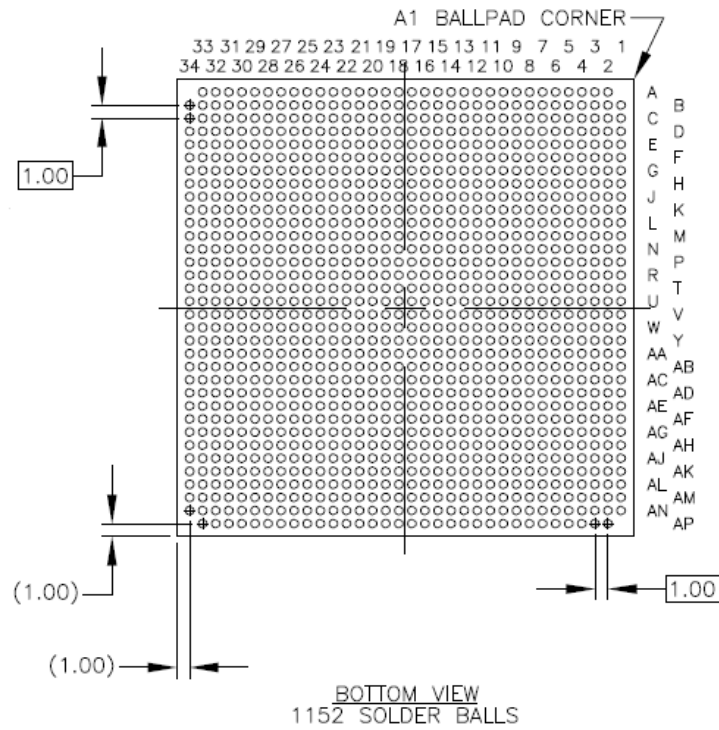

Figure 6 • MPFS250T-FCVG484 Package Top-View and Side-View

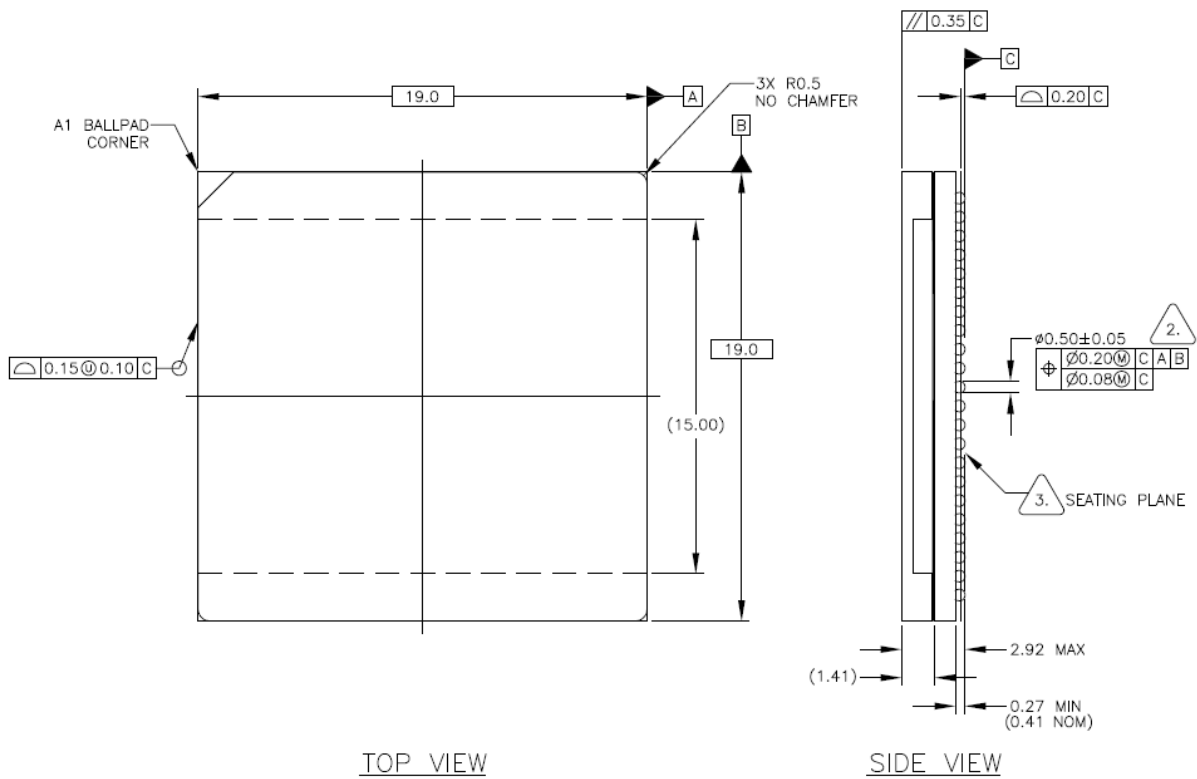
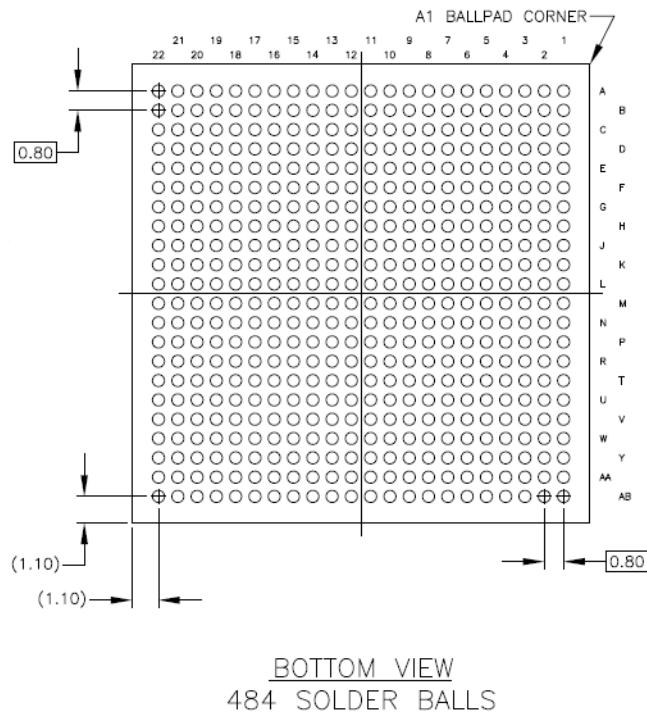

Figure 7 • MPFS250T-FCVG484 Package Bottom-View



The following table lists the PolarFire SoC FPGAs Package description and specification.

Table 12 • PolarFire SoC FPGAs Package Information

Package	Description	Package Specifications			
		Package type	Pitch (mm)	Size (mm)	Maximum I/Os
FCG1152	Flip-chip with lid	BGA	1	35 × 35	512
FCVG484	Flip-chip with lid	BGA	0.8	19 × 19	284

2.7 Package Material Information

The following table lists the PolarFire SoC ball grid array RoHS packages.

Table 13 • PolarFire SoC Ball Grid Array RoHS Packages

Package Balls	FCG1152	FCVG484
Package Pitch	1 mm	0.8 mm
Substrate Material	Epoxy Glass	Epoxy Glass
Solder Ball Composition RoHS	SAC305	SAC305
Solder Bump Material	Sn98.2/Ag1.8	Sn98.2/Ag1.8

All flip-chip BGA packages—FCG1152 and FCVG484—are vented.

Table 14 • PolarFire SoC Ball Grid Array Leaded Packages

Flip-chip Packages	Ball Pad Diameter (mm)	Ball Pad Opening (mm)	Vent Dimension (mm)	Vented Package
MPFS250T - FCG1152 (with heat spreader)	TBD	TBD	TBD	TBD
MPFS250T - FCVG484 (Bare Die)	TBD	TBD	TBD	TBD

2.8 Thermal Specifications

To be updated.

2.9 Package Marking

To be updated.

2.10 Packing and Shipping

The PolarFire SoC series devices are packed in trays, which are used to pack most of the Microsemi surface-mount devices. Trays provide excellent protection from mechanical damage. In addition, they are manufactured using the anti-static material to provide limited protection against ESD damage.

Table 15 • Standard Device Counts per Tray and Carton

Package	Maximum Number of Devices Per Tray	Maximum Number of Trays Per Stack	Maximum Number of Units per Inner Carton
FCG1152	TBD	TBD	TBD
FCVG484	TBD	TBD	TBD

2.11 Thermal Management

Microsemi PolarFire SoC FPGAs are offered in lidded flip-chip BGA (FCBGA) format. Lidded FCBGA features a controlled bond-line thermal interface material (TIM) thickness that reduces the thermal resistance (Theta-JC) between the junction and the externally applied thermal solution. The lid or heat spreader also spreads the heat away from the die to the package perimeter and to the printed circuit board.

Optimized package electrical performance with multiple power and ground planes to take care of signal return paths, and dense core via under the die to improve power delivery adds benefit in dissipating heat through the bottom of the package and to the board.

PolarFire SoC FPGAs in FCVG484 are also available in bare die FCBGA. Bare die flip-chip BGA produces the lowest possible thermal resistance (Theta-JC) between the junction and any externally applied thermal solution.

Figure 8 • Heat Spreader with Thermal Interface Material

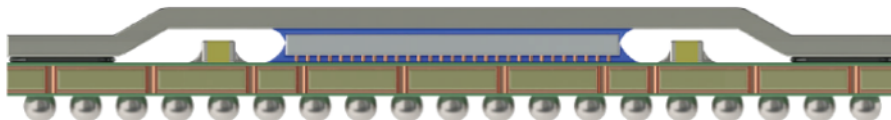

2.11.1 System Level Heat Sink Solutions

The use of external heat sinks, component placement in the PCB, and air flow in the system depends on the physical and mechanical limitations of the system. A system level thermal design engineer must understand these limitations and device capabilities to effectively manage the complete thermal strategy.

2.12 Thermal Interface Material

When using external heat sinks, a suitable thermal interface material must be considered to effectively transfer the heat from the component to the heat sink, and eventually to the environment.

For bare-die flip-chip BGAs, the surface of the silicon contacts the heat sink. For lidded flip-chip BGAs, the lid contacts the heat sink. The surface size of the bare-die flip-chip BGA and lidded flip-chip BGAs are different. Microsemi recommends a different type of thermal material for long-term use with each type of flip-chip BGAs package.

For lidded flip-chip BGAs, the lid contacts the external heat sink while bare die flip-chip BGAs, the surface of the silicon contacts the external heat sink. The surface areas of lidded flip-chip BGAs and bare die flip-chip BGAs are different. The system level thermal design engineer must choose the appropriate TIM to be used.

Thermal interface material is required because the surfaces of both the PolarFire SoC package and heat sinks base are not smooth. The surface roughness reduces the effective contact area between the package and the heat sinks base. The insulating air gaps created by voids between contacting surfaces are too large. The thermal interface materials fill these gaps and allow an effective conductive transfer of heat from the package to the external heat sink.

The selection of the appropriate thermal interface material is critical to ensure the lowest thermal contact resistance. One must consider the thermal conductivity of the TIM—the flatness of the surface contact areas, the applied pressure on the thermal interface material and the total thermal contact area. In addition to thermal performance, TIMs are selected based on the ease of use in assembly and long term reliability.

2.12.1 Heat Sink Attachments

There are six main methods for heat sink attachment. The following table lists their advantages and disadvantages.

- Thermal tape
- Thermally conductive adhesive
- Wire form Z-clips
- Plastic clip-ons
- Threaded stand-offs (PEMs) and compression springs
- Push-pins and compression springs
- Thermal compound (also called as thermal gel, thermal grease, thermal paste, heat-sink paste or heat-sink compound)

2.13 Heat Sink Guidelines for Bare-die Flip-Chip Packages

Heat sinks can be attached to the package in multiple ways. For heat to dissipate effectively, the advantages and disadvantages of each heat sink attachment method must be considered. Factors influencing the selection of the heat sink attachment method include the package type, contact area of the heat source, and the heat sink type.

When designing heat sink attachments for bare-die flip-chip BGA packages, the height of the die higher than the substrate and also the height of decoupling capacitors must be considered. This is to prevent electrical shorting between the heat sink (metal) and the decoupling capacitors. When attaching the heat sink to the bare-die flip-chip BGA, ensure that the TIM thickness and the force applied during heat sink placement are even.

Figure 9 • Cross Section of Bare-die Flip-chip BGA

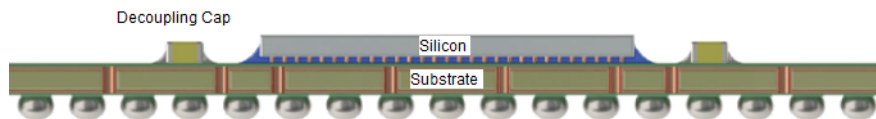

Care must be taken while attaching a heat sink to the bare-die package after the component is placed onto the PCBs.

Figure 10 • Recommended Application of Heat Sink

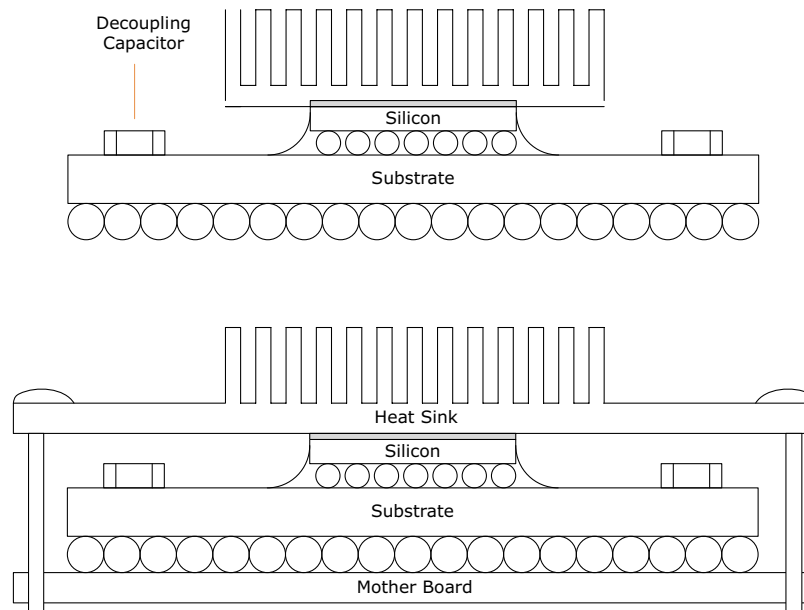

2.14 Heat Sink Removal Procedure

The heat spreader on the package provides mechanical protection for the die and serves as the primary heat dissipation path. It is attached with an epoxy adhesive to provide the necessary adhesion strength to hold the package together. For an application in which an external heat sink subjects the lid adhesion joint to continuous tension or shear, extra support might be required.

Also, if the removal of an attached external heat sink subjects the joint to tension, torque, or shear, care should be exercised to ensure that the lid itself does not come off. In such cases, it has been found useful to use a small metal blade or metal wire to break the lid to heat sink joint from the corners and carefully pry the heat sink off. The initial cut should reach far in enough so that the blade has leverage to exert upward pressure against the heat sink. Contact the heat sink and heat sink adhesive manufacturer for more specific recommendations on heat sink removal.

2.15 Recommended PCB Design Rules for BGA Packages

Microsemi provides the diameter of a land pad on the package side. This information is required before the start of the board layout so the board pads can be designed to match the component-side land geometry. The typical values of these land pads are shown in the following figure and summarized in Table 16, page 17. For Microsemi BGA packages, Non-Solder Mask Defined (NSMD) pads on the board are suggested to allow a clearance between the land metal (diameter) and the solder mask opening (diameter) as shown in the following figure.

The space between the NSMD pad and the solder mask; the actual signal trace widths and via dimensions depend on the capability of the PCB vendor. The cost of the PCB is higher when the line width and spaces are smaller.

Figure 11 • Ball and Via Dimensions

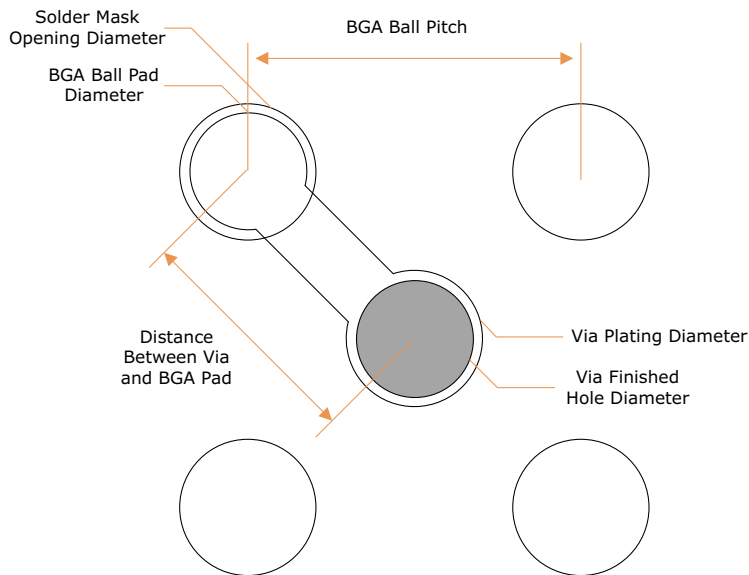

Table 16 • Recommended PCB Design Rules

Design Rule for Packages	0.8 mm Pitch	1.0 mm Pitch
	FCVG	FCG
BGA Ball Pad diameter	0.4 mm	0.51 mm
Solder mask opening diameter	0.43 mm	0.54 mm
BGA Ball pitch	0.8 mm (31.5 mils)	1.00 mm (39.37 mils)
Line width between via and solder land	0.13 mm	0.15 mm
Distance between via and solder land	0.56 mm	0.7 mm
Via Finished hole diameter	0.33 mm	0.33 mm
Via Plating diameter	0.48 mm	0.48 mm

Note: For more information about package fanout, see [PolarFire SoC FPGA Package Fanout Application Note](#) (yet to be published).

2.16 Moisture Sensitive Level

The following table lists Microsemi PolarFire SoC packages Moisture Sensitive Levels (MSL). For information about solder re-flow guidelines for Sn/Pb and Pb-free, see <https://www.microsemi.com/company/quality/soldering-profiles>

Table 17 • Moisture Sensitive Levels

Package	MSL
FCG1152	4
FCVG484	4