

DO NOT SCALE FROM THIS PRINT

DESIGNED & DIMENSIONED IN MILLIMETERS [INCHES]

SEE NOTE 12

FIG 1

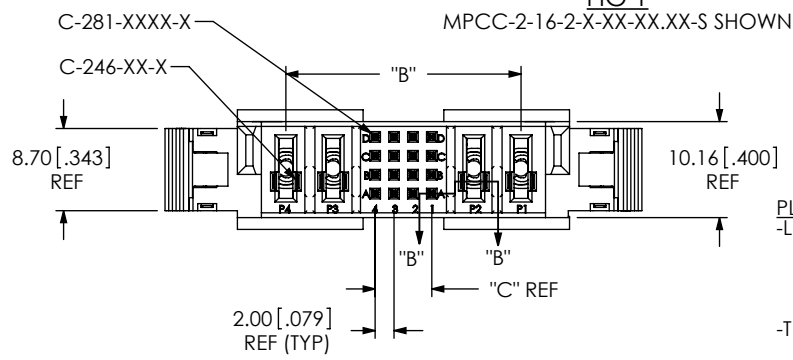

MPCC-X-XX-X-X-XX-XX.XX-X-XXX

POWER PINS (PER END) -2

SIGNAL PINS (SEE TABLE 2, SHT 2 FOR AVAILABLE COMBINATIONS)
-16 (4x4)
-24 (4x6)

POWER PINS (PER END) -2

PLATING

-L: **POWER PINS:** 10µ" SELECTIVE GOLD IN CONTACT AREA, MATTE TIN ON TAIL
SIGNAL PINS: 10µ" SELECTIVE GOLD IN CONTACT AREA, BRIGHT ACID TIN ON TAIL
-T: **POWER PINS:** MATTE TIN OVER ENTIRE PIN
SIGNAL PINS: 10µ" SELECTIVE GOLD IN CONTACT AREA, BRIGHT ACID TIN

XXX OPTION (END 2)
(ONLY AVAILABLE WITH -D, LEAVE BLANK FOR -S OPTION)
(APPLIES TO SIGNALS ONLY, POWER STRAIGHT THRU)
-NUS: NOTCH UP, STRAIGHT (PIN A1 TO PIN AX)
*NDS: NOTCH DOWN, STRAIGHT (PIN A1 TO PIN A4)
*NUS: NOTCH UP, CROSSED (PIN A1 TO PIN DX)
*NDX: NOTCH DOWN, CROSSED (PIN A1 TO PIN A1)

ASSEMBLED LENGTH (INCHES)
04.00 INCH MINIMUM

END OPTION
-S: SINGLE ENDED
-D: DOUBLE ENDED (MUST CHOOSE FROM -NXX OPTIONS)

LEAD STYLE

- 44 (14 AWG PWR, 24 AWG SIG)
- 46 (14 AWG PWR, 26 AWG SIG)
- 48 (14 AWG PWR, 28 AWG SIG)
- 40 (14 AWG PWR, 30 AWG SIG)
- 64 (16 AWG PWR, 24 AWG SIG)
- 66 (16 AWG PWR, 26 AWG SIG)
- 68 (16 AWG PWR, 28 AWG SIG)
- 60 (16 AWG PWR, 30 AWG SIG)

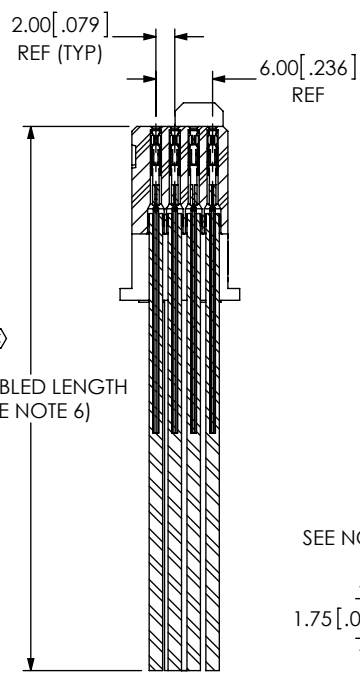
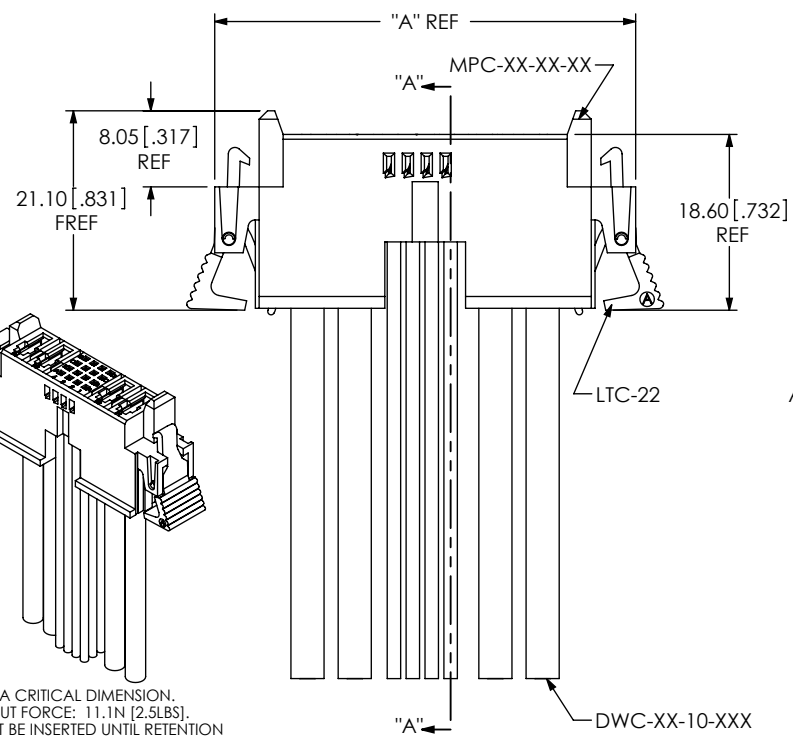

SECTION "A"-"A" SCALE 1.25 : 1

* = NOT RELEASED

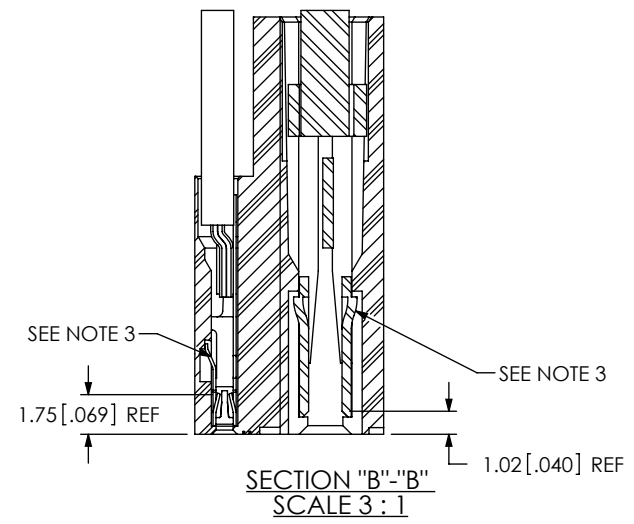

SECTION "B"-"B" SCALE 3 : 1

NOTES:

1. Ⓢ REPRESENTS A CRITICAL DIMENSION.
2. MINIMUM PULLOUT FORCE: 11.1N [2.5LBS].
3. CONTACTS MUST BE INSERTED UNTIL RETENTION FEATURES LOCK INTO PLACE.
4. ALL FINISHED GOODS ARE TO BE ELECTRICALLY TESTED INCLUDING HI-POT TEST AT 1000 VOLTS DC. AFTER FINAL ELECTRICAL TEST, LABEL EACH ASSEMBLY WITH (1) ET STAMP ON THE BODY.
5. TINNED COPPER WIRE IS ROHS COMPLIANT.
6. FOR LENGTHS OF 12.00 INCHES AND LESS, TOLERANCE TO BE ± 3.18 [125], FOR LENGTHS GREATER THAN 12.00 INCHES, TOLERANCE TO BE ± 2%.
7. REFER TO CRIMP SPECIFICATIONS PRINT FOR CRIMP AND STRIP DIMENSIONS, TOLERANCES, TOOLING, AND ITS REQUIREMENTS.
8. MINIMUM WIRE CRIMP STRENGTH: 24-28 AWG: 20.0N[4.5LB]
30 AWG: 13.3N[3.0 LB]
9. MINIMUM LATCH RETENTION: 4.4 N [1 LB].
10. MINIMUM DWC RETENTION: 22.2 N [5.0 LB]
11. PARTS TO BE LAYER PACKAGED. COVER EACH CABLE END WITH BAG ASBBLT X.X X X.X.
FOR VERY SHORT CABLES THAT WILL FIT 100% WITHIN ONE BAG, USE ONLY ONE BAG AND SEAL.
12. ALL DIMS SHOWN IN METRIC EXCEPT FOR ASSEMBLY LENGTH ON PART CALL OUT.
13. NOT FOR SALE AS COMPONENTS; SOLD AS A CABLE ASSEMBLY ONLY.
14. CUT LENGTH IS ASSEMBLY LENGTH MINUS OVERALL LENGTH SUBTRACTOR.

UNLESS OTHERWISE SPECIFIED, DIMENSIONS ARE IN MILLIMETERS. TOLERANCES ARE:
DECIMALS ANGLES
X.X: ±0.3 [01] 2°
X.XX: ±0.13 [005]
X.XXX: ±0.051 [0020]

PROPRIETARY NOTE
THIS DOCUMENT CONTAINS CONFIDENTIAL AND PROPRIETARY INFORMATION AND ALL DESIGN, MANUFACTURING, REPRODUCTION, USE, PATENT RIGHTS AND SALES RIGHTS ARE EXPRESSLY RESERVED BY SAMTEC, INC. THIS DOCUMENT SHALL NOT BE DISCLOSED, IN WHOLE OR PART, TO ANY UNAUTHORIZED PERSON OR ENTITY NOR REPRODUCED, TRANSFERRED OR INCORPORATED IN ANY OTHER PROJECT IN ANY MANNER WITHOUT THE EXPRESS WRITTEN CONSENT OF SAMTEC, INC.

	
520 PARK EAST BLVD. NEW ALBANY, IN 47150 PHONE: 812-944-6733 FAX: 812-948-5047 e-Mail: info@SAMTEC.com code 55322	
DESCRIPTION: MINI POWER COMBO CABLE ASSEMBLY	
DWG. NO. MPCC-X-XX-X-X-XX-XX.XX-X-XXX	
BY: D.SCHMELZ 05/26/2010	SHEET 1 OF 3

DO NOT SCALE DRAWING

SHEET SCALE: 1.5:1

TABLE 2							
PART NUMBER	BODY	"A"		"B"		"C"	
MPCC-2-16-2-XX-XX.XX-X-XXX	MPC-2-16-2	44.55	[1.754]	24.89	[0.980]	6.00	[0.236]
MPCC-2-24-2-XX-XX.XX-X-XXX	MPC-2-24-2	48.55	[1.911]	28.89	[1.137]	10.00	[0.394]

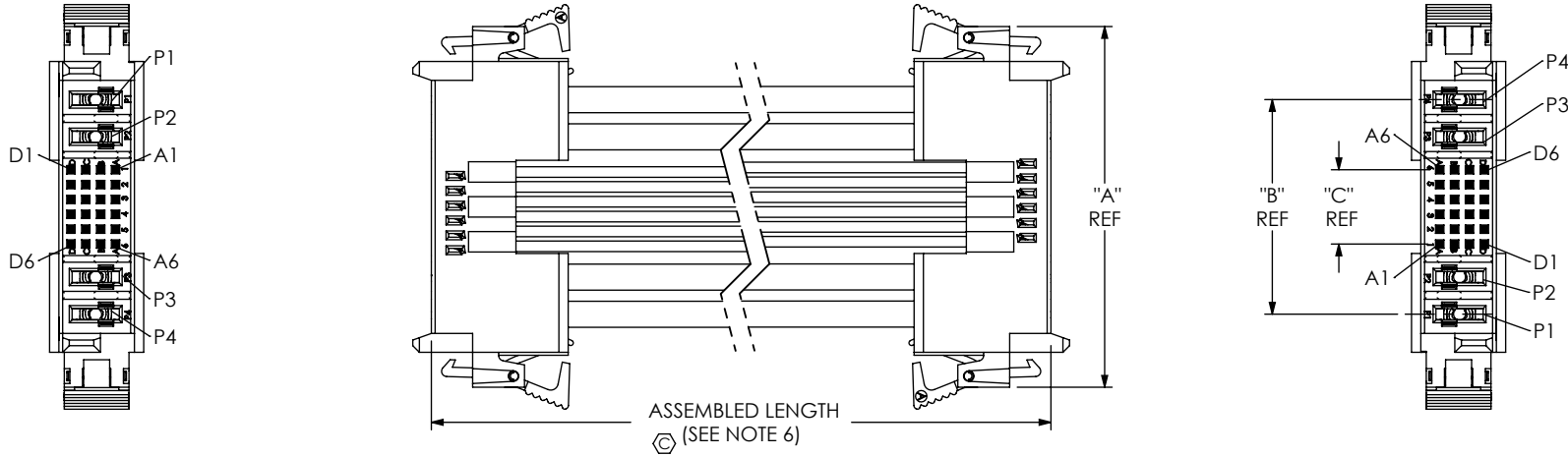

FIG 3
MPCC-2-24-2-X-XX-XX.XX-D-NUS SHOWN
(DIFFERENT AS SHOWN, OTHERWISE SAME AS FIG 1 & 2)

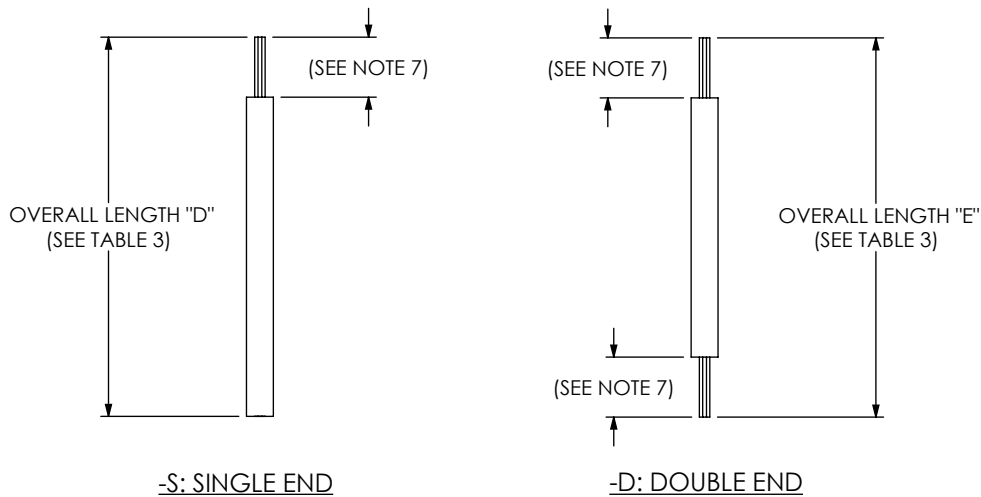

FIG 2
CABLE CUT IN-PROCESS

TABLE 3: OVERALL LENGTH SUBTRACTORS (SEE NOTE 14)			
SERIES		"D"	"E"
MPCC	SIGNAL WIRE	0.113	0.226
	POWER WIRE	0.312	0.624

PROPRIETARY NOTE
THIS DOCUMENT CONTAINS CONFIDENTIAL AND PROPRIETARY INFORMATION AND ALL DESIGN, MANUFACTURING, REPRODUCTION, USE, PATENT RIGHTS AND SALES RIGHTS ARE EXPRESSLY RESERVED BY SAMTEC, INC. THIS DOCUMENT SHALL NOT BE DISCLOSED, IN WHOLE OR PART, TO ANY UNAUTHORIZED PERSON OR ENTITY NOR REPRODUCED, TRANSFERRED OR INCORPORATED IN ANY OTHER PROJECT IN ANY MANNER WITHOUT THE EXPRESS WRITTEN CONSENT OF SAMTEC, INC.

DO NOT SCALE DRAWING

SHEET SCALE: 1:1



520 PARK EAST BLVD, NEW ALBANY, IN 47150
PHONE: 812-944-6733 FAX: 812-948-5047
e-Mail info@SAMTEC.com code 55322

DESCRIPTION:
MINI POWER COMBO CABLE ASSEMBLY

DWG. NO.
MPCC-X-XX-X-X-XX-XX.XX-X-XXX

BY: D.SCHMELZ 05/26/2010 SHEET 2 OF 3

IN-PROCESS 1
 (APPLIES TO -S END OPTION ONLY)
 (TO BE BUILT DOUBLE-ENDED INITIALLY FOR E-TEST,
 THEN CUT IN HALF AND TRIMMED TO LENGTH)

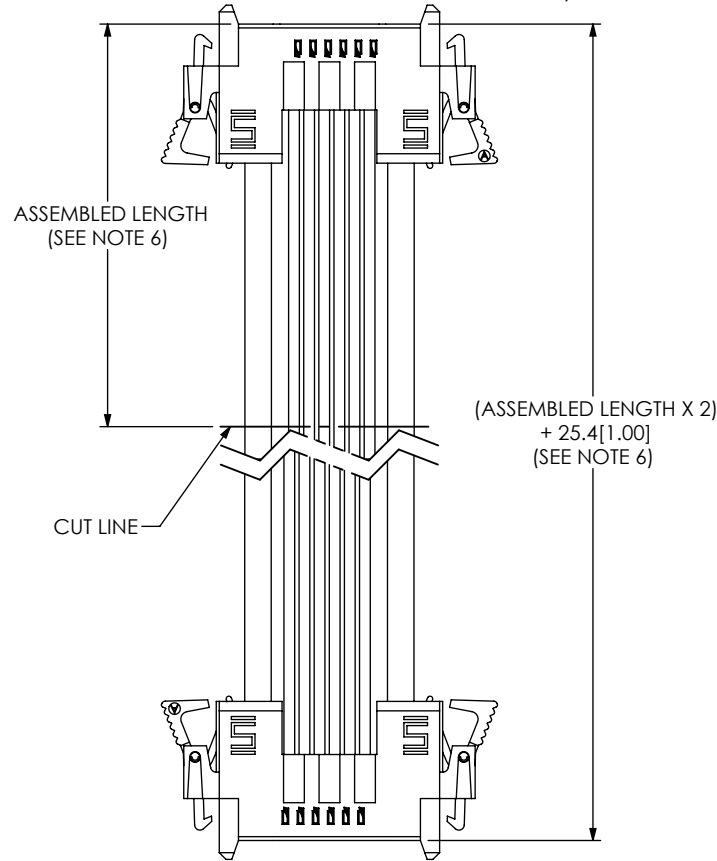

TABLE 1

LEAD STYLE	PWR/SIG	AWG	DWC-XX-10-XXX	CONTACT
44	PWR	14	DWC-14-10-XXX	C-246-01-X
	SIG	24	DWC-24-10-XXX	C-281-2426-X
46	PWR	14	DWC-14-10-XXX	C-246-01-X
	SIG	26	DWC-26-10-XXX	C-281-2426-X
48	PWR	14	DWC-14-10-XXX	C-246-01-X
	SIG	28	DWC-28-10-XXX	C-281-2830-X
40	PWR	14	DWC-14-10-XXX	C-246-01-X
	SIG	30	DWC-30-10-XXX	C-281-2830-X
64	PWR	16	DWC-16-10-XXX	C-246-01-X
	SIG	24	DWC-24-10-XXX	C-281-2426-X
66	PWR	16	DWC-16-10-XXX	C-246-01-X
	SIG	26	DWC-26-10-XXX	C-281-2426-X
68	PWR	16	DWC-16-10-XXX	C-246-01-X
	SIG	28	DWC-28-10-XXX	C-281-2830-X
60	PWR	16	DWC-16-10-XXX	C-246-01-X
	SIG	30	DWC-30-10-XXX	C-281-2830-X

F:\DWG\MISC\MKTG\MPCX-X-XX-X-X-XX-XX-X-XXX-MKT.SLDDRW

PROPRIETARY NOTE
 * THIS DOCUMENT CONTAINS CONFIDENTIAL AND PROPRIETARY INFORMATION AND ALL DESIGN, MANUFACTURING, REPRODUCTION, USE, PATENT RIGHTS AND SALES RIGHTS ARE EXPRESSLY RESERVED BY SAMTEC, INC. THIS DOCUMENT SHALL NOT BE DISCLOSED, IN WHOLE OR PART, TO ANY UNAUTHORIZED PERSON OR ENTITY NOR REPRODUCED, TRANSFERRED OR INCORPORATED IN ANY OTHER PROJECT IN ANY MANNER WITHOUT THE EXPRESS WRITTEN CONSENT OF SAMTEC, INC.

DO NOT SCALE DRAWING

SHEET SCALE: 1.5:1



520 PARK EAST BLVD, NEW ALBANY, IN 47150
 PHONE: 812-944-6733 FAX: 812-948-5047
 e-Mail info@SAMTEC.com code 55322

DESCRIPTION:
 MINI POWER COMBO CABLE ASSEMBLY

DWG. NO.
 MPCC-X-XX-X-X-XX-XX.XX-X-XXX

BY: D.SCHMELZ 05/26/2010 SHEET 3 OF 3