

Distributed by:

JAMECO[®]
ELECTRONICS

www.Jameco.com ♦ 1-800-831-4242

The content and copyrights of the attached
material are the property of its owner.

Jameco Part Number 1869189

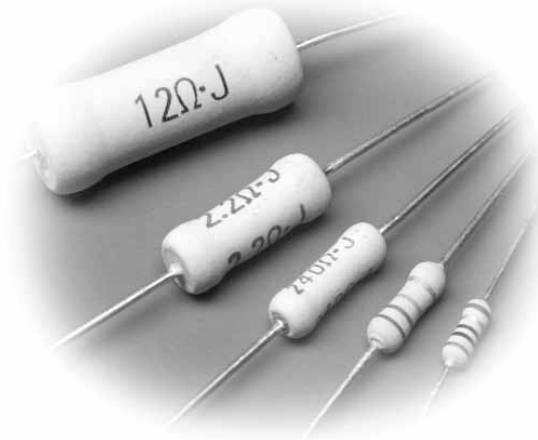

features

- Coated with UL94V0 flameproof material
- Suitable for automatic machine insertion
- Marking: Pink body color with color-coded bands or alpha-numeric black marking
- Products with lead-free terminations meet EU RoHS and China RoHS requirements

dimensions and construction

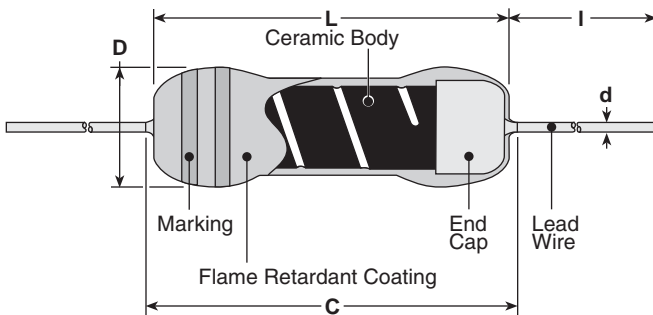

Type	Dimensions inches (mm)				
	L	C (max.)	D	d (nom.)	I
MOS1/2 MOSX1/2	.244±.02 (6.2±0.5)	.280 (7.1)	.098±.02 (2.5±0.5)	.024 (0.6)	.945 Min. (24.0 Min.)
MOS1 MOSX1	.354±.039 (9.0±1.0)	.437 (11.1)	.118±.02 (3.0±0.5)	.031 (0.8)	
MOS2 MOSX2	.472±.039 (12.0±1.0)	.591 (15.0)	.157±.02 (4.0±0.5)		
MOS3 MOSX3	.610±.039 (15.5±1.0)	.709 (18.0)	.236±.039 (6.0±1.0)		1.18±.118 (30.0±3.0)
MOS5 MOSX5	.965±.039 (24.5±1.0)	1.10 (28.0)	.354±.039 (9.0±1.0)		1.50±.122 (38.0±3.1)

ordering information

New Part #	MOS	1/2	C	T52	A	103	J
Type	MOS MOSX	Power Rating	Termination Material	Taping and Forming	Packaging	Nominal Resistance	Tolerance
		1/2: 0.5W 1: 1W 2: 2W 3: 3W 5: 5W	C: SnCu (Other termination styles available, contact factory for options)	Axial: T26, T52, T521, T631 Stand-off Axial: L52, L521, L631 Radial: VTP, VTE, GT, GT4 L, U, M Forming	A: Ammo R: Reel	±2%, ±5%: 2 significant figures + 1 multiplier "R" indicates decimal on value <10Ω ±1%: 3 significant figures + 1 multiplier "R" indicates decimal on value <100Ω	F: ±1% G: ±2% J: ±5%

For further information on packaging, please refer to Appendix C.

reduced size metal oxide power type leaded resistor

applications and ratings

Part Designation	Power Rating @ 70°C	Minimum Dielectric Withstanding Voltage	T.C.R. (ppm/°C) Max.	Resistance Range			Absolute Maximum Working Voltage	Absolute Maximum Overload Voltage	Operating Temperature Range
				E-96 (F±1%)	E-24 (G±2%)	E-24 (J±5%)			
MOS1/2	0.5W	400V	±300	10Ω - 47kΩ	10Ω - 47kΩ	10Ω - 47kΩ	300V	600V	-55°C to +200°C
MOS1	1.0W	500V		10Ω - 68kΩ	10Ω - 68kΩ	10Ω - 100kΩ	350V		
MOS2	2.0W			10Ω - 100kΩ	10Ω - 100kΩ			500V	
MOS3	3.0W	700V		—	10Ω - 100kΩ	10Ω - 100kΩ	E = √P x R		
MOS5	5.0W	800V		0.2Ω - 9.1Ω	0.22Ω - 9.1Ω	0.1Ω - 9.1Ω		E = √P x R	
MOSX1/2	0.5W	400V					—		
MOSX1	1.0W	500V		—	—	—		E = √P x R	
MOSX2	2.0W						700V		
MOSX3	3.0W	700V		—	—	—	E = √P x R	E x 2.5	
MOSX5	5.0W	800V	—						—

environmental applications

Derating Curve

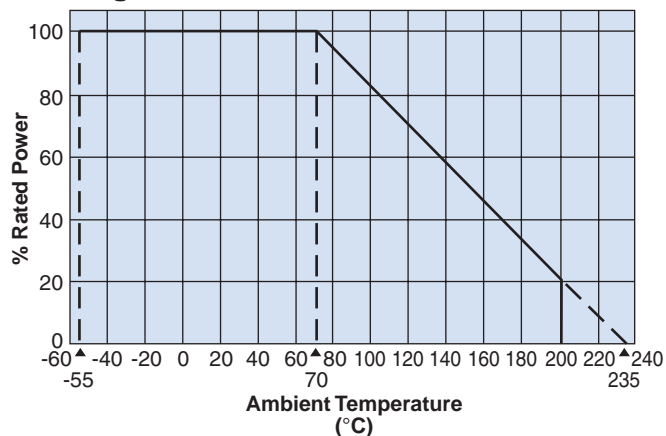

Surface Temperature Rise

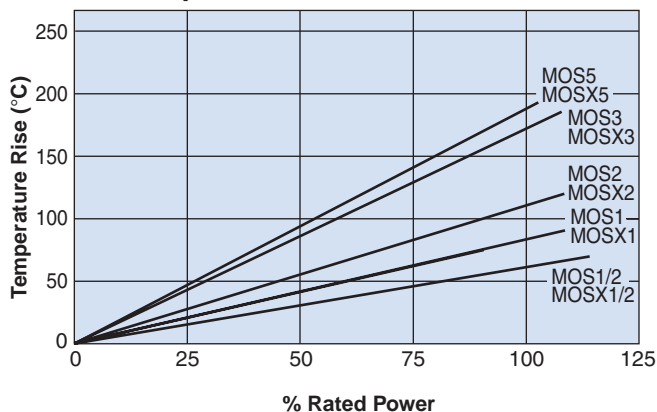

Performance Characteristics

Parameter	Requirement
Temperature Coefficient	±300ppm/°C
Short Time Overload	±2.0%
Resistance to Solder Heat	±1.0%
Moisture Resistance	±5.0%
Load Life	
Temperature Cycling	
Vibration	±1.0%
Shock	
Terminal Strength (Lead Pull)	5 # Minimum
Current Noise	<0.1μv/v/decade
Voltage Coefficient	<20ppm/v
Low Temperature Operation	±1.0%

axial tape (ammo pack)

Type	Dimension (mm)			Axial Tape							
	L	D	d	T26A AMMO	T52A AMMO	T52R REEL	T521A AMMO	T521R REEL	T631A AMMO	T631R REEL	
MFS	1/4	3.2	1.7	0.45	3000	3000	5000				
	1/2	6.3	2.3	0.6	2000	5000	5000				
MF	1/4	6.3	2.3	0.6	2000	5000	5000				
	1/2	9.6	3.5	0.6		2000	4000				
	1	15.5	5.5	0.8					1000		
RNS	1/8	6.35	2.41	0.64		2000	5000				
	1/4	9.5	3.3	0.64			2000				
	1/2	13.5	3.5	0.6					4000		
MO(X)	1/2	9.0	3.5	0.7		2000(L)	4000(L)				
	1	11.5	4.0	0.8		2000	2000	1000(L)	1000(L)	2000(L)	2000
	2	15.5	6.0	0.8				1000(L)	1000	1000(L)	1000(L)
MOS(X)	1/2	6.5	2.5	0.6	2000	2000	5000				
	1	9.0	3.0	0.8		2000(L)	4000				
	2	12.0	4.0	"	2000	1000	2000	1000(L)	1000		
	3	15.5	6.0	"				500(L)*	1000	1000(L)	1000(L)
SPR	1/4	3.3	1.7	0.45	2000	2000	5000				
	1/2	6.2	2.5	0.6	2000	2000(L)	5000(L)				
	1	9.0	3.5	0.8		2000(L)	4000(L)				
	2	12.0	4.2	"		1000	2000	1000(L)*	1000		
	3	15.5	6.0	"				500	1000	1000(L)*	1000(L)
CFS	1/4	3.2	1.7	0.45	5000	5000	5000				
	1/2	6.3	2.85	0.6	2000	2000	4000				
CF	1/4	6.1	2.3	0.6	2000	5000	5000				
	1/2	8.5	3.0	0.7		4000	4000				
CFP	1/4	6.1	2.3	0.6	2000	2000(L)	5000				
	1/2	8.5	3.0	0.7		2000(L)	4000				
Z	16Z	3.2	1.7	0.45	5000	3000	5000				
	25Y	5.8	2.2	0.6	2000	5000	5000				
	25Z	6.1	2.3	0.6	2000	5000	5000				
J	1/6Z	3.4	1.7	0.5	2000	2000	5000				
	1/4Z	6.5	2.3	0.6	2000	2000	5000				
JL	5	52.0		0.5		10000					
	6	52.0		0.6	5000	10000	10000				
	8	52.0		0.8		10000	10000				
LT	1/6	3.2	1.7	0.45	3000	3000	5000				
	1/4	6.3	2.3	0.6	2000	2000	5000				
RC	1/4	6.3	2.4	0.6		1000	5000				
	1/2	9.5	3.6	0.7		1000	3000				
RCR	16	3.2	1.7	0.45	5000	3000					
	25	6.3	2.5	0.6	2000	2000	5000				
	50(+)	9.5	3.5	0.7		2000	3000				
	60	9.5	3.5	0.7		2000					
	75	12	3.0	0.8		1000					
	100	15.5	3.0	0.8				500		2000	
SDT101	A	4.0	1.6	0.4	4000	4000					
	B	4.0	1.5	0.4	4000	4000					
SA05		3.8	1.8	0.5		2000					

Remarks: Weight is for T52 & Marking
Marking (L) : T & LT Types
Non Marking: T Type Only

Packaging

(1) AMMO PACK (SYMBOL : A)

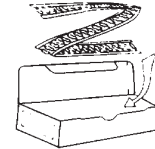

(2) REEL (SYMBOL : R)

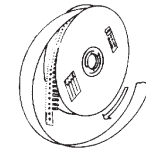

Remarks: Weight is for T52 & Marking
Marking (L) : T & LT Types
Non Marking: T Type Only

Specifications given herein may be changed at any time without prior notice. Please confirm technical specifications before you order and/or use.

3/01/07

axial tape (ammo pack)

Type		Dimension (mm)			Axial Tape						
		L	D	d	T26A AMMO	T52A AMMO	T52R REEL	T521A AMMO	T521R REEL	T631A AMMO	T631R REEL
PCF	1/2	9.0	3.5	0.7			2000				
	1	16.5	5.5	0.8							1000
	2	19.0	7.0	0.8							500
CW	1/4	3.3	1.9	0.45	2000	3000					
	1/2	6.5	2.5	0.6		2000					
	1	9.5	3.5	0.8		1000					
	2	13.0	4.0	0.8		1000	2000	2000			
	3	15.0	6.0	0.8				500	1000	1000	
	5	24.0	9.0	0.8							

Remarks: Weight is for T52 & Marking
Marking (L) : T & LT Types
Non Marking: T Type Only

Packaging

(1) AMMO PACK (SYMBOL : A)

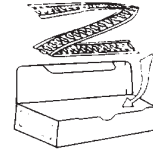

(2) REEL (SYMBOL : R)

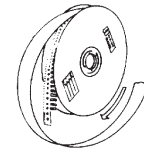

Remarks: Weight is for T52 & Marking
Marking (L) : T & LT Types
Non Marking: T Type Only

T-Type

Type	Dimensions (mm)			
	W	P	A	l ₁ -l ₂
T26	26	5.00±0.3	39±1.0	0.2max.
	26	5.00±0.3	39±1.0	1.0max.
T52	52±1	5.08±0.38	65±1.0	1.0max.
T521	52±1	10.16±0.8	65±1.0	1.0max.
T631	63±1	10.16±0.8	—	1.0max.

Note: Accumulated pitch
Pitch 5.00mm...250.0±2mm/50 pitch
Pitch 5.08mm...101.6±3mm/20 pitch
Pitch 10.16mm...203.2±3mm/20 pitch

T-Type

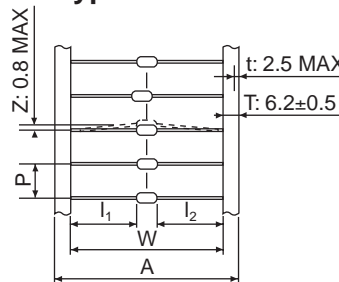

LT-Type

Type	Dimensions (mm)			
	H±1	w	d	h ₁ , h ₂
MOS1 T52 L25.5	25.5		0.8	
2 T521L36	36.0	1.20 ~ 1.45	0.8	
3 T631L42.5	42.5		0.8	
SPR 1/2 T52 L26	26.0	1.17~1.40	0.65	h ₁ -h ₂
1 T52 L25.5	25.5		0.8	≤1
2 T521L36	36.0	1.20 ~ 1.45	0.8	
3 5631L42.5	42.5		0.8	
MO 1 T521L36.5	36.5		0.8	
MO 2 T631L42.5	42.5		0.8	
CW 1 T52 L27.5	27.5	1.20 ~ 1.40	0.8	
CW 1/2 T52 L26	26.0	1.05 ~ 1.35	0.6	

LT-Type

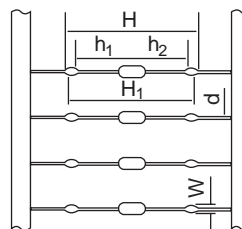

radial tape (ammo pack)

Type	Radial Style	Qty. kpcs	Weight g/kpcs	Dimension (mm)			
				L	D/H	d/W	
MFS	VT, MT	3000	130	3.2	1.7	0.45	
	VT, VTP, VTE	2000	320	6.3	2.3	0.6	
MF	1/4	VT, VTP, VTE	2000	0.6	6.3	7.1	2.3±0.3
RN26	2C	T	2000	260	5.0	2.54	5.00±0.3
	2E	T	2000	370	7.25	2.54	5.00±0.3
MOS (X)	1/2	VTP, VTE, GT	2000,1500	370	6.5	2.5	0.6
	1	VTP, GT	1500,1000	740	9.0	3.0	0.6, 0.8
	2	VTP, GT	1000,500	1080	12.0	4.0	0.65, 0.8
	3	GT	500	1820	15.5	6.0	0.8
SPR (X)	1/2	VTP, VTE, GT	2000,1500	370	6.5	2.5	0.6
	1	VTP, GT	1000	740	9.0	3.3	0.6, 0.8
	2	VTP, GT	1000,500	1080	12.0	4.2	0.65, 0.8
	3	GT	500	1820	15.5	6.0	0.8
	5						
J	1/4Z	VT, VTP	2000	360	6.5	2.3	0.6
CW3		GT	500	1820	7.5	30	15
CW2		VTP, GT	2000,500	1080	13.0	4.0	0.8
CW1		VTP	1000	740	9.5	3.5	0.8
CW1/2		VTP	2000	370	6.5	2.5	0.6
CFS	1/4	VT, MT, MHT	3000	240	3.2	1.7	0.45
CF	1/4	VT, VTP, VTE	2000,2500	360	6.1	2.3	0.6
CFS	1/2	VT	2000	800	6.3	7.1	2.85
BPR26		FT	500	790	8.5	13.0	4.0
BPR28		FT	500	1940	8.5	13.0	4.0
RNS	1/8	VT,VTP,VTE	2000	750	6.35	2.41	0.6

GT Style

KOA Type	RSS, SPR			
	1/2W	1W	2W	3W
F	5±0.5		7.5 ^{+0.8} _{-0.2}	
P	12.7±1.0		30±1.0	
P0	12.7±0.3		15±0.3	
H	6.5 ^{+0.6} ₋₀	6.5 ^{+1.0} ₋₀	7.5 ^{+1.0} ₋₀	8.5 ^{+1.0} ₋₀
H0	16±0.5		19±0.7	
A max.	12	14.5	17.5	21

CF, VT & MFS STYLE

KOA Type	Dimension	KOA Type	Dimension
P	12.7±1.0	H	16.0±0.5
P0	12.7±0.3	D0	∅4.0±0.2
P1	5.1±0.7	L	>11.0
F	2.5 ^{+0.3} ₋₀	l	>2.0
W	18.0 ^{+1.0} ₋₀	t	0.7±0.2
W0	<12.5	Δh	>2.0
W1	9.0 ^{+0.75} ₋₀	H1	5.0±0.5
W2	> 3.0	d	0.5

VT-Style

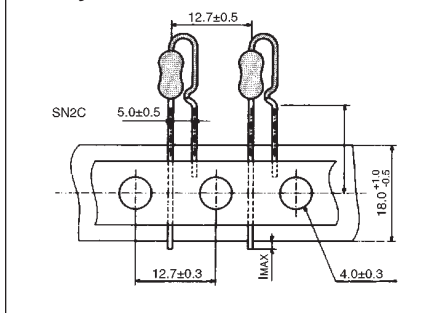

VTP-Style

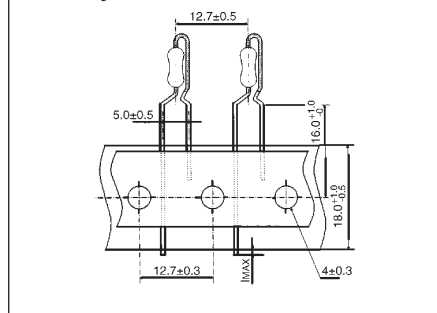

FT-Style

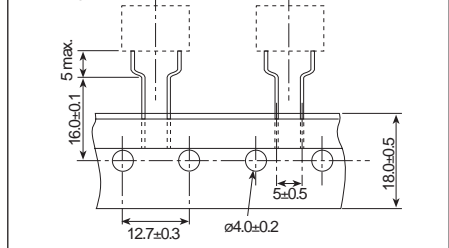

VTE-Style

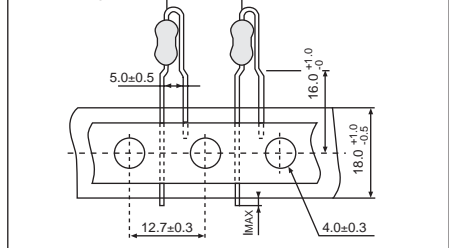

MT-Style

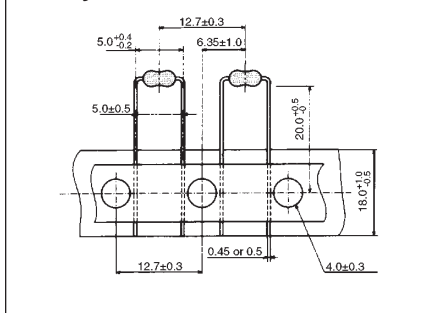

VT-Style (CFS 1/4 & MFS 1/4)

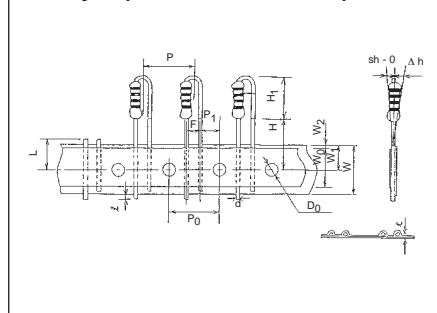

GT-Style

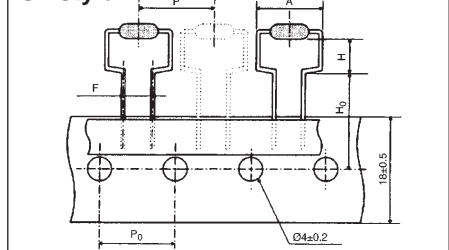

Specifications given herein may be changed at any time without prior notice. Please confirm technical specifications before you order and/or use.

3/01/07

discrete components (forming)

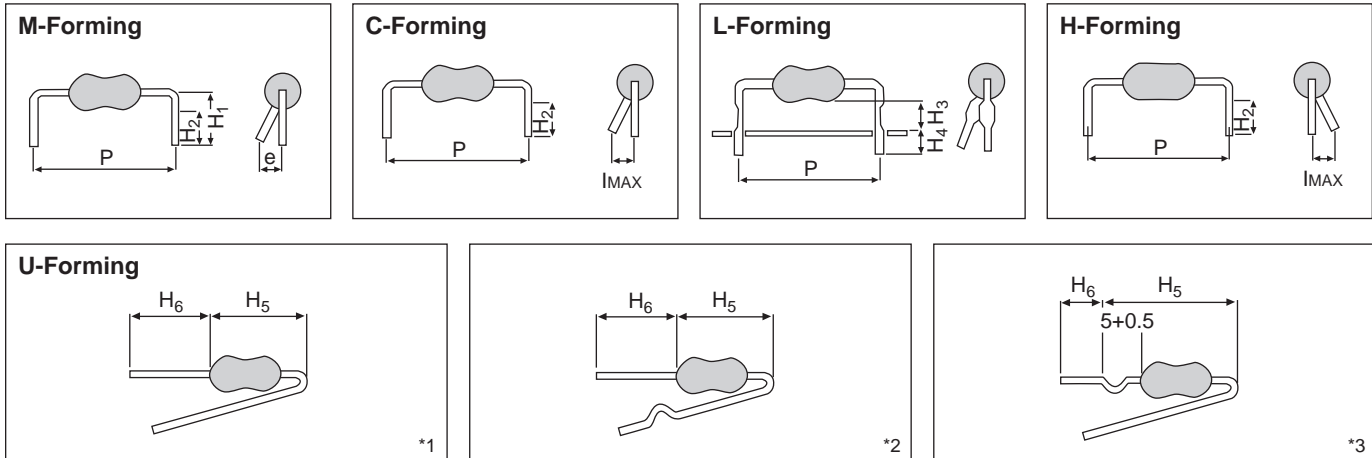

forming

Type	Dimensions (mm)			Weight g/100 pieces	M.C.L.-Forming Pitch (mm)										U-Forming		H-Forming	
	L	DWXH	d		5	7.5	10	12.5	15	20	25	27.5	30	35	Type	Style	Type	Style
MFS 1/4C	3.2	1.7	0.45	14	M		M								U	*1		
MFS 1/4	6.5	2.3	0.6	24	M		M	M							U	*2		
MFS 1/2	9.5	3.5	"	41				M	M									
MO 1	13.5	4.0	0.8	69					C,L	L					U	*3		
MO 2	15.5	6.0	"	142						L	C,L,M				U	*3		
MO 3	24.5	9.0	"	529								L	L					
MOS 1/2	6.5	2.5	0.6	23			C,L		L									
1	9.0	3.0	0.8	31				C,L	M,L						U	*3		
2	12.0	4.0	"	71					C,L	C,L					U	*3		
3	15.5	6.0	"	146						C,L	L				U	*3		
5	24.5	9.0	"	524								L	L					
SPR 1/2	6.5	2.5	0.6	23			C,L											
1	9.0	3.5	0.8	54				C,L	M,L						U	*3		
2	12.0	4.2	"	93					L	C,L					U	*3		
3	15.5	6.0	"	141						C,L	L				U	*3		
5	24.5	9.0	"	456								L	L					
CFS 1/4	3.2	1.7	0.45	12	M	M									U	*1		
CF 1/4	6.1	2.3	0.6	23			M	M	M						U	*2		
CFS 1/2	6.3	2.85	0.6	26			M								U	*2		
J 1/6Z	3.4	1.7	0.5	12		M												
1/4Z	6.5	2.3	0.6	19			M											
CFS 1/2	3.2	1.7	0.45	12	M,L													
CFP 1/4	6.1	2.3	0.6	23			M,L											
CW 1/2	6.5	2.5	0.6	24			L											
CW 1	9.5	3.5	0.8	56				L	L									
CW 2	13.0	4.0	0.8	84					L	L								
CW 3	15.0	6.0	0.8	160						L	L							
CW 5	25.0	9.0	0.8	440														
RC 1/4	6.3	2.4	0.6	12														H60
1/4	6.3	2.4	0.6	12								L	L					H62
1/2	9.5	3.6	0.028	13														H
LT 1/4	6.3	2.3	0.6	25			M	M							U	*1		
1/6	3.2	1.7	0.45	15	M													

Specifications given herein may be changed at any time without prior notice. Please confirm technical specifications before you order and/or use.

6/12/07

M-forming

Type			Dimensions (mm)		
			H1	H2	eMAX.
MFS	1/4	M5-5	—	5.0 ^{+1.0} _{-0.5}	1.5
MFS	1/2	M10-5	—	5.0 ^{+1.0} _{-0.5}	1.7
MFS	1/2	M12.5-10	10.0±1.0	—	"
MF		M12.5-10	"	—	2.0
MF		M15-10	"	—	"
CF	1/2	M5-5	5.9 ^{+1.0} _{-0.5}	5.0 ^{+1.0} _{-0.5}	1.5
CF	1/4	M10-6	6.0±1.0	4.8±1.0	1.7
	1/4	M12.5-6	"	"	"
J	1/6Z	M5-5	—	5.0-1.0	1.5
	1/4Z	M10-6	—	"	"
LT	1/6	M5-5	—	5.0	2.0
	1/4	M10	10.0	—	2.0
	1/4	M12.5	10.0	—	2.0

C-forming

Type			Dimensions (mm)
			H ₂ ±1.5
MO	1	C15	11.5
	2	C25	3.5
MOS	1/2	C10-5	5.0
	1	C12.5	4.0
	2	C20	13.5
SPR	3	C20	12.5
	1/2	C10	5.0
	1	C12.5	4.0
	2	C20	13.5
	3	C20	12.5

U-forming

Type			Dimensions (mm)	
			H ₅	H ₆
MO	1	U	20.0±2.0	31.0±1.5
	2	U	24.5±3.0	30.0±1.5
MOS	1	U	19.5±3.0	31.5±1.5
	2	U	22.0±3.0	29.5±1.5
	3	U	24.5±3.0	30.0±1.5
SPR	1	U	19.5±3.0	31.5±1.5
	2	L15	22.0±3.0	29.5±1.5
	3	L15	24.5±3.0	30.0±1.5
CF	S 1/4	U	5.5 MAX.	15.0±1.0
	1/4	UCL	10.5 MAX.	10.0±1.0
LT	1/4	U	9.5 MAX.	30.0±3.0

H-forming

Type			Dimensions (mm)		
			H1	H2	eMAX.
RC	1/4	H60	10.0	5.0	1.5
	1/4	H62	12.5	5.0	"
	1/2	H	15.0	5.0	1.8

L-forming

Type			Dimensions (mm)	
			H3±1	H4
MO	1/2	L12.5	6.5	4.0±1.0
	1	L15	7.0	4.0±1.0
	1	L20	4.8	4.0±1.0
	2	L20	8.0	4.0±1.0
	2	L25	7.0	4.0±1.0
	3	L30	8.5	4.0±1.0
	3	L35	5.5	4.0±1.0
	MOS	1/2	L10	5.3
1		L12.5	7.0	4.0±1.0
1		L15	6.5	4.0±1.0
2		L15	7.0	4.0±1.0
2		L20	9.0	4.0±1.0
3		L20	8.0	4.0±1.0
3		L25	7.0	4.0±1.0
5		L30	8.5	4.0±1.0
5		L35	5.5	4.0±1.0
SPR		1/2	L10	5.3
	1	L12.5	6.5	4.0±1.0
	1	L15	5.3	4.0±1.0
	2	L15	7.0	4.0±1.0
	2	L20	9.0	4.0±1.0
	3	L20	8.0	4.0±1.0
	3	L25	7.0	4.0±1.0
	5	L30	8.5	4.0±1.0
	5	L35	5.5	4.0±1.0
	CW	1/2	L10	5.3
1		L12.5	6.5	4.5±0.5
1		L15	5.3	4.5±0.5
2		L15	7.0	4.5±0.5
2		L20	8.0	4.5±0.5
3		L20	8.0	4.0±0.5
3		L25	7.0	4.5±0.5
5		L30	8.5	4.5±0.5
5		L35	5.5	4.5±0.5

stick (magazine) case

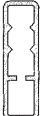
Type	Resistor Networks	
	RKL, RKC	RKL, RKC
Magazine Symbol	STP	STB
Sectional View		
W x H x L (mm)	5.0 x 11.0 12.5 x 508	3.8 x 13.4 x 580
Quantity (pcs.)	13 - 46	15 - 54
Weight (g)	30	30

SIP resistor network taping—TBA style

For KOA type RKL & RKC networks with 4 to 9 pins

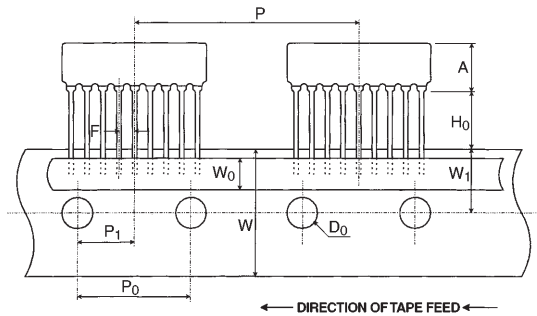

Leaded Resistors (TBA Style)

Type	Dimensions (mm)
A	RKL: 5.0 max.-RKC: 6.5 max.
P	25.4 ± 1.0
P ₀	12.7 ± 0.3
P ₁	6.35 ± 0.5
F	2.54 ± 0.3
W	18.0 ± 0.5
W ₀	6.0 ± 0.5
W ₁	9.0 ± 0.5
H ₀	7.0 ± 0.5
D ₀	4.0 ± 0.3

SIP resistor network taping—TUA style

For KOA type RKL & RKC 10-pin networks

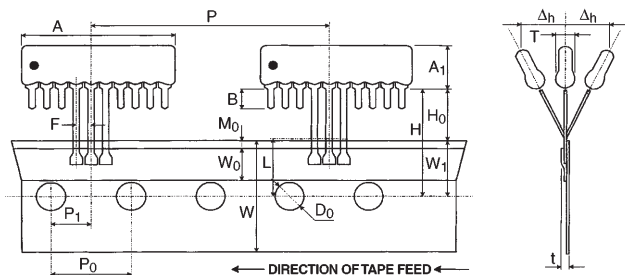

Leaded Resistors (TUA Style)

Type	Dimensions (mm)
A	25.40 max.
T	2.5 max.
A ₁	5.0 max.
B	3 ± 0.5
P	RKL: 25.4, RKC: 38.1±1.0
P ₀	12.7 ± 0.3
P ₁	6.35 ± 0.7
Δh	0 ± 2.0
W	18 ± 0.5
W ₀	6 ± 0.5
W ₁	9 ± 0.5
H	19.5 ± 0.5
H ₀	10.5 ± 0.5
D ₀	4 ± 0.3
t	0.7 ± 0.2
L	11 max.
M ₀	1.0 ± 1.0

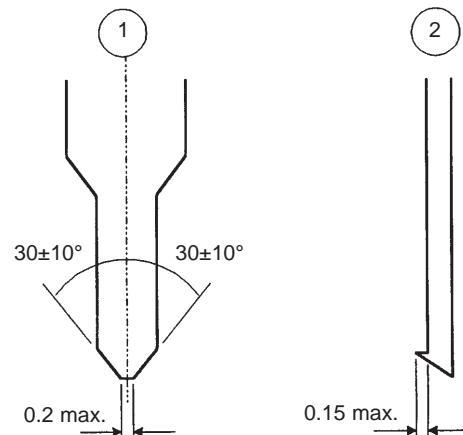

*21 Holes Length = 254 ± 1mm

Application: Universal radial lead component insertion machine

SIP resistor network taping—TPA style

For KOA type RKL & RKC networks with 4 to 9 pins

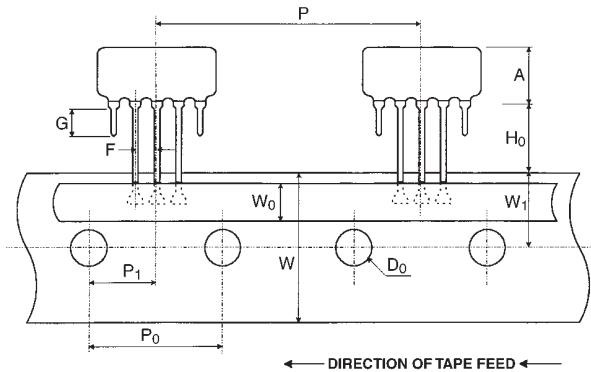

Leaded Resistors (TPA style)

Type	Dimensions (mm)
A	RKL: 5.0 max.-RKC: 6.5 max.
P	25.4 ± 1.0
P ₀	12.7 ± 0.3
P ₁	6.35 ± 0.5
F	2.54 ± 0.3
W	18.0 ± 0.5
W ₀	6.0 ± 0.5
W ₁	9.0 ± 0.5
H ₀	10.5 ± 0.5/1.0
D ₀	4.0 ± 0.3
G	3.0 ± 0.5

SIP resistor network taping—TPA style

For KOA TPA style taping

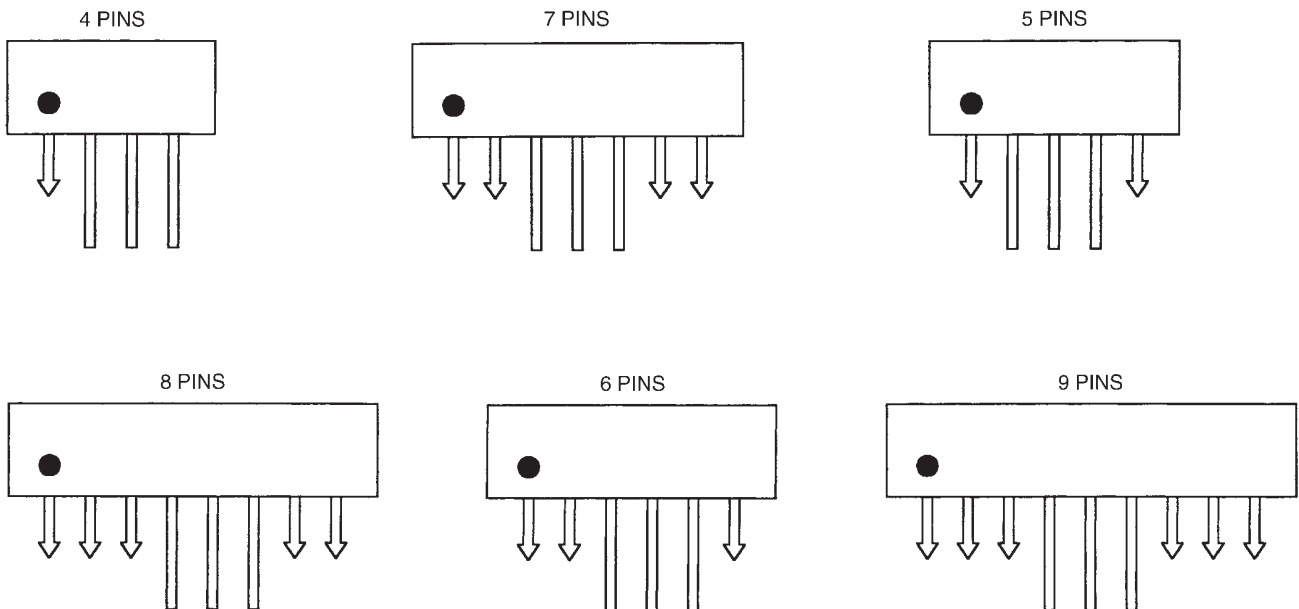

← DIRECTION OF TAPE FEED ←

SIP resistor network packaging—STP & STB style packaging for stick (magazine) case

Resistor Networks - RKL & RKC

Type RKC, RKL	STP Pieces Per Stick		STB Pieces Per Stick		Sticks Per Box STP & STB
	RKC	RKL	RKC	RKL	
4 Pin	46	48	54	55	50
5 Pin	37	38	42	44	50
6 Pin	31	32	34	37	50
7 Pin	27	27	30	31	50
8 Pin	23	24	26	27	50
9 Pin	21	21	23	24	50
10 Pin	19	19	21	22	50
11 Pin	19	19	19	20	50
12 Pin	15	16	18	18	50
13 Pin	14	—	16	—	50
14 Pin	13	—	15	—	50

Dimensions - mm (Inches)

Type	Length	Width	Height	
			RKL	RKC
STP	508 (20.0)	5.0 (0.20)	11.0 (0.43)	13.4 (0.53)
STB	580 (22.8)	3.8 (0.15)	12.5 (0.49)	13.4 (0.53)

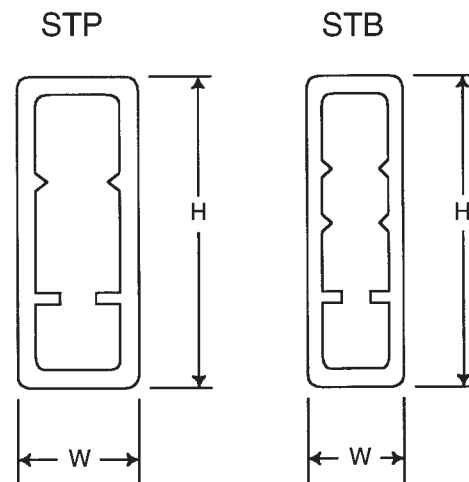

resistor networks

Resistor Color Code Chart

Color	Significant Figure	Multiplier	Tolerance
Silver	–	10^{-2}	+10%
Gold	–	10^{-1}	+5%
Black	0	1	–
Brown	1	10	+1%
Red	2	10^2	+2%
Orange	3	10^3	–
Yellow	4	10^4	–
Green	5	10^5	+0.5%
Blue	6	10^6	+0.25%
Violet	7	10^7	+0.10%
Gray	8	10^8	+0.05%
White	9	10^{-3*}	–

* The 10^{-3} Multiplier is not an “Industry Standard” Multiplier

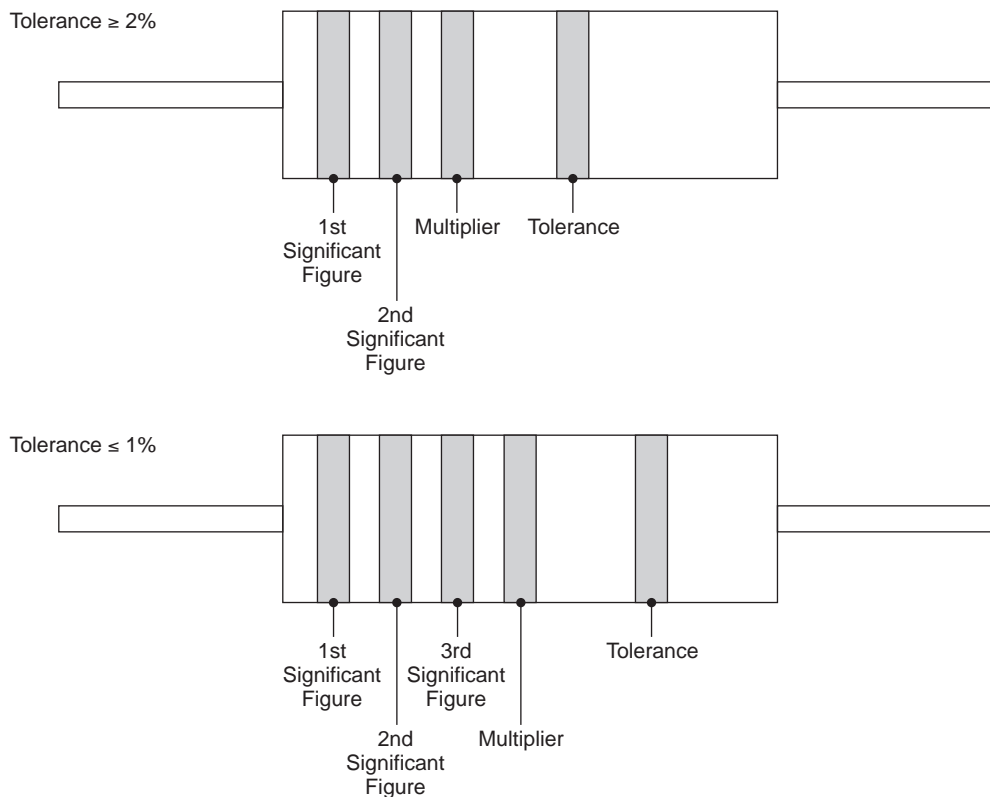

NVD—metal oxide varistor disc type

MH, GJ, MJ Style

KOA Type	Varistor Voltage	H Max. (mm)	Qty. /bag (pcs)	Weight g/100pcs
NVD05UCDMH	18-470V	13.5	200	30-80
NVD07UCDMH	18-470V	14.5	100	90-140
NVD10UCDGJ	22-470V	17.0	100	180-500
NVD14UCDGJ	22-390V	23.5	100	270-760
NVD14UCDGJ	430-470V	23.5	50	270-760
NVD05UCDMJ	22-470V	13.0	200	30-80
NVD07UCDMJ	22-470V	14.5	100	90-140
NVD10UBCDMJ	22-270V	17.5	100	180-220

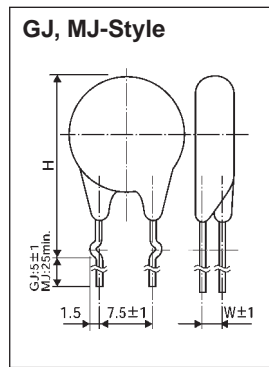
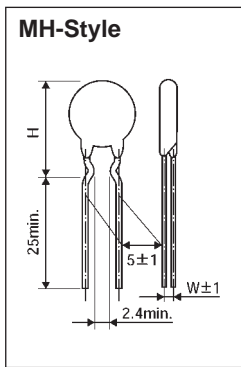

MH Style

Varistor Voltage (V)	W	Varistor Voltage (V)	W
22-56	1.7	240	1.2
68	1.9	270	1.5
82	1.0	330	1.7
100	1.6	360	1.9
120	1.8	390	2.0
150	2.1	430	2.2
200	1.0	470	2.4
220	1.1		

GJ, MJ Style

Varistor Voltage (V)	W (mm)				Varistor Voltage (V)	W (mm)			
	D05	D07	D10	D14		D05	D07	D10	D14
22-56	1.7	1.7	1.9	1.9	240	1.2	1.2	1.2	1.2
68	1.9	1.9	2.1	2.1	270	0.9	0.9	1.3	1.3
82	1.0	1.0	1.0	1.0	330	1.1	1.1	1.6	1.6
100	1.6	1.6	1.8	1.1	360	1.2	1.2	2.0	2.0
120	1.8	1.8	2.0	2.0	390	1.3	1.3	2.3	2.3
150	2.1	2.1	2.3	2.3	430	1.5	1.5	2.6	2.6
200	1.0	1.0	1.0	1.0	470	1.6	1.6	2.9	2.9
220	1.1	1.1	1.1	1.1					

MT, GHT Style

Type	Varistor Voltage (V)	ø Dmax. (mm)	ø d (mm)	F (mm)	Pkg. AMMO (pcs)	Weight g/AMMO
NVD05UCDMT	22-47V	7.0	0.6	5±1	2000	1240-1640
	56,68V	7.0	0.6	5±1	1500	1260
	82-150V	7.0	0.6	5±1	2000	1440
	200-470V	7.5	0.6	5±1	1000	790-990
NVD07UCDMT	22-47V	9.0	0.6	5±1	2000	2040-2440
	56,68V	9.0	0.6	5±1	1500	1860
	82-150V	9.0	0.6	5±1	2000	2040
	200-470V	9.5	0.6	5±1	1000	1190-1590
NVD10UBCDMT	22-150V	12.0	0.6	5±1	1000	1990-2390
	200,220V	12.0	0.6	5±1	1000	2290
NVD10UCDGHT	22-150V	12.0	0.8	7.5±1	2000	1980-2390
	200,220V	12.0	0.8	7.5±1	1000	2280
	240,270V	12.0	0.8	7.5±1	500	1260
	330-470V	12.5	0.8	7.5±1	500	1410-1660

KOA Type	Dimension	KOA Type	Dimension
øD	*	W ₂	3 Max.
ød	*	F	*
D ₀	4.0±0.2	F ₁	(5)
P	12.7±1.0	H	(17)
P ₀	12.7±0.3	H ₁	20 ^{+1.5} _{-1.0}
P ₁	6.35±1.3	Δh ₁	0±2.0
W	18.0 ⁺¹ _{-0.5}	Δh ₂	0±1.3
W ₀	15	t	0.6±0.3
W ₁	9.0±0.5	e	less than 1.0

* Refer to the following lists for øD, outside dia. of product, ød, lead dia. and F, distance between leads.

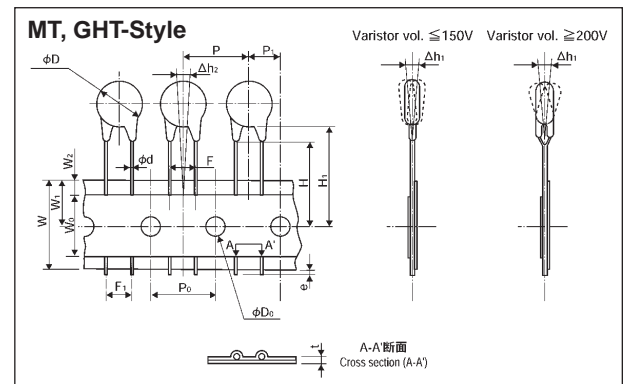

NVD—metal oxide varistor disc type (continued)

MHT Style

Type	Varistor Voltage (V)	ø Dmax. (mm)	ø d (mm)	F (mm)	Pkg. AMMO (pcs)	Weight g/AMMO
NVD05UCDMHT	22-47V	7.0	0.6	5.0±1	2000	1270-1670
	56,68V	7.0	0.6	5.0±1	1500	1280
	82-150V	7.0	0.6	5.0±1	2000	1470
	200-470V	7.5	0.6	5.0±1	1000	800-1000
NVD07UCDMHT	22-47V	9.0	0.6	5.0±1	2000	2070-2470
	56,68V	9.0	0.6	5.0±1	1500	1890
	82-150V	9.0	0.6	5.0±1	2000	2070
	200-470V	9.5	0.6	5.0±1	1000	1200-1600
NVD10UBCDMHT	22-220V	12.0	0.6	5.0±1	1000	2010-2410
	240,270V	12.0	0.6	5.0±1	500	1280

KOA Type	Dimension	KOA Type	Dimension
øD	*	W ₂	3 Max.
ød	0.6	F	5.0±1.0
D ₀	4.0±0.2	F ₁	(5)
P	12.7±1.0	H	16±0.5
P ₀	12.7±0.3	H ₁	(20)
P ₁	6.35±1.3	Δh ₁	0±2.0
W	18.0 ⁺¹ _{-0.5}	Δh ₂	0±1.3
W ₀	15	t	0.6±0.3
W ₁	9.0±0.5	e	less than 1.0

* Refer to the following list for øD, outside dia.

GJT, MJT Style

Type	Varistor Voltage (V)	ø Dmax. (mm)	ø d (mm)	F (mm)	H ₂ Max. (mm)	Pkg. AMMO (pcs)	Weight g/AMMO
NVD10UCDGT	22-220V	12.0	0.8	7.5±1	—	1000	2010-2410
	240,270V	12.0	0.8	7.5±1	—	500	1280
	330-470V	12.5	0.8	7.5±1	—	500	1430-1680
NVD05UCDMJT	22-47V	7.0	0.6	5±1	13.0	2000	1270-1670
	56,68V	7.0	0.6	5±1	13.0	1500	1280
	100,120V	7.0	0.6	5±1	13.0	2000	1470
	150V	7.5	0.6	5±1	13.0	2000	1470
	200-470V	7.5	0.6	5±1	13.0	1000	800-1000
NVD07UCDMJT	22-47V	9.0	0.6	5±1	14.5	2000	2070-2470
	56,68V	9.0	0.6	5±1	14.5	1500	1890
	100,120V	9.0	0.6	5±1	14.5	2000	2070
	150V	9.5	0.6	5±1	14.5	2000	2070
	200,470V	9.5	0.6	5±1	14.5	1000	1200-1600
NVD10UBCDMJT	22-220V	12.0	0.6	5±1	17.5	1000	2010-2410
	240-270V	12.5	0.6	5±1	17.5	500	1280

KOA Type	Dimension	KOA Type	Dimension
øD	*	W ₂	3 Max.
ød	0.8	F	7.5±1.0
D ₀	4.0±0.2	F ₁	(5)
P	12.7±1.0	H	16±0.5
P ₀	12.7±0.3	H ₁	(20)
P ₁	6.35±1.3	Δh ₁	0±2.0
W	18.0 ⁺¹ _{-0.5}	Δh ₂	0±1.3
W ₀	15	t	0.6±0.3
W ₁	9.0±0.5	e	less than 1.0

* Refer to the following list for øD, outside dia.

