

The RF Line

NPN Silicon

High-Frequency Transistors

Designed for low noise, wide dynamic range front-end amplifiers and low-noise VCO's. Available in a surface-mountable plastic packages. This Motorola series of small-signal plastic transistors offers superior quality and performance at low cost.

- High Gain-Bandwidth Product
 $f_T = 8.0 \text{ GHz (Typ) @ } 50 \text{ mA}$
- Low Noise Figure
 $NF_{\min} = 1.6 \text{ dB (Typ) @ } f = 1.0 \text{ GHz (MRF5711LT1, MRF571)}$
- High Gain
 $G_{NF} = 17 \text{ dB (Typ) @ } 30 \text{ mA/500 MHz (MMBR571LT1)}$
- High Power Gain
 $G_{pe} \text{ (matched)} = 13.5 \text{ dB (Typ) (MRF5711LT1)}$
- State-of-the-Art Technology
 Fine Line Geometry
 Ion-Implanted Arsenic Emitters
 Gold Top Metallization and Wires
 Silicon Nitride Passivation
- Available in tape and reel packaging options:
 T1 suffix = 3,000 units per reel

MMBR571LT1
MRF5711LT1

$I_C = 80 \text{ mA}$
LOW NOISE
HIGH-FREQUENCY
TRANSISTORS

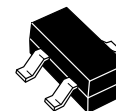

CASE 318-08, STYLE 6
SOT-23
LOW PROFILE
MMBR571LT1

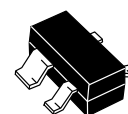

CASE 318A-05, STYLE 1
SOT-143
LOW PROFILE
MRF5711LT1

MAXIMUM RATINGS

Rating	Symbol	Value	Unit
Collector-Emitter Voltage	V_{CEO}	10	Vdc
Collector-Base Voltage	V_{CB0}	20	Vdc
Emitter-Base Voltage	V_{EBO}	3.0	Vdc
Collector Current — Continuous	I_C	80	mA
Total Device Dissipation @ $T_{\text{case}} = 75^\circ\text{C}$ Derate linearly above $T_{\text{case}} = 75^\circ\text{C}$ @	$P_{D(\text{max})}$	0.33 4.44	W mW/ $^\circ\text{C}$
Operating and Storage Temperature	T_{stg}	-55 to +150	$^\circ\text{C}$

THERMAL CHARACTERISTICS

Rating	Symbol	Max	Unit
Thermal Resistance, Junction to Case MRF5711LT1, MMBR571LT1	$R_{\theta JC}$	225	$^\circ\text{C/W}$
Maximum Junction Temperature	$T_{J\text{max}}$	150	$^\circ\text{C}$

DEVICE MARKING

MMBR571LT1 = 7X	MRF5711LT1 = 02
-----------------	-----------------

NOTE:

1. Case temperature measured on collector lead immediately adjacent to body of package.

ELECTRICAL CHARACTERISTICS ($T_A = 25^\circ\text{C}$ unless otherwise noted)

Characteristic	Symbol	Min	Typ	Max	Unit
----------------	--------	-----	-----	-----	------

OFF CHARACTERISTICS

Collector–Emitter Breakdown Voltage ($I_C = 1.0\text{ mA}$, $I_B = 0$)	$V_{(BR)CEO}$	10	12	—	Vdc
Collector–Base Breakdown Voltage ($I_C = 0.1\text{ mA}$, $I_E = 0$)	$V_{(BR)CBO}$	20	—	—	Vdc
Emitter–Base Breakdown Voltage ($I_E = 50\text{ }\mu\text{Adc}$, $I_C = 0$)	$V_{(BR)EBO}$	2.5	—	—	Vdc
Collector Cutoff Current ($V_{CB} = 8.0\text{ Vdc}$, $I_E = 0$)	I_{CBO}	—	—	10	μAdc

ON CHARACTERISTICS

DC Current Gain ($I_C = 30\text{ mAdc}$, $V_{CE} = 5.0\text{ Vdc}$)	h_{FE}	50	—	300	—
--	----------	----	---	-----	---

DYNAMIC CHARACTERISTICS

Collector–Base Capacitance ($V_{CB} = 10\text{ Vdc}$, $I_E = 0$, $f = 1.0\text{ MHz}$) ($V_{CB} = 6.0\text{ Vdc}$, $I_E = 0$, $f = 1.0\text{ MHz}$)	MMBR571LT1 MRF5711LT1,	C_{cb}	— —	0.7 0.75	1.0 1.0	pF
Current Gain–Bandwidth Product ($V_{CE} = 5.0\text{ Vdc}$, $I_C = 50\text{ mAdc}$, $f = 1.0\text{ GHz}$) ($V_{CE} = 8.0\text{ Vdc}$, $I_C = 50\text{ mAdc}$, $f = 1.0\text{ GHz}$)	MMBR571LT1 MRF5711LT1	f_T	— —	8.0 8.0	— —	GHz

FUNCTIONAL TESTS

Gain @ Noise Figure ($I_C = 10\text{ mAdc}$, $V_{CE} = 5.0\text{ Vdc}$) ($I_C = 10\text{ mA}$, $V_{CE} = 6.0\text{ Vdc}$)	MMBR571LT1 MRF5711LT1	$f = 0.5\text{ GHz}$ $f = 1.0\text{ GHz}$ $f = 1.0\text{ GHz}$	GNF	— — —	16.5 10.5 13.5	— — —	dB
Noise Figure ($I_C = 10\text{ mAdc}$, $V_{CE} = 5.0\text{ Vdc}$) ($I_C = 10\text{ mAdc}$, $V_{CE} = 6.0\text{ Vdc}$)	MMBR571LT1 MRF5711LT1	$f = 0.5\text{ GHz}$ $f = 1.0\text{ GHz}$ $f = 1.0\text{ GHz}$	NF	— — —	2.0 2.6 2.2	— — —	dB
Noise Figure ($V_{CE} = 6.0\text{ V}$, $I_C = 10\text{ mA}$, $f = 1.0\text{ GHz}$)	MRF5711LT1		NF_{min}	—	1.6	—	dB
Power Gain in $50\text{ }\Omega$ System ($V_{CE} = 6.0\text{ V}$, $I_C = 10\text{ mA}$, $f = 1.0\text{ GHz}$)	MRF5711LT1		$ S_{21} ^2$	9.0	10	—	dB

TYPICAL CHARACTERISTICS
MMBR571LT1

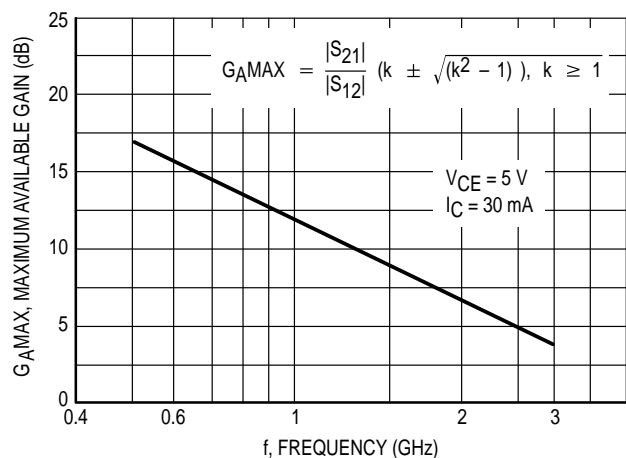

Figure 1. Maximum Available Gain versus Frequency

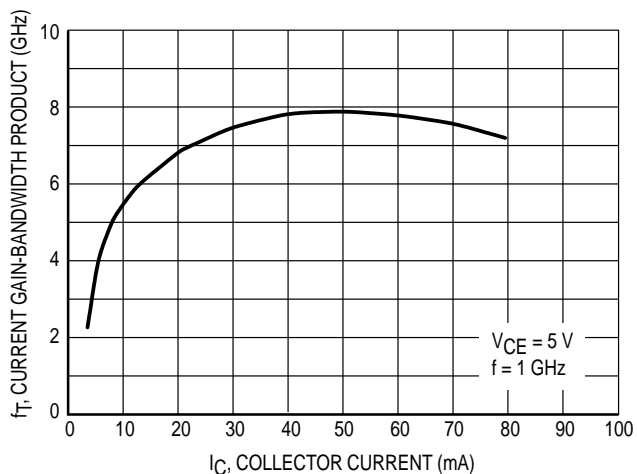

Figure 2. Current Gain–Bandwidth versus Collector Current @ 1.0 GHz

**TYPICAL CHARACTERISTICS
MMBR571LT1**

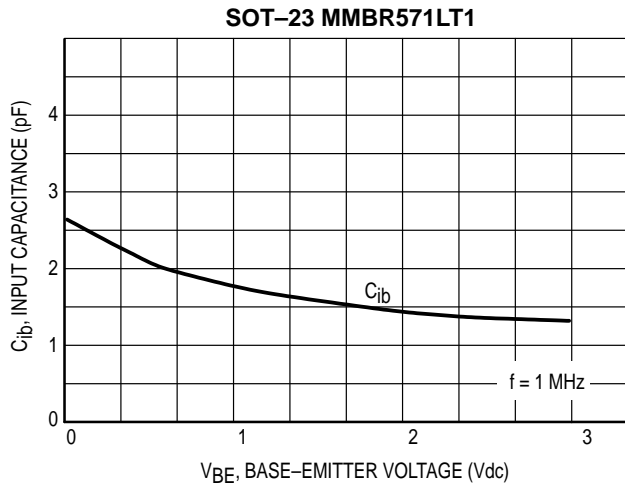

Figure 3. Input Capacitance versus Emitter Base Voltage

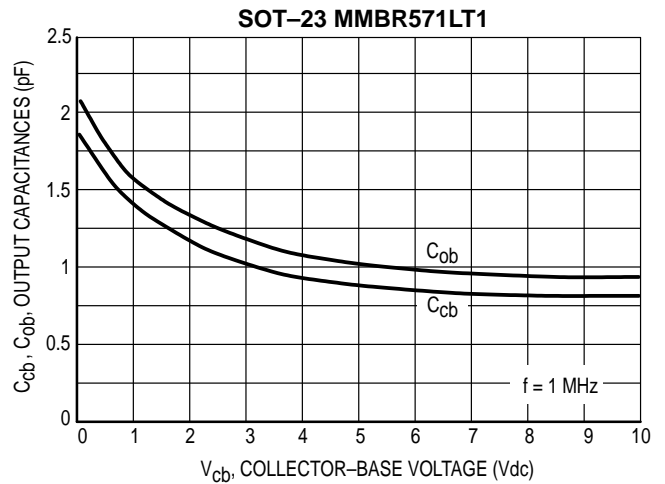

Figure 4. Output Capacitances versus Collector-Base Voltage

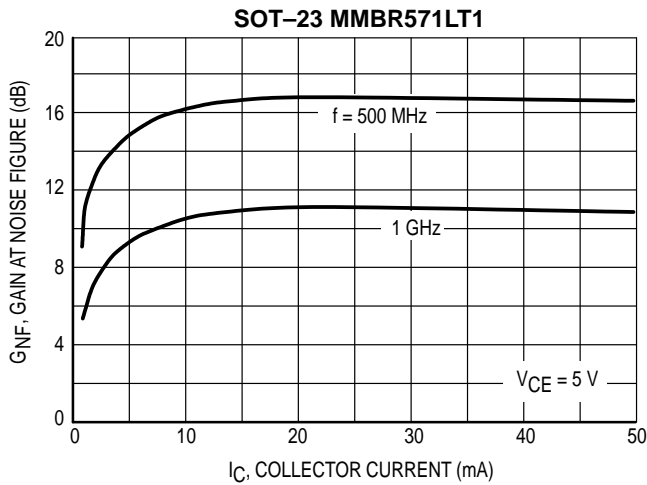

Figure 5. Gain at Noise Figure versus Collector Current

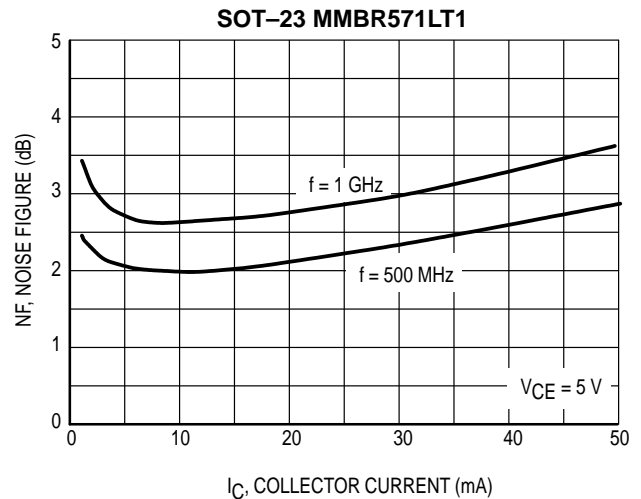

Figure 6. Noise Figure versus Collector Current

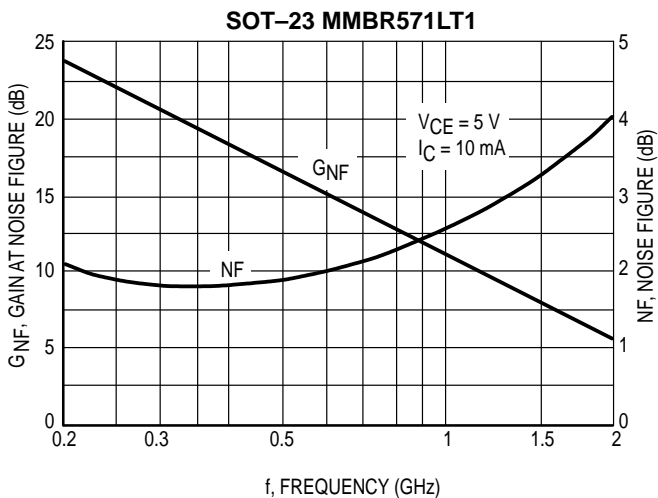

Figure 7. Gain at Noise Figure and Noise Figure versus Frequency

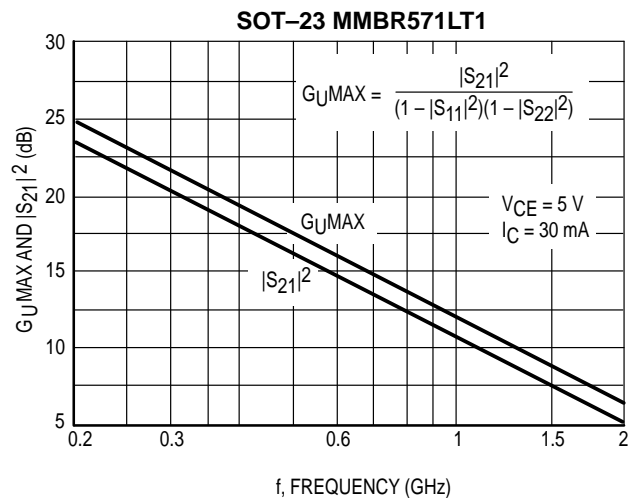

Figure 8. Maximum Unilateral Gain and Insertion Gain versus Frequency

TYPICAL CHARACTERISTICS
MRF5711LT1

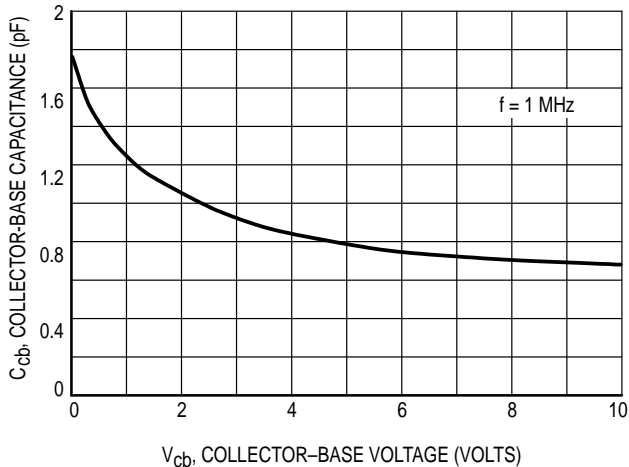

Figure 9. Collector-Base Capacitance versus Collector-Base Voltage

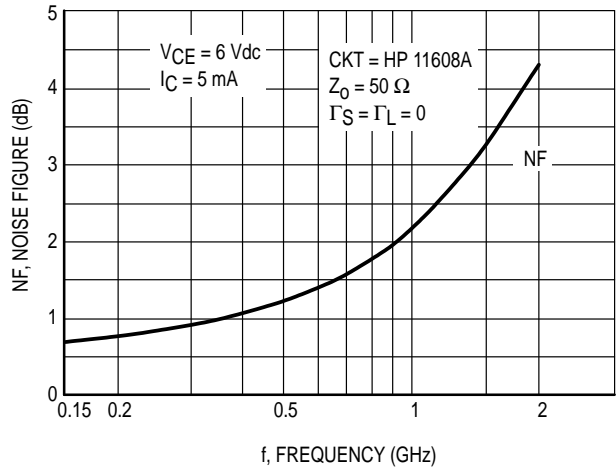

Figure 10. 50 Ω Noise Figure versus Frequency

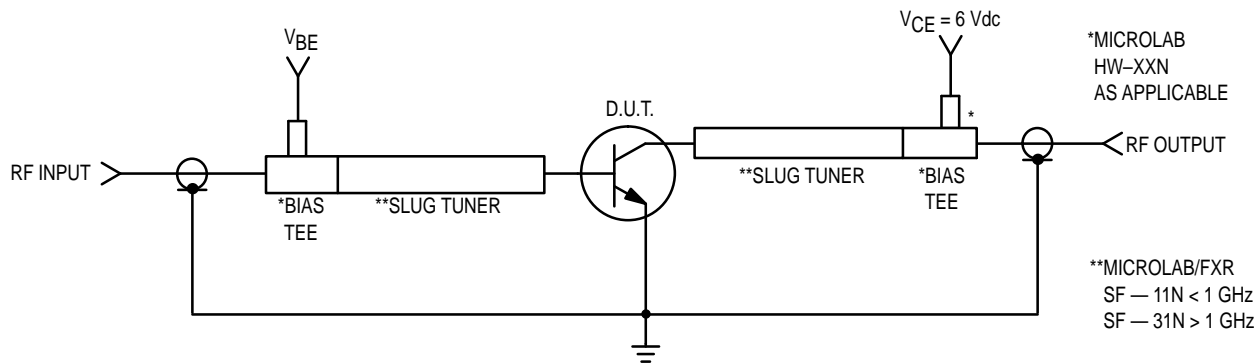

Figure 11. Functional Circuit Schematic

TYPICAL CHARACTERISTICS MRF5711LT1

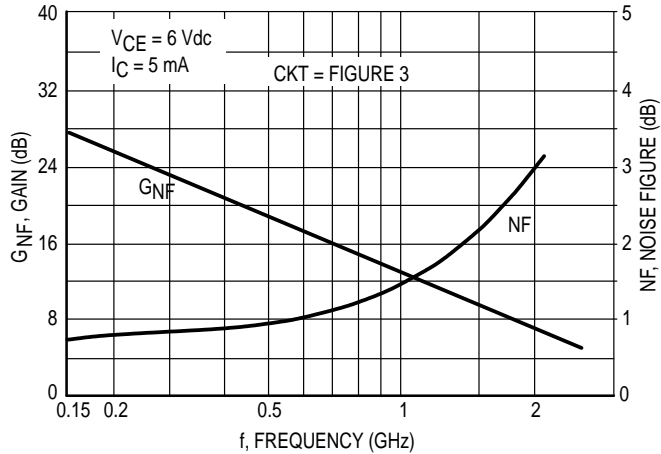

Figure 12. Gain and Noise Figure versus Frequency

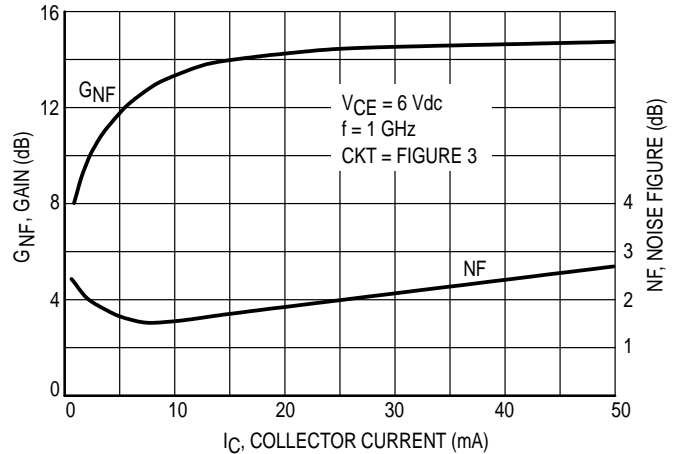

Figure 13. Gain and Noise Figure versus Collector Current

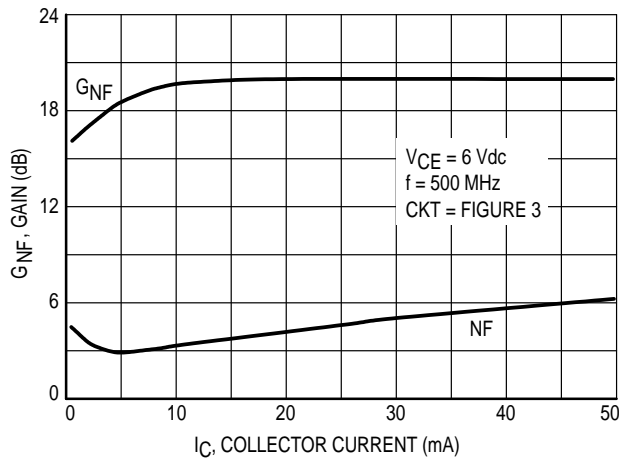

Figure 14. Gain and Noise Figure versus Collector Current

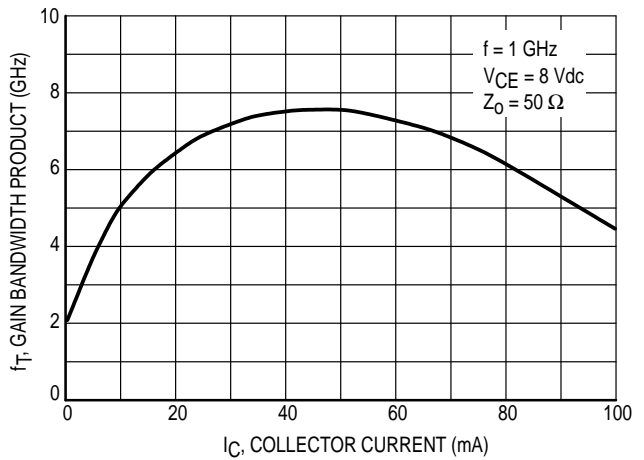

Figure 15. Gain Bandwidth Product versus Collector Current

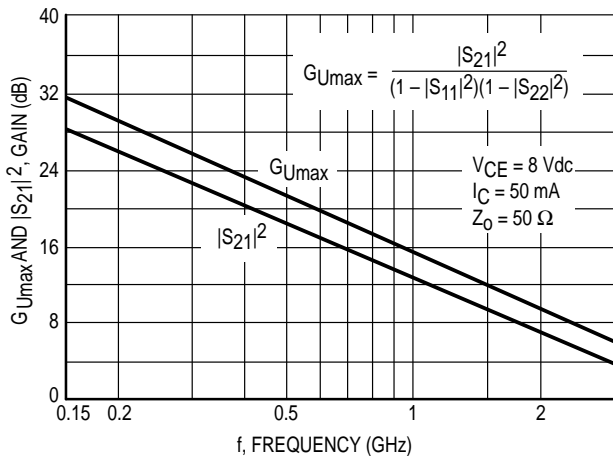

Figure 16. G_{UmAx} and $|S_{21}|^2$ versus Frequency

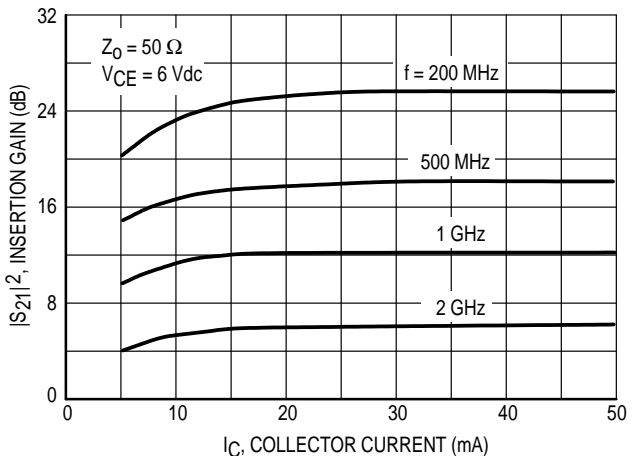

Figure 17. Insertion Gain versus Collector Current

MMBR571LT1

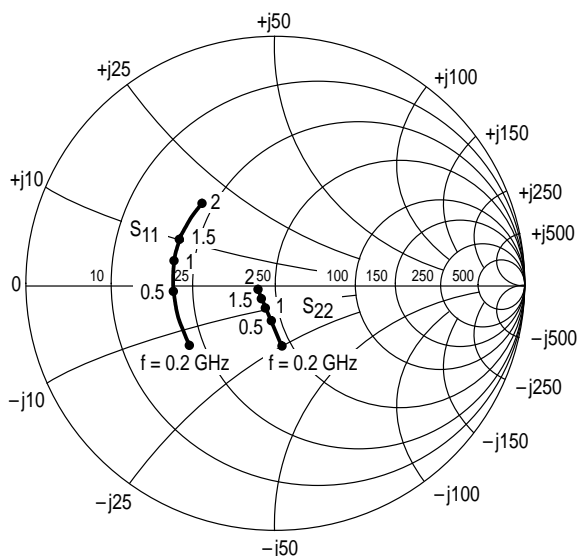

Figure 18. Input/Output Reflection Coefficients versus Frequency
 VCE = 5.0 V, IC = 30 mA

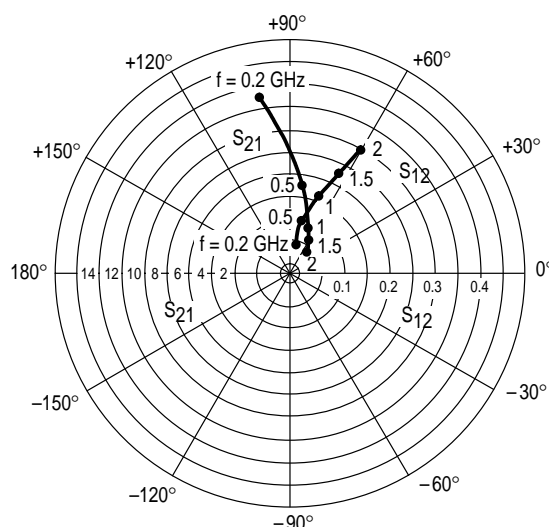
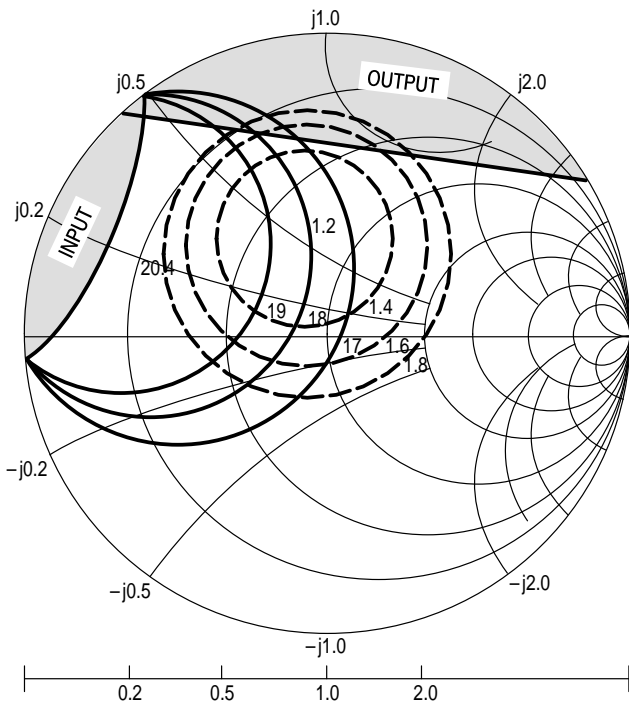

Figure 19. Forward/Reverse Transmission Coefficients versus Frequency
 VCE = 5.0 V, IC = 30 mA

VCE (Volts)	IC (mA)	f (MHz)	S11		S21		S12		S22	
			S11	φ	S21	φ	S12	φ	S22	φ
5.0	5.0	200	0.68	-82	8.41	126	0.07	53	0.61	-45
		500	0.52	-142	4.62	93	0.10	46	0.35	-60
		1000	0.50	179	2.57	72	0.14	53	0.26	-71
		1500	0.51	161	1.82	57	0.19	58	0.24	-77
		2000	0.52	143	1.48	45	0.24	59	0.22	-86
	15	200	0.46	-125	13.65	108	0.05	60	0.35	-73
		500	0.43	-169	6.03	86	0.09	66	0.17	-94
		1000	0.44	168	3.20	72	0.16	67	0.14	-111
		1500	0.45	152	2.21	58	0.22	64	0.11	-118
		2000	0.46	137	1.80	48	0.29	59	0.10	-131
	30	200	0.42	-148	14.79	102	0.04	68	0.26	-87
		500	0.41	-177	6.31	84	0.09	72	0.14	-115
		1000	0.42	165	3.35	71	0.16	70	0.12	-135
		1500	0.44	151	2.29	59	0.23	65	0.11	-144
		2000	0.44	135	1.84	48	0.30	60	0.10	-157
	50	200	0.41	-159	15.14	98	0.04	73	0.21	-96
		500	0.42	179	6.38	83	0.09	75	0.13	-124
		1000	0.43	163	3.35	70	0.16	71	0.12	-143
		1500	0.44	148	2.32	58	0.23	66	0.10	-151
		2000	0.45	134	1.84	48	0.30	60	0.09	-163

Table 1. MMBR571LT1 Common Emitter S-Parameters



$V_{CE} = 5\text{ V}$
 $I_C = 10\text{ mA}$
 □ = Area of Instability

f (GHz)	NF OPT	Γ_{MS}	NF OPT	Rn	K
0.5	1.20 dB	0.36	104°	7	0.63

Figure 20. MRF5711LT1 Constant Gain and Noise Figure Contours (f = 0.5 GHz)

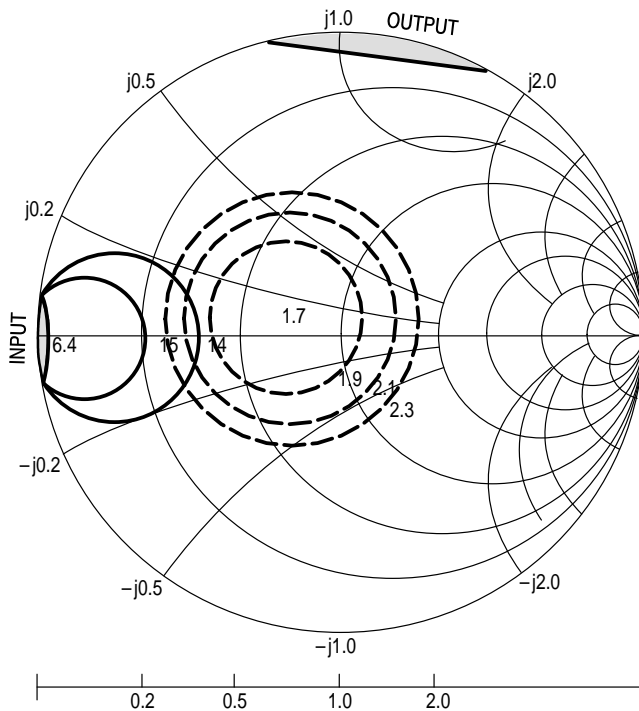

V _{CE} (Vdc)	I _C (mA)	f (MHz)	S ₁₁		S ₂₁		S ₁₂		S ₂₂	
			S ₁₁	∠	S ₂₁	∠	S ₁₂	∠	S ₂₂	∠
6.0	5.0	200	0.79	-90	10.9	128	0.06	46	0.70	-45
		500	0.72	-144	5.7	96	0.08	28	0.42	-66
		1000	0.69	-177	3.0	75	0.09	28	0.31	-77
		1500	0.66	164	2.0	59	0.10	32	0.34	-89
		2000	0.65	147	1.6	47	0.12	38	0.32	-94
	10	200	0.72	-115	15.2	118	0.05	41	0.55	-66
		500	0.69	-160	6.9	92	0.06	34	0.30	-92
		1000	0.67	174	3.6	74	0.08	42	0.21	-108
		1500	0.64	159	2.4	60	0.10	46	0.23	-114
		2000	0.64	143	1.8	49	0.12	50	0.20	-116
	50	200	0.67	-159	20	102	0.02	48	0.33	-111
		500	0.67	179	8.2	85	0.04	58	0.33	-142
		1000	0.66	174	3.8	72	0.07	65	0.21	-158
		1500	0.63	151	2.7	61	0.10	64	0.22	-158
		2000	0.58	138	2.1	51	0.14	62	0.17	-165
8.0	5.0	200	0.80	-87	11.1	130	0.06	47	0.71	-42
		500	0.72	-141	5.9	97	0.08	30	0.44	-60
		1000	0.70	-177	3.1	75	0.09	28	0.33	-68
		1500	0.66	166	2.1	60	0.10	32	0.35	-80
		2000	0.61	149	1.6	47	0.12	39	0.35	-85
	10	200	0.72	-113	15.6	119	0.05	42	0.56	-61
		500	0.68	-159	7.2	92	0.06	34	0.31	-82
		1000	0.66	175	3.7	74	0.08	41	0.21	-92
		1500	0.64	160	2.5	61	0.09	47	0.23	-101
		2000	0.60	144	2.0	49	0.13	50	0.21	-103
	50	200	0.66	-156	20.9	103	0.02	48	0.31	-101
		500	0.65	-179	8.6	85	0.04	58	0.19	-128
		1000	0.64	164	4.3	72	0.07	65	0.16	-144
		1500	0.61	153	2.9	61	0.10	65	0.17	-142
		2000	0.58	137	2.3	51	0.13	64	0.14	-145

Table 2. MRF5711LT1 Common Emitter S-Parameters

PACKAGE DIMENSIONS

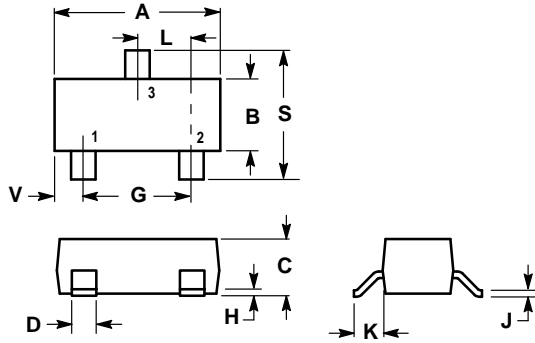

NOTES:

1. DIMENSIONING AND TOLERANCING PER ANSI Y14.5M, 1982.
2. CONTROLLING DIMENSION: INCH.
3. MAXIMUM LEAD THICKNESS INCLUDES LEAD FINISH THICKNESS. MINIMUM LEAD THICKNESS IS THE MINIMUM THICKNESS OF BASE MATERIAL.

DIM	INCHES		MILLIMETERS	
	MIN	MAX	MIN	MAX
A	0.1102	0.1197	2.80	3.04
B	0.0472	0.0551	1.20	1.40
C	0.0350	0.0440	0.89	1.11
D	0.0150	0.0200	0.37	0.50
G	0.0701	0.0807	1.78	2.04
H	0.0005	0.0040	0.013	0.100
J	0.0034	0.0070	0.085	0.177
K	0.0140	0.0285	0.35	0.69
L	0.0350	0.0401	0.89	1.02
S	0.0830	0.1039	2.10	2.64
V	0.0177	0.0236	0.45	0.60

STYLE 6:

- PIN 1. BASE
2. EMITTER
3. COLLECTOR

**CASE 318-08
ISSUE AF
MMBR571LT1**

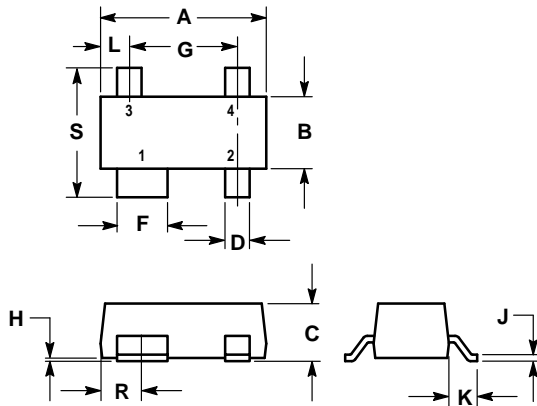

NOTES:

4. DIMENSIONING AND TOLERANCING PER ANSI Y14.5M, 1982.
5. CONTROLLING DIMENSION: MILLIMETER.

DIM	MILLIMETERS		INCHES	
	MIN	MAX	MIN	MAX
A	2.80	3.04	0.110	0.120
B	1.20	1.39	0.047	0.055
C	0.84	1.14	0.033	0.045
D	0.39	0.50	0.015	0.020
F	0.79	0.93	0.031	0.037
G	1.78	2.03	0.070	0.080
H	0.013	0.10	0.0005	0.004
J	0.08	0.15	0.003	0.006
K	0.46	0.60	0.018	0.024
L	0.445	0.60	0.0175	0.024
R	0.72	0.83	0.028	0.033
S	2.11	2.48	0.083	0.098

STYLE 1:

- PIN 1. COLLECTOR
2. EMITTER
3. EMITTER
4. BASE

**CASE 318A-05
ISSUE R
MRF5711LT1**

Motorola reserves the right to make changes without further notice to any products herein. Motorola makes no warranty, representation or guarantee regarding the suitability of its products for any particular purpose, nor does Motorola assume any liability arising out of the application or use of any product or circuit, and specifically disclaims any and all liability, including without limitation consequential or incidental damages. "Typical" parameters which may be provided in Motorola data sheets and/or specifications can and do vary in different applications and actual performance may vary over time. All operating parameters, including "Typicals" must be validated for each customer application by customer's technical experts. Motorola does not convey any license under its patent rights nor the rights of others. Motorola products are not designed, intended, or authorized for use as components in systems intended for surgical implant into the body, or other applications intended to support or sustain life, or for any other application in which the failure of the Motorola product could create a situation where personal injury or death may occur. Should Buyer purchase or use Motorola products for any such unintended or unauthorized application, Buyer shall indemnify and hold Motorola and its officers, employees, subsidiaries, affiliates, and distributors harmless against all claims, costs, damages, and expenses, and reasonable attorney fees arising out of, directly or indirectly, any claim of personal injury or death associated with such unintended or unauthorized use, even if such claim alleges that Motorola was negligent regarding the design or manufacture of the part. Motorola and  are registered trademarks of Motorola, Inc. Motorola, Inc. is an Equal Opportunity/Affirmative Action Employer.

Mfax is a trademark of Motorola, Inc.

How to reach us:

USA/EUROPE/Locations Not Listed: Motorola Literature Distribution;
P.O. Box 5405, Denver, Colorado 80217. 1-303-675-2140 or 1-800-441-2447

JAPAN: Motorola Japan Ltd.; SPD, Strategic Planning Office, 141,
4-32-1 Nishi-Gotanda, Shinagawa-ku, Tokyo, Japan. 81-3-5487-8488

Customer Focus Center: 1-800-521-6274

Mfax™: RMFAX0@email.sps.mot.com – TOUCHTONE 1-602-244-6609
Motorola Fax Back System – US & Canada ONLY 1-800-774-1848
– http://sps.motorola.com/mfax/

ASIA/PACIFIC: Motorola Semiconductors H.K. Ltd.; 8B Tai Ping Industrial Park,
51 Ting Kok Road, Tai Po, N.T., Hong Kong. 852-26629298

HOME PAGE: <http://motorola.com/sps/>



MOTOROLA



MMBR571LT1/D