

# Dual D-Type Flip-Flop with Preset and Clear

## MM74HC74A

The MM74HC74A utilizes advanced silicon-gate CMOS technology to achieve operating speeds similar to the equivalent LS-TTL part. It possesses the high noise immunity and low power consumption of standard CMOS integrated circuits, along with the ability to drive 10 LS-TTL loads.

This flip-flop has independent data, preset, clear, and clock inputs and Q and  $\bar{Q}$  outputs. The logic level present at the data input is transferred to the output during the positive-going transition of the clock pulse. Preset and clear are independent of the clock and accomplished by a low level at the appropriate input.

The 74HC logic family is functionally and pinout compatible with the standard 74LS logic family. All inputs are protected from damage due to static discharge by internal diode clamps to  $V_{CC}$  and ground.

### Features

- Typical Propagation Delay: 12 ns
- Wide Power Supply Range: 2 V – 6 V
- Low Quiescent Current: 80  $\mu$ A maximum (74HC Series)
- Low Input Current: 1  $\mu$ A Maximum
- Fanout of 10 LS-TTL Loads
- These Devices are Pb-Free, Halide Free and are RoHS Compliant

### Connection Diagram

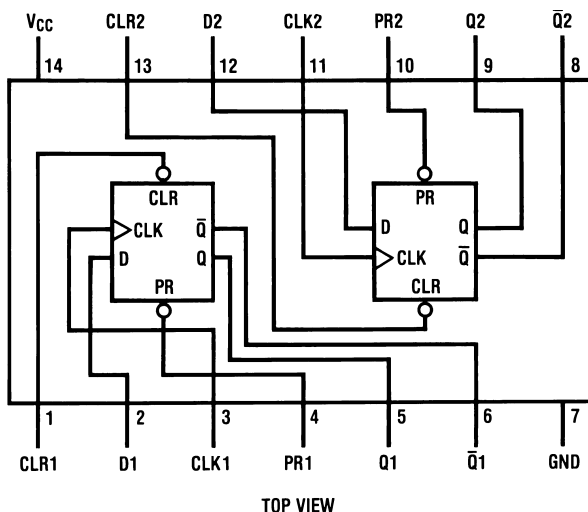
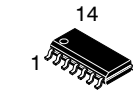
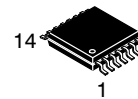

Figure 1. Pin Assignments for SOIC and TSSOP



SOIC-14  
CASE 751EF



TSSOP-14 WB  
CASE 948G

### MARKING DIAGRAM

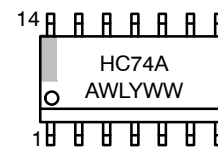

SOIC-14 NB

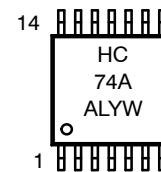

TSSOP-14 WB

HC74A = Specific Device Code  
A = Assembly Location  
WL, L = Wafer Lot  
Y = Year  
WW, W = Work Week

### TRUTH TABLE

Inputs				Outputs	
PR	CLR	CLK	D	Q	$\bar{Q}$
L	H	X	X	H	L
H	L	X	X	L	H
L	L	X	X	H	H
				(Note1)	(Note1)
H	H	↑	H	H	L
H	H	↑	L	L	H
H	H	L	X	Q <sub>0</sub>	$\bar{Q}$ <sub>0</sub>

Q<sub>0</sub> = the level of Q before the indicated input conditions were established.

1. This configuration is nonstable; that is, it will not persist when preset and clear inputs return to their inactive (HIGH) level.

### ORDERING INFORMATION

See detailed ordering and shipping information on page 5 of this data sheet.

# MM74HC74A

## Logic Diagram

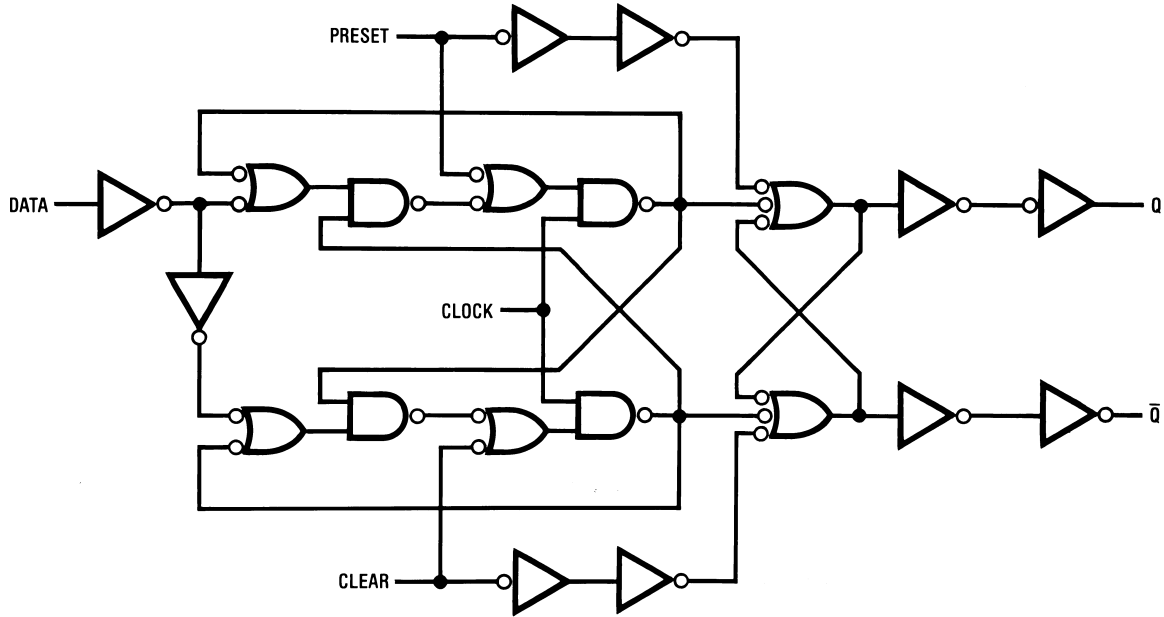

Figure 2. Logic Diagram

### MAXIMUM RATINGS (Note 2)

Symbol	Parameter		Rating
$V_{CC}$	Supply Voltage		-0.5 to +7.0 V
$V_{IN}$	DC Input Voltage		-0.5 to $V_{CC} + 0.5$ V
$V_{OUT}$	DC Output Voltage		-0.5 to $V_{CC} + 0.5$ V
$I_{IK}, I_{OK}$	Clamp Diode Current		$\pm 20$ mA
$I_{OUT}$	DC Output Current, per Pin		$\pm 25$ mA
$I_{CC}$	DC $V_{CC}$ or GND Current, per Pin		$\pm 50$ mA
$T_{STG}$	Storage Temperature Range		-65°C to +150°C
$P_D$	Power Dissipation	(Note 3)	600 mW
		S.O. Package Only	500 mW
$T_L$	Lead Temperature (Soldering 10 Seconds)		260°C

Stresses exceeding those listed in the Maximum Ratings table may damage the device. If any of these limits are exceeded, device functionality should not be assumed, damage may occur and reliability may be affected.

2. Unless otherwise specified all voltages are referenced to ground.

3. Power Dissipation temperature derating – plastic “N” package: -12 mW/°C from 65°C to 85°C.

### RECOMMENDED OPERATING CONDITIONS

Symbol	Parameter		Min	Max	Unit
$V_{CC}$	Supply Voltage		2	6	V
$V_{IN}, V_{OUT}$	DC Input or Output Voltage		0	$V_{CC}$	V
$T_A$	Operating Temperature Range		-55	+125	°C
$t_r, t_f$	Input Rise or Fall Times	$V_{CC} = 2.0$ V	-	1000	ns
		$V_{CC} = 4.5$ V	-	500	ns
		$V_{CC} = 6.0$ V	-	400	ns

Functional operation above the stresses listed in the Recommended Operating Ranges is not implied. Extended exposure to stresses beyond the Recommended Operating Ranges limits may affect device reliability.

# MM74HC74A

## DC CHARACTERISTICS (Note 4)

Symbol	Parameter	V <sub>CC</sub> (V)	Conditions	T <sub>A</sub> = 25°C		T <sub>A</sub> = -40°C	T <sub>A</sub> = -55°C	Unit
				Typ	Guaranteed Limits			
V <sub>IH</sub>	Minimum HIGH Level Input Voltage	2.0		-	1.5	1.5	1.5	V
		4.5		-	3.15	3.15	3.15	
		6.0		-	4.2	4.2	4.2	
V <sub>IL</sub>	Maximum LOW Level Input Voltage	2.0		-	0.5	0.5	0.5	V
		4.5		-	1.35	1.35	1.35	
		6.0		-	1.8	1.8	1.8	
V <sub>OH</sub>	Minimum HIGH Level Output Voltage	2.0	V <sub>IN</sub> = V <sub>IH</sub> or V <sub>IL</sub> ,  I <sub>OUT</sub>   ≤ 20 μA	2.0	1.9	1.9	1.9	V
		4.5		4.5	4.4	4.4	4.4	
		6.0	6.0	5.9	5.9	5.9		
		4.5	V <sub>IN</sub> = V <sub>IH</sub> or V <sub>IL</sub> ,  I <sub>OUT</sub>   ≤ 4.0 mA	4.3	3.98	3.84	3.7	
V <sub>OL</sub>	Maximum LOW Level Output Voltage	2.0	V <sub>IN</sub> = V <sub>IH</sub> or V <sub>IL</sub> ,  I <sub>OUT</sub>   ≤ 20 μA	0	0.1	0.1	0.1	V
		4.5		0	0.1	0.1	0.1	
		6.0	0	0.1	0.1	0.1		
		4.5	V <sub>IN</sub> = V <sub>IH</sub> or V <sub>IL</sub> ,  I <sub>OUT</sub>   ≤ 4.0 mA	0.2	0.26	0.33	0.4	
6.0	V <sub>IN</sub> = V <sub>IH</sub> or V <sub>IL</sub> ,  I <sub>OUT</sub>   ≤ 5.2 mA	0.2	0.26	0.33	0.4			
	I <sub>IN</sub>	Maximum Input Current	6.0	V <sub>IN</sub> = V <sub>CC</sub> or GND	-	±0.1	±1.0	±1.0
I <sub>CC</sub>	Maximum Quiescent Supply Current	6.0	V <sub>IN</sub> = V <sub>CC</sub> or GND, I <sub>OUT</sub> = 0 μA	-	4.0	40	80	μA

4. For a power supply of 5 V ±10% the worst case output voltages (V<sub>OH</sub>, and V<sub>OL</sub>) occur for HC at 4.5 V. Thus the 4.5 V values should be used when designing with this supply. Worst case V<sub>IH</sub> and V<sub>IL</sub> occur at V<sub>CC</sub> = 5.5 V and 4.5 V respectively. (The V<sub>IH</sub> value at 5.5 V is 3.85 V.) The worst case leakage current (I<sub>IN</sub>, I<sub>CC</sub>, and I<sub>OZ</sub>) occur for CMOS at the higher voltage and so the 6.0 V values should be used.

## AC CHARACTERISTICS (V<sub>CC</sub> = 5 V, T<sub>A</sub> = 25°C, C<sub>L</sub> = 15 pF, t<sub>r</sub> = t<sub>f</sub> = 6 ns)

Symbol	Parameter	Conditions	Typ	Guaranteed Limit	Unit
f <sub>MAX</sub>	Maximum Operating Frequency		72	30	MHz
t <sub>PHL</sub> , t <sub>PLH</sub>	Maximum Propagation Delay, Clock to Q or $\bar{Q}$		10	30	ns
t <sub>PHL</sub> , t <sub>PLH</sub>	Maximum Propagation Delay, Preset or Clear to Q or $\bar{Q}$		17	40	ns
t <sub>REM</sub>	Minimum Removal Time, Preset or Clear to Clock		6	5	ns
t <sub>s</sub>	Minimum Setup Time, Data to Clock		10	20	ns
t <sub>H</sub>	Minimum Hold Time, Clock to Data		0	0	ns
t <sub>w</sub>	Minimum Pulse Width Clock, Preset or Clear		8	16	ns

# MM74HC74A

## AC CHARACTERISTICS (C<sub>L</sub> = 50 pF, t<sub>r</sub> = t<sub>f</sub> = 6 ns (unless otherwise specified))

Symbol	Parameter	V <sub>CC</sub> (V)	Conditions	T <sub>A</sub> = 25°C		T <sub>A</sub> = -40°C	T <sub>A</sub> = -55°C	Unit
				Typ	Guaranteed Limits			
f <sub>MAX</sub>	Maximum Operating Frequency	2.0		22	6	5	4	ns
		4.5		72	30	24	20	
		6.0		94	35	28	24	
t <sub>PHL</sub> , t <sub>PLH</sub>	Maximum Propagation Delay, Clock to Q or $\bar{Q}$	2.0		34	110	140	165	ns
		4.5		12	22	28	33	
		6.0		10	19	24	28	
t <sub>PHL</sub> , t <sub>PLH</sub>	Maximum Propagation Delay, Preset or Clear to Q or $\bar{Q}$	2.0		66	150	190	225	ns
		4.5		20	30	38	45	
		6.0		16	26	33	38	
t <sub>REM</sub>	Minimum Removal Time, Preset or Clear to Clock	2.0		20	50	65	75	ns
		4.5		6	10	13	15	
		6.0		5	9	11	13	
t <sub>s</sub>	Minimum Setup Time, Data to Clock	2.0		35	80	100	120	ns
		4.5		10	16	20	24	
		6.0		8	14	17	20	
t <sub>H</sub>	Minimum Hold Time, Clock to Data	2.0		-	0	0	0	ns
		4.5		-	0	0	0	
		6.0		-	0	0	0	
t <sub>w</sub>	Minimum Pulse Width Clock, Preset or Clear	2.0		30	80	101	119	ns
		4.5		9	16	20	24	
		6.0		8	14	17	20	
t <sub>TLH</sub> , t <sub>THL</sub>	Maximum Output Rise and Fall Time	2.0		25	75	95	110	ns
		4.5		7	15	19	22	
		6.0		6	13	16	19	
t <sub>r</sub> , t <sub>f</sub>	Maximum Input Rise and Fall Time	2.0		-	1000	1000	1000	ns
		4.5		-	500	500	500	
		6.0		-	400	400	400	
C <sub>PD</sub>	Power Dissipation Capacitance (Note 5)		(per flip-flop)	80	-	-	-	pF
C <sub>IN</sub>	Maximum Input Capacitance			5	10	10	10	pF

5. C<sub>PD</sub> determines the no load dynamic power consumption,  $P_D = C_{PD} V_{CC}^2 f + I_{CC} V_{CC}$ , and the no load dynamic current consumption,  $I_S = C_{PD} V_{CC} f + I_{CC}$ .

# MM74HC74A

## ORDERING INFORMATION

Part Number	Package	Shipping†
MM74HC74AM	SOIC-14, Case 751EF (Pb-Free, Halide Free)	55 Units / Tube
MM74HC74AMTC	TSSOP-14, Case 948G-01 (Pb-Free, Halide Free)	96 Units / Tube
MM74HC74AMX	SOIC-14, Case 751EF (Pb-Free, Halide Free)	2500 / Tape & Reel
MM74HC74AMTCX	TSSOP-14 WB, Case 948G-01 (Pb-Free, Halide Free)	2500 / Tape & Reel

†For information on tape and reel specifications, including part orientation and tape sizes, please refer to our Tape and Reel Packaging Specifications Brochure, BRD8011/D.

NOTE: Device also available in Tape and Reel. Specify by appending suffix letter "X" to the ordering number.

**MECHANICAL CASE OUTLINE**  
**PACKAGE DIMENSIONS**

ON Semiconductor®



**SOIC14**  
**CASE 751EF**  
**ISSUE O**

DATE 30 SEP 2016

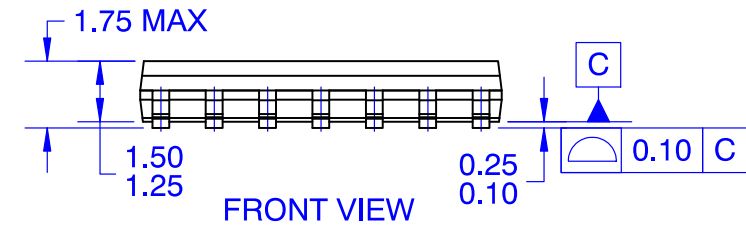
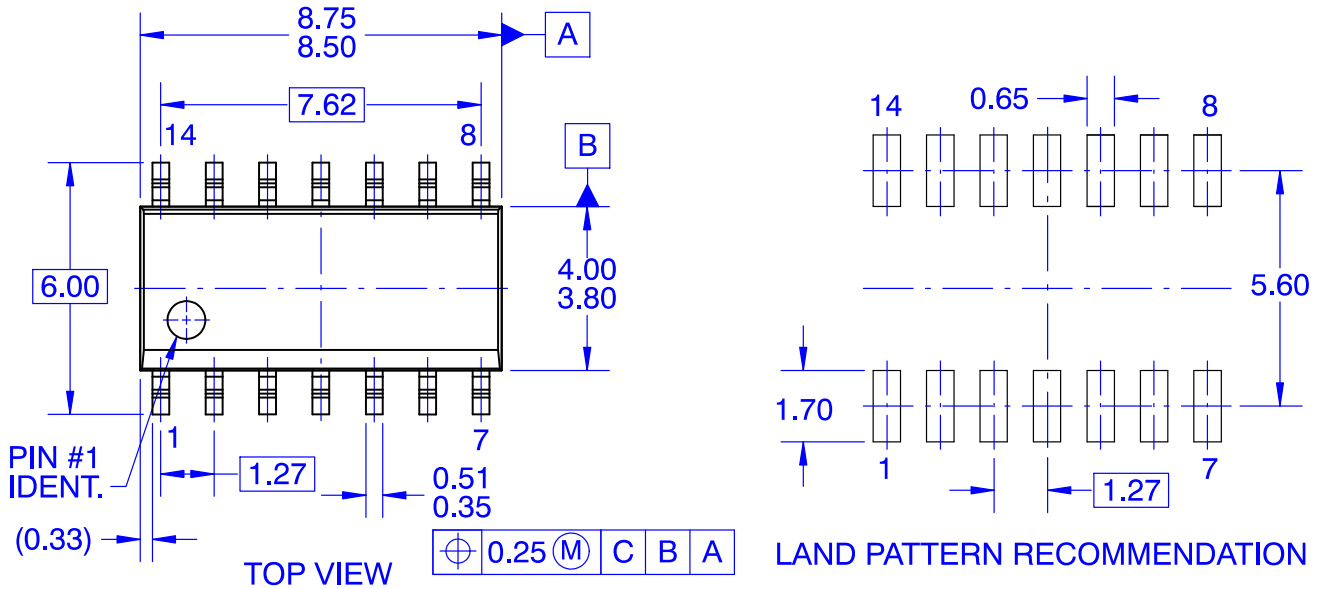

**NOTES:**

- A. CONFORMS TO JEDEC MS-012, VARIATION AB, ISSUE C
- B. ALL DIMENSIONS ARE IN MILLIMETERS
- C. DIMENSIONS DO NOT INCLUDE MOLD FLASH OR BURRS
- D. LAND PATTERN STANDARD: SOIC127P600X145-14M
- E. CONFORMS TO ASME Y14.5M, 2009

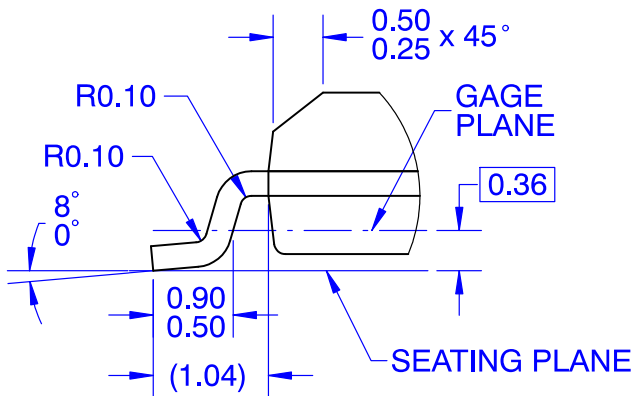

<b>DOCUMENT NUMBER:</b>	<b>98AON13739G</b>	Electronic versions are uncontrolled except when accessed directly from the Document Repository. Printed versions are uncontrolled except when stamped "CONTROLLED COPY" in red.
<b>DESCRIPTION:</b>	<b>SOIC14</b>	<b>PAGE 1 OF 1</b>

ON Semiconductor and are trademarks of Semiconductor Components Industries, LLC dba ON Semiconductor or its subsidiaries in the United States and/or other countries. ON Semiconductor reserves the right to make changes without further notice to any products herein. ON Semiconductor makes no warranty, representation or guarantee regarding the suitability of its products for any particular purpose, nor does ON Semiconductor assume any liability arising out of the application or use of any product or circuit, and specifically disclaims any and all liability, including without limitation special, consequential or incidental damages. ON Semiconductor does not convey any license under its patent rights nor the rights of others.

# MECHANICAL CASE OUTLINE PACKAGE DIMENSIONS

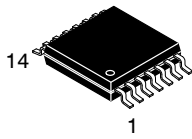

TSSOP-14 WB  
CASE 948G  
ISSUE C

DATE 17 FEB 2016

SCALE 2:1

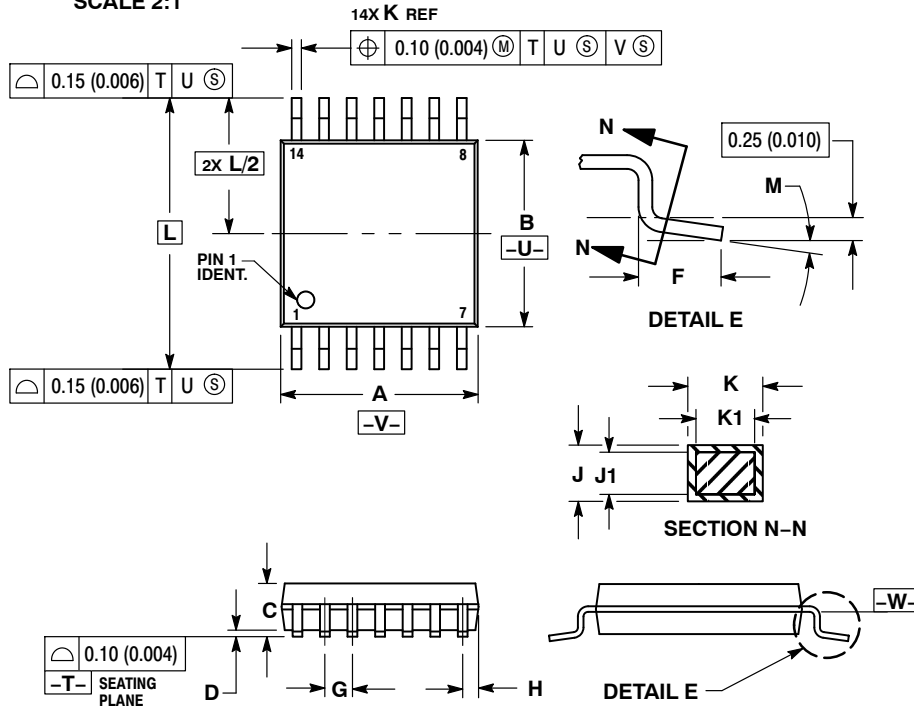

NOTES:

- DIMENSIONING AND TOLERANCING PER ANSI Y14.5M, 1982.
- CONTROLLING DIMENSION: MILLIMETER.
- DIMENSION A DOES NOT INCLUDE MOLD FLASH, PROTRUSIONS OR GATE BURRS. MOLD FLASH OR GATE BURRS SHALL NOT EXCEED 0.15 (0.006) PER SIDE.
- DIMENSION B DOES NOT INCLUDE INTERLEAD FLASH OR PROTRUSION. INTERLEAD FLASH OR PROTRUSION SHALL NOT EXCEED 0.25 (0.010) PER SIDE.
- DIMENSION K DOES NOT INCLUDE DAMBAR PROTRUSION. ALLOWABLE DAMBAR PROTRUSION SHALL BE 0.08 (0.003) TOTAL IN EXCESS OF THE K DIMENSION AT MAXIMUM MATERIAL CONDITION.
- TERMINAL NUMBERS ARE SHOWN FOR REFERENCE ONLY.
- DIMENSION A AND B ARE TO BE DETERMINED AT DATUM PLANE -W-.

DIM	MILLIMETERS		INCHES	
	MIN	MAX	MIN	MAX
A	4.90	5.10	0.193	0.200
B	4.30	4.50	0.169	0.177
C	---	1.20	---	0.047
D	0.05	0.15	0.002	0.006
F	0.50	0.75	0.020	0.030
G	0.65 BSC		0.026 BSC	
H	0.50	0.60	0.020	0.024
J	0.09	0.20	0.004	0.008
J1	0.09	0.16	0.004	0.006
K	0.19	0.30	0.007	0.012
K1	0.19	0.25	0.007	0.010
L	6.40 BSC		0.252 BSC	
M	0°	8°	0°	8°

### GENERIC MARKING DIAGRAM\*

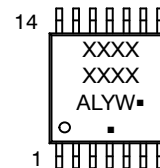

- A = Assembly Location
- L = Wafer Lot
- Y = Year
- W = Work Week
- = Pb-Free Package

(Note: Microdot may be in either location)

\*This information is generic. Please refer to device data sheet for actual part marking. Pb-Free indicator, "G" or microdot "▪", may or may not be present. Some products may not follow the Generic Marking.

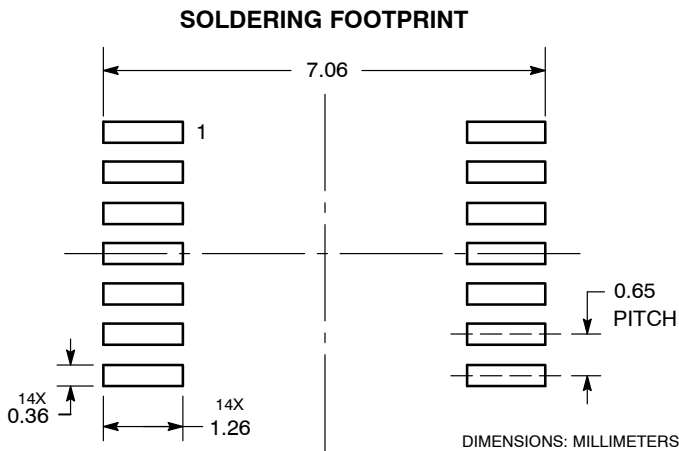

DOCUMENT NUMBER:	98ASH70246A	Electronic versions are uncontrolled except when accessed directly from the Document Repository. Printed versions are uncontrolled except when stamped "CONTROLLED COPY" in red.
DESCRIPTION:	TSSOP-14 WB	PAGE 1 OF 1

onsemi and onsemi are trademarks of Semiconductor Components Industries, LLC dba onsemi or its subsidiaries in the United States and/or other countries. onsemi reserves the right to make changes without further notice to any products herein. onsemi makes no warranty, representation or guarantee regarding the suitability of its products for any particular purpose, nor does onsemi assume any liability arising out of the application or use of any product or circuit, and specifically disclaims any and all liability, including without limitation special, consequential or incidental damages. onsemi does not convey any license under its patent rights nor the rights of others.

**onsemi**, **Onsemi**, and other names, marks, and brands are registered and/or common law trademarks of Semiconductor Components Industries, LLC dba "**onsemi**" or its affiliates and/or subsidiaries in the United States and/or other countries. **onsemi** owns the rights to a number of patents, trademarks, copyrights, trade secrets, and other intellectual property. A listing of **onsemi**'s product/patent coverage may be accessed at [www.onsemi.com/site/pdf/Patent-Marking.pdf](http://www.onsemi.com/site/pdf/Patent-Marking.pdf). **onsemi** reserves the right to make changes at any time to any products or information herein, without notice. The information herein is provided "as-is" and **onsemi** makes no warranty, representation or guarantee regarding the accuracy of the information, product features, availability, functionality, or suitability of its products for any particular purpose, nor does **onsemi** assume any liability arising out of the application or use of any product or circuit, and specifically disclaims any and all liability, including without limitation special, consequential or incidental damages. Buyer is responsible for its products and applications using **onsemi** products, including compliance with all laws, regulations and safety requirements or standards, regardless of any support or applications information provided by **onsemi**. "Typical" parameters which may be provided in **onsemi** data sheets and/or specifications can and do vary in different applications and actual performance may vary over time. All operating parameters, including "Typicals" must be validated for each customer application by customer's technical experts. **onsemi** does not convey any license under any of its intellectual property rights nor the rights of others. **onsemi** products are not designed, intended, or authorized for use as a critical component in life support systems or any FDA Class 3 medical devices or medical devices with a same or similar classification in a foreign jurisdiction or any devices intended for implantation in the human body. Should Buyer purchase or use **onsemi** products for any such unintended or unauthorized application, Buyer shall indemnify and hold **onsemi** and its officers, employees, subsidiaries, affiliates, and distributors harmless against all claims, costs, damages, and expenses, and reasonable attorney fees arising out of, directly or indirectly, any claim of personal injury or death associated with such unintended or unauthorized use, even if such claim alleges that **onsemi** was negligent regarding the design or manufacture of the part. **onsemi** is an Equal Opportunity/Affirmative Action Employer. This literature is subject to all applicable copyright laws and is not for resale in any manner.

## PUBLICATION ORDERING INFORMATION

### LITERATURE FULFILLMENT:

Email Requests to: [orderlit@onsemi.com](mailto:orderlit@onsemi.com)

**onsemi Website:** [www.onsemi.com](http://www.onsemi.com)

### TECHNICAL SUPPORT

**North American Technical Support:**

Voice Mail: 1 800-282-9855 Toll Free USA/Canada

Phone: 011 421 33 790 2910

**Europe, Middle East and Africa Technical Support:**

Phone: 00421 33 790 2910

For additional information, please contact your local Sales Representative