

Features and Benefits

- Triaxis™ Hall Technology
- Sensitive to a magnetic field parallel to the chip surface
- Very high sensitivity
- Linear output voltage proportional to a magnetic field
- Wideband: DC to 100kHz
- Short response time 8μs
- Low offset and offset drift
- Very low noise
- Isolated from current conductor
- Surface mount SOIC8 package

Applications Examples

- AC and/or DC contactless current measurement
- Wideband Magnetic Field Measurement
- Battery Management
- AC/DC Converters
- Motor Control
- Solar Power Converter (MPPT)
- Power Management

Ordering Information

Part No.	Temperature Code	Package Code	Option code
MLX91205KDC-LB	(-40 °C to 125 °C)	DC (SOIC)	
MLX91205KDC-HB	(-40 °C to 125 °C)	DC (SOIC)	

1 Functional diagram

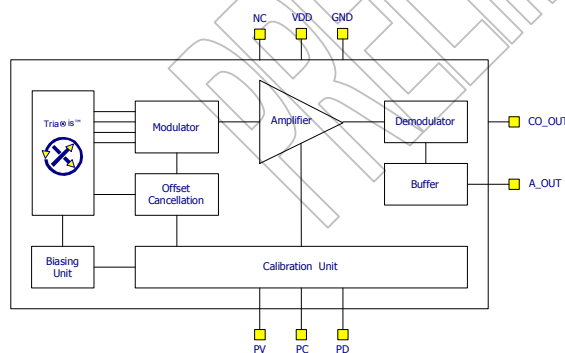

2 General description

The new Triaxis™ current sensor MLX91205 is a single axis integrated magnetic sensor based on the Hall Effect. It produces an analog linear, ratio-metric output voltage proportional to the applied magnetic field parallel with the chip surface.

The circuit is fabricated using a standard CMOS process. The additional ferromagnetic layer (Triaxis™ or IMC™ = Integrated Magnetic Concentrator) that is added in a simple post-processing step, amplifies the magnetic field and concentrates it on the Hall elements. Therefore, the circuit features very high magnetic sensitivity, low offset, and low noise.

The MLX91205 is ideally suited for current sensing in automotive and industrial environments.

There are 2 different product versions available. The 91205HB features a linear magnetic field range of ±25mT and the 91205LB features a linear range of ±10mT.

HB refers to a high magnetic field, whereas LB refers to a low magnetic field range.

Table of Contents

1 Functional diagram	1
2 General description	1
3 Glossary of Terms	3
4 Maximum ratings	3
5 Pin definitions and descriptions	3
6 MLX91205 General Electrical Specifications	4
MLX91205 Sensor Specific Specifications	4
7	4
7.1 91205 LB: Low Field version 10mT (marking xxL)	4
7.2 91205HB: High Field version 25mT (marking xxH)	5
8 Detailed General Description	6
9 Unique Features	6
10 Performance Graphs	7
10.1 Offset over Temperature	7
10.2 Sensitivity over Temperature	7
11 Applications Information	8
11.1 Low current measurement up to ± 2 A	8
11.2 Medium current up to ± 30 A	8
11.3 High current measurement up to ± 600 A	8
11.4 Customer Calibration with MCU	8
12 Application Diagram	9
12.1 Direct Single Ended Output	9
12.2 Direct Differential Output	9
13 Standard information regarding manufacturability of Melexis products with different soldering processes	10
14 ESD Precautions	11
15 Package Information	11
15.1 Package Dimensions	11
15.2 Pinout and marking	12
15.3 Hall plate positioning	12
16 Disclaimer	13

3 Glossary of Terms

Gauss (G), Tesla (T): Magnetic flux density units where 1 mT = 10 G.

ADC: Analog-to-Digital Converter

TC: Sensitivity Temperature Coefficient (in ppm/Deg.C.).

Tria@is™ : The Tria@is™ technology refers to the Melexis Hall technology that is based on both planar and vertical (bulk & IMC) Hall plates. This technology allows the realization of Hall effect sensors able to sense the flux density along the 3 axis (i.e. X, Y & Z) as well as position sensors able to sense the magnetic vector over 360 degrees.

IMC: Integrated Magneto Concentrator. It concentrates the magnetic flux lines and bends them at the extremity under the planar Hall plate. Furthermore, it can provide some magnetic gain factor.

4 Maximum ratings

Parameter	Units
Supply Voltage, V _{DD} (overvoltage)	6V
Supply Voltage, V _{DD} (operating)	5.5V
Reverse Voltage Protection	0V
Operating Temperature Range, T _A	-40 to +125°C
Storage Temperature Range, T _S	-40 to +150°C

Table 1: Absolute maximum ratings

Exceeding the absolute maximum ratings may cause permanent damage. Exposure to absolute maximum rated conditions for extended periods may affect device reliability.

5 Pin definitions and descriptions

Pin Number	Pin Name	Function
1	A_out	Analog Output
2	VDD	Supply
3	NC	
4	PV	Factory Programming Pin (default VDD)
5	GND	Supply Common
6	PD	Factory Programming Pin (default GND)
7	PC	Factory Programming Pin (default VDD)
8	CO_out	Common Output (VDD/2)

Table 2: Pin description MLX91205

Pin 1

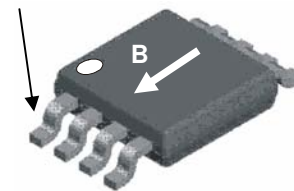

Magnetic sensitive direction

6 MLX91205 General Electrical Specifications

DC Operating Parameters $T_A = -40^{\circ}\text{C}$ to $+125^{\circ}\text{C}$, $V_{DD} = 5.000\text{V}$ (unless otherwise specified)

Parameter	Symbol	Test Conditions	Min	Typ	Max	Units
Nominal Supply Voltage	Vdd		4.5	5	5.5	V
Supply Current	Idd	Iout=0mA		11	16	mA
Common Output	CO_Out	Referring to VDD/2	-50	VDD/2	+50	mV
Output Current	Iout		-1		1	mA
Output Load Resistance	Rload		5			kΩ
Output Load Capacitance	Cload			1000		pF
Start-up cycle	Ts			150		μs

Table 3: Electrical specifications

7 MLX91205 Sensor Specific Specifications

7.1 91205 LB: Low Field version 10mT (marking xxL)

DC Operating Parameters $T_A = -40^{\circ}\text{C}$ to 125°C , $V_{DD} = 5.000\text{V}$, differential output (i.e. $V_{out} = A_{out} - CO_{out}$), unloaded. Unless otherwise specified.

Parameter.	Symbol	Test Conditions	Min	Typ	Max	Units
Magnetic Sensitivity	$S^{(1)}$	$T=25^{\circ}\text{C}$, $B = B_L$	275	280	285	V/T
Magnetic Sensitivity over Temp.	$S_T^{(1)}$	$T = -40, 25, 125^{\circ}\text{C}$; See also below 10.2	270	280	290	V/T
Thermal Sensitivity Drift	TC	$T = 25^{\circ}\text{C}$		<+/-200		ppm/°C
Offset Voltage	Voff	$T = 25^{\circ}\text{C}$	-20	0	20	mV
Offset Voltage over Temperature	VoffT	$T = -40, 25, 125^{\circ}\text{C}$; See also below 10.1	-50	0	50	mV
Linear Magnetic Field Range	B_L		-7.5		7.5	mV
Fullscale Magnetic Field Range	B_{FS}			±10		mT
Non Linearity	NL	$B < B_L$		±0.5		%
Hysteresis	Hyst	$B < 100\text{mT}$		<±10		μT
Max. Output Voltage Swing	Vout,max	$B > B_{FS}$	5		95	%VDD
Response Time	tr			8		μs
Bandwidth (-3 dB) DC to	BW	$R_{Load} > 1\text{M}\Omega$; $C_{Load} < 10\text{pF}$		100		kHz
Spectral Noise Density	ΔBnoise	f=10Hz to 10kHz		<125		nT/sqrt(Hz)

Table 4: Sensor specifications 10mT version (low-field version)

Note 1: Ratiometric (proportional to Vdd). The absolute accuracy on magnetic sensitivity trimming is +/- 2%.

7.2 91205HB: High Field version 25mT (marking xxH)

DC Operating Parameters $T_A = -40^{\circ}\text{C}$ to 125°C , $V_{DD} = 5.000\text{V}$, differential output (i.e. $V_{out} = A_{out} - CO_{out}$), unloaded. Unless otherwise specified.

Parameter.	Symbol	Test Conditions	Min	Typ	Max	Units
Magnetic Sensitivity	$S^{(1)}$	$T=25^{\circ}\text{C}$, $B = B_L$	97.5	100	102.5	V/T
Magnetic Sensitivity over Temp.	$S_T^{(1)}$	$T = -40, 25, 125^{\circ}\text{C}$; See also below 10.2	95	100	105	V/T
Thermal Sensitivity Drift	TC	$T = 25^{\circ}\text{C}$		<+/-200		ppm/ $^{\circ}\text{C}$
Offset Voltage	V_{off}	$T = 25^{\circ}\text{C}$	-20	0	20	mV
Offset Voltage over Temperature	V_{offT}	$T = -40, 25, 125^{\circ}\text{C}$; See also below 10.1	-50	0	50	mV
Linear Magnetic Field Range	B_L		-20		20	mV
Fullscale Magnetic Field Range	B_{FS}			-25.. 25		mT
Non Linearity	NL	$B < B_L$		± 0.5		
Hysteresis	Hyst	$B < 100\text{mT}$		< ± 20		μT
Max. Output Voltage Swing	$V_{out,max}$	$B > B_{FS}$	5		95	%VDD
Response Time	T_r			8		μs
Bandwidth (-3 dB) DC to	BW	$R_{Load} > 1\text{M}\Omega$; $C_{Load} < 10\text{pF}$		100		kHz
Spectral Noise Density	ΔB_{noise}	$f = 10\text{Hz}$ to 10kHz		<125		nT/sqrt(Hz)

Table 5: Sensor specifications 25mT version (high-field version)

Note 1: Ratiometric (proportional to Vdd). The absolute accuracy on magnetic sensitivity trimming is +/- 2%.

8 Detailed General Description

Melexis IMC current sensor MLX91205 is a single axis magnetic field sensor based on the Hall Effect. It is an integrated combination of a CMOS Hall circuit and a thin ferromagnetic concentrator. The CMOS circuit contains two pairs of Hall elements for its sensitivity direction parallel with the chip surface. The ferromagnetic concentrator amplifies the external magnetic field and concentrates it on the Hall elements.

The MLX91205 is ideally suited for current sensing in harsh automotive and industrial environments for both AC and DC currents. It produces an analog, linear, ratio-metric output voltage proportional to the applied magnetic field parallel with the chip surface.

The circuit is fabricated using a standard CMOS process and the ferromagnetic layer is added in a simple post-processing step. The monolithic device incorporates Hall elements, offset cancellation circuitry, current source, chopper stabilized amplification circuitry, parameter programming capability.

By dynamic offset cancellation any offset voltage caused by temperature variations, packaging stress or others is strongly reduced. As a result, the device has an extremely stable signal output, is immune to mechanical stress and is virtually immune to temperature cycling.

Therefore, the circuit features a wide application range and very high accuracy.

9 Unique Features

Different to other linear Hall sensors the MLX91205 measures the magnetic field parallel with the chip surface.

Therefore this sensor is ideally used as an open-loop current sensor for PCB mounting. It features small size application design and a simple construction for various current ranges.

Due to **short Response time** and **high Bandwidth** this sensor is suitable for high speed current measurement in a contactless, high current, high voltage setup.

10 Performance Graphs

10.1 Offset over Temperature

The product is calibrated at room temperature and tested at -40°C, 25°C and +125°C. The Offset performance 0V ±20mV at room temperature and is 0V ±50mV over the temperature range from -40 to 125°C. The typical temperature drift is $0\text{mV}/^\circ\text{C} \pm 0.3\text{mV}/^\circ\text{C}$

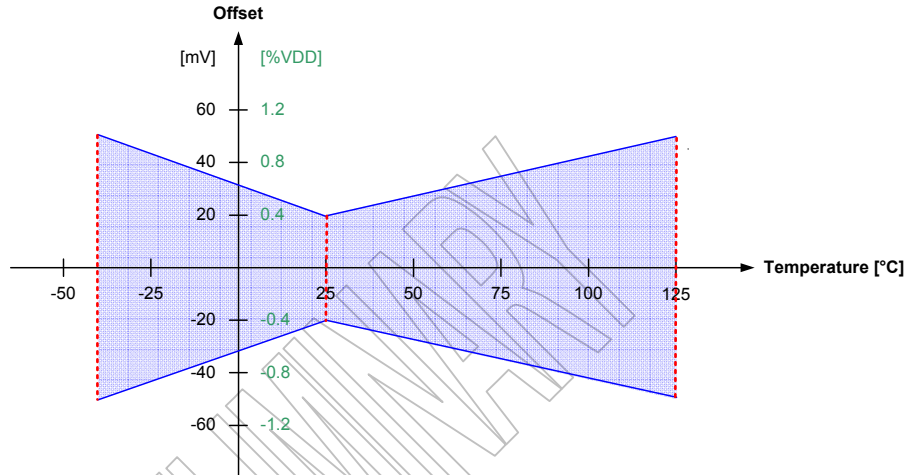

10.2 Sensitivity over Temperature

The product is calibrated at room temperature and tested at -40°C, 25°C and +125°C. The Sensitivity performance for the low field version is 280V/T ±5 V/T at room temperature and 280V/T ±10 V/T over the temperature range from -40 to 125°C. Typical temperature drift is <math>< 200\text{ppm}/^\circ\text{C}</math>.

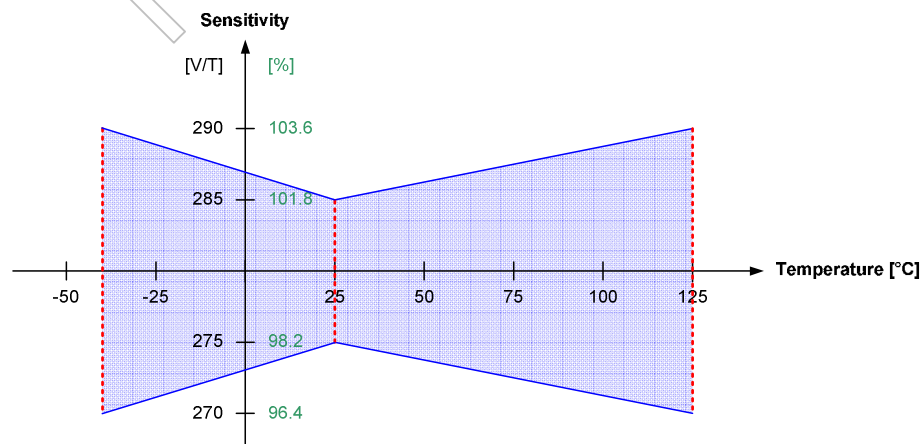

The corresponding sensitivity performance for the high field version is 100V/T ±2.5 V/T at room temperature and 100V/T ±5 V/T over the temperature range from -40 to 125°C.

11 Applications Information

11.1 Low current measurement up to ±2 A

Low currents can be measured with the MLX91205 by increasing the magnetic field via a coil around the sensor. The sensitivity (output voltage vs. current in coil) of the measurement will depend on the size of coil and number of turns. Additional sensitivity and increased immunity to external fields can be gained by adding a shield around the coil. The bobbin provides very high dielectric isolation making this a suitable solution for high voltage power supplies with relative low currents. The output should be scaled to obtain the maximum voltage for the highest current to be measured in order to obtain the best accuracy and resolution.

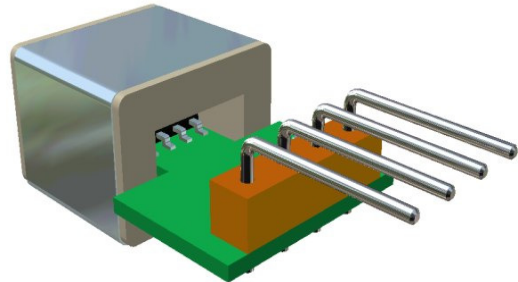

11.2 Medium current up to ±30 A

With a single conductor located on the PCB, currents in the range of up to 30 amps can be measured. The sizing of the PCB trace needs to take into account the current handling capability and the total power dissipation. The PCB trace needs to be thick enough and wide enough to handle the RMS current continuously.

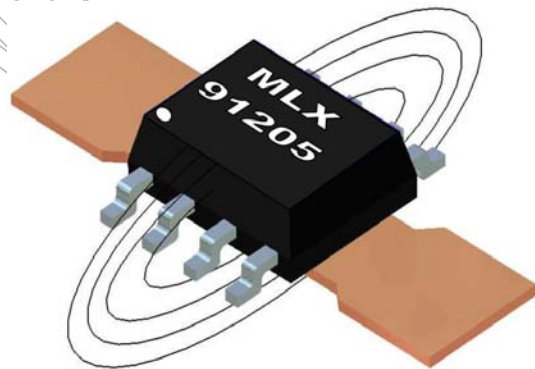

The differential output voltage for this configuration can be approximated by the following equation:

$$V_{out} = \text{typ. } 35 - 40 \text{ mV/A} \cdot I$$

For a current level of 30 A, the output will be approximately 1050 mV.

11.3 High current measurement up to ±600 A

Another method of measuring high currents on PCB's is to use a large thick gauge copper trace capable of carrying the current on the opposite side of the PCB. The MLX91205 should be located near the centre of the trace, however because the trace is wide, the output is less sensitive to location on the PCB. This configuration also has less sensitivity due to the distance and width of the conductor.



11.4 Customer Calibration with MCU

In many applications one measures the output voltage of the 91205 with a microcontroller. The current-sensor-system accuracy can be significantly increased by customer calibration of the system after assembling the 91205 in the application. By applying a known current i.e. 100 Amperes, one can calibrate by means of the microcontroller the output voltage to the exact value i.e. 2.000V at 100 Amperes. By doing so, the offset and sensitivity can be calibrated simply at a certain temperature.

12 Application Diagram

12.1 Direct Single Ended Output

For reliable operation within the specifications the sensor must be connected as follows:

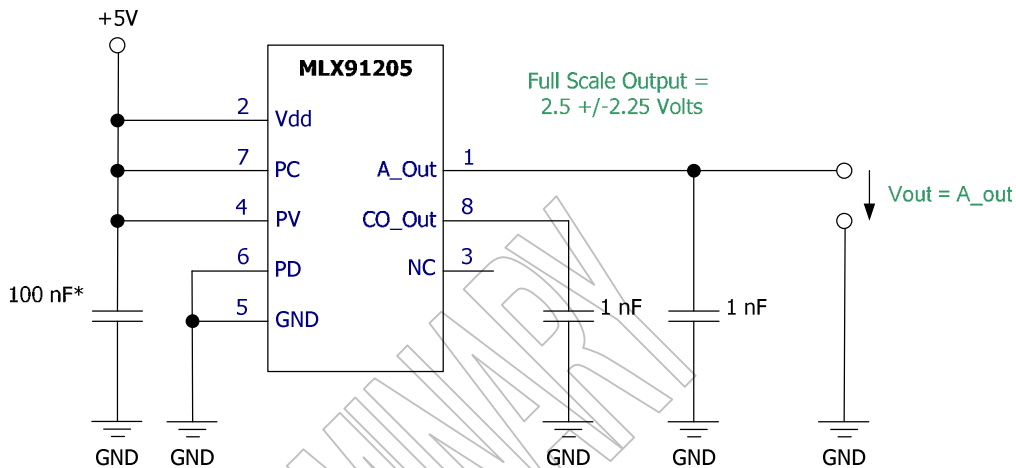

* if the supply voltage is disturbed by EMI it can be useful to place a second capacitor (100pF ceramic) parallel to the 100nF capacitor.

12.2 Direct Differential Output

For reliable operation within the specifications the sensor must be connected as follows:

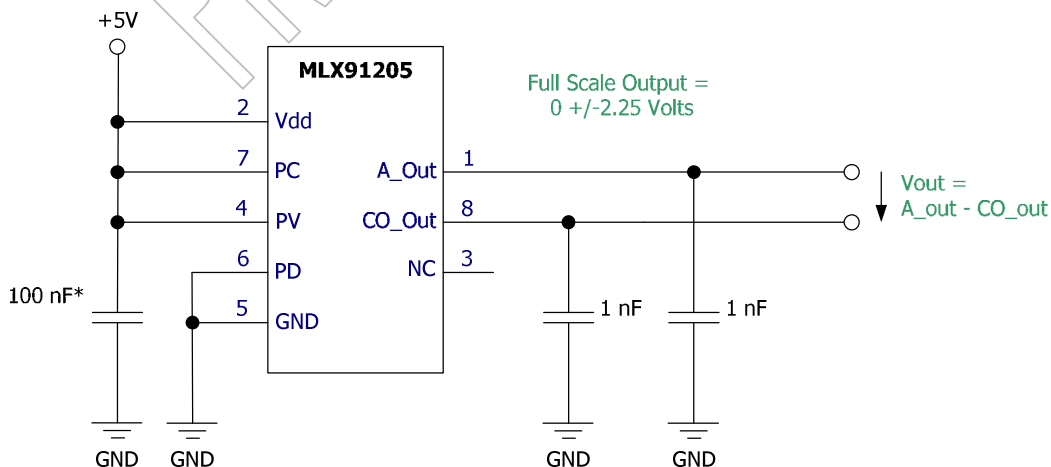

* if the supply voltage is disturbed by EMI it can be useful to place a second capacitor (100pF ceramic) parallel to the 100nF capacitor.

13 Standard information regarding manufacturability of Melexis products with different soldering processes

Our products are classified and qualified regarding soldering technology, solderability and moisture sensitivity level according to following test methods:

Reflow Soldering SMD's (Surface Mount Devices)

- IPC/JEDEC J-STD-020
Moisture/Reflow Sensitivity Classification for Nonhermetic Solid State Surface Mount Devices (classification reflow profiles according to table 5-2)
- EIA/JEDEC JESD22-A113
Preconditioning of Nonhermetic Surface Mount Devices Prior to Reliability Testing (reflow profiles according to table 2)

Wave Soldering SMD's (Surface Mount Devices) and THD's (Through Hole Devices)

- EN60749-20
Resistance of plastic- encapsulated SMD's to combined effect of moisture and soldering heat
- EIA/JEDEC JESD22-B106 and EN60749-15
Resistance to soldering temperature for through-hole mounted devices

Iron Soldering THD's (Through Hole Devices)

- EN60749-15
Resistance to soldering temperature for through-hole mounted devices

Solderability SMD's (Surface Mount Devices) and THD's (Through Hole Devices)

- EIA/JEDEC JESD22-B102 and EN60749-21
Solderability

For all soldering technologies deviating from above mentioned standard conditions (regarding peak temperature, temperature gradient, temperature profile etc) additional classification and qualification tests have to be agreed upon with Melexis.

The application of Wave Soldering for SMD's is allowed only after consulting Melexis regarding assurance of adhesive strength between device and board.

Melexis is contributing to global environmental conservation by promoting **lead free** solutions. For more information on qualifications of **RoHS** compliant products (RoHS = European directive on the Restriction Of the use of certain Hazardous Substances) please visit the quality page on our website:

<http://www.melexis.com/quality.asp>

14 ESD Precautions

Electronic semiconductor products are sensitive to Electro Static Discharge (ESD). Always observe Electro Static Discharge control procedures whenever handling semiconductor products. A well designed (capacitors close to pins and low resistive ground layout) PCB layout will help to improve ESD robustness.

15 Package Information

15.1 Package Dimensions

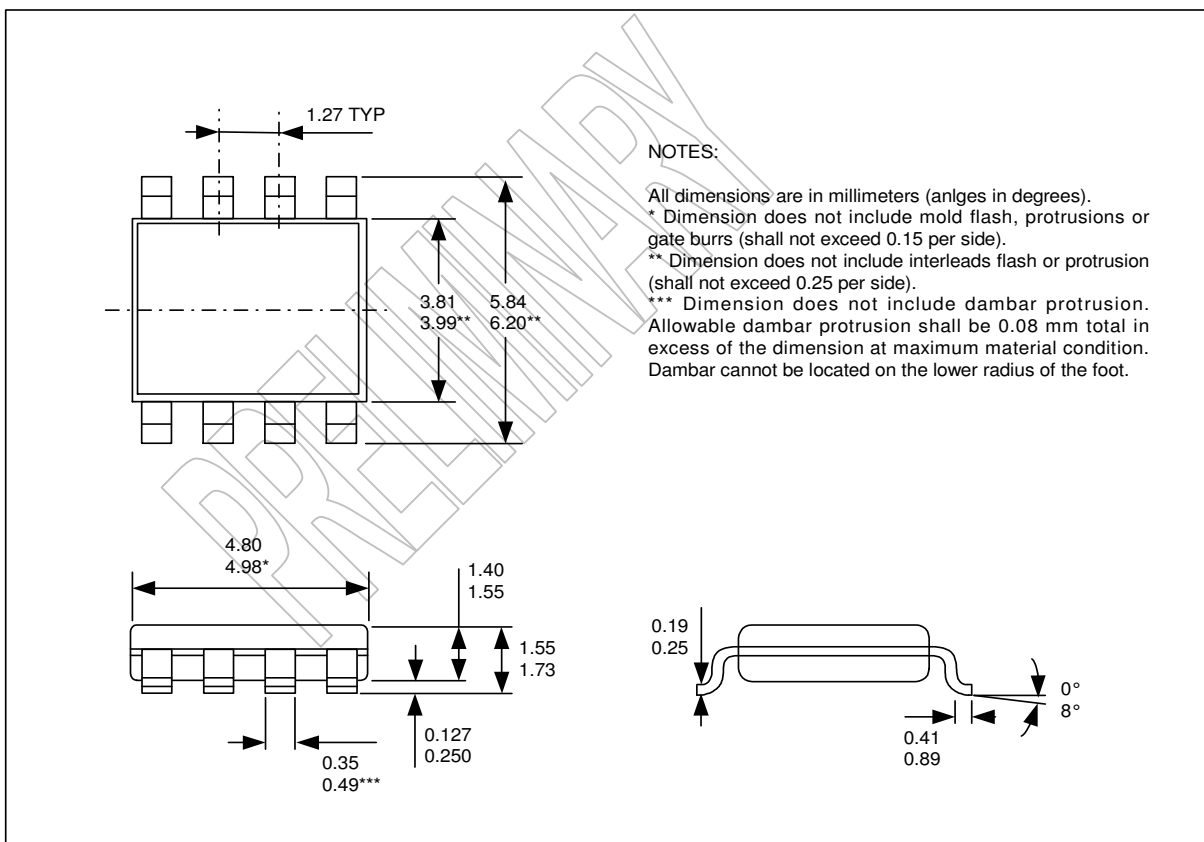

15.2 Pinout and marking

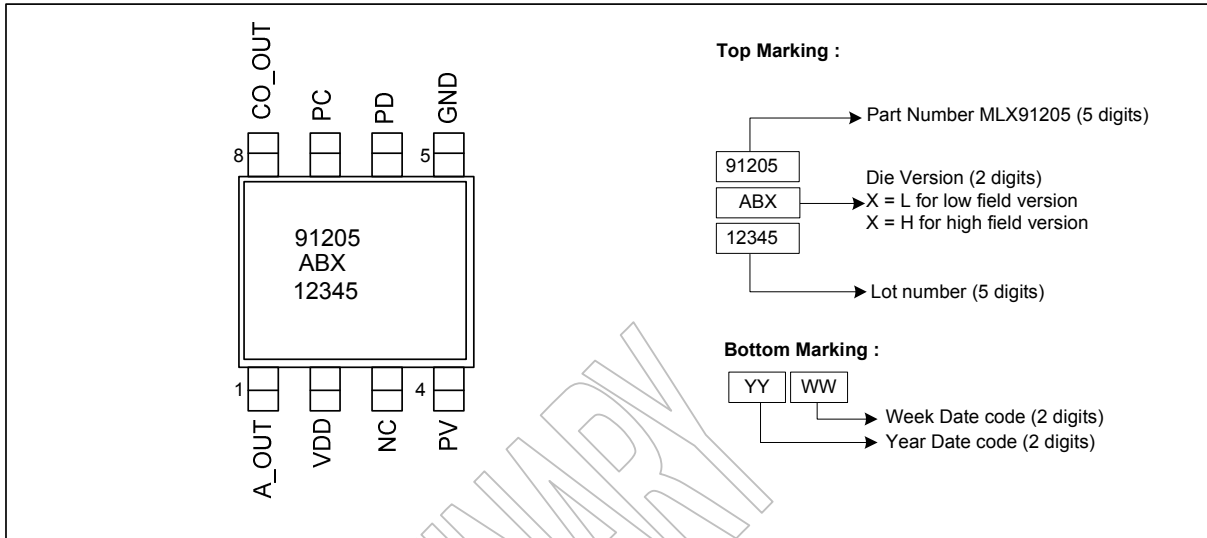

15.3 Hall plate positioning

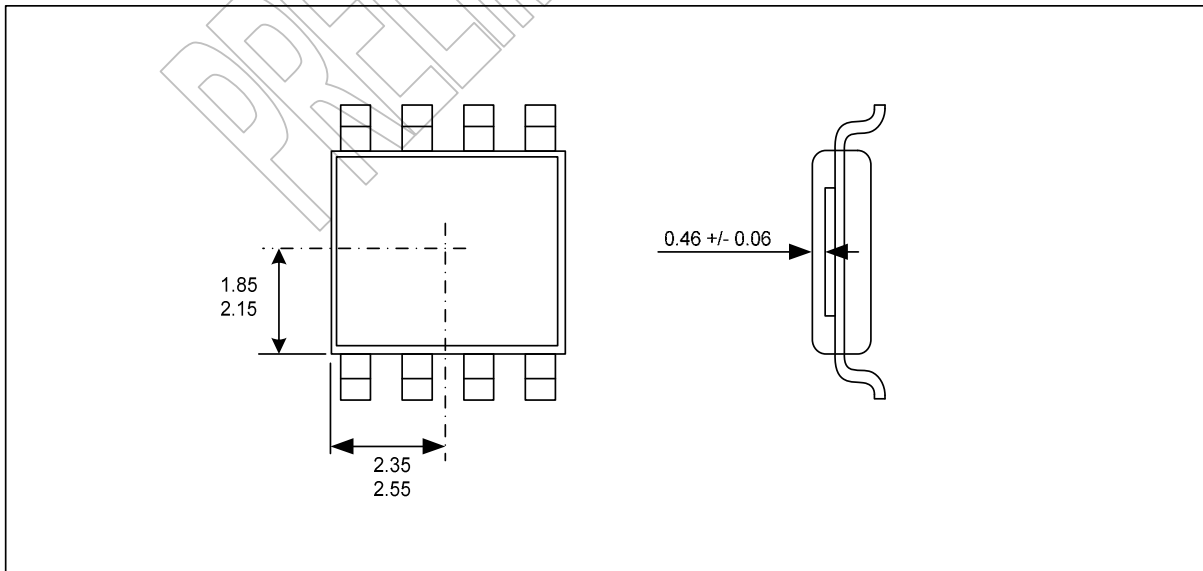

16 Disclaimer

Devices sold by Melexis are covered by the warranty and patent indemnification provisions appearing in its Term of Sale. Melexis makes no warranty, express, statutory, implied, or by description regarding the information set forth herein or regarding the freedom of the described devices from patent infringement. Melexis reserves the right to change specifications and prices at any time and without notice. Therefore, prior to designing this product into a system, it is necessary to check with Melexis for current information. This product is intended for use in normal commercial applications. Applications requiring extended temperature range, unusual environmental requirements, or high reliability applications, such as military, medical life-support or life-sustaining equipment are specifically not recommended without additional processing by Melexis for each application.

The information furnished by Melexis is believed to be correct and accurate. However, Melexis shall not be liable to recipient or any third party for any damages, including but not limited to personal injury, property damage, loss of profits, loss of use, interrupt of business or indirect, special incidental or consequential damages, of any kind, in connection with or arising out of the furnishing, performance or use of the technical data herein. No obligation or liability to recipient or any third party shall arise or flow out of Melexis' rendering of technical or other services.

© 2005 Melexis NV. All rights reserved.

PRELIMINARY

For the latest version of this document, go to our website at
www.melexis.com

Or for additional information contact Melexis Direct:

Europe, Africa, Asia:	America:
Phone: +32 1367 0495	Phone: +1 603 223 2362
E-mail: sales_europe@melexis.com	E-mail: sales_usa@melexis.com

ISO/TS 16949 and ISO14001 Certified