

Six-Decade Counter/Display Decoder

MK50395/6/7(N)

FEATURES

- Single power supply
- Schmitt trigger on the count input
- Six decades of synchronous up/down counting
- Look-ahead carry or borrow
- Loadable counter
- Loadable compare register with comparator output
- Multiplexed BCD and seven-segment outputs
- Internal scan oscillator
- Direct LED segment drive
- Interfaces directly with CMOS logic
- Leading zero blanking
- MK50396 programmed to count time:
99 hrs. 59 min. 59 sec.
- MK50397 programmed to count time:
59 min. 59 sec. 99/100 sec.

DESCRIPTION

The MK50395 is an ion-implanted, P-channel MOS six-decade synchronous up/down counter/display driver with compare register and storage latches. The counter as well as the register can be loaded digit-by-digit with BCD data. The counter has an asynchronous-clear function.

Scanning is controlled by the scan oscillator input which is self-oscillating or can be driven by an external signal. The six-decade register is constantly compared to the state of the six-decade counter and when the register and the counter have the same content, an EQUAL signal is generated. The contents of the counter can be transferred into the 6-digit

PIN CONNECTIONS

Figure 1

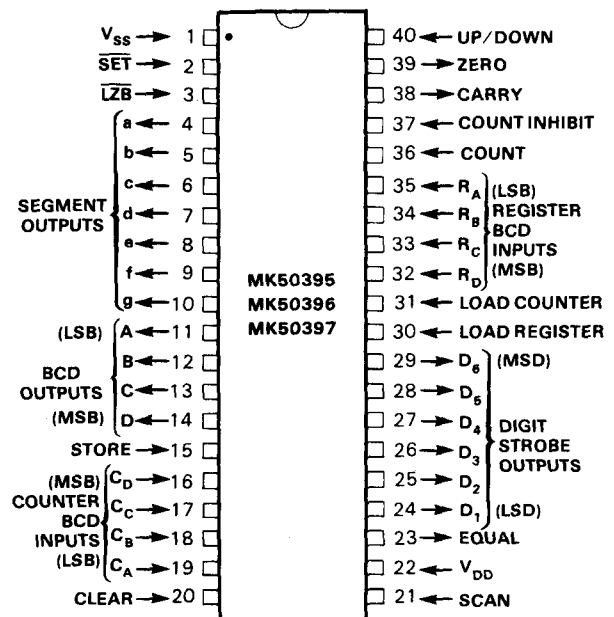

latch which is then multiplexed from MSD to LSD in BCD and 7-segment format to the output. The segment decoder incorporates a leading-zero blanking circuit which can be disabled by an external signal. This device is intended to interface directly with the standard CMOS logic families.

The MK50396 and MK50397 operate identically to the MK50395 except that two digits in each were programmed to provide divide-by-six circuitry instead of divide-by-ten. The MK50396 is well suited for industrial timer applications while the MK50397 is best suited for stop watch or real-time computer clock applications. Pin connections are shown in Figure 1.

BLOCK DIAGRAM

Figure 2

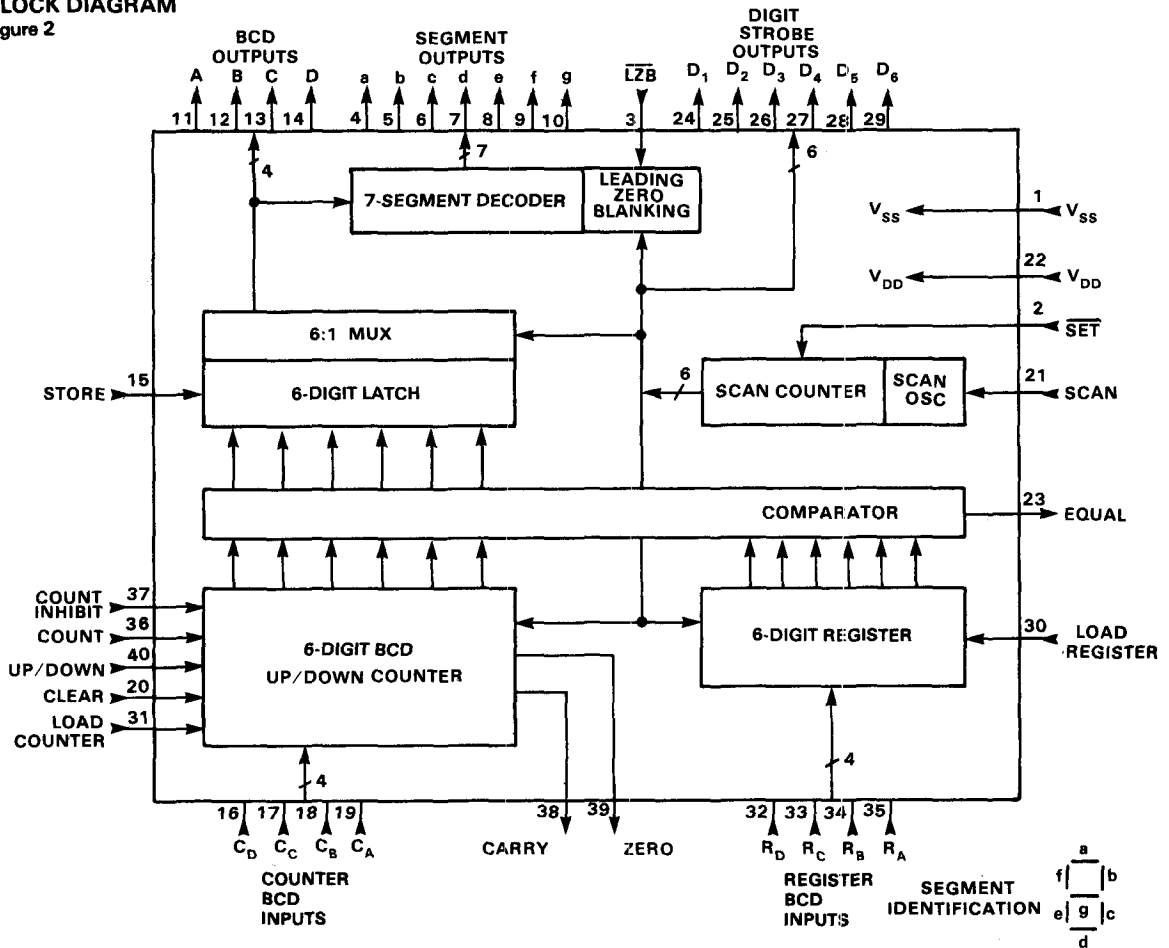

FUNCTIONAL DESCRIPTION (Refer to Figure 2)

V_{SS} , Pin 1

V_{SS} is the positive supply voltage. It should be maintained between 10 and 15 Vdc with respect to V_{DD} .

$\overline{\text{SET}}$, Pin 2

$\overline{\text{SET}}$ is used to exercise control over the scan counter. When a logic 0 level is applied to the $\overline{\text{SET}}$ input, the scan counter is forced to the MSD decade count. During this time, the SEGMENT OUTPUTS are blanked to protect against display burnout.

BCD outputs are valid for MSD when $\overline{\text{SET}}$ is low. Applying a logic 1 level to $\overline{\text{SET}}$ allows normal scan to resume. DIGIT 6 output is active (V_{SS}) until the next scan pulse brings up the DIGIT 5 output.

$\overline{\text{LZB}}$, Pin 3

Bringing $\overline{\text{LZB}}$ low causes leading zeros in the display to be

blanked. Leading zero blanking affects only the SEGMENT OUTPUTS and is disabled by bringing $\overline{\text{LZB}}$ high.

SEGMENT OUTPUTS, Pins 4 through 10

The SEGMENT OUTPUTS are open-drain and capable of sourcing 10 mA average current-per-segment over one digit cycle. Segments are on when at V_{SS} . Segment outputs are blanked during interdigit blanking time.

BCD OUTPUTS, Pins 11 through 14

BCD outputs are push-pull and are on when at V_{SS} . BCD output data changes at the beginning of the interdigit blanking time. Therefore, the BCD output data is valid when the positive transition of a DIGIT OUTPUT occurs.

STORE, Pin 15

The STORE input is used to control the transfer of data from the counter to the display. As long as the STORE input is low, data is continuously transferred from the counter to the display latch. Data in the counter will be latched and displayed

when the STORE input is high. STORE can be changed during the positive transition of the COUNT input.

COUNTER BCD INPUTS, Pins 16 through 19

The COUNTER BCD INPUTS are used to load the counter with BCD information one decade at a time. The counter can therefore be preset to any desired value. Loading is most easily done with the help of the DIGIT STROBE OUTPUTS. BCD thumbwheel switches with four diodes-per-decade connected between the digit strobe outputs and the BCD inputs is one method to supply BCD data for loading the counter decades. (See Figure 5)

CLEAR, Pin 20

The CLEAR input is asynchronous and will reset all decades to zero when brought high. It does not affect the six-digit latch or the scan counter.

SCAN, Pin 21

The MK50395 has an internal scan oscillator. The frequency of the scan oscillator is determined by an external capacitor between V_{SS} or V_{DD} and the SCAN input (see Table 1). The waveform present on the scan oscillator input is triangular in the self-oscillate mode. Typically, the scan oscillator will oscillate at the frequencies shown in Table 1 with capacitors shown connected between V_{SS} and the SCAN input.

An external oscillator may also be used to drive the scan input.

In the external drive mode, the interdigit blanking time will be the sum of the negative dwell period of the external oscillator and the normal self-oscillate blanking time (5-25 μ s). Display brightness can be controlled by the duty cycle of the external scan oscillator.

V_{DD} , Pin 22

V_{DD} is the negative supply input and is normally connected to ground.

EQUAL, Pin 23

The EQUAL output goes high for one count period when the contents of the counter and compare register are equal. The EQUAL output is inhibited by a LOAD COUNTER or LOAD REGISTER operation, which lasts until the next interdigit blanking period following a negative transition of LOAD COUNTER or LOAD REGISTER.

DIGIT STROBE OUTPUTS, Pins 24 through 29

The DIGIT STROBE OUTPUTS are push-pull and are on when at V_{SS} . DIGIT STROBES are decoded internally by a divide-by-six Johnson counter. This counter scans from MSD to LSD. The SET input exercises control over this counter. The DIGIT STROBES are blanked during the interdigit blanking time.

TYPICAL SCAN OSCILLATOR FREQUENCIES

Table 1

C _{SCAN}	Min	Max
820 pF	1.4 kHz	4.8 kHz
470 pF	2.0 kHz	6.8 kHz
120 pF	7.0 kHz	20 kHz

LOAD REGISTER, Pin 30

Applying a logic 1 level to LOAD REGISTER allows the register to be loaded through the REGISTER BCD INPUTS, digit-by-digit, synchronous with the scan counter. (See Figure 4)

LOAD COUNTER, Pin 31

Applying a logic 1 level to LOAD COUNTER allows the counter to be loaded through the COUNTER BCD INPUTS, digit-by-digit, synchronous with the scan counter. (See Figure 4)

REGISTER BCD INPUTS, Pins 32 through 35

The register is loaded identically as described in the COUNTER BCD INPUT paragraph. The register may be loaded independently of the counter. However, the CLEAR input will not remove the register contents. Contents of the register are not displayed by the BCD or SEGMENT OUTPUTS.

COUNT, Pin 36

The six-decade counter is synchronously incremented or decremented on the positive edge of the COUNT input signal. A Schmitt trigger on this input provides hysteresis for protection against both a noisy environment and double triggering due to a slow rising edge at the COUNT input. A count frequency of 1 MHz can be achieved if the EQUAL output, ZERO output, and CARRY output are not used. These outputs do not respond at this frequency due to their output delay, as illustrated on the timing diagram, Figure 3.

COUNT INHIBIT, Pin 37

A logic 1 level activates COUNT INHIBIT. The COUNT INHIBIT can be changed during the positive transition of the COUNT input.

CARRY, Pin 38

The CARRY output goes high with the leading edge of the COUNT input at the count of 000000 when counting up or at 999999* when counting down and goes low with the

*Carry occurs at 99 59 59 for the MK50396 and 59 59 99 for the MK50397

COUNTER DISPLAY DECODERS

negative going edge of the same COUNT input. CARRY is a push-pull output.

edge of the count input and is also a push-pull output.

ZERO, Pin 39

The ZERO output goes high for one COUNT period when all decades contain zero. During a LOAD COUNTER operation, the ZERO output is inhibited. ZERO changes on the leading

UP/DOWN, Pin 40

The counter will increment when the UP/DOWN input is high (V_{SS}) and will decrement when the UP/DOWN input is low. The UP/DOWN input can be changed 0.75 μ s prior to the positive transition of the count input.

ABSOLUTE MAXIMUM RATINGS*

Voltage on Any Terminal Relative to V_{SS}	+0.3 V to -20 V
Operating Temperature Range (Ambient)	0°C to +70°C
Storage Temperature Range (Ambient)	-40°C to +100°C

*Stresses above those listed under "Absolute Maximum Ratings" may cause permanent damage to the device. This is a stress rating only and functional operation of the device at these or any other condition above those indicated in the operational sections of this specification is not implied. Exposure to absolute maximum rating conditions for extended periods may affect device reliability.

ELECTRICAL CHARACTERISTICS

DC CHARACTERISTICS

($V_{DD} = 0$ V, $+10.0$ V $\leq V_{SS} \leq +15.0$ V, $0^\circ\text{C} \leq T_A \leq 70^\circ\text{C}$)

SYM	PARAMETER	MIN	MAX	UNITS	NOTES
T_A	Operating Temperature	0	70	°C	
V_{SS}	Supply Voltage ($V_{DD} = 0$)	10	15	V	
I_{SS}	Supply Current		30	mA	1
B_V	Break-Down Voltage (Segment only @ 10 μ A)		$V_{SS} - 26$	V	
P_D	Power Dissipation		670	mW	2
V_{IL}	Input Low Voltage, "0"	V_{DD}	0.2 (V_{SS})	V	
V_{IH}	Input High Voltage, "1"	$V_{SS} - 1$	V_{SS}	V	3
V_{OL}	Output Voltage "0" @ 30 μ A		0.2(V_{SS})	V	4
V_{OH}	Output Voltage "1" @ 1.5 mA	0.8 (V_{SS})		V	4
I_{OH}	Output Current "1" Digit strobes Segment outputs	3.0 10.0		mA mA	5 6
I_{SCAN}	Scan Input Pull-Up Current @ 0 V		5.5	mA	
I_{SCAN}	Scan Input Pull-Down Current @ 15 V	2	40	μ A	
I_{SET}	$\overline{\text{SET}}$ Input Pull-Up Current @ 0 V	5	60	μ A	

AC CHARACTERISTICS

($V_{DD} = 0\text{ V}$, $+10.0\text{ V} \leq V_{SS} \leq +15.0\text{ V}$, $0^\circ\text{C} \leq T_A \leq 70^\circ\text{C}$)

SYM	PARAMETER	MIN	MAX	UNITS	NOTES
f_{CI}	Count Input Frequency	0	1.00	MHz	7,8
f_{SI}	Scan Input Frequency	0	20	kHz	
t_{CPW}	Count Pulse Width	400		ns	9
t_{SPW}	Store Pulse Width	2.0		μs	
t_{SS}	Store Set-Up Time	0		μs	10
t_{CIS}	Count Inhibit Set-Up Time	0		μs	10
t_{UDS}	Up/Down Set-Up Time	0.75		μs	10
t_{CLPW}	Clear Pulse Width	2.0		μs	10
t_{CS}	Clear Set-Up Time	0.5		μs	10
t_{OA}	Zero Access Time		3.0	μs	10
t_{OH}	Zero Hold Time		1.5	μs	10
t_{CA}	Carry Access Time		1.5	μs	10
t_{CH}	Carry Hold Time		0.9	μs	11
t_{EA}	Equal Access Time		2.0	μs	10
t_{EH}	Equal Hold Time		1.5	μs	10
t_L	Load Time	$6/f_{SI}$		s	
t_{LS}	Load Set-Up Time	2.0		μs	12
t_{DV}	Data Valid Time	2.0		μs	13

NOTES:

1. I_{SS} with inputs and outputs open at 0°C . 28 mA at 25°C and 25 mA at 70°C . This does not include segment current. Total power per segment must be limited so as not to exceed power dissipation of package. ($\theta_{JA} = 100^\circ\text{C}/\text{Watt}$)
2. All outputs loaded.
3. Min V_{IH} from R_A R_B R_C R_D C_A C_B C_C C_D inputs is $V_{SS} - 2.5\text{ V}$. Those inputs have internal pull-down resistors to V_{DD} .
4. This applies to the push-pull CMOS-compatible outputs. Does not include digit strobes or segment outputs.
5. For $V_{OUT} = V_{SS} - 2.0\text{ Volts}$. Average value over one digit cycle.
6. For $V_{OUT} = V_{SS} - 3.0\text{ Volts}$. Average value over one digit cycle.
7. Measured at 50% duty cycle.
8. If CARRY, EQUAL, or ZERO outputs are used, the count frequency will be limited by their respective output times.
9. The COUNT pulse width must be greater than the CARRY access time when using the CARRY output.
10. Measured from positive edge of COUNT input 10% level.
11. Measured from negative edge of COUNT input 90% level.
12. Measured from positive transition of DIGIT output 10% level.
13. Measured from negative transition of DIGIT output 90% level.

TIMING DIAGRAMS

Figure 3

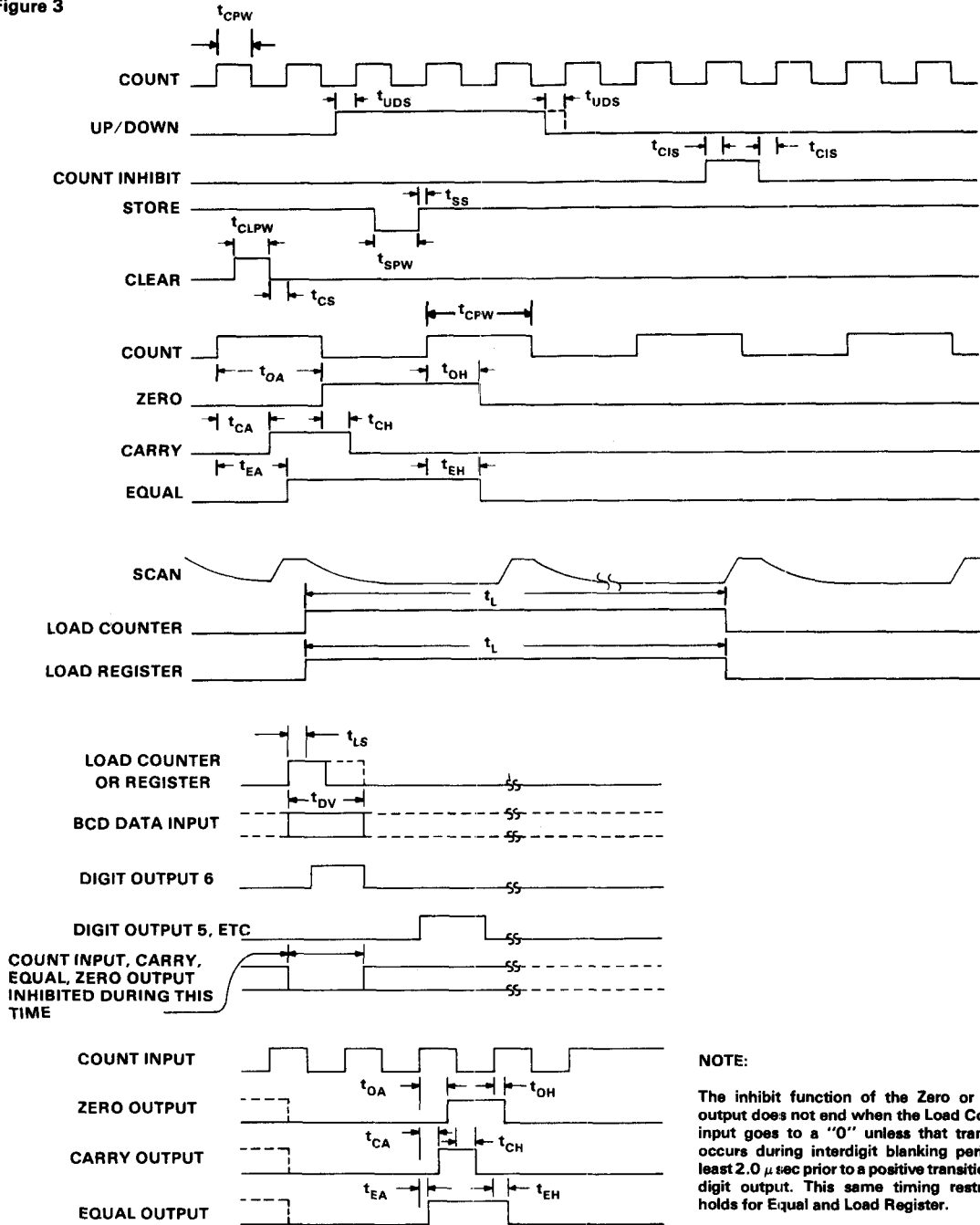

NOTE:
 The inhibit function of the Zero or Equal output does not end when the Load Counter input goes to a "0" unless that transition occurs during interdigit blanking period at least 2.0 μ sec prior to a positive transition of a digit output. This same timing restriction holds for Equal and Load Register.

LOAD COUNTER, REGISTER TIMING

Figure 4

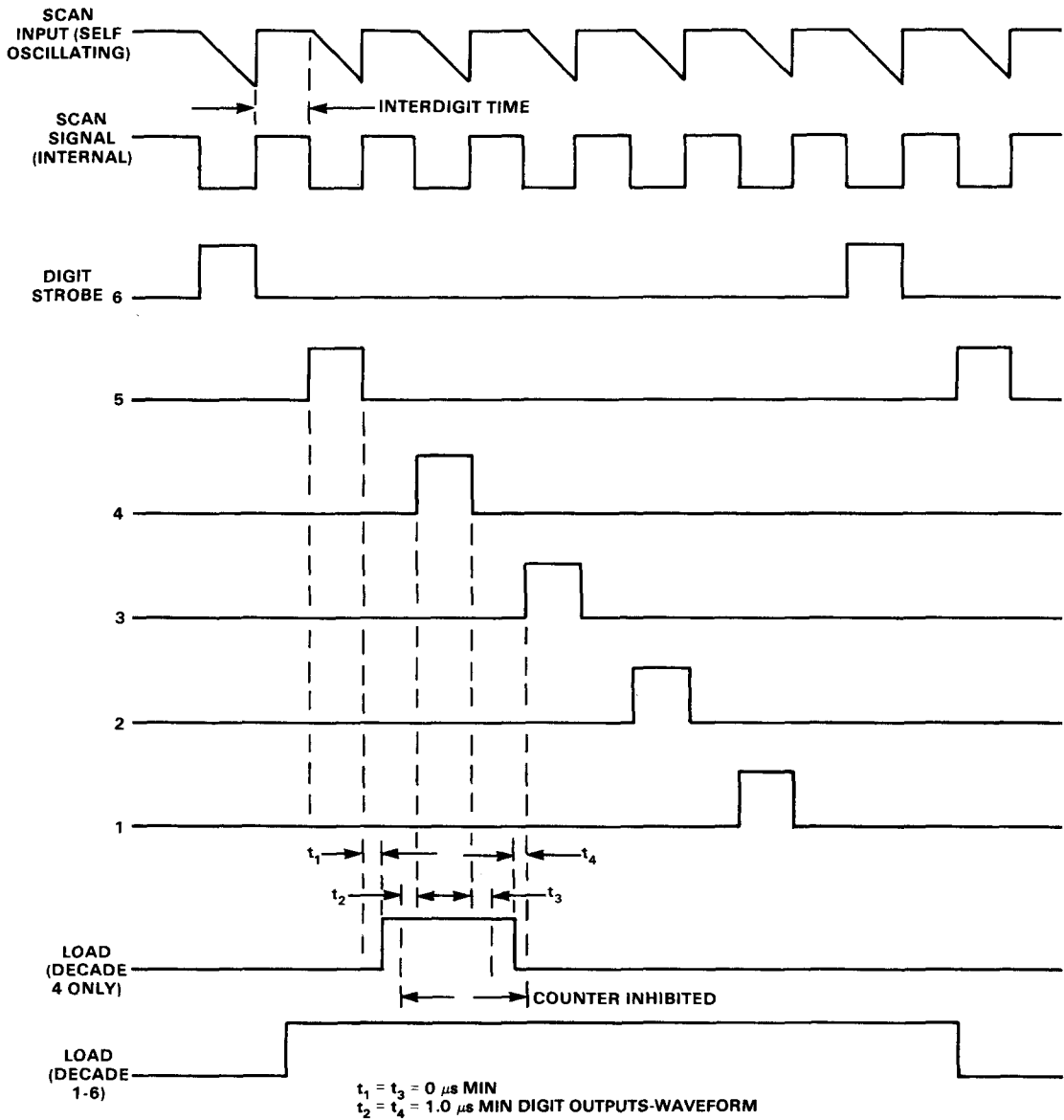

V
COUNTER
DISPLAY
DECODERS

BCD SWITCH MATRIX
Figure 5

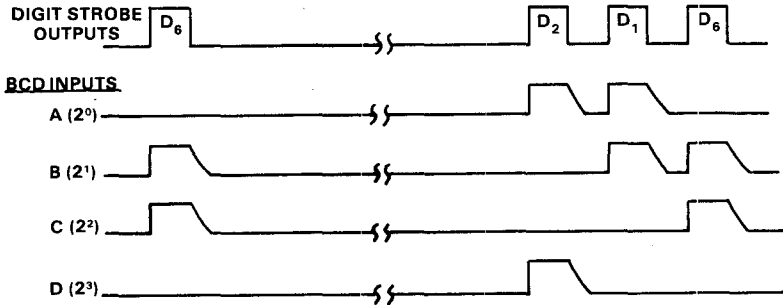
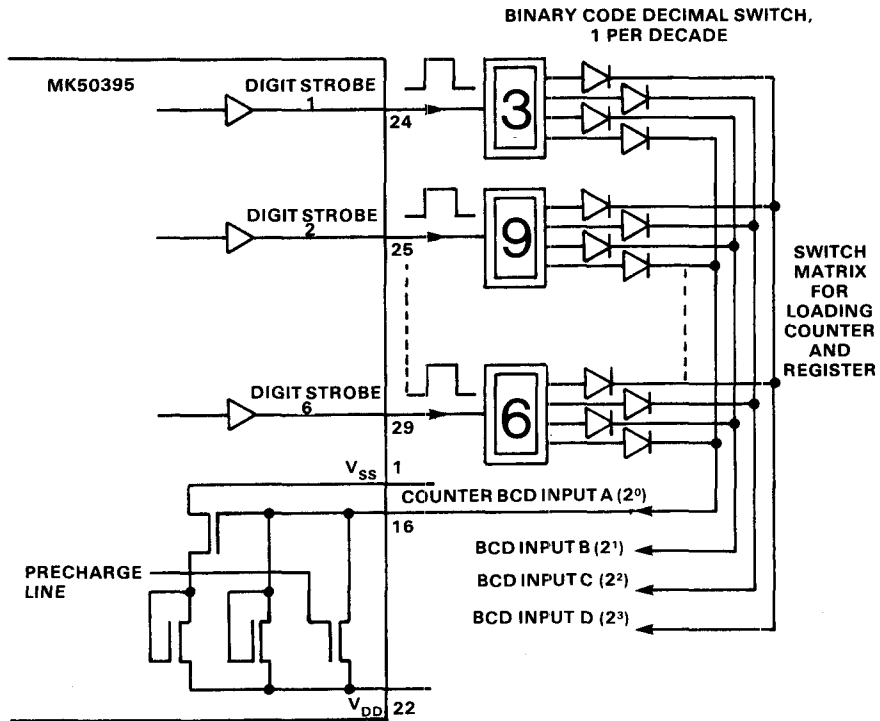

NOTE THAT ALL INPUT LINES ARE ALL PULLED TO V_{DD} DURING
 INTERDIGIT BLANKING

DARK ROOM TIMER TYPICAL APPLICATION

Figure 6

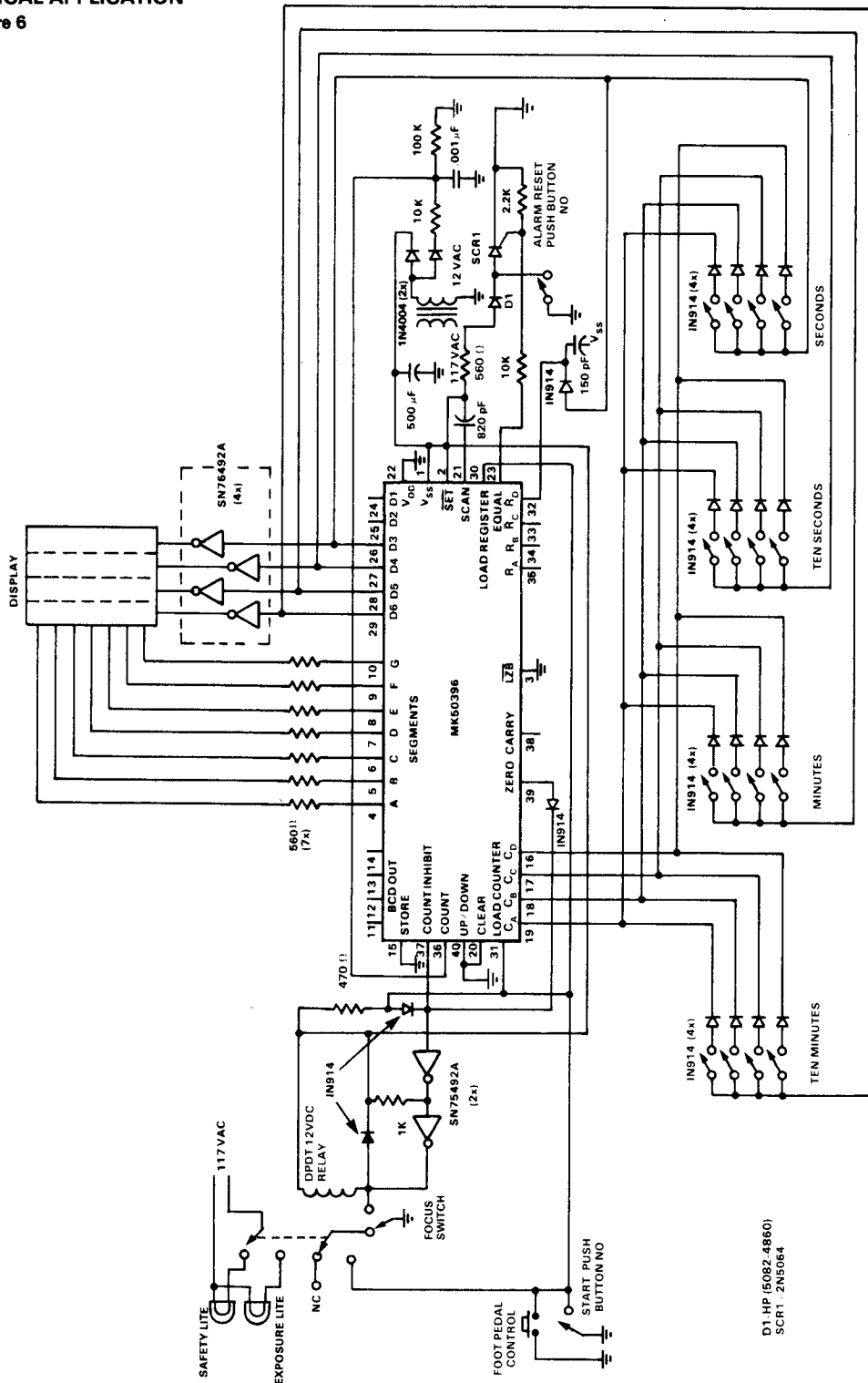

V
COUNTER
DISPLAY
DECODERS

D1-HP 5082-4860
SCRT1-2N5064

UP/DOWN COUNT TIMING

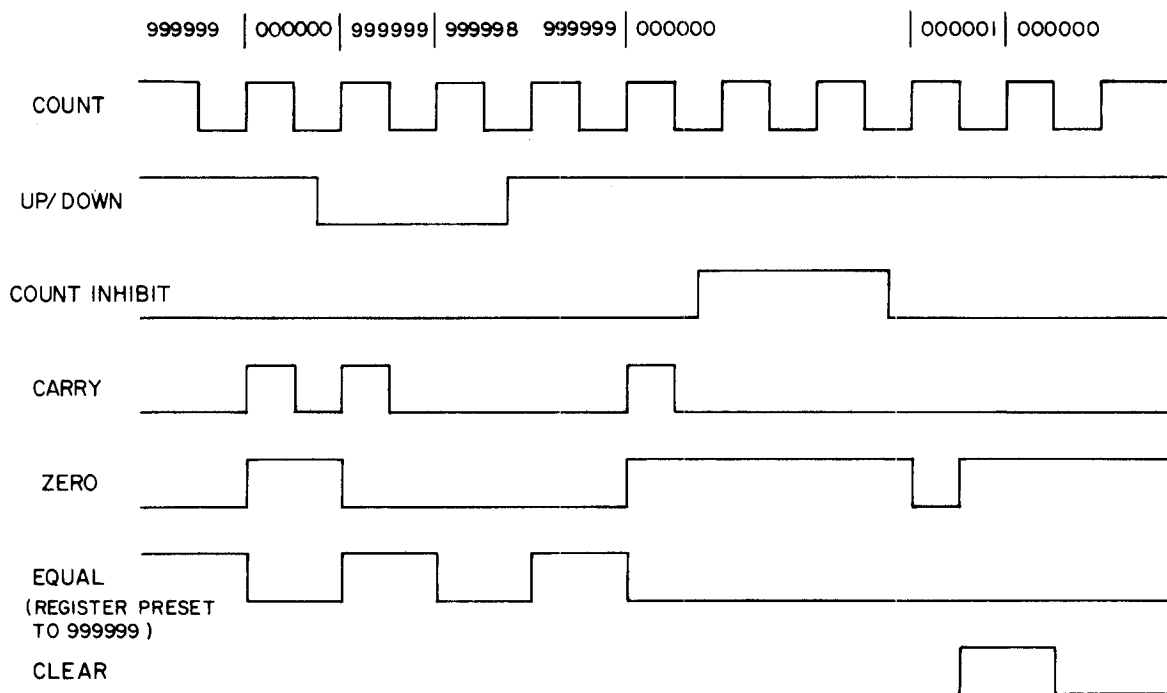

as for the counter. The value on the REGISTER BCD INPUTS is loaded decade-by-decade by the six digit signals in the order "most significant" (digit 6) to "least significant" (digit 1). The outputs of this register are compared continuously with the value currently in the counter. This comparison is made in parallel and not decade-by-decade. When the two values are the same, an EQUAL signal is given. However, during presetting of the counter the CARRY, ZERO and EQUAL signals are inhibited so that no false, intermediate comparison result is given. Since the counter and the register have separate BCD inputs, both may be preset simultaneously if desired. The value held in the register can only be altered by the BCD inputs. The Count Input is not inhibited during load register operations.

DIGIT SCANNING AND OUTPUT FUNCTIONS

The digit scan counter is timed from an internal oscillator which may be driven externally from the SCAN input. A capacitor attached from V_{SS} to this pin will determine the scan frequency when external logic drive to this pin is not used. Internal circuitry gives a fixed delay to the DIGIT OUTPUT signal to ensure that there is a gap between each digit strobe so that a "ghosting" effect in a displayed output due to the storage time of external display driver transistors is eliminated. This is the interdigit blanking time. Typically, this time can range from 3 to 10 microseconds.

LOAD COUNTER, REGISTER TIMING

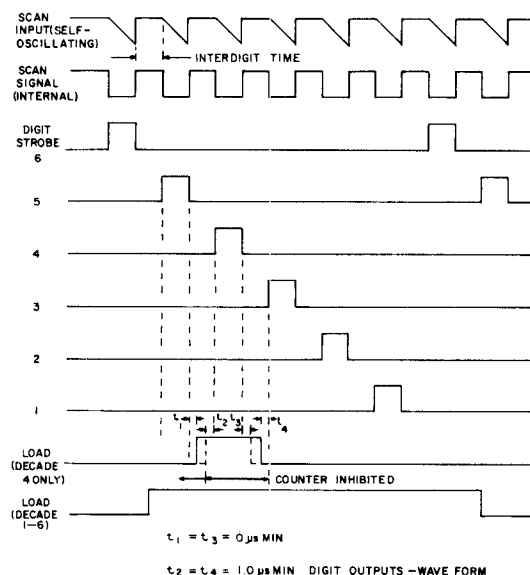

the **SET** input is used to force the digit strobe counter to the digit 6 position for purposes of synchronizing the counter output. The digit counter outputs are gated by the interdigit blanking period and appear as **DIGIT STROBE OUTPUTS**. The counter outputs are not directly multiplexed but are buffered by a 6-digit latch controlled by the **STORE** command. The out-puts of the latch go directly to the output multiplexer. Thus, when the **STORE** signal is at logic 0, the counter contents are directly available, but as soon as **STORE** goes to logic 1, the value present as the signal changed is retained and subsequent changes in counter value are ignored. The contents of the store are read out, digit-by-digit — the scan counter again performs this function in the order most-significant to least-significant — and appear on **BCD OUT** pins. The four bits in each BCD digit are encoded simultaneously to seven-segment code and appear as **SEGMENTS OUT** and can be used to drive a suitable 7-segment display. The **SET** operation will also turn off these seven outputs, blanking the display, as well as setting the digit counter to digit 6. This is to prevent possible destruction of an LED-type display when **SET** is a prolonged signal. Frequently it is required to display only significant numbers, in which case taking the **LZB** control to a logic 0 will blank the leading zeros in the seven-segment output.

INTERFACING WITH THE MK 50395

The wide range of power supply, 10.0 – 15.0 volts, makes the counting system particularly suitable for interfacing with CMOS logic.

- A. Segment output — these transistors can source 10 mA from the V_{SS} supply. There is no internal pull-down to V_{DD} when the transistor is turned off. These transistors are capable of driving small LED displays directly via series resistors.
- B. Digit outputs — a push-pull configuration is used here as the most suitable arrangement for driving both external logic and display drivers. These outputs supply 3.0 mA max from V_{SS} and sink 30 μ A to V_{DD} .

When higher-power displays are used, the segment outputs should be buffered by an emitter follower in order to provide the extra current. The **BCD OUTPUTS**, **EQUAL**, **ZERO** and **CARRY** are also push-pull. Output drive capabilities are listed in the following table:

Segment Output (Pins 4-10)	V_{OL}	V_{OH} $V_{SS} - 3V$ at 10mA (average over one digit strobe cycle)
Digit Outputs (Pins 24-29)	V_{DD} at no load 20% of V_{SS} at 30 μ A	$V_{SS} - 2V$ at 3.0mA
Equal/Zero/Carry (Pins 23,39,38)	V_{DD} at no load 20% of V_{SS} at 30 μ A	$V_{SS} - 2V$ at 1.5mA

The following inputs, **COUNT**, **STORE**, **UP/DOWN**, **COUNT INHIBIT**, **CLEAR**, **LZB**, **LOAD REGISTER** have no internal current sources and must therefore be driven from sources that give correct logic 1 and 0

SEGMENT DRIVER

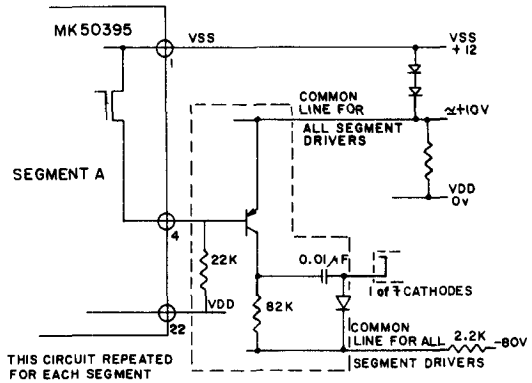

DIGIT DRIVER

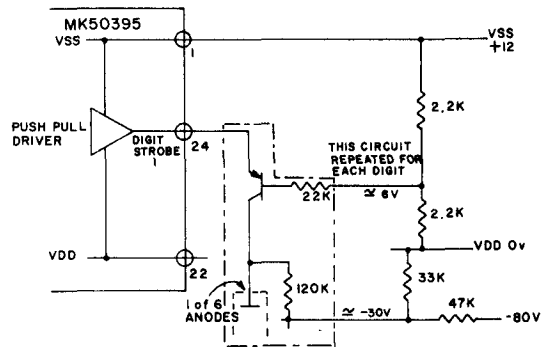

DRIVING LED DISPLAYS DIRECTLY

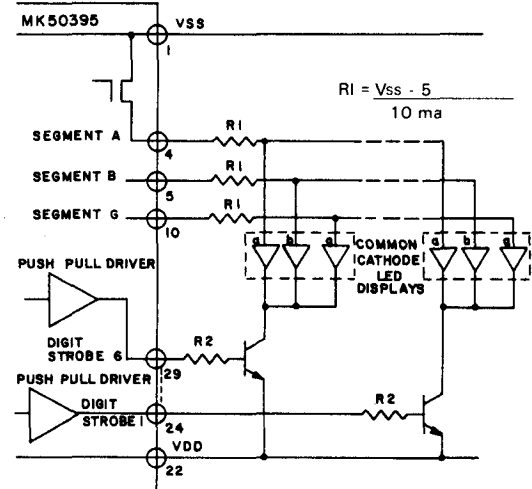

V
COUNTER
DISPLAY
DECODERS

levels - open collector circuits, or switches without pull down resistors for example, may not be used. If any of the above functions are not required then those pins should be tied to the appropriate supply, that is to V_{SS} for logic 1 and V_{DD} for logic 0. SET has an internal transistor that pulls the pin to V_{SS} if unconnected thus the driving circuit should be able to sink this current, approximately $60 \mu A$, when pulling the input to logic 0. The COUNTER BCD and REGISTER BCD inputs have two internal transistors one static and one switched as a precharge, that pull to V_{DD} . The static current is $< 350 \mu A$ to V_{DD} when the input is taken to V_{SS} , the dynamic current from V_{SS} is 1 mA while the transistor is on. The dynamic precharge ensures that even with the large capacitive loading and leakage current of a switch matrix at these pins, the correct data will be entered at the maximum digit scan frequency.

An example of a switch matrix input illustrates this operation. Six binary-coded-decimal switches are used, one for each decade, the switches being enabled by the corresponding DIGIT STROBE output, with the paralleled switch outputs connected to the COUNTER (or REGISTER) BCD inputs. The DIGIT STROBE outputs are separated by the interdigit blanking time and it is only during this time that the precharge transistors at the BCD inputs are all pulled to logic 0 (V_{DD}). After this blanking time, the next DIGIT STROBE output will in its turn switch to logic 1 (only one out of six is ever on) and pull those BCD inputs selected by the switch and diode matrix to logic 1. This value is loaded into the corresponding register or counter stage, i.e. the switch matrix driven by DIGIT STROBE 6 will be loaded into MSD of the

BCD SWITCH MATRIX

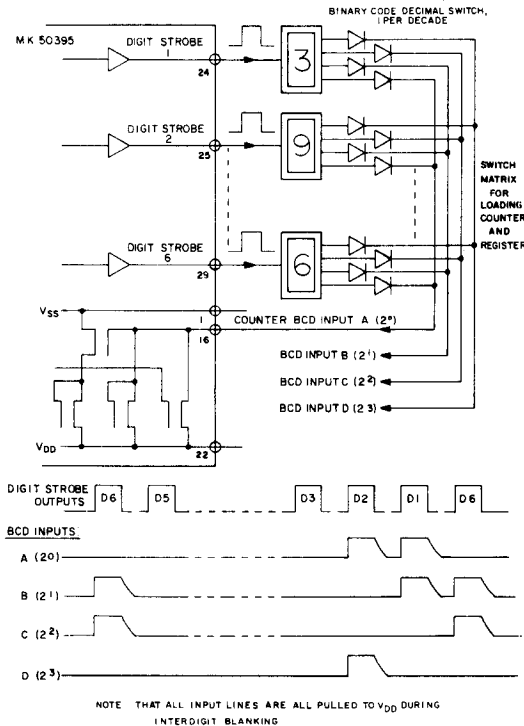

register or counter. As the DIGIT STROBE switches back to logic 0, the next interdigit blanking time begins and the inputs are all pulled back to logic 0 again by the internal precharge. It is possible for the DIGIT STROBE outputs to drive both the switch matrix and a display. If the COUNTER & REGISTER BCD inputs are connected in parallel they may still be driven directly from the DIGIT STROBE outputs.

SCAN FREQUENCY VS EXTERNAL CAPACITANCE

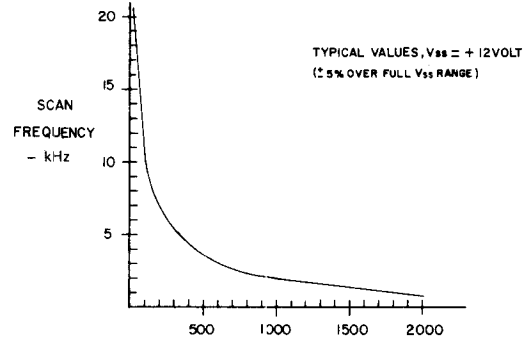

Additional Capacitance on Pin 21 (pF)

When the scan oscillator is free running, the SCAN input may use an external capacitor to set the scanning frequency to a particular value. The signal seen at the pin is a ramp determined by the capacitance, followed by a period clamped at V_{SS} . This period clamped at V_{SS} is determined by the internal oscillator and is the interdigit blanking period. During this time, the DIGIT STROBE outputs are all turned off. When the SCAN input is driven externally, this fixed interdigit period remains plus the time at which the synchronizing signal is at logic 0. To make the interdigit blanking time independent of the external synchronizing signal requires only the addition of a resistor and capacitor as shown on page 50.

Referring to the External Drive To Scan Input drawing on page 50, time a is the interdigit blanking time.

Time b should be greater than $2\mu s$ —a range of $2-5\mu s$ is suitable—and time c may be from infinity to $30\mu s$. If time c is made too short, then the interdigit blanking circuit never resets itself and will stay at logic 0 and no DIGIT STROBE outputs will appear.

TYPICAL MK 50395 APPLICATIONS

BATCH CONTROL

In many situations involving the metering of material, whether as a liquid, individual items or revolutions of a spindle, a two-step operation is required for better efficiency. The flow is started at the maximum speed and at a preset point before the end of the operation a signal is required to slow down and eventually stop the equipment. Such applications could be as diverse as filling sacks with cement or controlling the turns on a transformer bobbin. In the system shown on page 50, pressing the start switch allows the input to the D flip-flop to go to logic 1. This is clocked by DIGIT STROBE 6 so that a synchronous signal at least one complete scan counter cycle

EXTERNAL DRIVE TO SCAN INPUT

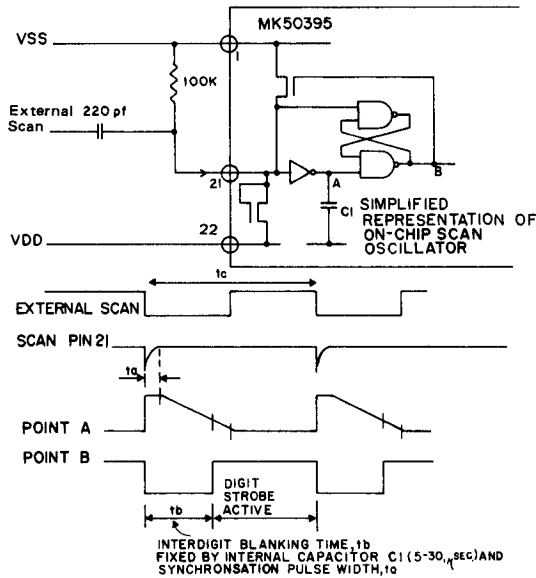

long is obtained. This signal is used as LOAD COUNTER and LOAD REGISTER, the two controls being tied in parallel for simultaneous loading. It does not matter how long the load signal is so long as it is at least one scan cycle long and changes synchronously with the scan signal. The two values representing total quantity and "slow-down" quantity are set on the digit switches and these values are loaded at the beginning of each cycle. Once the counter register loading is complete, a start signal is generated to set the equipment in operation. While the train of pulses representing the measured quantity is counted, the UP/DOWN control is in the down mode. Thus with two quantities at, let us say, 10,000 and 500 the counter starts off with 10,000 loaded and counts toward zero. When the counter reaches 500, an EQUAL signal is generated and this sets the signal controlling the brake. After a further 500 pulses, the counter reaches zero, an output on the ZERO pin resets the start flip flop and the equipment is brought to reset awaiting a new start signal. In such an operation the display outputs would probably not be used.

This application can be extended by using the ZERO output to control the UP/DOWN input. The operation is identical but the start signal also sets a latch into the count down state. As ZERO is detected this latch is reset so that the counter mode is now up. Even with a braking facility there may be an "overrun" and the value now held in the counter and displayed is the extra quantity. The operator may now decide if this extra quantity is within the tolerance allowed for the job and to take whatever action is necessary.

POSITIONAL MEASUREMENT

Positional measurement can readily be made using this circuit. The six decades gives considerable ac-

BATCH CONTROL

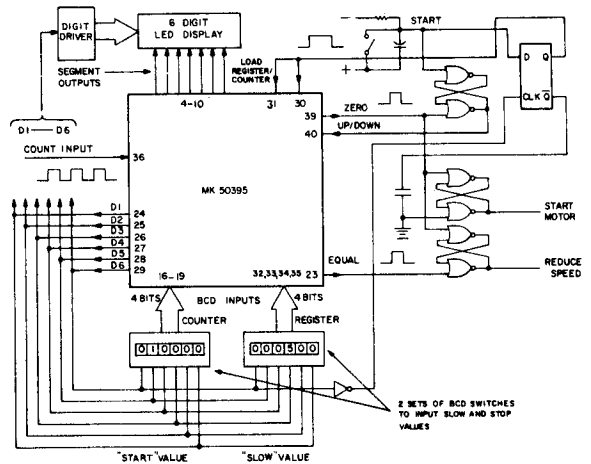

curacy in one package. The two quadrature signals from a graticule-type displacement measurement system must be converted to count impulses and an UP/DOWN signal. If the measurement zero datum is in the middle of the measurement area then the following counting conditions arise:

Direction of Movement	Displayed sign + or - of Datum	Count direction	
RIGHT	-	DOWN	ZERO DATUM CROSSED
RIGHT	+	UP	
LEFT	+	DOWN	ZERO DATUM CROSSED
LEFT	-	UP	

Each time the zero datum is reached and each time the direction of movement is changed, the count direction must be changed. The value displayed thus represents the position either side of the zero datum. The storage register may be used as a means of limiting the travel of the measurement piece. If a value equal to the limit is loaded into the register, the EQUAL output may be used to give a warning that the limit is reached.

It will have been noted from the delay of EQUAL and ZERO to the COUNT edge that ZERO has much longer propagation delay than the EQUAL output. In the event that the register is not used, it may be loaded with zeros — by giving a LOAD REGISTER command with the BCD inputs as zero — and the EQUAL output then used as zero detect. This has the advantage of increasing the system speed, for, although the counter can accept inputs up to 1.0 MHz, the propagation delay of the outputs is too long to allow a control signal to be changed between clock pulses at this counting rate. In this example, UP/DOWN has to be controlled, and using the faster out-

COUNTER DISPLAY DECODERS

POSITIONAL MEASUREMENT

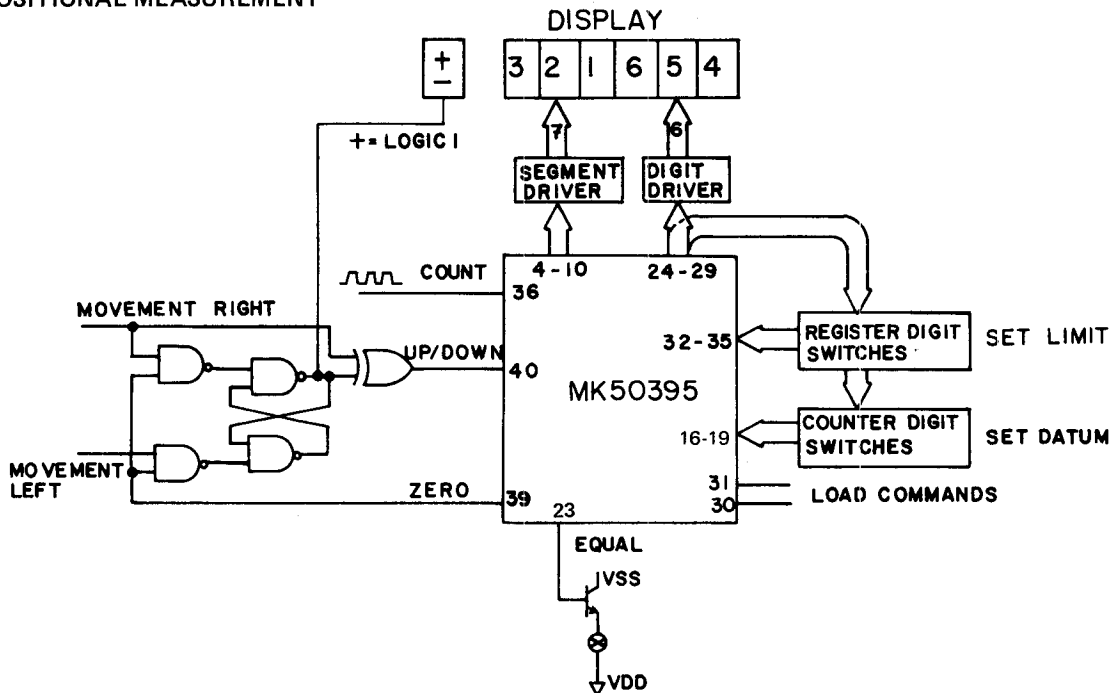

put enables a higher counting speed, 600 kHz instead of 300 kHz, to be used if necessary.

GREATER THAN – LESS THAN DETECTION

The availability of an EQUAL output facilitates the generation of greater-than and less-than signals. The only requirement is that the circuit is set into the correct initial state. When the counter has the same value as the register, the generation of the "greater/less than" signal depends on the direction of count, i.e. from this EQUAL condition count up gives "greater than" and count down gives "less than". EQUAL is gated with UP and with DOWN and these are connected to the D inputs of two D flip-flops that are both clocked by the counting pulse. As EQUAL is reached, the two flip flops are reset but the next count pulse after the EQUAL condition will set one of the flip flops and thereby provide the appropriate signal.

AUTOMATIC STOP

The COUNT INHIBIT input may be used to stop the counter automatically when the EQUAL or ZERO outputs are connected directly to this input. As EQUAL, for example, goes to a logic 1, then further counting is inhibited when this signal is connected directly to COUNT INHIBIT. Since no more count inputs are accepted, the EQUAL value remains and blocks the counting action. The operation of CLEAR, LOAD REGISTER or LOAD COUNTER can be used to start the system counting again.

GREATER THAN – LESS THAN

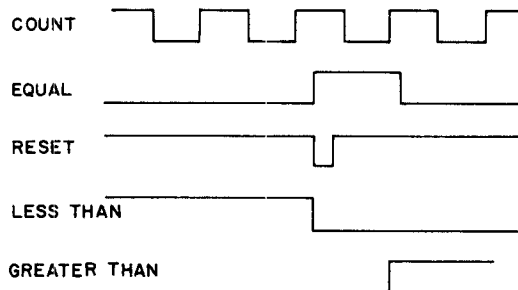
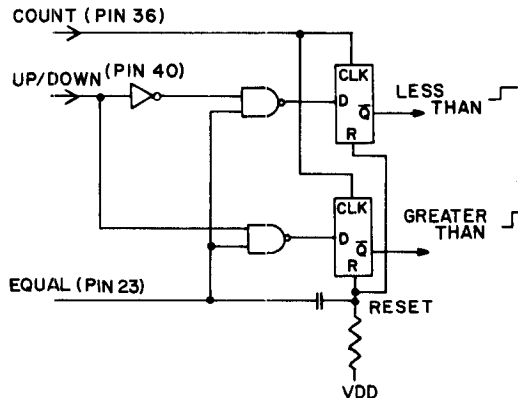

SN 7490 TIMING

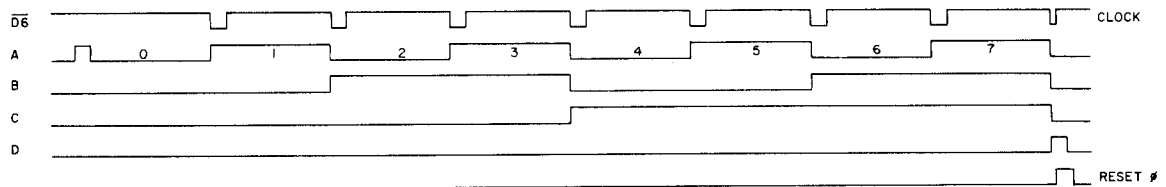

SN 74151 LOAD COUNTER PULSE TRAIN OUTPUT

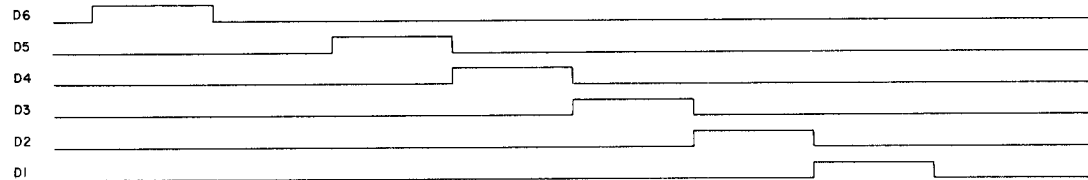

SN 74151 OUTPUT TO BCD LATCH ENABLE

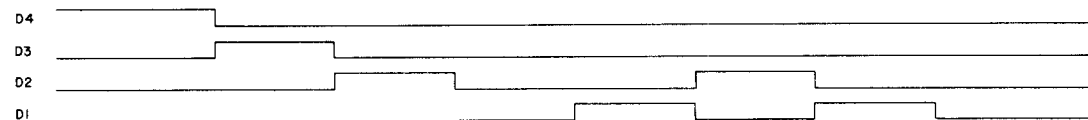

SN74151's DECODE
A = $\bar{A} \cdot B \cdot C$ B = $A \cdot \bar{B} \cdot C$

MORE APPLICATIONS

The following applications resulted from an ad contest sponsored by Mostek. These applications represent a cross section of uses for the MK 50395 family and are intended as a guide for applying the counter circuit.

The type of display is left to the user to design into his particular application. The MK 50395 series was designed to allow direct drive of efficient display systems. If the current requirements of a display exceed the specifications of the MK 50395 series, external segment drive circuitry will be required.

Power supply voltage range, wattage, filtering, and decoupling must be observed in all applications. The MK 50395 series was designed to keep power supply restrictions to a minimum.

100 MHz FREQUENCY COUNTER

In most counter applications, the problems associated with prescaling result in a loss of resolution, or the need for longer count sample times. This application allows the MK 50395 with some associated circuitry to count at 100 MHz with a one-second gate time achieving one-Hz resolution.

The MK 50395 counts the input frequency after a divide-by-100 using an SN74S196 and an SN74196. Frequency sample time is achieved by a one MHz crystal in conjunction with the MK 5009 time base in the $\div 10^6$ configuration, followed by a divide-by-

two to give a one-second logic one level. This is applied to the count/load input of the SN74S196 and SN74196 counters. The 10's-of-Hz and one's-of-Hz data is retained in these two counters for later display. Actually, only a count of 99.9999 MHz may be displayed as the MK 50395 would display all zeros and a carry would be generated at the next higher count.

At the end of the one-second sample time, a store is generated and the count data is latched into the display.

A clear counter pulse is generated to ready the MK 50395 for the next data cycle. If the MHz-Hz switch is in the MHz position, the preceding cycle will again occur at the next gate sample time. Load counter is also disabled in the MHz position.

With the MHz-Hz switch in the Hz position, the first $\frac{1}{2}$ SN7474 is enabled and is clocked at the end of every pulse, which clears the MK 50395. The second SN7474 also changes state, enabling the SN74151 which controls the MK 50395 load counter input, and the Hz cycle begins.

At the end of every clear MK 50395 pulse, \overline{SET} is brought low to sync the MK 50395 with the rest of the circuitry.

The MK 50395 loads digit Six with digit Four data into the BCD counter. The digit four data was stored in the SN7475 latch at the previous digit four time.

V
COUNTER
DISPLAY
DECODERS

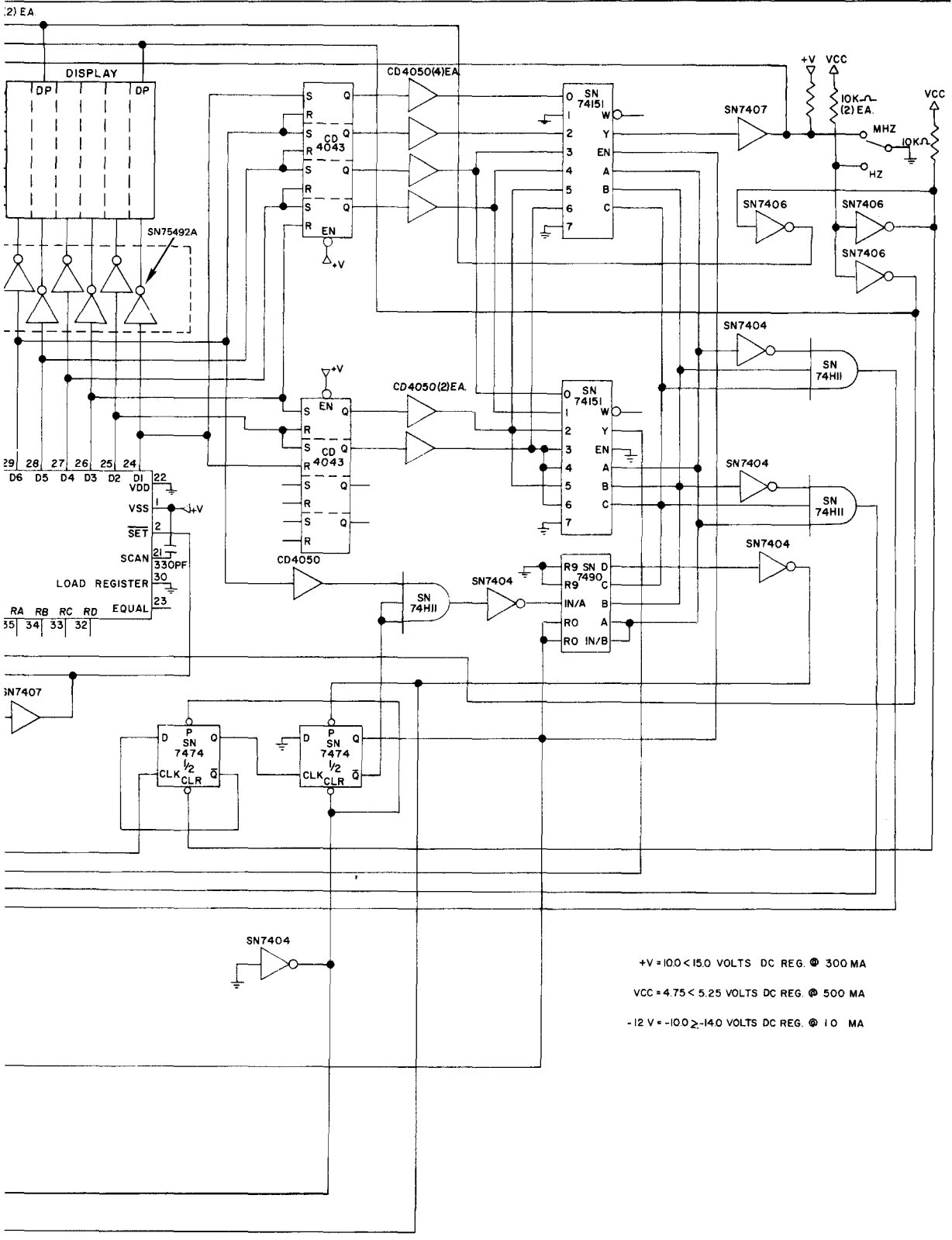

V
 COUNTER
 DECODERS

+V = 10.0 < 15.0 VOLTS DC REG. @ 300 MA
 VCC = 4.75 < 5.25 VOLTS DC REG. @ 500 MA
 -12 V = -10.0 > -14.0 VOLTS DC REG. @ 10 MA

TIMING DIAGRAM

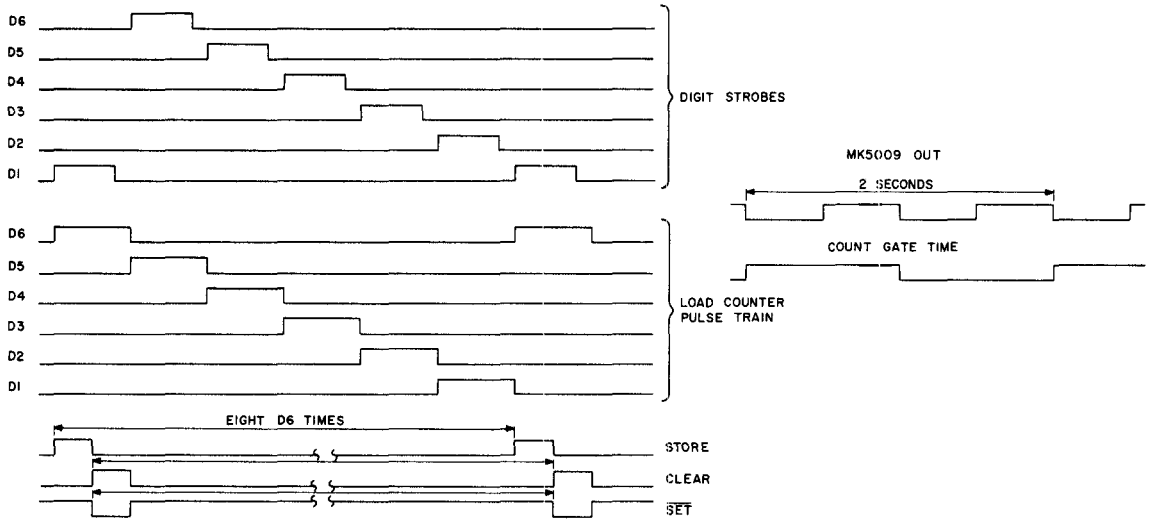

The SN7490 is advanced one count at the digit six time at the start of the sequence.

Latch Digit Four Data,
Load Into Counter Digit Six

Latch Digit Three Data,
Load Into Counter Digit Five

Latch Digit Two Data,
Load Into Counter Digit Four

Latch Digit One Data,
Load Into Counter Digit Three

At this time, the output of the SN7490 is decoded to select via the SN74153's first digit two data, then digit one data is selected which at the end of sample time was stored in the SN74196 and SN74S196. So the sequence is continued.

Latch Digit Two Data
Load Into Counter Digit Two

Latch Digit One Data
Load Into Counter Digit One

At the beginning of the eight count of the SN7490 several things take place. The MK 50395 is furnished with a store pulse to display the shifted data. A clear is applied to the MK 50395 to ready it for a new cycle.

The divide-by-two action of the first $\frac{1}{2}$ SN7474 allows the second clear clock to have no effect at the second clear pulse. The SN74S196 and SN74196 are cleared. The second $\frac{1}{2}$ SN7474 is preset which disables the load counter SN74151. The SN7490 is reset to zero.

To improve front end sensitivity, a suitable wide-band amplifier may be used. A typical device would

be a μ A 733. Timing diagrams for the MK 50395 and the associated circuitry are provided to further describe the various functions.

DARKROOM TIMER - A TYPICAL APPLICATION

A darkroom timer capable of being set for time periods from 99 minutes and 59 seconds is illustrated. The time interval to be set is entered into the BCD thumbwheel switches. Upon pressing the start button, the time indicated on the thumbwheel switches causes the counter to be loaded identically. Diode CR1 loads the register for a prewarning signal (8 seconds in diagram) prior to the end of the time interval so the operator can be alerted to the fact that the time interval is about over.

Resistor network R1, R2 lowers the 60Hz line voltage so that the positive peak does not exceed Vss. Otherwise, damage to the circuit could occur. The counter input is driven directly from the 60 Hz line frequency and the two LSD's are not monitored by the display since they perform a divide function in this application. The LED display will present the time remaining, since the counter is in the count down mode. If an illegal entry is made, such as binary 12, (1100), the display will show "E" in the digits containing an illegal entry. The counter will eventually "count out" the "E", but, of course, the time interval will not be useful. Also, it is possible to load illegal time such as 75 seconds. This illegal time will result in an error in timing.

Sequence of Events

Assume a time interval of 1 minute, 45 seconds has been selected and programmed into the thumbwheel switches.

- Pressing the start button completes loading 1 minute 45 seconds into the counter. The register is loaded with the eight-second prewarning signal. The relay is activated, which allows the count down sequence to begin. (The display will imme-

DARK ROOM TIMER

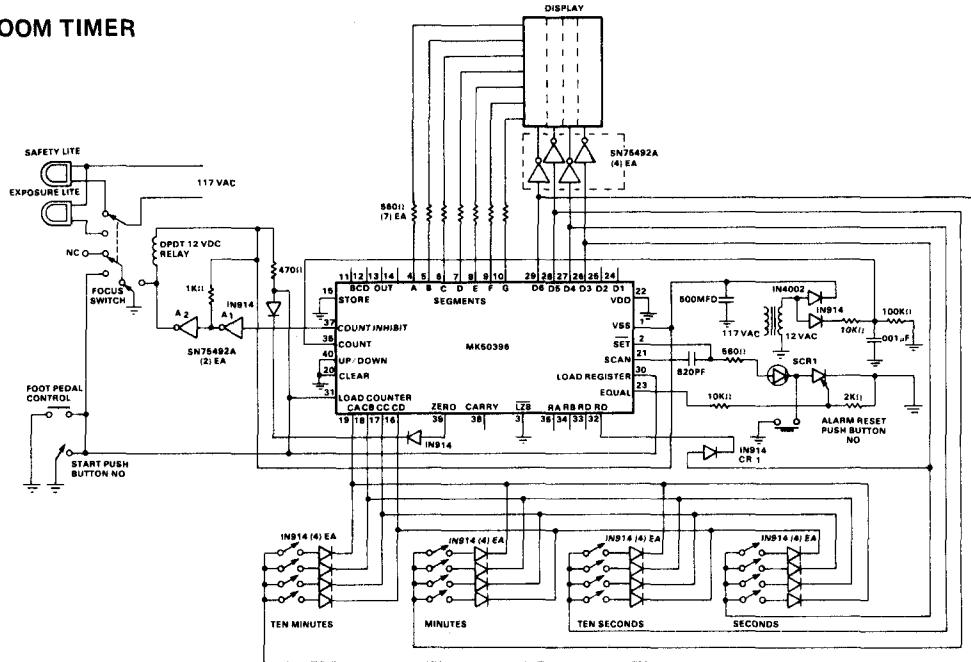

diately show 1:44, because the — 60 stage will be counting down the 60Hz input.) The relay also turns off the safety light and turns on the exposure light.

- When eight seconds to time-out occurs, the equal output goes to V_{SS} momentarily, turning on SCR1, which lights an LED warning light that indicates the time interval is about over.
- When the counter hits zero time, the zero output inhibits any further count input. The zero output also provides bias to turn on amplifier A1 to turn off relay driver amplifier A2, so the safety light will come on as the exposure light turns off.
- The reset switch is used to turn off the SCR for the next time sequence.

DIGITAL TUNING INDICATOR

The MK 50395 is used to count and display frequencies of the FM frequency bands.

The frequency being sampled is buffered to TTL logic levels, then divided by 100 with an SN74S112 JK flip-flop, an SN74S196 and an SN7490. Transistor Q1 then shifts the TTL logic levels to MOS logic levels.

The CMOS RC time base is adjusted to oscillate at 1kHz and is then divided by two to produce the necessary 500Hz time base.

At the end of the count sample time, a store is generated to latch the data into the display.

The placement of the diodes which determine the value to be loaded in the MK 50395 counter is dependent on the frequency of the local oscillator

and whether high-side or low-side injection is used in the receiver.

In a typical FM receiver with High-side injection, a dial setting of 88.7 MHz means the local oscillator output would be 99.4MHz. To offset the 10.7MHz (88.7 + 10.7), the counter would be preloaded to 999893 (000000 minus 107). This effectively subtracts the 10.7MHz thus displaying the dial frequency. After each sample time, the MK 50395 counter is reloaded, readying it for the next count cycle. For low-side injection receivers, the preset would be 107 (00000 plus 107). This effectively adds 10.7MHz to the count. The decimal point of Digit two may be wired to +V through a resistor to produce the decimal in the FM mode.

To calibrate the time base, an oscilloscope or frequency counter may be used. However, careful adjustment at the low and high end of the counter display would be sufficient.

N PULSER

The N Pulser was designed to gate a specific number of pulses. Its design uses a minimum of external circuitry.

The number of pulses to be gated are entered into the thumbwheel switches. This value is loaded into the BCD Register with the LOAD button. When the MK 50395 counter reaches this value, the MK 50395 EQUAL output goes high. The pulse string is then interrupted.

To control frequencies above 500kHz, a suitable prescaler could be used at the MK 50395 count input, and compensated by the value entered into

V
COUNTER
DISPLAY
DECODERS

DIGITAL TUNING INDICATOR

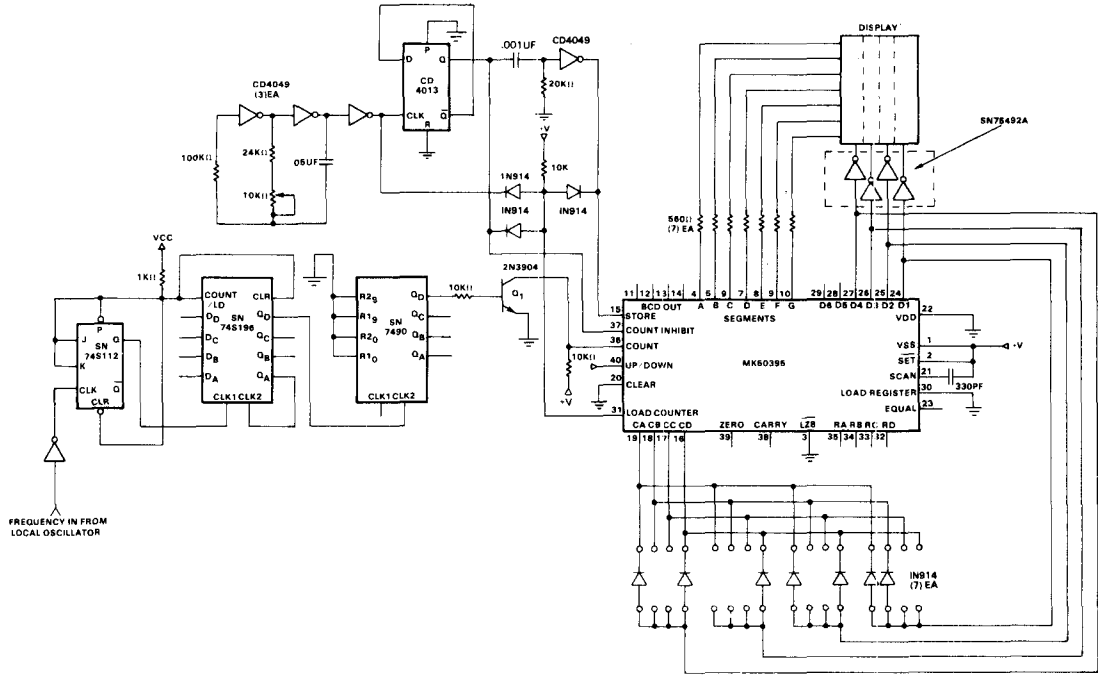

the MK50395 BCD Register. Pulses in and pulses out must be CMOS compatible, or suitable level shifters will be required.

CONTINUOUS RATE-INDICATING THERMOMETER
The MK50395 displays the result of a program of eight periods (P0 through P7) under control of a

N PULSER

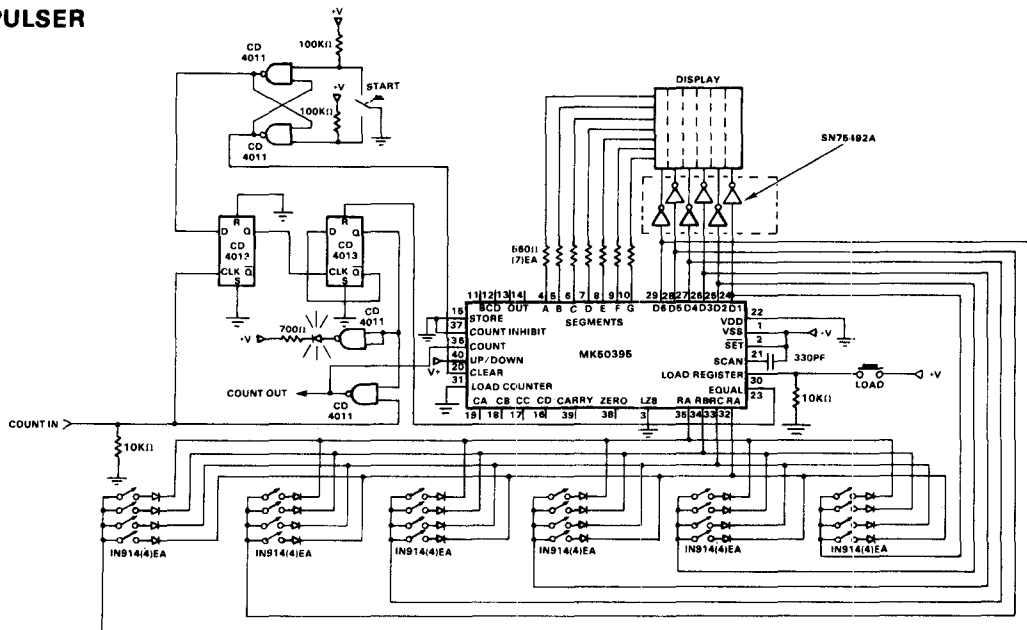

RATE INDICATING THERMOMETER

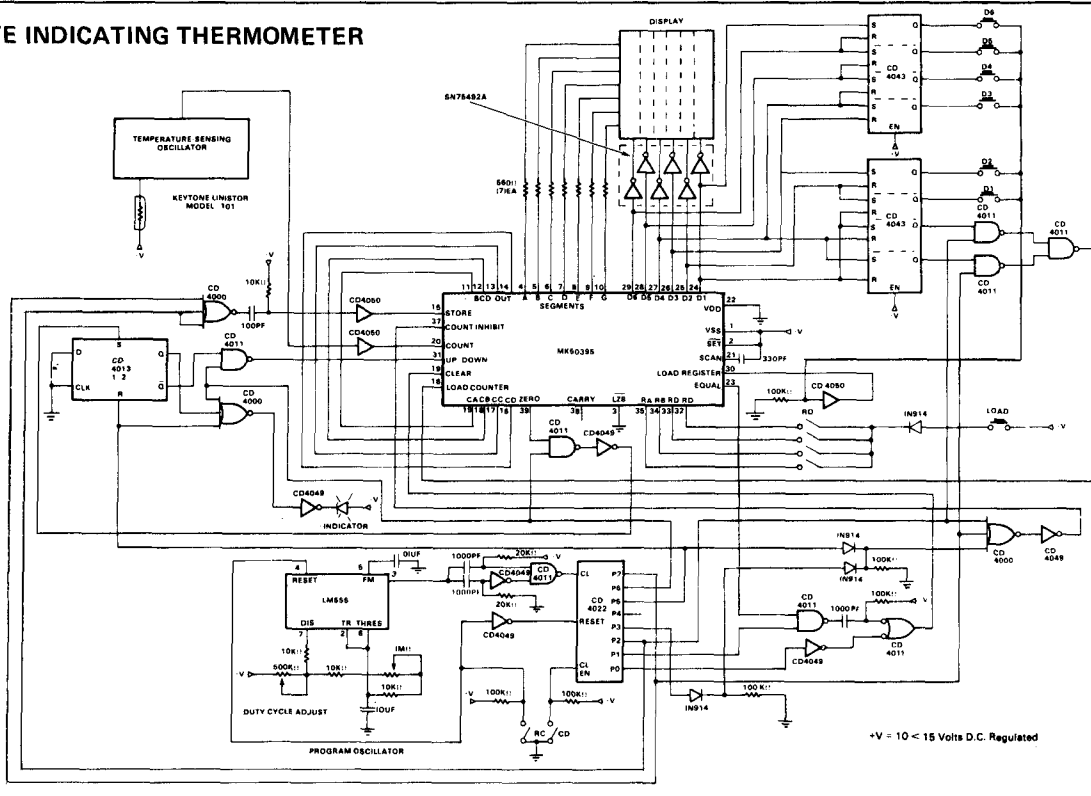

program counter (CD4022) which is driven by a program oscillator having independent controls for its frequency and its duty cycle. The output of the program oscillator is differentiated to supply a clock pulse to the program counter for each half cycle of the program oscillator. The program counter has eight decoded outputs which are used to time the program periods P0 through P7.

A voltage-controlled oscillator in conjunction with a thermistor converts temperature into frequency. After the initial calibration, it is desirable that the VCO be stable to maintain accuracy of temperature change indications, which occur during P4 and P6 times.

During P0, the P0 output of the program counter is high and the counter of the MK 50395 is reset. During P1, the MK 50395 counter is incremented at the rate of the pulses furnished by the temperature-sensitive oscillator. When the counter reaches equality with the register, the counter is reset to zero and continues counting until the end of P1.

The length of the positive-going half-cycles of the program oscillator (during P1, P3, P5 and P7) is selected so that during the period P1, the number of cycles of the temperature-sensitive oscillator (which are counted) changes with temperature at the rate of one thousand cycles per degree (either F or C). For example, if the frequency of the temperature-sensitive oscillator is 75kHz at 70°F and changes at the rate of 1000 Hz per degree change of temperature, the positive-going half-cycle of the program oscillator is selected to equal 1.0 second

vary the count of the 50395 counter (at the end of P1) by 1000 counts per degree. The register is preloaded with a quantity to calibrate temperature. In the above example, the register is preloaded with the quantity 80,000 so that the counter stands at 70,000 (150,000-80,000) at the end of P1 indicating a temperature of 70°F. Only the three most significant digits of the MK 50395 counter are displayed for temperature, and the display indicates the temperature in degrees, 70, 71, etc. The leading zero is blanked.

The three most significant digits of the counter indication are set into the MK 50395 latch during P2, but not before the three least significant digits of the counter are loaded to a quantity equal to that stored in the three least significant digits stored in the latch. These counter digits are set by bringing the load counter pin 31 high at the end of digit 4 thru digit 1 time and then bringing the store pin 15 low after the leading edge of D3, D2, and D1 with a delay. The four BCD output pins 11-14 are connected directly to the four counter inputs, pins 16-19. In this way the three least significant digits are retained in the latch and the three most significant digits of the latch are set to the current temperature. The three least significant digits in the latch store the current rate of change of temperature which is calculated during subsequent periods of the program.

During P3, the MK 50395 counter is reset.

During P4, the MK 50395 counter is again ready to

V
COUNTER
DISPLAY
DECODERS

THERMOMETER TIMING

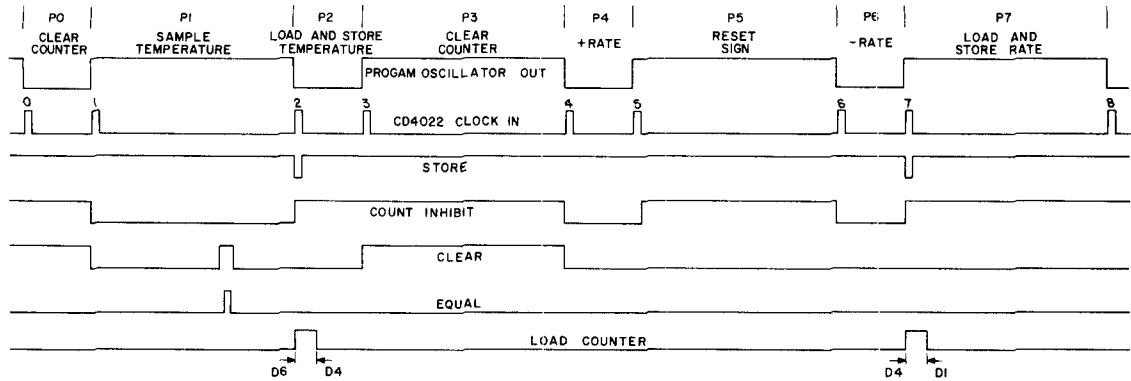

count the pulses produced by the temperature-sensing oscillator for an entire period, during which the content of the register is ignored.

During P5, the sign flip-flop is reset so that the MK 50395 counter counts down during the following period. During P6, the MK 50395 is again ready to count up the temperature sensitive oscillator for one half cycle, and count down from the state arrived at at the end of P4. If the temperature has not changed in the interval between P4 and P6, the MK 50395 counter will stand at zero at the end of P6. If the temperature has decreased since P4, the counter will stand at some number which is proportional to the rate of change in temperature.

If the temperature has increased between P4 and P6, the MK 50395 counter is counted down to zero before the end of P6. When this occurs the sign flip-flop is set, and the level at pin 40 goes high, changing the mode of counting from down to up. At the end of P6, the MK 50395 counter stores a quantity which is proportional to the rate of change of temperature. If the sign flip-flop remains reset after P6, it provides a signal to the negative sign display associated with the rate display.

The durations of the periods of the negative-going half-cycle of the program oscillator are chosen so that the rate identifying contents of the MK 50395 counter are in units of degrees-per-hour. Since the change of temperature is less than 1000 per hour, only the lowest three digits of the counter contain significant information, with the three higher orders standing at zero. During P7, the current temperature data from the three highest digits of the latch are set into the counter by bringing the load counter pin 31 high from the leading edge of D1 thru D4. The contents of the counter are then stored in the latch by bringing pin 15 up after a delay. The program counter is reset to zero at P0 and the entire program is repeated successively. Display of tem-

perature and rate of change is continuous, with the negative sign blanked during P5 and P6.

The temperature calibration data is entered into the register by operation of several manual switches. The CD4043 latches allow the digits of the BCD Register to be loaded individually and not alter the data in other digits.

Switches CD and RC are provided for disabling the program counter and for resetting the program counter (and the program oscillator.)

To load the BCD register, close the reset counter (CD) switch, select the desired BCD data with the register data switches, then depress the desired digit switch and the load data switch at the same time. After all digits have been properly loaded, check operation to assure the proper data has been loaded.

The period of the positive-going half-cycle of the program oscillator is chosen to allow calibration of the temperature. The period of the negative-going half-cycle of the program oscillator (P0, P2, P4, and P6) is chosen independently of the positive-going half-cycle to allow calibration of the rate of change.

Where the period of the positive-going half-cycle is P (in seconds), the period of the negative-going half-cycle is chosen equal to $\frac{p^2}{3.6 \cdot P}$ or the frequency

of the program oscillator is chosen equal to $\frac{3.6 \cdot P}{3.6 \cdot P}$

This allows calibration for both temperature and rate of change without any restriction on the temperature-sensitive oscillator.

The timing diagram above indicates the relative contents of the MK 50395 counter during the eight program periods.