



MEZS7-1SSAPowerBank

All-In-One 3A Battery Charger with 3A Boost Current Solution Module

DESCRIPTION

The MEZS7-1SSAPowerBank is a complete power bank solution module using the MP2632, which includes a buck charger with BC1.2 detection, integrated boost with two separate outputs, and a 4-LED indicator for battery state of charge.

The solution module uses a form-fitting board and supports two operating modes — charge mode and boost mode — to allow management of the system and battery power based on the state of the input.

When a 5V USB input power is present, the board charges a single-cell battery with a max charge current of 3A. In the absence of an input source, the solution module switches to boost mode through the PB pin to power the USB type-A output from the battery with up to 3A of current.

The solution module provides four LED drivers to achieve the voltage based fuel gauge indication and distinguish charge mode from boost mode.

To guarantee safe operation, the solution module offers input over-voltage protection, battery over-voltage protection, thermal shutdown, battery temperature monitoring, and a timer to prevent prolonged charging of a dead battery.

ELECTRICAL SPECIFICATIONS

Parameter	Symbol	Value	Units
Charge Mode			
Input voltage range	V_{IN}	4.55 to 6	V
Charge-full voltage	V_{BATT_FULL}	4.2, 4.35, 4.45	V
Charge current	I_{CHG}	3	A
Input current limit	I_{IN_LIM}	2.7	A
Boost Mode			
Battery voltage	V_{BATT}	3 to 4.45	V
SYS voltage regulation	V_{SYS}	5	V
SYS output current limit	I_{SYS}	3	A

FEATURES

- 4.55V to 6V Operating Input Voltage Range
- Power Management Function Includes Integrated Input Current Limit and Input Voltage Regulation
- Up to 3A Charge Current
- Selectable 4.45V, 4.35V, or 4.2V Charge Voltage with 0.5% Accuracy
- Battery Temperature Monitoring
- 4 LED Drivers for Battery Fuel Gauge Indication
- Timer Backup Protection
- Battery Reverse Leakage Blocking
- Reverse Boost Operation for Powering the System
- Up to 94% 5V Boost Mode Efficiency at 3A with BATT = 4.5V
- Up to 3A Output Current Limit in Boost Mode

APPLICATIONS

- Battery Backup Applications
- Power Bank Applications for Smartphones, Tablets, and Other Portable Devices

All MPS parts are lead-free, halogen free, and adhere to the RoHS directive. For MPS green status, please visit the MPS website under Quality Assurance. "MPS", the MPS logo, and "Simple, Easy Solutions" are Registered Trademarks of Monolithic Power Systems, Inc. or its subsidiaries.

MEZS7-1SSAPOWERBANK SOLUTION MODULE

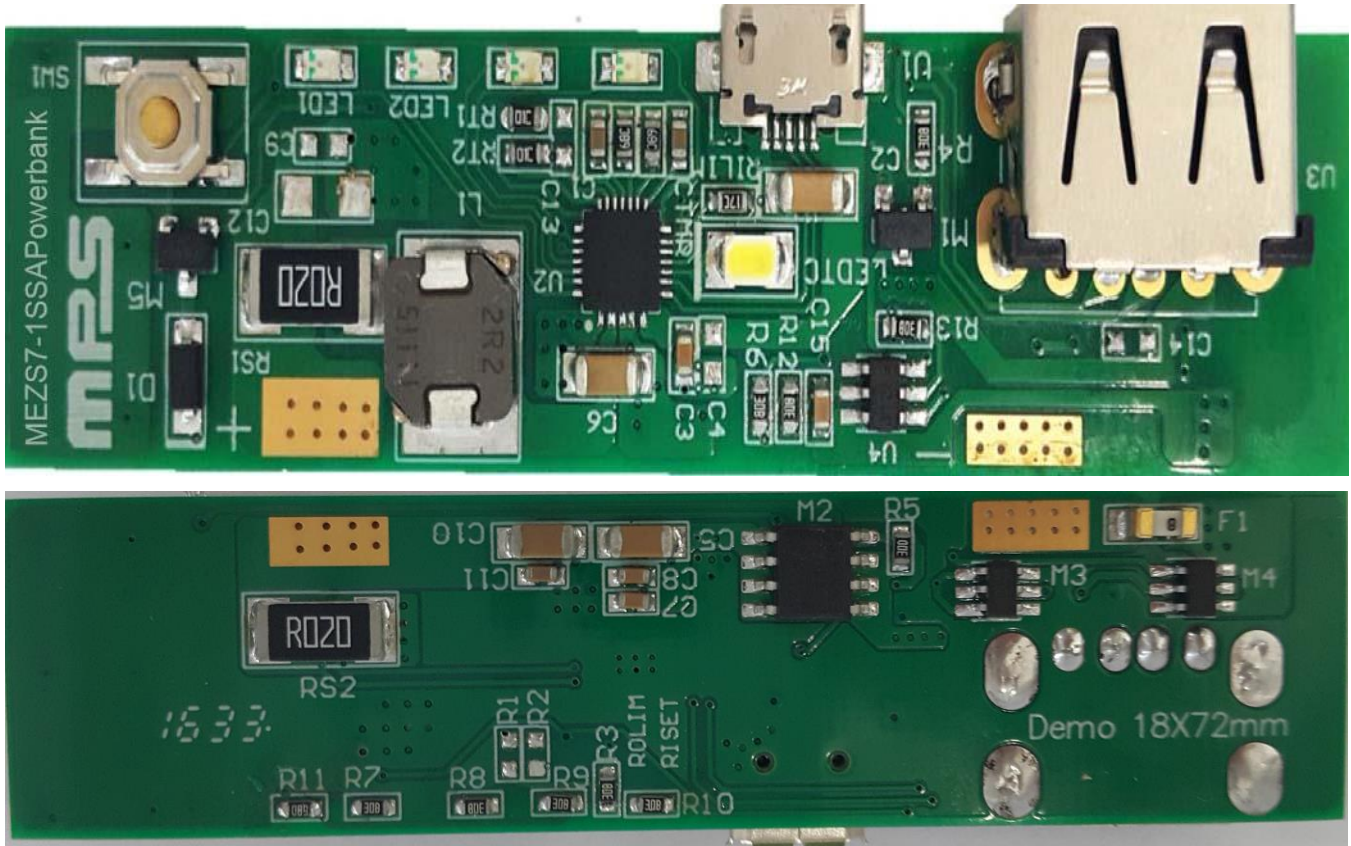

(LxWxH) 7.16cmx1.8cmx0.16cm

Board Number	MPS IC Number
MEZS7-1SSAPowerBank	MP2632GR

QUICK START GUIDE

This solution module supports the MP2632, a standalone switch-mode battery charge management and system power path management device with integrated reverse directional boost from BATT to SYS. The solution module's layout accommodates most commonly used capacitors. The default function of this solution module is preset at charge mode; the charge-full voltage is preset to 4.2V for a single-cell Li-ion battery.

Charge Mode Setting

1. Input Current Limit

An input current limit can be set slightly below the input source's maximum current rating. When the input current reaches this limit, the charge current decreases to keep the input current constant at the limit value to initially power the system. The resistor connected to the ILIM pin (R_{ILIM}) programs this limit. To set the input current limit at 2.7A, set R_{ILIM} at 14.7k Ω . I_{ILIM} can be calculated using Equation (1):

$$I_{ILIM}(A) = \frac{40(k\Omega)}{R_{ILIM}(k\Omega)} \quad (1)$$

2. Charge-Full Voltage

The default charge-full voltage on this solution module is set at 4.2V by floating R1 and R2. The setting can be modified according to Table 1.

Table 1: R1 and R2 Settings

R1	R2	Charge-Full Voltage (V)
Float	Float	4.2
Float	0 Ω	4.35
0 Ω	Float	4.45

3. Charge Current

The charge current can be programmed via both RS1 and R_{ISET} . With given RS1 = 10m Ω , determine the charge current using Equation (2):

$$I_{CHG}(A) = \frac{1500}{R_{ISET}(k\Omega) \times RS1(m\Omega)} \quad (2)$$

For a 3A charge current, the given R_{ISET} is 49.9k Ω .

Boost Mode

1. System Output Current Limit

Set the system output current limit in boost mode for the MP2632 to operate like a standard adapter. Set the output current limit using Equation (3):

$$I_{OLIM}(A) = \frac{1500}{R_{OLIM}(k\Omega) \times RS1(m\Omega)} \quad (3)$$

For a 3A output current limit, the given R_{OLIM} is 49.9k Ω .

For additional information on MP2632 operation, refer to the MP2632 datasheet.

EQUIPMENT REQUIREMENTS

Evaluation requires the following equipment:

1. A USB cable with an adapter or any USB port with load capability (for the charge input) can be used for the solution module. If a certain operation state cannot be tested, an external wire can be added to connect a power source with 6V/3A capability.
2. A battery simulator or a single-cell battery pack. The battery simulator's output rating should be greater than 4.5V/7.0A. When using a real battery pack, review all precautions in the battery manufacturer's datasheet and ensure the charger's setting do not exceed the battery's absolute maximum specifications.
3. An e-load or real smartphone. The e-load capability should be greater than 5V/3A.
4. An oscilloscope with a single voltage probe and a single current probe.
5. An multi-meter.

Charge Function

1. Attach the positive and negative ends of the battery to the "+" and "-" terminals, respectively. If using a battery simulator, preset the voltage to 3.8V (typical value) first.
2. Use the USB cable and adapter or any USB port with load capability.

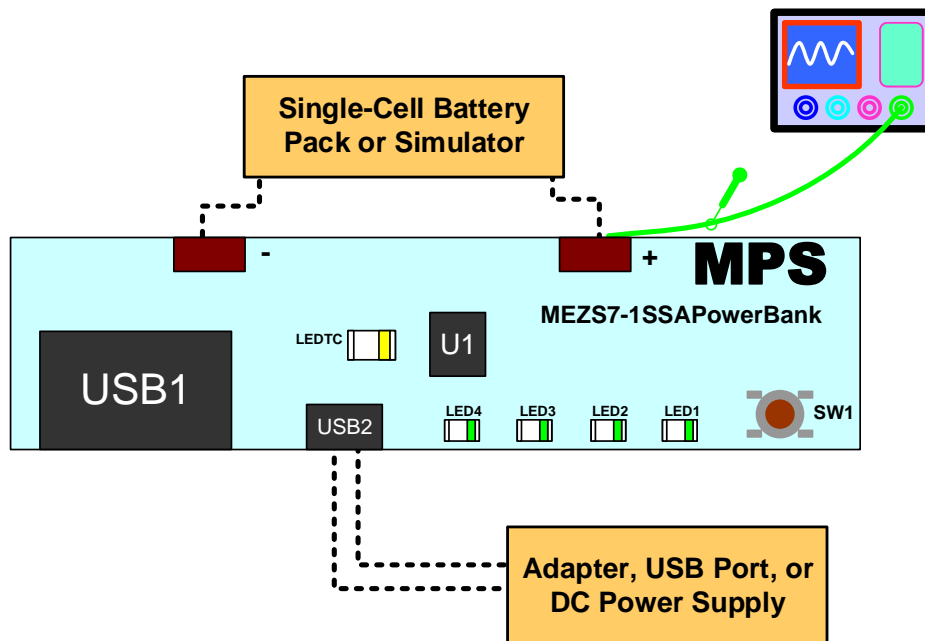

Figure 1: Set-Up for Charge Mode

3. Connect the adapter or USB port to the solution module through USB2 to start the charge. Use the oscilloscope to verify a 3A charge current is being delivered to the battery. The charge current can be a different value than 3A under the following conditions:
 - a. The charge current is limited by the input current limit.

The IC features input source detection to decide the input current limit according to the input source (USB or adapter). The IC sets the input current limit using Table 2 once the DP1/DM1 detection is complete.

Table 2: Input Current Limit Setting

DP1/DM 1 Detection	I _{IN_LMT}
Floating	500mA
SDP	500mA
CDP or DCP	Set through R _{ILIM}

b. The charge current is limited by the input voltage regulation.

Once the input voltage approaches the input voltage regulation threshold (internally preset at 4.65V), the charge current is reduced to allow priority of the system power and maintain proper regulation of the input voltage. This occurs when the input power source does not have enough capability or the voltage loss on the USB cable is too large.

4. If certain operation states cannot be tested, an external wire can be added to connect a power source. Short DP1 and DM1 to set the DP1/DM1 detection as SDP; the input current limit is 500mA.
5. Connect USB1 to the e-load or real smartphone. Most charge mode functions can be tested once these connections are made.

a. Input current limit

When the DC power supply has a greater current capability than the input current limit, increase the load current of the e-load. When the input current reaches this limit, the charge current decreases to keep the input current constant at the limit value.

b. Input voltage regulation

When the DC power supply has a smaller current capability than the input current limit, increase the load current of the e-load. The input power source may be insufficient to support both the charge current and system load current; this will cause the input voltage to drop. Once the voltage drops to V_{IN_REG}, the charge current reduces to allow priority of the system power and keep the input voltage from dropping further.

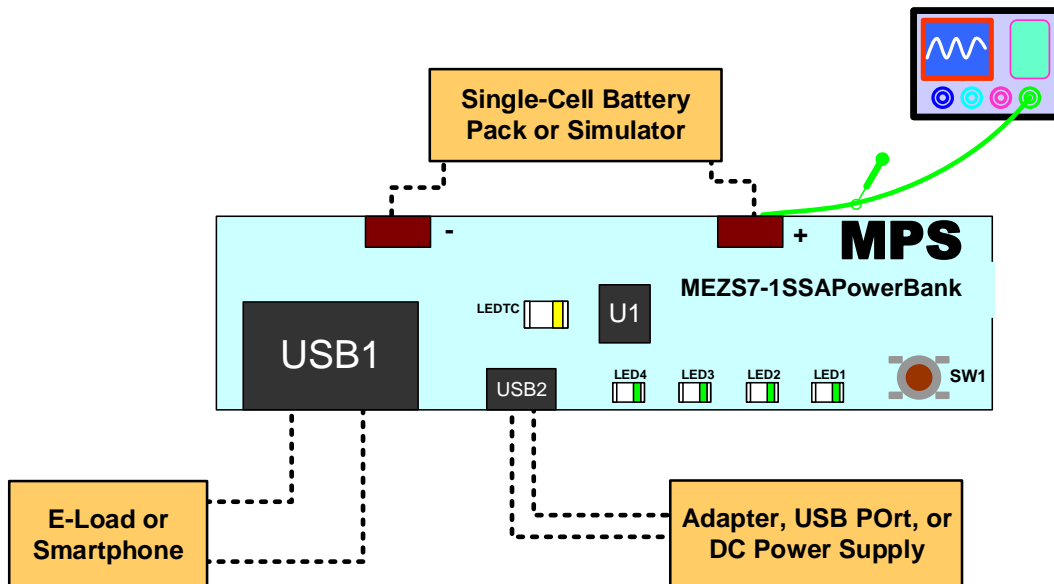
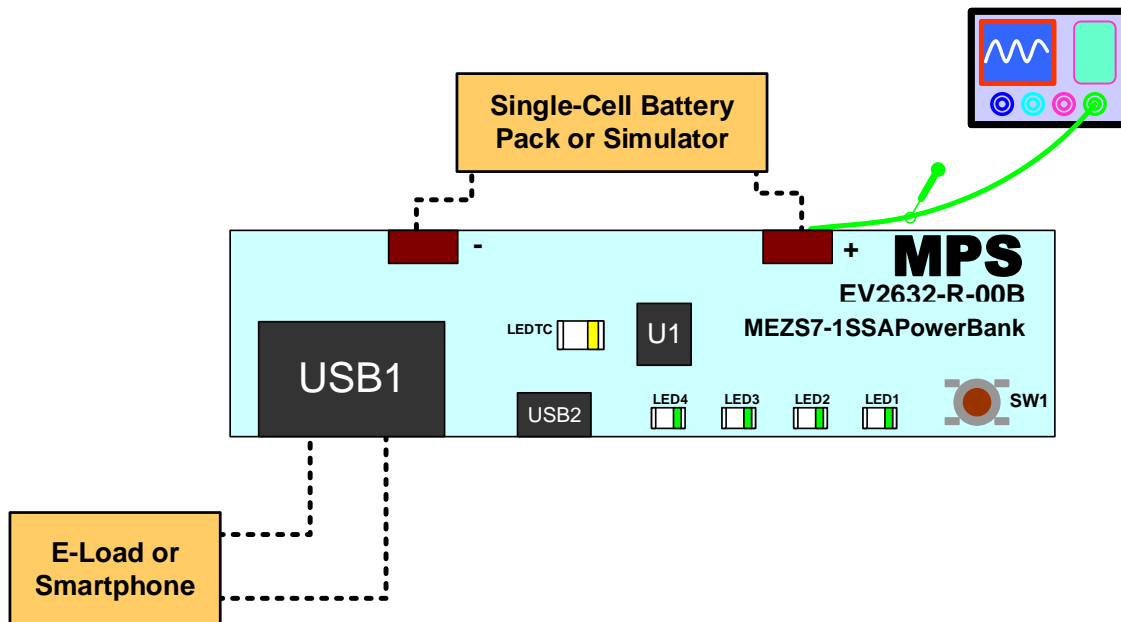

Figure 2: Set-Up for Charge Mode with System Load

Boost Function

1. Connect the e-load or real smartphone to SYS USB1 on the solution module.
2. Attach the positive and negative ends of the battery to the “+” and “-” terminals, respectively. If using a battery simulator, preset the voltage to 3.8V (typical value) first.
3. Ensure the battery protection chip is enabled. If the chip is in sleep mode, the following steps are required:
 - a. Connect USB2 with a 5V input source so the IC works in charge mode to enable the battery protection chip.
 - b. Remove V_{IN} from USB2.
4. Short push SW1 from high to low for more than 1.5ms; the boost should start to work. Verify the system output current is limited at 3A.
5. Long push SW1 from high to low for more than 2.5s; the boost operation should shut down.
6. Double-click SW1 to turn LEDTC on or off.
7. Once the voltage between the “+” and “-” terminals drops below the over-discharge voltage, the battery protection chip operates in sleep mode. Boost operation cannot be enabled until the battery pack charge exceeds the over-discharge voltage. If a battery simulator is used for the test, only ramping up the battery simulator voltage will not enable the battery protection chip from sleep mode. Step 3 is still required.

Figure 3: Set-Up for Boost Mode

8. Remove the load from USB1; the boost operation will terminate after 16s.
9. Connect a smartphone to USB1 when the MP2632 is in sleep mode; this enables boost operation.

SOLUTION MODULE SCHEMATIC

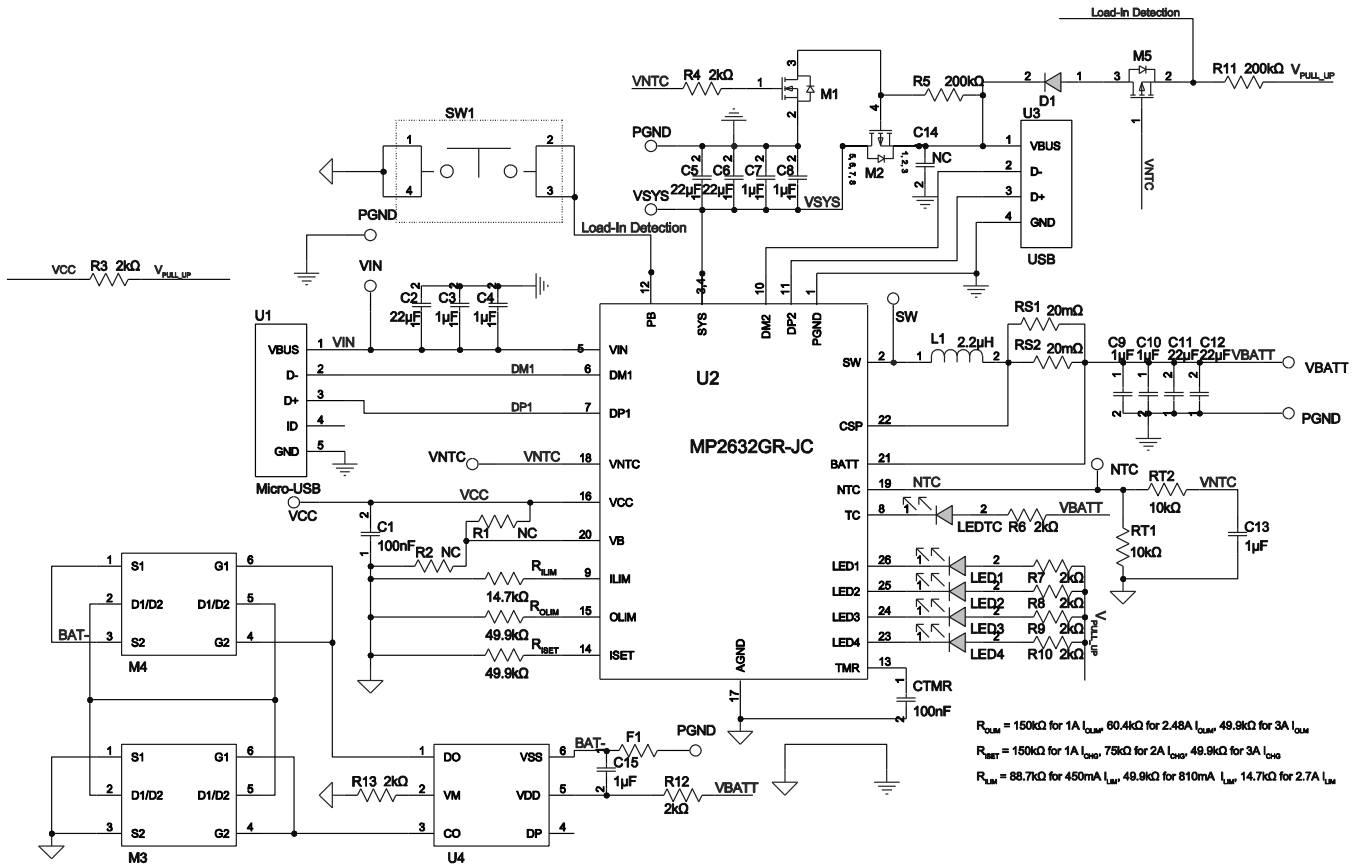

Figure 4: Solution Module Schematic

MEZS7-1SSAPOWERBANK BILL OF MATERIALS

Qty	Ref	Value	Description	Package	Manufacturer	Manufacturer PN
1	D1	B130LAW	Schottky diode, 30V, 1A	SOD-123	Diodes	B130LAW-7-F
2	RS1, RS2	20mΩ	Resistor, 1%	2512	Yageo	RL2512FK-070R02L
2	RIS1, ROLIM	49.9kΩ	Film resistor, 1%	0603	Yageo	RC0603FR-0749K9L
2	R1, R2	NC	Film resistor, 5%	0603		
1	RILIM	14.7kΩ	Film resistor, 1%	0603	Yageo	RC0603FR-0714K7L
2	RT1, RT2	10kΩ	Film resistor, 1%	0603	Yageo	RC0603FR-0710KL
1	R5	200kΩ	Film resistor, 1%	0603	Yageo	RC0603FR-07200KL
1	R11	54.9kΩ	Film resistor, 1%	0603	Yageo	RC0603FR-0754K9L
9	R3, R4, R6, R7, R8, R9, R10, R12, R13	2kΩ	Film resistor, 1%	0603	LIZ	CR0603JA0202G
4	C4, C9, C13, C14	NC	Ceramic capacitor	0603		
1	C12	NC	Ceramic capacitor	1206		
1	C15	1μF	Ceramic capacitor, 16V, X7R, 0603	0603	Murata	GRM188R71C105KA12D
4	C2, C5, C6, C10	22μF	Ceramic capacitor, 25V, X5R	1206	Murata	GRM31CR61E226KE15
4	C3, C7, C8, C11	1μF	Ceramic capacitor, 25V, X7R	0603	TDK	C1608X7R1E105K
2	C1, CTMR	100nF	Ceramic capacitor, 16V, X7R, 0603	0603	TDK	C1608X7R1C104K
1	LEDTC	3020White	White LED, 3.2V to 3.4V, 30mA	3020	Any	
4	LED1, LED2, LED3, LED4	BL-HGB35A-TRB	Green LED	0805	Bright LED	BL-HGB35A-TRB
1	L1	2.2μH	Inductor, 2.2μH, 0.173mΩ, 8.2A	SMD	TDK	SPM6530T-2R2M
1	M1	AM2336N	N-channel MOSFET, 30V, -5A, 32mΩ	SOT-23	Analog Power	AM2336N
1	M2	AM4825P-T1	P-channel MOSFET, -30V, -9.3A, 19mΩ	SO-8	Analog Power	AM4825-T1-PF
2	M3, M4	8205A	Dual N-channel MOSFET (20V, 6A)	TSSOP-8L	Any	8205A
1	M5	AM2305PE-T1	P-channel MOSFET, -20V, -4.5A, 43mΩ	SOT-23	Analog Power	AM2305PE-T1
1	U1	629105136821	Micro-B USB receptacle		Wurth	629105136821
1	U2	MP2632	Switching charger	QFN-26 (4mmx4mm)	MPS	MP2632GR
1	U3	USB	Type-A USB receptacle		Any	
1	U4	FS312F-P	Battery protection	SOT-23-6	Fortune	FS312F-P
1	SW1	Push switching button	Button, SM 4mmx10mm, 1.5mm height		Any	
1	F1	0458008	63VDC, 8A fuse	1206	Littelfuse	0458008

PCB LAYOUT

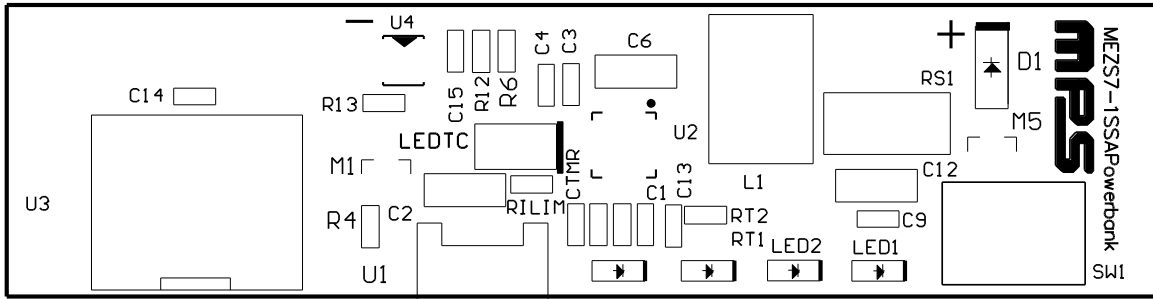

Figure 5: Top Silk

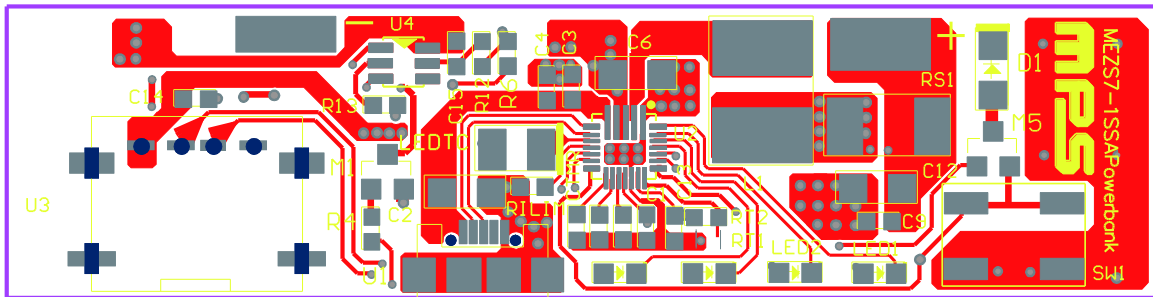

Figure 6: Top Layer

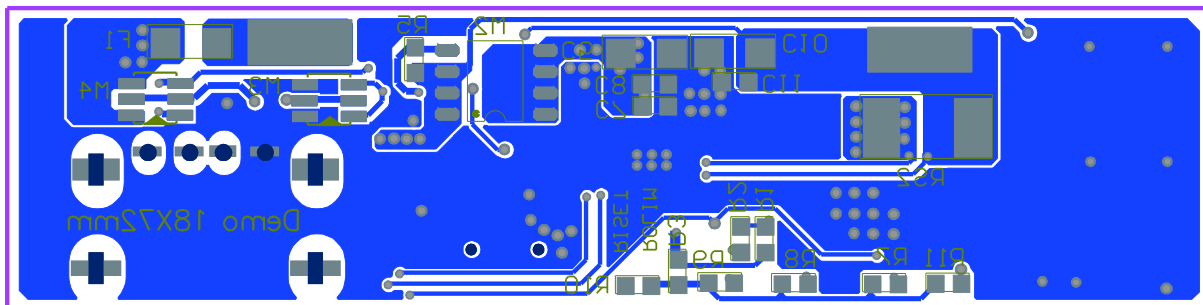

Figure 7: Bottom Layer

Revision History

Revision #	Revision Date	Description	Pages Updated
1.0	6/23/2020	Initial Release	-

Notice: The information in this document is subject to change without notice. Users should warrant and guarantee that third-party Intellectual Property rights are not infringed upon when integrating MPS products into any application. MPS will not assume any legal responsibility for any said applications.