

### ■ Features

- SIP7 package with international standard pinout
- Operating temperature range -40 ~ +85°C
- Medical safety approved (1xMOPP/2xMOOP) according to ANSI/AAMI ES60601-1
- Low patient leakage current <2μA
- Protection: Short circuit(3 second max.)
- 6KVDC or 4.2VAC high I/O isolation (Reinforced isolation)
- Low cost
- 3 years warranty

### ■ Applications

- Medical devices
- Medical oxygen monitor
- CT scanning
- Medical carts
- Oral care equipment

### ■ Description

MDS02 and MDD02 series are 2W isolated and unregulated module type medical grade DC-DC converter with SIP7 package. It features international standard pins, a high efficiency up to 85%, wide working temperature range -40~+85°C, 6KVDC or 4.2KVAC I/P-O/P high isolation voltage, short circuit protection, etc. The models account for different input voltage 5V/12V/24V±10%, and various output voltage, 5V/12V/15V for single output and ±5V/±9V/±12V/±15V for dual outputs, which are suitable for medical systems, ultra low leakage current.

### ■ Model Encoding

**MD****S****02****L** - **12**

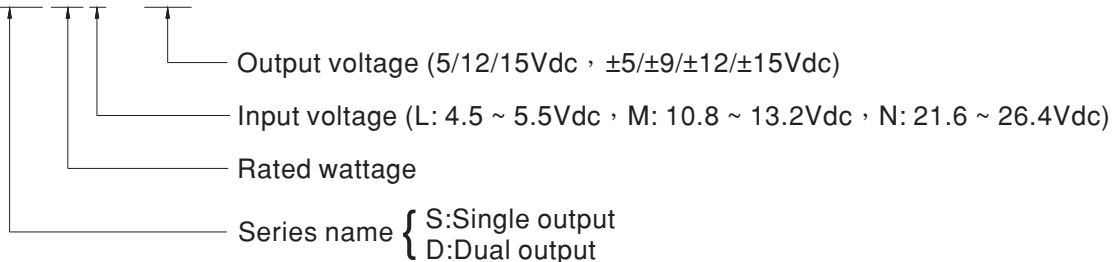



MODEL SELECTION TABLE							
ORDER NO.	INPUT			OUTPUT		EFFICIENCY (TYP.)	CAPACITOR LOAD (MAX.)
	INPUT VOLTAGE (RANGE)	INPUT CURRENT		OUTPUT VOLTAGE	OUTPUT CURRENT		
		NO LOAD	FULL LOAD				
MDS02L-05	Normal 5V (4.5 ~ 5.5V)	35mA	510mA	5V	40 ~ 400mA	77%	1000μF
MDS02L-12		47mA	510mA	12V	17 ~ 167mA	80%	470μF
MDS02L-15		65mA	510mA	15V	13 ~ 133mA	79%	470μF
MDD02L-05		35mA	500mA	±5V	±20 ~ 200mA	78%	*470μF
MDD02L-09		47mA	500mA	±9V	±12 ~ 111mA	81%	*470μF
MDD02L-12		60mA	510mA	±12V	±9 ~ 83mA	78%	*220μF
MDD02L-15		65mA	510mA	±15V	±7 ~ 67mA	79%	*220μF
MDS02M-05	Normal 12V (10.8 ~ 13.2V)	15mA	215mA	5V	40 ~ 400mA	75%	1000μF
MDS02M-12		16mA	205mA	12V	17 ~ 167mA	83%	470μF
MDS02M-15		17mA	200mA	15V	13 ~ 133mA	84%	470μF
MDD02M-05		17mA	210mA	±5V	±20 ~ 200mA	78%	*470μF
MDD02M-09		21mA	205mA	±9V	±12 ~ 111mA	83%	*470μF
MDD02M-12		18mA	205mA	±12V	±9 ~ 83mA	83%	*220μF
MDD02M-15		24mA	205mA	±15V	±7 ~ 67mA	82%	*220μF
MDS02N-05	Normal 24V (21.6 ~ 26.4V)	8mA	106mA	5V	40 ~ 400mA	80%	1000μF
MDS02N-12		9mA	103mA	12V	17 ~ 167mA	83%	470μF
MDS02N-15		9mA	100mA	15V	13 ~ 133mA	85%	470μF
MDD02N-05		11mA	106mA	±5V	±20 ~ 200mA	77%	*470μF
MDD02N-09		11mA	103mA	±9V	±12 ~ 111mA	83%	*470μF
MDD02N-12		11mA	103mA	±12V	±9 ~ 83mA	82%	*220μF
MDD02N-15		12mA	103mA	±15V	±7 ~ 67mA	82%	*220μF

\* For each output



SPECIFICATION				
INPUT	VOLTAGE RANGE	L: 4.5 ~ 5.5Vdc M: 10.8 ~ 13.2Vdc N: 21.6 ~ 26.4Vdc		
	SURGE VOLTAGE (100ms max.)	5Vin models : 9Vdc 12Vin models : 18Vdc 24Vin models : 30Vdc		
	FILTER	Internal capacitor		
	PROTECTION	Fuse recommended. 500mA Slow-Blow Type for all models		
OUTPUT	VOLTAGE ACCURACY	±5.0%		
	RATED POWER	2W		
	RIPPLE & NOISE <small>Note.2</small>	75mVp-p		
	LINE REGULATION <small>Note.3</small>	1.2% for 1% input variation		
	LOAD REGULATION <small>Note.4</small>	±10%		
	SWITCHING FREQUENCY (Typ.)	100KHz		
PROTECTION	SHORT CIRCUIT	3 second max.		
ENVIRONMENT	COOLING	Free-air convection		
	WORKING TEMP.	-40 ~ +85°C (Refer to "Derating Curve")		
	WORKING HUMIDITY	20% ~ 90% RH non-condensing		
	STORAGE TEMP., HUMIDITY	-55 ~ +125°C, 10 ~ 95% RH non-condensing		
	TEMP. COEFFICIENT	0.02% / °C (0 ~ 85°C)		
	SOLDERING TEMPERATURE	1.5mm from case of 1 ~ 3sec./260°C max.		
	VIBRATION	10 ~ 500Hz, 2G 10min./1cycle, period for 60min. each along X, Y, Z axes		
SAFETY & EMC <small>(Note.6)</small>	WITHSTAND VOLTAGE	I/P-O/P:6KVDC or 4.2KVAC		
	ISOLATION RESISTANCE	I/P-O/P:100M Ohms / 500VDC / 25°C / 70% RH		
	ISOLATION LEVEL	Primary-secondary: 1xMOPP / 2xMOOP when system input voltage is with 250VAC, 50/60Hz		
	ISOLATION CAPACITANCE (Typ.)	5pF		
	EMC EMISSION	<b>Parameter</b>	<b>Standard</b>	<b>Test Level / Note</b>
		Conducted	EN55011(CISPR11)	Class B
		Radiated	EN55011(CISPR11)	Class B
	EMC IMMUNITY	<b>Parameter</b>	<b>Standard</b>	<b>Test Level / Note</b>
ESD		EN61000-4-2	Level 2, ±8KV contact	
OTHERS	MTBF	3500Khrs MIL-HDBK-217F(25°C)		
	DIMENSION (L*W*H)	19.5*9.8*12.5mm (0.77*0.386*0.492 inch)		
	CASE MATERIAL	Non-Conductive black plastic (UL 94V-0 rated)		
	PACKING	4.2g		
NOTE	<p>1.All parameters are specified at normal input(L:5Vdc, M:12Vdc, N:24Vdc), rated load, 25°C 70% RH ambient.</p> <p>2.Ripple &amp; noise are measured at 20MHz by using a 12" twisted pair terminated with a 0.1µf &amp; 47µf capacitor.</p> <p>3.Line regulation is measured from low line to high line at rated load.</p> <p>4.Load regulation is measured from 10% to 100% rated load.</p> <p>5.Patient leakage current(2µA max.) and reinforced isolation is based on a 250VAC, 50/60Hz system input voltage.</p> <p>6.The final equipment must be re-confirm that it still meet EMC directives. For guidance on how to perform these EMC tests, please refer to "EMI testing of component power supplies."(as available on <a href="http://www.meanwell.com">http://www.meanwell.com</a>)</p>			

**Mechanical Specification**

- All dimensions in mm(inch)
- Tolerance:  $x.x \pm 0.25\text{mm}$  ( $x.xx \pm 0.01"$ )  
 $x.xx \pm 0.10\text{mm}$  ( $x.xxx \pm 0.004"$ )
- Pin pitch tolerance:  $\pm 0.05\text{mm}$  ( $\pm 0.002"$ )

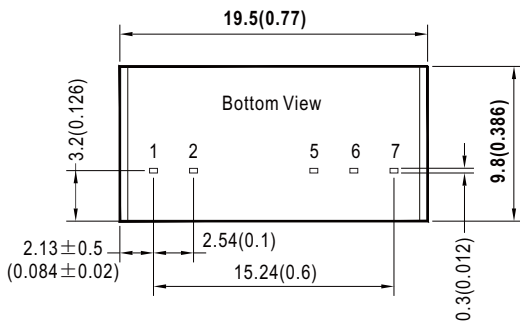
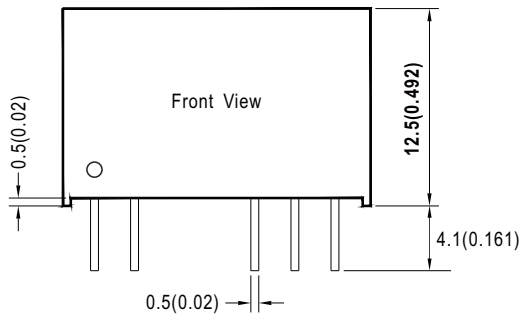

**Plug Assignment**

Pin-Out		
Pin No.	MDS02 (Single output)	MDD02 (Dual output)
1	+Vin	+Vin
2	-Vin	-Vin
5	-Vout	-Vout
6	No pin	Common
7	+Vout	+Vout

**EMC Suggestion**

EMC typical recommended circuit (Class B)

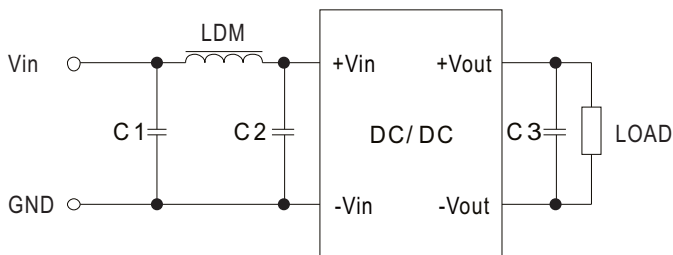

Recommended typical circuit parameters:

Input voltage (V)		3.3/5/12/15/24
EMI	C1,C2	4.7μF/50V
	C3	See table 2
	LDM	6.8μH

Table 1

Single Vout	C3(μF)	Dual Vout	C3(μF)
3.3/5V	10μF	±5V	4.7μF
12V	2.2μF	±9V	2.2μF
15V	1μF	±12V/15V	1μF

Table 2



## Derating Curve

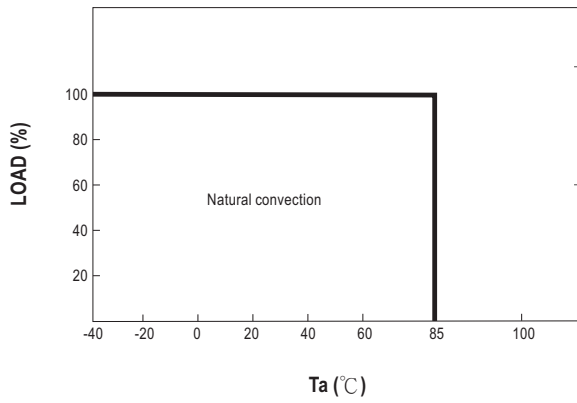

## Installation Manual

Please refer to : <http://www.meanwell.com/manual.html>