

# 5 V ECL 1:9 Differential Clock Driver

## MC100E111

### Description

The MC100E111 is a low skew 1-to-9 differential driver, designed with clock distribution in mind. It accepts one signal input, which can be either differential or else single-ended if the  $V_{BB}$  output is used. The signal is fanned out to 9 identical differential outputs. An enable input is also provided. A HIGH disables the device by forcing all Q outputs LOW and all  $\bar{Q}$  outputs HIGH.

The device is specifically designed, modeled and produced with low skew as the key goal. Optimal design and layout serve to minimize gate to gate skew within-device, and empirical modeling is used to determine process control limits that ensure consistent  $t_{pd}$  distributions from lot to lot. The net result is a dependable, guaranteed low skew device.

The lowest TPD delay time results from terminating only one output pair, and the greatest TPD delay time results from terminating all the output pairs. This shift is about 10–20 pS in TPD. The skew between any two output pairs within a device is typically about 25 nS. If other output pairs are not terminated, the lowest TPD delay time results from both output pairs and the skew is typically 25 nS. When all outputs are terminated, the greatest TPD (delay time) occurs and all outputs display about the same 10–20 pS increase in TPD, so the relative skew between any two output pairs remains about 25 nS.

The  $V_{BB}$  pin, an internally generated voltage supply, is available to this device only. For single-ended input conditions, the unused differential input is connected to  $V_{BB}$  as a switching reference voltage.  $V_{BB}$  may also rebias AC coupled inputs. When used, decouple  $V_{BB}$  and  $V_{CC}$  via a 0.01  $\mu$ F capacitor and limit current sourcing or sinking to 0.5 mA. When not used,  $V_{BB}$  should be left open.

The 100 Series contains temperature compensation.

### Features

- Guaranteed Skew Spec
- Differential Design
- $V_{BB}$  Output
- PECL Mode Operating Range:  $V_{CC} = 4.2$  V to 5.7 V with  $V_{EE} = 0$  V
- NECL Mode Operating Range:  $V_{CC} = 0$  V with  $V_{EE} = -4.2$  V to  $-5.7$  V
- Internal Input 50 k $\Omega$  Pulldown Resistors
- ESD Protection: > 3 kV Human Body Model
- Meets or Exceeds JEDEC Standard EIA/JESD78 IC Latchup Test
- Moisture Sensitivity: Level 3 (Pb-Free)  
(For Additional Information, see Application Note [AND8003/D](#))
- Flammability Rating: UL 94 V-0 @ 0.125 in, Oxygen Index: 28 to 34
- Transistor Count = 178 Devices
- These Devices are Pb-Free, Halogen Free and are RoHS Compliant



ON Semiconductor®

[www.onsemi.com](http://www.onsemi.com)

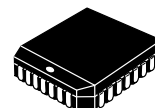

PLCC-28  
FN SUFFIX  
CASE 776-02

### MARKING DIAGRAM\*

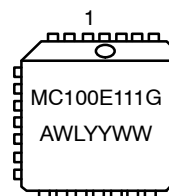

A = Assembly Location  
WL = Wafer Lot  
YY = Year  
WW = Work Week  
G = Pb-Free Package

\*For additional marking information, refer to Application Note [AND8002/D](#).

### ORDERING INFORMATION

Device	Package	Shipping†
MC100E111FNG	PLCC-28 (Pb-Free)	37 Units/Tube
MC100E111FNR2G	PLCC-28 (Pb-Free)	500 / Tape & Reel

†For information on tape and reel specifications, including part orientation and tape sizes, please refer to our Tape and Reel Packaging Specifications Brochure, [BRD8011/D](#).

# MC100E111

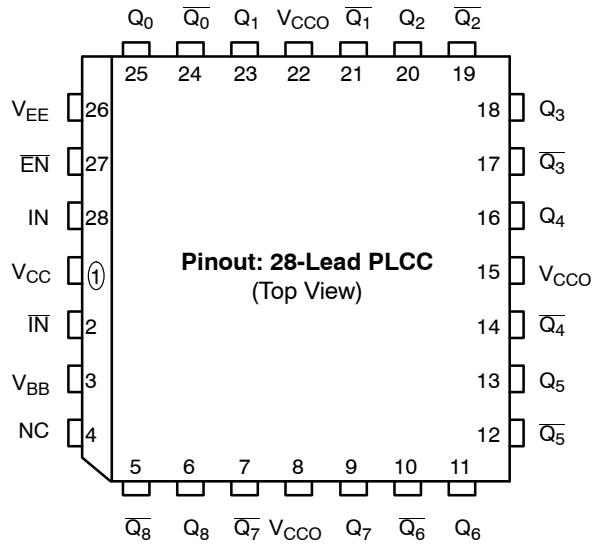

**Table 1. PIN DESCRIPTION**

PIN	FUNCTION
IN, $\overline{\text{IN}}$	ECL Differential Input Pair
EN	ECL Enable
$Q_0, \overline{Q_0}-Q_8, \overline{Q_8}$	ECL Differential Outputs
$V_{BB}$	Reference Voltage Output
$V_{CC}, V_{CCO}$	Positive Supply
$V_{EE}$	Negative Supply
NC	No Connect

\* All  $V_{CC}$  and  $V_{CCO}$  pins are tied together on the die.

Warning: All  $V_{CC}$ ,  $V_{CCO}$ , and  $V_{EE}$  pins must be externally connected to Power Supply to guarantee proper operation.

**Figure 1. 28-Lead Pinout**

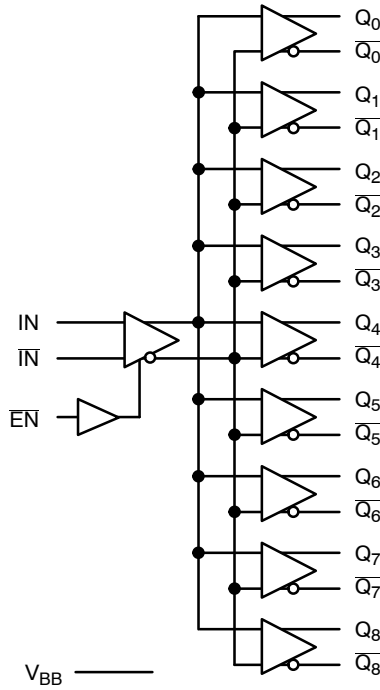

**Figure 2. Logic Symbol**

# MC100E111

**Table 2. MAXIMUM RATINGS**

Symbol	Parameter	Condition 1	Condition 2	Rating	Unit
V <sub>CC</sub>	PECL Mode Power Supply	V <sub>EE</sub> = 0 V		8	V
V <sub>I</sub>	PECL Mode Input Voltage NECL Mode Input Voltage	V <sub>EE</sub> = 0 V V <sub>CC</sub> = 0 V	V <sub>I</sub> ≤ V <sub>CC</sub> V <sub>I</sub> ≥ V <sub>EE</sub>	6 -6	V
I <sub>out</sub>	Output Current	Continuous Surge		50 100	mA
I <sub>BB</sub>	V <sub>BB</sub> Sink/Source			±0.5	mA
T <sub>A</sub>	Operating Temperature Range			-40 to +85	°C
T <sub>stg</sub>	Storage Temperature Range			-65 to +150	°C
θ <sub>JA</sub>	Thermal Resistance (Junction-to-Ambient)	0 lfp 500 lfp	PLCC-28 PLCC-28	63.5 43.5	°C/W
θ <sub>JC</sub>	Thermal Resistance (Junction-to-Case)	Standard Board	PLCC-28	22 to 26	°C/W
T <sub>sol</sub>	Wave Solder (Pb-Free)			265	°C

Stresses exceeding those listed in the Maximum Ratings table may damage the device. If any of these limits are exceeded, device functionality should not be assumed, damage may occur and reliability may be affected.

**Table 3. 100E SERIES PECL DC CHARACTERISTICS** (V<sub>CCx</sub> = 5.0 V; V<sub>EE</sub> = 0.0 V (Note 1))

Symbol	Characteristic	-40°C			25°C			85°C			Unit
		Min	Typ	Max	Min	Typ	Max	Min	Typ	Max	
I <sub>EE</sub>	Power Supply Current		40	60		45	60		50	69	mA
V <sub>OH</sub>	Output HIGH Voltage (Note 2)	3975	4020	4120	3975	4020	4120	3975	4020	4120	mV
V <sub>OL</sub>	Output LOW Voltage (Note 2)	3190	3300	3380	3190	3300	3380	3190	3300	3380	mV
V <sub>IH</sub>	Input HIGH Voltage (Single-Ended)	3835	3975	4120	3835	3975	4120	3835	3975	4120	mV
V <sub>IL</sub>	Input LOW Voltage (Single-Ended)	3190	3355	3525	3190	3355	3525	3190	3355	3525	mV
V <sub>BB</sub>	Output Voltage Reference	3.64		3.75	3.62		3.74	3.62		3.74	V
V <sub>IHCMR</sub>	Input HIGH Voltage Common Mode Range (Differential Configuration) (Note 3)	3.4		4.6	3.4		4.6	3.4		4.6	V
I <sub>IH</sub>	Input HIGH Current			150			150			150	μA
I <sub>IL</sub>	Input LOW Current	0.5			0.5	0.25		0.5	0.2		μA

NOTE: Device will meet the specifications after thermal equilibrium has been established when mounted in a test socket or printed circuit board with maintained transverse airflow greater than 500 lfp.

1. Input and output parameters vary 1:1 with V<sub>CC</sub>. V<sub>EE</sub> can vary -0.46 V / +0.8 V.
2. Outputs are terminated through a 50 Ω resistor to V<sub>CC</sub> - 2.0 V.
3. V<sub>IHCMR</sub> min and max vary 1:1 with V<sub>CC</sub>.

# MC100E111

**Table 4. 100E SERIES NECL DC CHARACTERISTICS** ( $V_{CCx} = 0.0\text{ V}$ ;  $V_{EE} = -5.0\text{ V}$  (Note 1))

Symbol	Characteristic	-40°C			25°C			85°C			Unit
		Min	Typ	Max	Min	Typ	Max	Min	Typ	Max	
$I_{EE}$	Power Supply Current		40	60		45	60		50	69	mA
$V_{OH}$	Output HIGH Voltage (Note 2)	-1025	-980	-880	-1025	-980	-880	-1025	-980	-880	mV
$V_{OL}$	Output LOW Voltage (Note 2)	-1810	-1700	-1620	-1810	-1700	-1620	-1810	-1700	-1620	mV
$V_{IH}$	Input HIGH Voltage (Single-Ended)	-1165	-1025	-880	-1165	-1025	-880	-1165	-1025	-880	mV
$V_{IL}$	Input LOW Voltage (Single-Ended)	-1810	-1645	-1475	-1810	-1645	-1475	-1810	-1645	-1475	mV
$V_{BB}$	Output Voltage Reference	-1.38		-1.25	-1.38		-1.26	-1.38		-1.26	V
$V_{IHCMR}$	Input HIGH Voltage Common Mode Range (Differential Configuration) (Note 3)	-1.6		-0.4	-1.6		-0.4	-1.6		-0.4	V
$I_{IH}$	Input HIGH Current			150			150			150	$\mu\text{A}$
$I_{IL}$	Input LOW Current	0.5			0.5	0.25		0.5	0.2		$\mu\text{A}$

NOTE: Device will meet the specifications after thermal equilibrium has been established when mounted in a test socket or printed circuit board with maintained transverse airflow greater than 500 lfm.

1. Input and output parameters vary 1:1 with  $V_{CC}$ .  $V_{EE}$  can vary  $-0.46\text{ V} / +0.8\text{ V}$ .
2. Outputs are terminated through a  $50\ \Omega$  resistor to  $V_{CC} - 2.0\text{ V}$ .
3.  $V_{IHCMR}$  min and max vary 1:1 with  $V_{CC}$ .

**Table 5. AC CHARACTERISTICS** ( $V_{CCx} = 5.0\text{ V}$ ;  $V_{EE} = 0.0\text{ V}$  or  $V_{CCx} = 0.0\text{ V}$ ;  $V_{EE} = -5.0\text{ V}$  (Note 1))

Symbol	Characteristic	-40°C			25°C			85°C			Unit
		Min	Typ	Max	Min	Typ	Max	Min	Typ	Max	
$f_{MAX}$	Maximum Toggle Frequency		800			800			800		MHz
$t_{PLH}$ $t_{PHL}$	Propagation Delay to Output IN (Diff) (Note 2) IN (SE) (Note 3) Enable (Note 4) Disable (Note 4)	430 380 400 400		630 680 900 900	430 380 450 450		630 680 850 850	430 380 450 450		630 680 850 850	ps
$t_S$	Setup Time (Note 5) $\overline{EN}$ to IN	250	0		200	0		200	0		ps
$t_H$	Hold Time (Note 6) IN to $\overline{EN}$	50	-200		0	-200		0	-200		ps
$t_R$	Release Time (Note 7) $\overline{EN}$ to IN	350	100		300	100		300	100		ps
$t_{skew}$	Within-Device Skew (Note 8)		25	75		25	50		25	50	ps
$t_{JITTER}$	Random Clock Jitter (RMS)		< 1	< 2		< 1	< 2		< 1	< 2	ps
$V_{PP}$	Minimum Input Swing	50			50			50			mV
$t_r, t_f$	Rise/Fall Time	250	450	650	275	375	600	275	375	600	ps

NOTE: Device will meet the specifications after thermal equilibrium has been established when mounted in a test socket or printed circuit board with maintained transverse airflow greater than 500 lfm.

4. The differential propagation delay is defined as the delay from the crossing points of the differential input signals to the crossing point of the differential output signals.
5. The single-ended propagation delay is defined as the delay from the 50% point of the input signal to the 50% point of the output signal.
6. Enable is defined as the propagation delay from the 50% point of a **negative** transition on  $\overline{EN}$  to the 50% point of a **positive** transition on Q (or a negative transition on  $\overline{Q}$ ). Disable is defined as the propagation delay from the 50% point of a **positive** transition on  $\overline{EN}$  to the 50% point of a **negative** transition on Q (or a positive transition on  $\overline{Q}$ ).
7. The setup time is the minimum time that  $\overline{EN}$  must be asserted prior to the next transition of IN/ $\overline{IN}$  to prevent an output response greater than +75 mV to that IN/ $\overline{IN}$  transition (Figure 3).
8. The hold time is the minimum time that  $\overline{EN}$  must remain asserted after a negative going IN or a positive going  $\overline{IN}$  to prevent an output response greater than +75 mV to that IN/ $\overline{IN}$  transition (Figure 4).
9. The release time is the minimum time that  $\overline{EN}$  must be deasserted prior to the next IN/ $\overline{IN}$  transition to ensure an output response that meets the specified IN to Q propagation delay and output transition times (Figure 5).
10. The within-device skew is defined as the worst case difference between any two similar delay paths within a single device.

# MC100E111

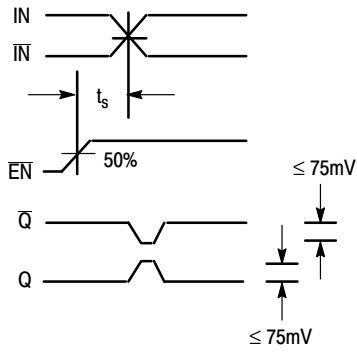

Figure 3. Setup Time

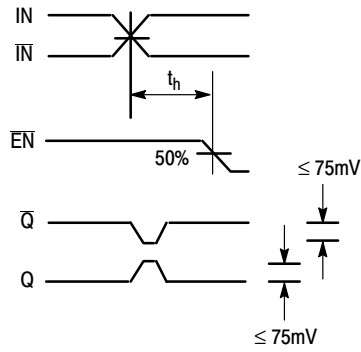

Figure 4. Hold Time

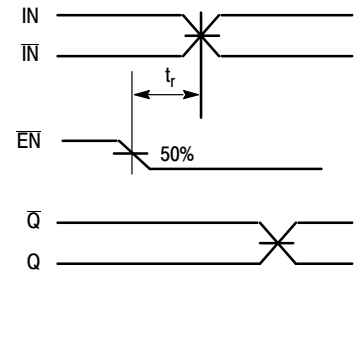

Figure 5. Release Time

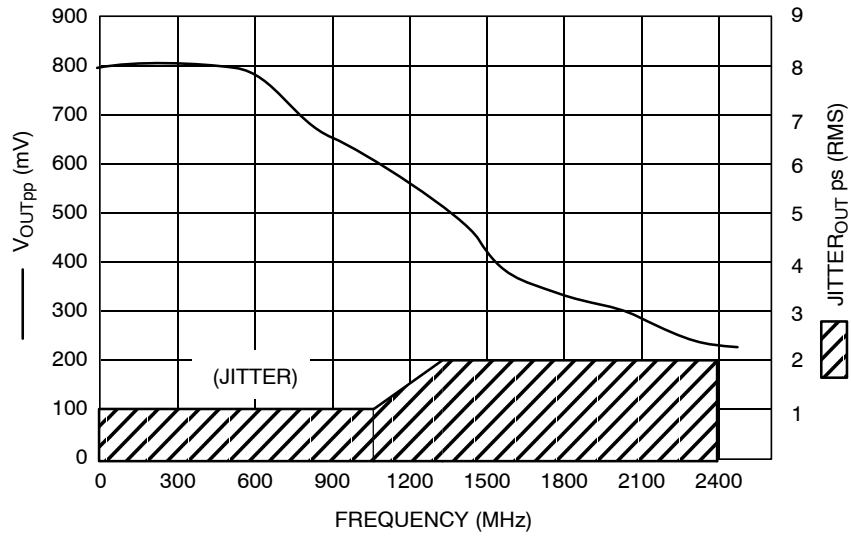

Figure 6.  $F_{max}$ /Jitter

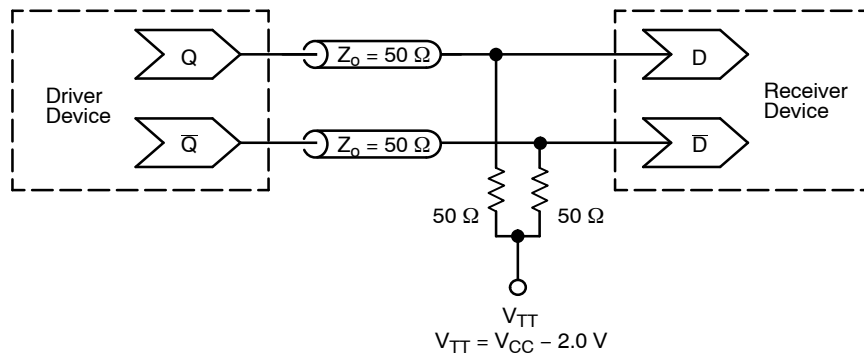

Figure 7. Typical Termination for Output Driver and Device Evaluation  
(See Application Note [AND8020/D](#) – Termination of ECL Logic Devices)

## Resource Reference of Application Notes

- AN1405/D** – ECL Clock Distribution Techniques
- AN1406/D** – Designing with PECL (ECL at +5.0 V)
- AN1503/D** – ECLinPS™ I/O SPiCE Modeling Kit
- AN1504/D** – Metastability and the ECLinPS Family
- AN1568/D** – Interfacing Between LVDS and ECL
- AN1672/D** – The ECL Translator Guide
- AND8001/D** – Odd Number Counters Design
- AND8002/D** – Marking and Date Codes
- AND8020/D** – Termination of ECL Logic Devices
- AND8066/D** – Interfacing with ECLinPS
- AND8090/D** – AC Characteristics of ECL Devices

# MECHANICAL CASE OUTLINE

## PACKAGE DIMENSIONS

ON Semiconductor®

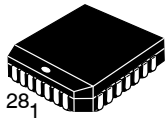

SCALE 1:1

28 LEAD PLCC  
CASE 776-02  
ISSUE G

DATE 06 APR 2021

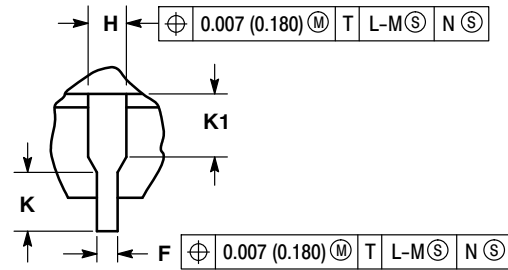
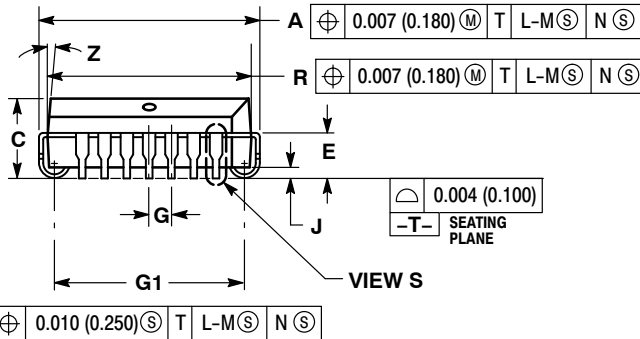
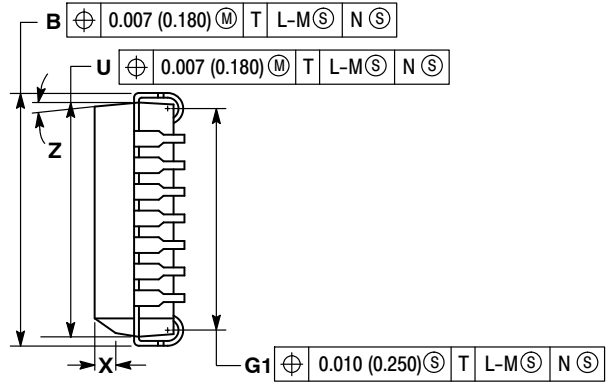
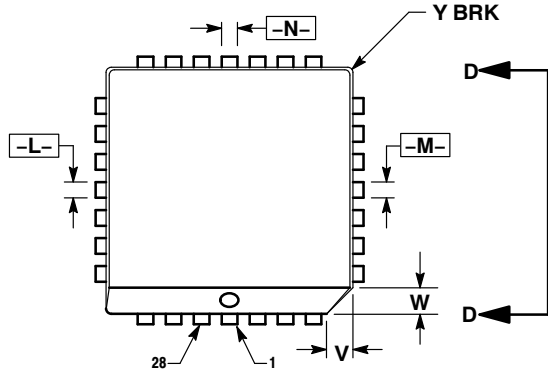

NOTES:

- DATUMS -L-, -M-, AND -N- DETERMINED WHERE TOP OF LEAD SHOULDER EXITS PLASTIC BODY AT MOLD PARTING LINE.
- DIMENSION G1, TRUE POSITION TO BE MEASURED AT DATUM -T-, SEATING PLANE.
- DIMENSIONS R AND U DO NOT INCLUDE MOLD FLASH. ALLOWABLE MOLD FLASH IS 0.010 (0.250) PER SIDE.
- DIMENSIONING AND TOLERANCING PER ANSI Y14.5M, 1982.
- CONTROLLING DIMENSION: INCH.
- THE PACKAGE TOP MAY BE SMALLER THAN THE PACKAGE BOTTOM BY UP TO 0.012 (0.300). DIMENSIONS R AND U ARE DETERMINED AT THE OUTERMOST EXTREMES OF THE PLASTIC BODY EXCLUSIVE OF MOLD FLASH, TIE BAR BURRS, GATE BURRS AND INTERLEAD FLASH, BUT INCLUDING ANY MISMATCH BETWEEN THE TOP AND BOTTOM OF THE PLASTIC BODY.
- DIMENSION H DOES NOT INCLUDE DAMBAR PROTRUSION OR INTRUSION. THE DAMBAR PROTRUSION(S) SHALL NOT CAUSE THE H DIMENSION TO BE GREATER THAN 0.037 (0.940). THE DAMBAR INTRUSION(S) SHALL NOT CAUSE THE H DIMENSION TO BE SMALLER THAN 0.025 (0.635).

DIM	INCHES		MILLIMETERS	
	MIN	MAX	MIN	MAX
A	0.485	0.495	12.32	12.57
B	0.485	0.495	12.32	12.57
C	0.165	0.180	4.20	4.57
E	0.090	0.110	2.29	2.79
F	0.013	0.021	0.33	0.53
G	0.050 BSC		1.27 BSC	
H	0.026	0.032	0.66	0.81
J	0.020	---	0.51	---
K	0.025	---	0.64	---
R	0.450	0.456	11.43	11.58
U	0.450	0.456	11.43	11.58
V	0.042	0.048	1.07	1.21
W	0.042	0.048	1.07	1.21
X	0.042	0.056	1.07	1.42
Y	---	0.020	---	0.50
Z	2° 10°		2° 10°	
G1	0.410	0.430	10.42	10.92
K1	0.040	---	1.02	---

GENERIC MARKING DIAGRAM\*

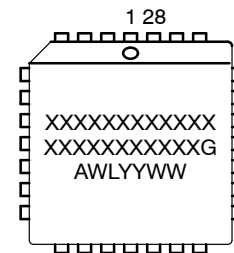

- XXXXX = Specific Device Code
- A = Assembly Location
- WL = Wafer Lot
- YY = Year
- WW = Work Week
- G = Pb-Free Package

\*This information is generic. Please refer to device data sheet for actual part marking. Pb-Free indicator, "G" or microdot "▪", may or may not be present.

DOCUMENT NUMBER:	98ASB42596B	Electronic versions are uncontrolled except when accessed directly from the Document Repository. Printed versions are uncontrolled except when stamped "CONTROLLED COPY" in red.
DESCRIPTION:	28 LEAD PLCC	PAGE 1 OF 1

ON Semiconductor and ON are trademarks of Semiconductor Components Industries, LLC dba ON Semiconductor or its subsidiaries in the United States and/or other countries. ON Semiconductor reserves the right to make changes without further notice to any products herein. ON Semiconductor makes no warranty, representation or guarantee regarding the suitability of its products for any particular purpose, nor does ON Semiconductor assume any liability arising out of the application or use of any product or circuit, and specifically disclaims any and all liability, including without limitation special, consequential or incidental damages. ON Semiconductor does not convey any license under its patent rights nor the rights of others.

ON Semiconductor and  are trademarks of Semiconductor Components Industries, LLC dba ON Semiconductor or its subsidiaries in the United States and/or other countries. ON Semiconductor owns the rights to a number of patents, trademarks, copyrights, trade secrets, and other intellectual property. A listing of ON Semiconductor's product/patent coverage may be accessed at [www.onsemi.com/site/pdf/Patent-Marking.pdf](http://www.onsemi.com/site/pdf/Patent-Marking.pdf). ON Semiconductor reserves the right to make changes without further notice to any products herein. ON Semiconductor makes no warranty, representation or guarantee regarding the suitability of its products for any particular purpose, nor does ON Semiconductor assume any liability arising out of the application or use of any product or circuit, and specifically disclaims any and all liability, including without limitation special, consequential or incidental damages. Buyer is responsible for its products and applications using ON Semiconductor products, including compliance with all laws, regulations and safety requirements or standards, regardless of any support or applications information provided by ON Semiconductor. "Typical" parameters which may be provided in ON Semiconductor data sheets and/or specifications can and do vary in different applications and actual performance may vary over time. All operating parameters, including "Typicals" must be validated for each customer application by customer's technical experts. ON Semiconductor does not convey any license under its patent rights nor the rights of others. ON Semiconductor products are not designed, intended, or authorized for use as a critical component in life support systems or any FDA Class 3 medical devices or medical devices with a same or similar classification in a foreign jurisdiction or any devices intended for implantation in the human body. Should Buyer purchase or use ON Semiconductor products for any such unintended or unauthorized application, Buyer shall indemnify and hold ON Semiconductor and its officers, employees, subsidiaries, affiliates, and distributors harmless against all claims, costs, damages, and expenses, and reasonable attorney fees arising out of, directly or indirectly, any claim of personal injury or death associated with such unintended or unauthorized use, even if such claim alleges that ON Semiconductor was negligent regarding the design or manufacture of the part. ON Semiconductor is an Equal Opportunity/Affirmative Action Employer. This literature is subject to all applicable copyright laws and is not for resale in any manner.

## PUBLICATION ORDERING INFORMATION

### LITERATURE FULFILLMENT:

Email Requests to: [orderlit@onsemi.com](mailto:orderlit@onsemi.com)

ON Semiconductor Website: [www.onsemi.com](http://www.onsemi.com)

### TECHNICAL SUPPORT

North American Technical Support:  
Voice Mail: 1 800-282-9855 Toll Free USA/Canada  
Phone: 011 421 33 790 2910

Europe, Middle East and Africa Technical Support:

Phone: 00421 33 790 2910

For additional information, please contact your local Sales Representative