



**HIRSCHMANN**

A **BELDEN** BRAND

# User Manual

## Installation

### Industrial Ethernet Workgroup Switch

### MACH104 Full Gigabit Family

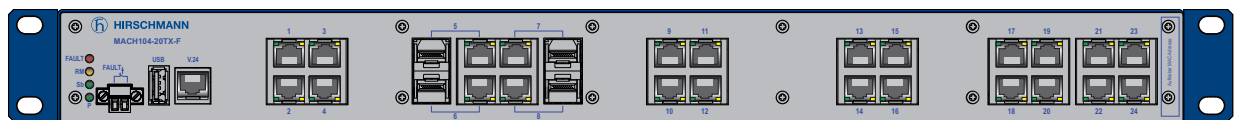

MACH104-20TX-F...

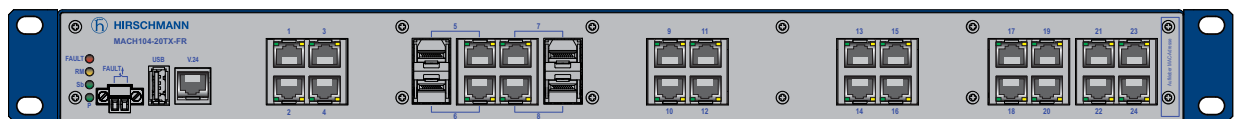

MACH104-20TX-FR...

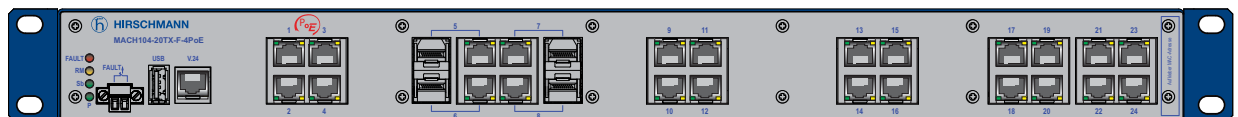

MACH104-20TX-F-4PoE...

The naming of copyrighted trademarks in this manual, even when not specially indicated, should not be taken to mean that these names may be considered as free in the sense of the trademark and tradename protection law and hence that they may be freely used by anyone.

© 2019 Hirschmann Automation and Control GmbH

Manuals and software are protected by copyright. All rights reserved. The copying, reproduction, translation, conversion into any electronic medium or machine scannable form is not permitted, either in whole or in part. An exception is the preparation of a backup copy of the software for your own use.

The performance features described here are binding only if they have been expressly agreed when the contract was made. This document was produced by Hirschmann Automation and Control GmbH according to the best of the company's knowledge. Hirschmann reserves the right to change the contents of this document without prior notice. Hirschmann can give no guarantee in respect of the correctness or accuracy of the information in this document.

Hirschmann can accept no responsibility for damages, resulting from the use of the network components or the associated operating software. In addition, we refer to the conditions of use specified in the license contract.

You can get the latest version of this manual on the Internet at the Hirschmann product site ([www.hirschmann.com](http://www.hirschmann.com)).

Hirschmann Automation and Control GmbH  
Stuttgarter Str. 45-51  
72654 Neckartenzlingen  
Germany

# Contents

<b>Safety instructions</b>	<b>5</b>
<b>About this manual</b>	<b>13</b>
<b>Legend</b>	<b>14</b>
<b>1 Description</b>	<b>15</b>
1.1 General device description	15
1.2 Description of the device variants	16
1.2.1 MACH104-20TX-F...: Devices with 24 GB ports	16
1.2.2 MACH104-20TX-FR...: Devices with 24 GB ports and redundant power supply	17
1.2.3 MACH104-20TX-F-4-PoE...: Devices with 24 GB ports, 4 of them PoE ports	18
1.3 Supply voltage	19
1.3.1 MACH104-20TX-F...	19
1.3.2 MACH104-20TX-FR...	19
1.3.3 MACH104-20TX-F-4-PoE...	20
1.4 Ethernet ports	20
1.4.1 10/100/1000 Mbit/s twisted pair port	20
1.4.2 100 Mbit/s F/O port	21
1.4.3 1000 Mbit/s F/O port	21
1.4.4 PoE ports	21
1.4.5 Combo ports	22
1.5 Display elements	22
1.5.1 Device state	23
1.5.2 Port status	24
1.6 Management interfaces	25
1.6.1 V.24 interface (external management)	25
1.6.2 USB interface	26
1.7 Signal contact	26
<b>2 Installation</b>	<b>27</b>
2.1 Checking the package contents	27
2.2 Installing an SFP transceiver (optional)	27

2.3	Wiring and installing the signal contact	28
2.4	Installing the device and grounding	29
2.4.1	Selecting the assembly location	29
2.4.2	Mounting on a flat surface	29
2.4.3	Mounting in a switch cabinet	29
2.4.4	Mounting on the wall	30
2.4.5	Grounding the device	31
2.5	Operating the device	32
2.6	Connecting data cables	32
<b>3</b>	<b>Making basic settings</b>	<b>33</b>
3.1	Default settings	34
<b>4</b>	<b>Maintenance and service</b>	<b>35</b>
<b>5</b>	<b>Deinstallation</b>	<b>36</b>
5.1	Removing the device	36
5.2	Removing an SFP transceiver (optional)	36
<b>6</b>	<b>Technical data</b>	<b>37</b>
6.1	General technical data	37
6.2	Dimension drawings	38
6.3	EMC and immunity	38
6.4	Network range	40
6.5	Power consumption/power output	43
<b>7</b>	<b>Scope of delivery, order numbers and accessories</b>	<b>44</b>
<b>8</b>	<b>Underlying technical standards</b>	<b>47</b>
<b>A</b>	<b>Further support</b>	<b>48</b>

# Safety instructions

## **WARNING**

### **UNCONTROLLED MACHINE ACTIONS**

To avoid uncontrolled machine actions caused by data loss, configure all the data transmission devices individually.

Before you start any machine which is controlled via data transmission, be sure to complete the configuration of all data transmission devices.

**Failure to follow these instructions can result in death, serious injury, or equipment damage.**

### ■ **General safety instructions**

You operate this device with electricity. Improper usage of the device entails the risk of physical injury or significant property damage. The proper and safe operation of this device depends on proper handling during transportation, proper storage and installation, and careful operation and maintenance procedures.

- Before connecting any cable, read this document, and the safety instructions and warnings.
- Operate the device with undamaged components exclusively.
- The device is free of any service components. In case of a damaged or malfunctioning device, turn off the supply voltage and return the device to Hirschmann for inspection.

### ■ **Qualification requirements for personnel**

- Only allow qualified personnel to work on the device.

Qualified personnel have the following characteristics:

- ▶ Qualified personnel are properly trained. Training as well as practical knowledge and experience make up their qualifications. This is the prerequisite for grounding and labeling circuits, devices, and systems in accordance with current standards in safety technology.
- ▶ Qualified personnel are aware of the dangers that exist in their work.
- ▶ Qualified personnel are familiar with appropriate measures against these hazards in order to reduce the risk for themselves and others.
- ▶ Qualified personnel receive training on a regular basis.

## ■ Certified usage

- Use the product only for the application cases described in the Hirschmann product information, including this manual.
- Operate the product only according to the technical specifications.  
See “Technical data” on page 37.
- Connect to the product only components suitable for the requirements of the specific application case.

## ■ National and international safety regulations

- Verify that the electrical installation meets local or nationally applicable safety regulations.

## ■ Grounding the device

The device is grounded via the power supply connections.

## ■ Requirements for connecting electrical wires

Before connecting the electrical wires, **always** verify that the requirements listed are complied with.

### The following requirements apply without restrictions:

- ▶ The electrical wires are voltage-free.
- ▶ The cables used are permitted for the temperature range of the application case.
- ▶ Only switch on the device when the casing is closed.
- ▶ Relevant for North America:  
Exclusively use 60/75 °C (140/167 °F) or 75 °C (167 °F) copper (Cu) wire.

## ■ Requirements for connecting the supply voltage

Before connecting the supply voltage, **always** verify that the requirements listed are complied with.

### Prerequisites:

All of the following requirements are complied with:

- ▶ The supply voltage corresponds to the voltage specified on the type plate of the device.
- ▶ The power supply conforms to overvoltage category I or II.
- ▶ The power supply has an easily accessible disconnecting device (for example a switch or a plug). This disconnecting device is clearly identified. So in the case of an emergency, it is clear which disconnecting device belongs to which power supply cable.
- ▶ This applies to the following device variants only:
  - ▶ MACH104-20TX-FR...  
Unplug every non-heating device coupling to disconnect the device from the power supply.
- ▶ This applies to the following device variants only:
  - ▶ MACH104-20TX-FR...  
The wire diameter of the power supply cable is at least 1 mm<sup>2</sup> (North America: AWG16) on the supply voltage input.
- ▶ The cross-section of the ground conductor is the same size as or bigger than the cross-section of the power supply cables.
- ▶ The power supply cable is suitable for the voltage, the current and the physical load.  
Hirschmann recommends a wire diameter of 0.5 mm<sup>2</sup> to 0.75 mm<sup>2</sup> (AWG20 up to AWG18).

The following requirements apply alternatively:

---

**Prerequisites:**

---

Relevant when the device is supplied via 1 voltage input:

---

Alternative 1 The power supply complies with the requirements for a limited power source (LPS) as per EN 60950-1.

---

Alternative 2 Relevant for North America:  
The power supply complies with the requirements according to NEC Class 2.

---

Alternative 3 **All** of the following requirements are complied with:

- ▶ The power supply complies with the requirements for a safety extra-low voltage (SELV) as per IEC/EN 60950-1.
- ▶ Supply with DC voltage:  
A fuse suitable for DC voltage is located in the plus conductor of the power supply.  
The minus conductor is on ground potential. Otherwise, a fuse is also located in the minus conductor.  
Regarding the properties of this fuse:  
[See “Technical data” on page 37.](#)
- ▶ Supply with AC voltage:  
A fuse is located in the outer conductor of the power supply.  
The neutral conductor is on ground potential at both voltage inputs.  
Otherwise, a fuse is also located in the neutral conductor.  
Regarding the properties of this fuse:  
[See “Technical data” on page 37.](#)

---

Relevant when the device is supplied via 2 voltage inputs:

---

Alternative 1 The **total** voltage supply meets the requirements for a limited power source (LPS) as per EN 60950-1.

---

Alternative 2 Relevant for North America:  
The **total** voltage supply complies with the requirements as per NEC Class 2.

---

Alternative 3 **All** of the following requirements are complied with:

- ▶ The power supply complies with the requirements for a safety extra-low voltage (SELV) as per IEC/EN 60950-1.
- ▶ Supply with DC voltage:  
A fuse suitable for DC voltage is located at both voltage inputs in the plus conductor of the power supply.  
The minus conductor is on ground potential at both voltage inputs.  
Otherwise, a fuse is also located in the minus conductor.  
Regarding the properties of this fuse:  
[See “Technical data” on page 37.](#)
- ▶ Supply with AC voltage:  
A fuse is located at both voltage inputs in the outer conductor of the power supply.  
The neutral conductor is on ground potential at both voltage inputs.  
Otherwise, a fuse is also located in the neutral conductor.  
Regarding the properties of this fuse:  
[See “Technical data” on page 37.](#)

---

## ■ **Supply voltage**

The supply voltage is connected to the device casing through protective elements exclusively.

The supply voltage is electrically isolated from the casing.

## ■ **Device casing**

Only technicians authorized by the manufacturer are permitted to open the casing.

- Never insert sharp objects (small screwdrivers, wires, etc.) into the inside of the device.
- Keep the ventilation slits free to ensure good air circulation.
- Make sure there is at least 3.94 in (10 cm) of space in front of the ventilation slits of the casing.
- Mount the device horizontally or vertically, either as a desktop device, in the switch cabinet ([figure 12 on page 30](#)) or on the wall ([figure 14 on page 31](#)).

## ■ **CE marking**

The labeled devices comply with the regulations contained in the following European directive(s):

2011/65/EU (RoHS)

Directive of the European Parliament and of the Council on the restriction of the use of certain hazardous substances in electrical and electronic equipment.

2014/30/EU (EMC)

Directive of the European Parliament and the council for standardizing the regulations of member states with regard to electromagnetic compatibility.

2014/35/EU

Directive of the European Parliament and of the Council on the harmonisation of the laws of the Member States relating to the making available on the market of electrical equipment designed for use within certain voltage limits.

In accordance with the above-named EU directive(s), the EU conformity declaration will be at the disposal of the relevant authorities at the following address:

Hirschmann Automation and Control GmbH  
Stuttgarter Str. 45-51  
72654 Neckartenzlingen  
Germany

The product can be used in the industrial sector.

- ▶ Interference immunity: EN 61000-6-2
- ▶ Emitted interference: EN 55032

**Warning!** This is a class A device. This device can cause interference in living areas, and in this case the operator may be required to take appropriate measures.

**Note:** The assembly guidelines provided in these instructions must be strictly adhered to in order to observe the EMC threshold values.

## ■ **LED or laser components**

LED or LASER components according to IEC 60825-1 (2014):

CLASS 1 LASER PRODUCT

CLASS 1 LED PRODUCT

## ■ **FCC note:**

This device complies with part 15 of the FCC rules. Operation is subject to the following two conditions: (1) this device may not cause harmful interference; (2) this device must accept any interference received, including interference that may cause undesired operation.

Appropriate testing has established that this device fulfills the requirements of a class A digital device in line with part 15 of the FCC regulations.

These requirements are designed to provide sufficient protection against interference when the device is being used in a business environment.

The device creates and uses high frequencies and can also radiate these frequencies. If it is not installed and used in accordance with this operating manual, it can cause radio transmission interference. The use of this device in a residential area can also cause interference, and in this case the user is obliged to cover the costs of removing the interference.

## ■ **BSMI note for use in Taiwan**

**Warning!** This is a class A device. This device can cause interference in living areas, and in this case the operator may be required to take appropriate measures.

Devices with a specification according to BSMI standards CNS 13438, CNS 14336-1 and CNS 15663 are marked on the device label.



D45625  
RoHS

警告使用者：

這是甲類的資訊產品，在居住的環境中使用時，可能會造成射頻干擾，在這種情況下，使用者會被要求採取某些適當的對策。

# 限用物質含有情況標示聲明書

Declaration of hazardous substances according to Chinese regulatory standard

設備名稱：交換機，型號（型式）：  
 MACH104-20TX-FR...  
 MACH104-20TX-FR...  
 MACH104-20TX-F-4PoE...

單元 Component	限用物質及其化學符號 Restricted substances and their chemical symbol					
	鉛 (Pb) Lead	汞 (Hg) Mercury	鎘 (Cd) Cadmium	六價 (Cr (VI)) Hexavalent Chromium	多溴聯苯 (PBB) Polybrominated biphenyls	多溴二苯醚 (PBDE) Polybrominated diphenyl ethers
金屬部件 Metal components	X	O	O	O	O	O
電路模組 Printed circuit board assembly	X	O	O	O	O	O
塑膠和聚合物部件 Plastic and polymeric components	O	O	O	O	O	O
電源元件 Power supply unit	X	O	O	O	O	O

備考1. “超出0.1 wt %”及“超出0.01 wt %”係指限用物質之百分比含量超出百分比含量基準值。

Note 1: “Exceeding 0.1 wt%” and “exceeding 0.01 wt%” indicates that the amount of the restricted substance within the component exceeds the reference percentage limit.

備考2. “O”係指該項限用物質之百分比含量未超出百分比含量基準值。

Note 2: “O” indicates that the amount of the restricted substance does not exceed the reference percentage limit.

備考3. “X”係指該項限用物質為排除項目。

Note 3: “X” indicates that the amount of the restricted substance corresponds with the exemption.

## ■ **Relevant for installations in switch cabinets according to UL 60950-1**

- ▶ Higher ambient air temperature during operation: If installed in a closed switch cabinet or a multi-unit switch cabinet, the ambient air temperature inside the switch cabinet during operation can be higher than the ambient air temperature in the room. Install devices in environments that are compatible with the maximum ambient air temperature of the device.
- ▶ Reduced air flow: When you install the device in a switch cabinet, make sure that a sufficient air flow is guaranteed in order to safely operate your devices.
- ▶ Mechanical stress: Check for potential dangers resulting from unevenly distributed weight when you install the device in a switch cabinet.
- ▶ Electric circuit overloading: Observe the effects of electric circuit overloads on the overload current protection and the power supply cables when you connect devices to the power supply. Refer to the device parameters specified on the type plate of the device.
- ▶ Safe grounding: Make sure that devices installed in switch cabinets are grounded safely. When you install a device in a switch cabinet, also watch out for power supply connections other than the direct connections to the circuit branch (for example socket boards).

## ■ **Recycling note**

After usage, this device must be disposed of properly as electronic waste, in accordance with the current disposal regulations of your county, state, and country.

# About this manual

The “Installation” user manual contains a device description, safety instructions, a description of the display, and the other information that you need to install the device.

The following manuals are available as PDF files on the Internet on the Hirschmann product pages ([www.hirschmann.com](http://www.hirschmann.com)):

- ▶ Installation user manual
- ▶ Basic Configuration user manual
- ▶ Redundancy Configuration user manual
- ▶ Reference manual for the graphical user interface
- ▶ Command Line Interface reference manual

The Network Management Software Industrial HiVision provides you with options for smooth configuration and monitoring. You find further information on the Internet at the Hirschmann product pages: <http://www.hirschmann.com/en/QR/INET-Industrial-HiVision>

# Legend

The symbols used in this manual have the following meanings:

▶	Listing
□	Work step
■	Subheading

# 1 Description

## 1.1 General device description

The MACH104 family provides you with a range of device variants. The device is designed for the special requirements of industrial automation. The device meets the relevant industry standards, provides very high operational reliability, even under extreme conditions, and also long-term reliability and flexibility.

The devices with software variant L2... allow you to set up switched industrial Ethernet networks that conform to the IEEE 802.3 standard.

The devices with software variant L2... allow you to set up switched and routed industrial Ethernet networks that conform to the IEEE 802.3 standard. The devices work without a fan.

The following installation options are available:

- ▶ 19" switch cabinet
- ▶ Mounting on a flat surface

You have the option of choosing various media to connect to the end devices and other network components:

- ▶ Twisted pair cable
- ▶ Multimode F/O
- ▶ Singlemode F/O

The ring redundancy concept allows the network to be reconfigured quickly after a failure.

There are convenient options for managing the device. Manage your devices via:

- ▶ Web browser
- ▶ Telnet
- ▶ Network management software (for example Industrial HiVision)
- ▶ V.24 interface (locally on the device)

The device provides you with a large range of functions, which the manuals for the operating software inform you about. You can download these manuals as PDF files from the Internet on the Hirschmann product pages ([www.hirschmann.com](http://www.hirschmann.com)).

The Hirschmann network components help you ensure continuous communication across all levels of the company.

## 1.2 Description of the device variants

### 1.2.1 MACH104-20TX-F...: Devices with 24 GB ports

- ▶ MACH104-20TX-F...
  - ▶ 4 Gigabit Ethernet combo ports
  - ▶ 20 Gigabit Ethernet ports

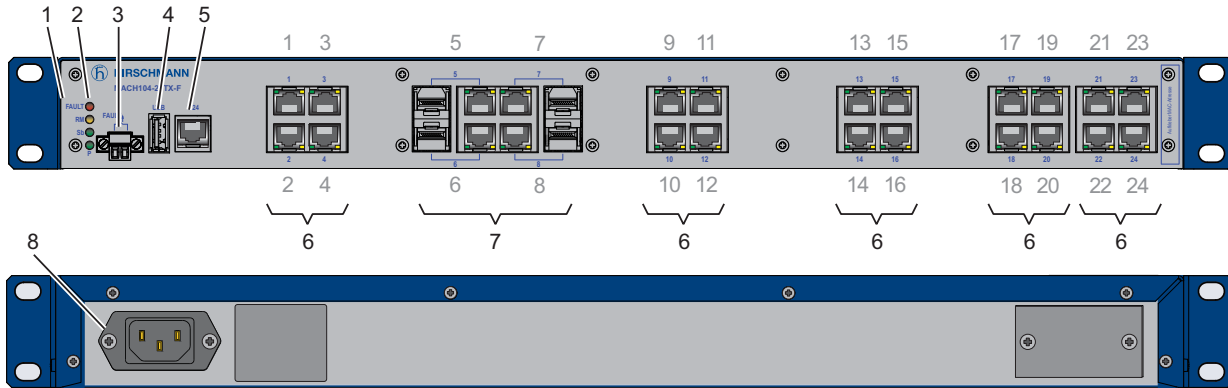

Figure 1: Overview over interfaces, display and operating elements of the MACH104-20TX-F...

- 1 - MACH104-20TX-F... device
- 2 - LED display elements
- 3 - Signal contact
- 4 - USB interface
- 5 - V.24 interface for external management
- 6 - See the following table, column 1
- 7 - See the following table, column 2
- 8 - Power supply connection (on the back of the device)

4 × Gigabit Ethernet ports	4 × Gigabit Ethernet combo ports
10/100/1000 Mbit/s twisted pair, RJ45 sockets	100/1000 Mbit/s F/O, SFP slots Alternatively: 10/100/1000 Mbit/s twisted pair, RJ45 sockets

## 1.2.2 MACH104-20TX-FR...: Devices with 24 GB ports and redundant power supply

- ▶ MACH104-20TX-FR...
  - ▶ 4 Gigabit Ethernet combo ports
  - ▶ 20 Gigabit Ethernet ports
  - ▶ The power supply is designed redundantly.

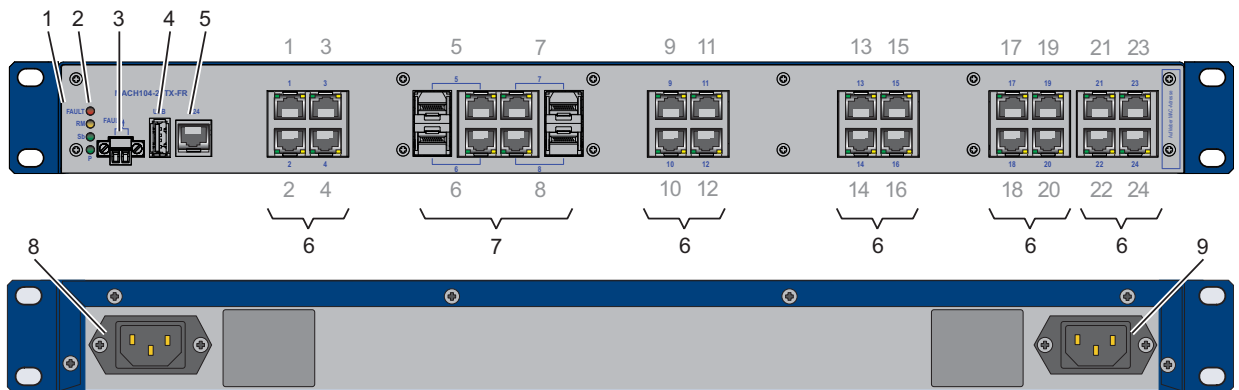

Figure 2: Overview over interfaces, display and operating elements of the MACH104-20TX-FR...

- 1 - MACH104-20TX-FR... device
- 2 - LED display elements
- 3 - Signal contact
- 4 - USB interface
- 5 - V.24 interface for external management
- 6 - See the following table, column 1
- 7 - See the following table, column 2
- 8 - P1: Power supply connection (on the back of the device)
- 9 - P2: Redundant power supply connection (on the back of the device)

4 × Gigabit Ethernet ports	4 × Gigabit Ethernet combo ports
10/100/1000 Mbit/s twisted pair, RJ45 sockets	100/1000 Mbit/s F/O, SFP slots Alternatively: 10/100/1000 Mbit/s twisted pair, RJ45 sockets

### 1.2.3 MACH104-20TX-F-4-PoE...: Devices with 24 GB ports, 4 of them PoE ports

- ▶ MACH104-20TX-F-4-PoE...
  - ▶ 4 Gigabit Ethernet combo ports
  - ▶ 20 Gigabit Ethernet ports, 4 of which are PoE-capable
  - ▶ Integrated PoE voltage supply for 4 PoE ports

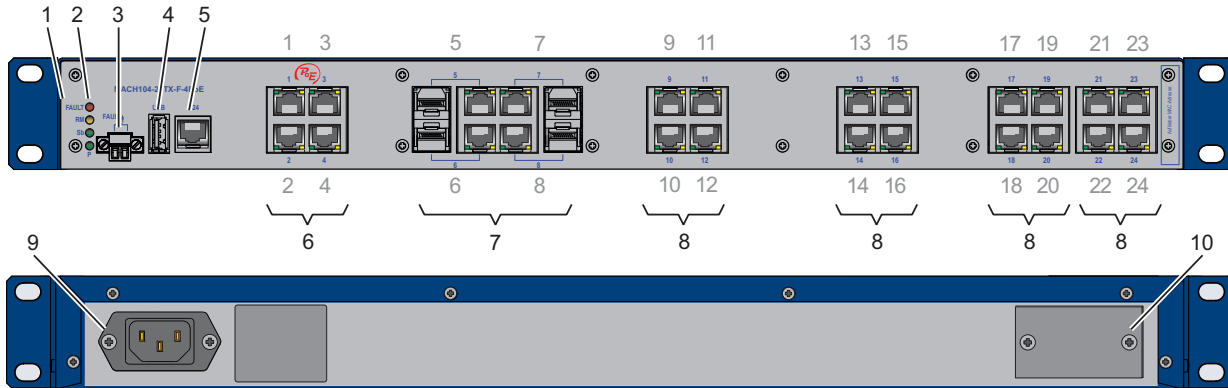

Figure 3: Overview over interfaces, display and operating elements of the MACH104-20TX-F-4-PoE...

- 1 - MACH104-20TX-F-4-PoE... device
- 2 - LED display elements
- 3 - Signal contact
- 4 - USB interface
- 5 - V.24 interface for external management
- 6 - See the following table, column 1
- 7 - See the following table, column 2
- 8 - See the following table, column 3
- 9 - Power supply connection (on the back of the device)
- 10 - Integrated PoE PSU (on the back of the device)

4 × Gigabit Ethernet PoE ports	4 × Gigabit Ethernet combo ports	4 × Gigabit Ethernet ports
10/100/1000 Mbit/s twisted pair, RJ45 sockets with PoE	100/1000 Mbit/s F/O, SFP slots Alternatively: 10/100/1000 Mbit/s twisted pair, RJ45 sockets	10/100/1000 Mbit/s twisted pair, RJ45 sockets

## 1.3 Supply voltage

**Note:** Note the safety instructions in “Requirements for connecting electrical wires” on page 6.

### 1.3.1 MACH104-20TX-F...

Supply voltage is connected via a non-heating appliance socket.

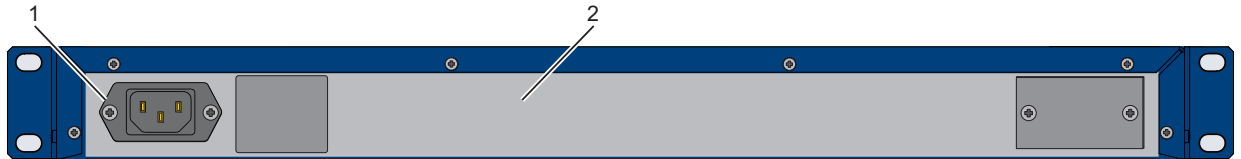

Figure 4: MACH104-20TX-F connections on the back of the device  
1 - Power supply 100 V AC ... 240 V AC  
2 - MACH104-20TX-F... device

### 1.3.2 MACH104-20TX-FR...

Supply voltage is connected via non-heating appliance sockets. The supply voltage can be connected redundantly. Both inputs are uncoupled. The load is not distributed. With redundant supply, the standard power supply supplies the device on its own. The redundant power supply becomes active automatically if the standard power supply fails. Normally the redundant power supply runs in stand-by mode. The supply voltage is electrically isolated from the casing.

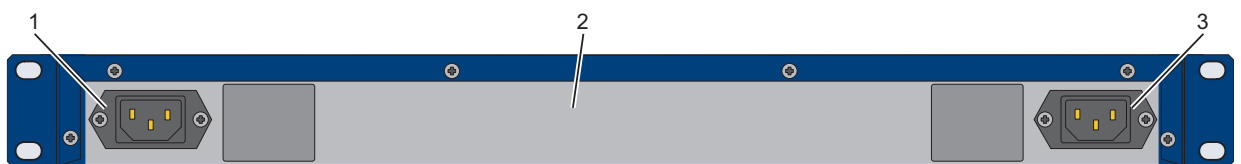

Figure 5: MACH104-20TX-FR... connections on the back of the device  
1 - Standard power supply 100 V AC ... 240 V AC  
2 - MACH104-20TX-FR... device  
3 - Redundant power supply 100 V AC ... 240 V AC

With a non-redundant supply of the supply voltage, the device reports the loss of a supply voltage. You can prevent this message by applying the supply voltage via both inputs, or by changing the configuration in the Management.

### 1.3.3 MACH104-20TX-F-4-PoE...

Supply voltage is connected via a non-heating appliance socket.

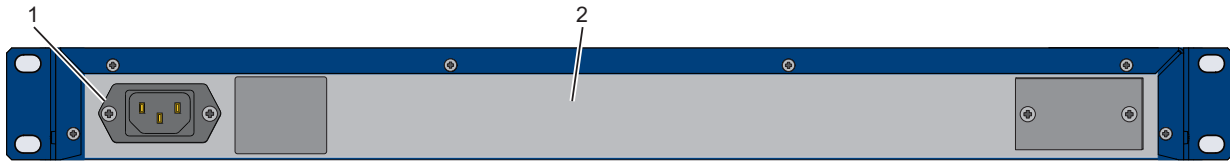

Figure 6: MACH104-20TX-F-4-PoE... connections on the back of the device  
1 - Standard power supply 100 V AC ... 240 V AC  
2 - MACH104-20TX-F-4-PoE... device

## 1.4 Ethernet ports

You can connect end devices and other segments to the device ports using twisted pair cables or optical fibers (F/O).

### 1.4.1 10/100/1000 Mbit/s twisted pair port

This port is an RJ45 socket.

The 10/100/1000 Mbit/s twisted pair port allows you to connect network components according to the IEEE 802.3 10BASE-T/100BASE-TX/1000BASE-T standard.

This port supports:

- ▶ Autonegotiation
- ▶ Autopolarity
- ▶ Autocrossing (if autonegotiation is activated)
- ▶ 1000 Mbit/s full duplex
- ▶ 100 Mbit/s half-duplex mode, 100 Mbit/s full duplex mode
- ▶ 10 Mbit/s half-duplex mode, 10 Mbit/s full duplex mode

**Note:** Some of these ports also support Power over Ethernet (PoE).

See [“PoE ports” on page 21](#).

Delivery state: Autonegotiation activated

The port casing is electrically connected to the front panel.

The pin assignment corresponds to MDI-X.

Figure	Pin	Function	Ports with PoE support: PoE voltage feed
	1	BI_DB+	Minus terminal of the supply voltage
	2	BI_DB-	Minus terminal of the supply voltage
	3	BI_DA+	Plus terminal of the supply voltage
	4	BI_DD+	
	5	BI_DD-	
	6	BI_DA-	Plus terminal of the supply voltage
	7	BI_DC+	
	8	BI_DC-	

Table 1: Pin assignment of a 1000 MBit/s TP interface in MDI-X mode, RJ45 socket - for PoE with the power supplied via the wire pairs transmitting the signal

### 1.4.2 100 Mbit/s F/O port

This port is an SFP slot.

The 100 Mbit/s F/O port allows you to connect network components according to the IEEE 802.3 100BASE-FX standard.

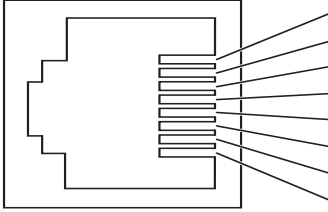
This port supports:

- ▶ Full or half duplex mode

Default setting: Full duplex

### 1.4.3 1000 Mbit/s F/O port

This port is an SFP slot.

The 1000 Mbit/s F/O port offers you the ability to connect network components according to the IEEE 802.3 100BASE-SX/1000BASE-LX standard.

This port supports:

- ▶ Autonegotiation
- ▶ Full duplex mode

Delivery state: Autonegotiation activated

### 1.4.4 PoE ports

The device variants MACH104-20TX-F-4-PoE... support Power over Ethernet (PoE) in accordance with IEEE 802.3af.

Ports	PoE support
1 to 4	Yes
5 to 20	No

Table 2: Twisted-pair ports and PoE support

The PoE ports support the connection and a remote power supply of (for example) IP phones (Voice-over-IP), webcams, sensors, print servers, and WLAN access points. With PoE, these end devices are powered via the twisted pair cable.

The following applies to PoE ports:

- ▶ max. Powered Device (PD) class 0 (15.4 W)
- ▶ The PoE power is supplied via the wire pairs transmitting the signal (phantom voltage).
- ▶ The individual ports (joint PoE voltage) are not electrically insulated from each other.

### 1.4.5 Combo ports

You have the option of alternatively connecting a twisted pair cable via a RJ45 socket or an optical fiber via a SFP transceiver to a combo port. By inserting a SFP transceiver, you deactivate automatically the corresponding twisted pair interface.

## 1.5 Display elements

After the supply voltage is set up, the Software starts and initializes the device. Afterwards, the device performs a self-test. During this process, various LEDs light up.

The process takes around 15 seconds.

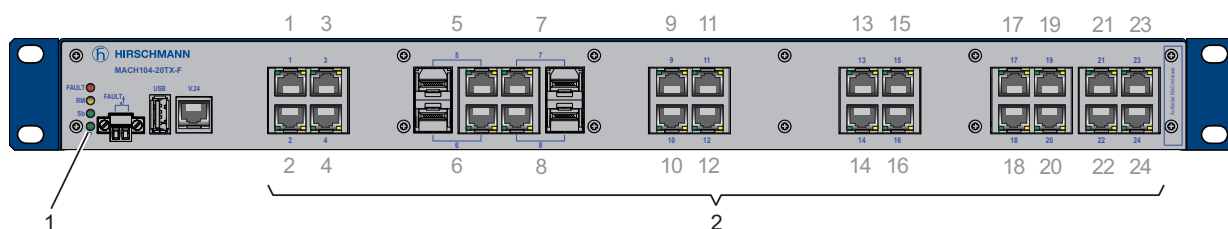
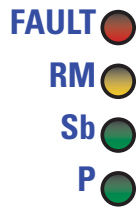

Figure 7: MACH104-Display elements  
1 - Display elements device status  
2 - Display elements port status

## 1.5.1 Device state



These LEDs provide information about conditions which affect the operation of the whole device.

The following table applies to the stated device variants only:

► MACH104-20TX-FR...

LED	Display	Color	Activity	Meaning
P	Supply voltage	—	none	Supply voltages 1 <b>and</b> 2 are too low.
		green	lights up	Supply voltage 1 <b>and</b> 2 is on
		yellow	lights up	Supply voltage 1 <b>or</b> 2 is on

The following table applies to the stated device variants only:

► MACH104-20TX-F...

► MACH104-20TX-F-4-PoE...

LED	Display	Color	Activity	Meaning
P	Supply voltage	—	none	Supply voltage is too low
		green	lights up	Supply voltage is on

The following table applies to every device variant:

LED	Display	Color	Activity	Meaning
Sb	Stand-by	—	none	Stand-by mode not enabled
		green	lights up	Standby mode enabled
FAULT	Signal contact	—	none	The signal contact is closed, it is <b>not</b> reporting any detected errors.
		red	lights up	The signal contact is open - it is reporting a detected error.
RM	Ring Manager	—	none	The RM function is deactivated.
		green	lights up	The RM function is active. The redundant port is disabled.
			flashing	The device detects an incorrect configuration of the HIPER-Ring (for example the ring is not connected to the ring port).
		yellow	lights up	The RM function is active. The redundant port is enabled.

LED	Display	Color	Activity	Meaning
RM and Sb	ACA memory operations	green	Flashing alternately	Error in the memory operation
			flashes synchronously 2 × per period	Saves a configuration file from the storage medium ACA to the device.
			flashes synchronously 1 × per period	Saves a configuration file from the device to the storage medium ACA.

If the manual setting is active on the signal contact “FAULT”, then the error display is independent of the setting of the signal contact.

## 1.5.2 Port status

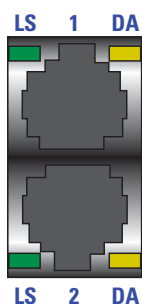

These LEDs display port-related information.

LED	Display	Color	Activity	Meaning
LS	Link status	—	none	Device detects an invalid or missing link
		green	lights up	Device detects a valid link
			flashes 1 time a period	Port is switched to stand-by
			flashes 3 times a period	Port is switched off
DA	Data traffic	yellow	flashing	Device is transmitting and/or receiving data

## 1.6 Management interfaces

### 1.6.1 V.24 interface (external management)

The V.24 interface is an RJ11 socket.

The V.24 user interface is serial and allows you to connect the following devices directly:

- ▶ External management station (VT100 terminal or PC with appropriate terminal emulation). With this management station, the Command Line Interface (CLI) is available to you. Furthermore, the system monitor is available to you at the system start.
- ▶ The AutoConfiguration Adapter ACA11

#### VT100 terminal settings

Speed	9600 Baud
Data	8 bit
Stopbit	1 bit
Handshake	off
Parity	none

The interface casing is electrically connected to the front panel.  
The V.24 interface is not electrically isolated from the supply voltage.

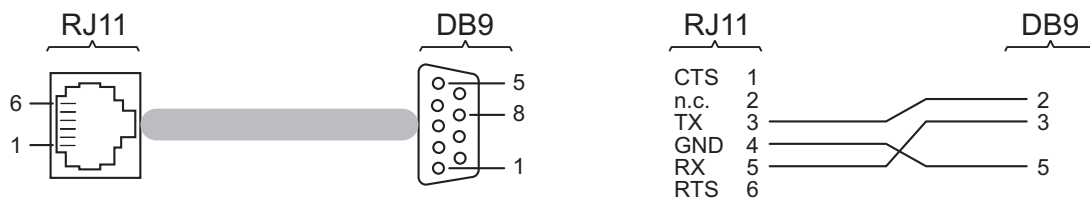

Figure 8: Pin assignment of the V.24 interface and the DB9 plug

You will find the order number for the terminal cable, which is ordered separately, in the Technical Data section ([see on page 37 “Technical data”](#)).

## 1.6.2 USB interface

The USB interface allows you to connect the AutoConfiguration Adapter ACA21-USB (EEC) storage medium. This is used for saving/loading the configuration data and diagnostic information, and for loading the software. See “Accessories and order numbers” on page 44.

Figure	Pin	Function
	1	VCC (VBus)
	2	- Data
	3	+ Data
	4	Ground (GND)

Table 3: Pin assignment of the USB interface

## 1.7 Signal contact

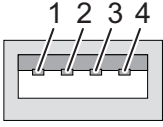
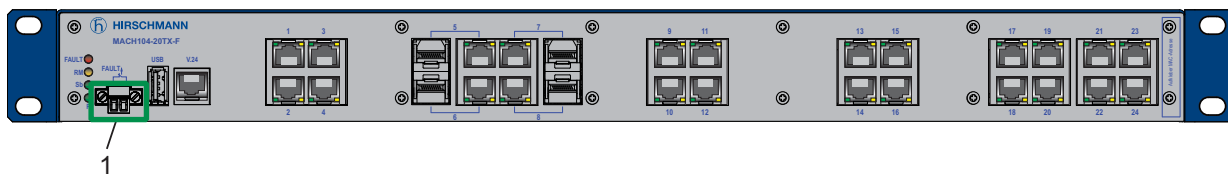

Figure 9: MACH104 device, front view  
1 - Signal contact

The signal contact is a potential-free relay contact. The signal contact is open when the device is not connected to a power supply.

The signal contact allows you to control external devices or monitor device functions.

In the configuration, you specify how the device uses the signal contact. You find detailed information regarding possible applications and configuration of the signal contact in the software user documentation on the Hirschmann product pages ([www.hirschmann.com](http://www.hirschmann.com)).

## 2 Installation

On delivery, the device is ready for operation.

The following procedure has been proven to be successful for the assembly of the device:

- ▶ [Checking the package contents](#)
- ▶ [Installing an SFP transceiver \(optional\)](#)
- ▶ [Wiring and installing the signal contact](#)
- ▶ [Installing the device and grounding](#)
- ▶ [Operating the device](#)
- ▶ [Connecting data cables](#)

**Note:** Note the safety instructions in [“Requirements for connecting electrical wires”](#) on page 6.

### 2.1 Checking the package contents

- Check whether the package includes all items named in the section [“Scope of delivery, order numbers and accessories”](#) on page 44.
- Check the individual parts for transport damage.

### 2.2 Installing an SFP transceiver (optional)

#### Prerequisites:

Exclusively use Hirschmann SFP transceivers.

See [“Accessories and order numbers”](#) on page 44.

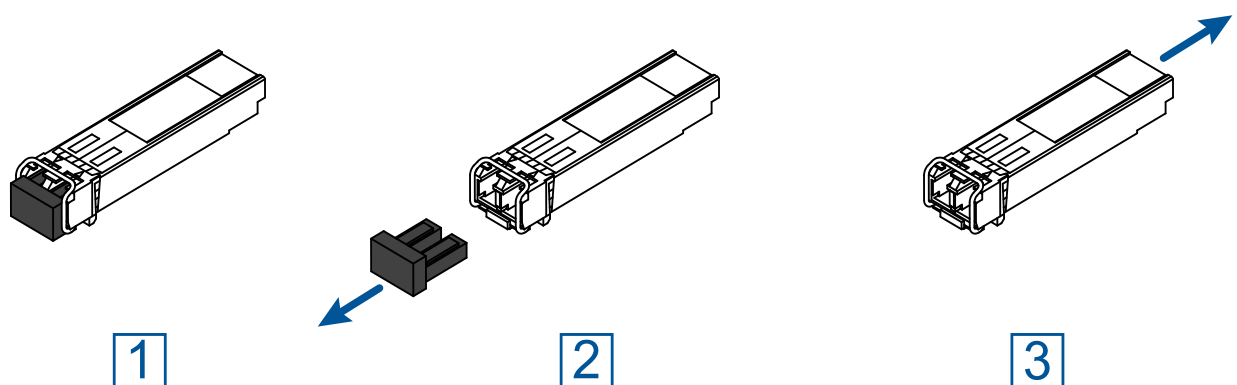

Figure 10: Installing SFP transceivers: Installation sequence

### Proceed as follows:

- Take the SFP transceiver out of the transport packaging (1).
- Remove the protection cap from the SFP transceiver (2).
- Push the SFP transceiver with the lock closed into the slot until it latches in (3).

## 2.3 Wiring and installing the signal contact

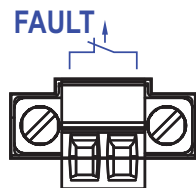

Figure 11: 2-pin terminal block

### **WARNING**

#### **ELECTRIC SHOCK**

Never insert sharp objects (small screwdrivers, wires, or similar items) into the connection terminals for the signal lines, and do not touch the terminals.

**Failure to follow these instructions can result in death, serious injury, or equipment damage.**

**Every** time you connect the electrical conductors, make sure that the following requirements are met:

- ▶ The electrical wires are voltage-free.
- ▶ The connected voltage is limited by a current limitation device or a fuse. Observe the electrical threshold values for the signal contact.  
[See “General technical data” on page 37.](#)
- Remove the terminal connector from the device.
- Connect the signal contact lines with the terminal block connections.
- Mount the terminal block for the signal contact on the front of the device using the screw lock. Check whether the terminal block is correctly plugged and screwed on.

You find the prescribed tightening torque in chapter:  
[“General technical data” on page 37](#)

## 2.4 Installing the device and grounding

The device can be mounted on a flat surface, in a 19" standard switch cabinet, or on the wall.

### 2.4.1 Selecting the assembly location

Select the assembly location according to the safety guidelines ([see on page 5 "Safety instructions"](#)).

When selecting the assembly location, also make sure the following requirements are met:

- The assembly location can be accessed for maintenance and repair work.
- The LED display elements are clearly visible.
- Twisted pair cables are at a sufficient distance from potential sources of electrical interference, such as power supply cables.
- The device has a separate power source with a ground connection. The power supply can be interrupted by means of a separate isolator or power switch. We recommend using overvoltage protection for all devices.

### 2.4.2 Mounting on a flat surface

Before operating the device on a flat surface, such as a table, stick the supplied casing feet onto the bottom of the device, with approx. 0.8 in (2 cm) of space from the corners.

- If necessary, remove any dirt from the bottom of the device where you want to place the stick-on feet.
- Remove the protective foil from the adhesive surface of a casing foot and attach the casing foot on the device.

### 2.4.3 Mounting in a switch cabinet

**Note:** Note the instructions on installations in 19" switch cabinets according to UL 60950-1.

[See "Relevant for installations in switch cabinets according to UL 60950-1" on page 12.](#)

**Note:** For more information on sliding/mounting rails and how to install them, please contact your switch cabinet manufacturer.

The devices are designed to be mounted in a 19" switch cabinet.

- Ensure adequate ventilation. If necessary, install an additional fan in the switch cabinet to prevent the device from overheating.
- Measure the depth of the 19" switch cabinet so as to allow the power supply cables to be fitted at the back and the data cables to be fitted at the front.
- Assemble the sliding or mounting rails in the 19" switch cabinet as specified by the manufacturer.

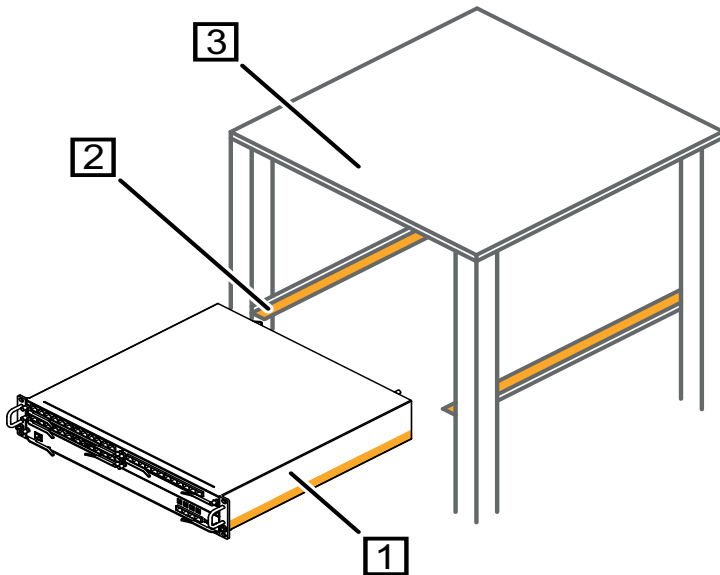

Figure 12: Assembly in a switch cabinet with sliding/mounting rails

- 1 - MACH104 device
- 2 - sliding/mounting rail
- 3 - 19" switch cabinet



Figure 13: Mounting the MACH104 in the 19" cabinet

- Fasten the device by screwing the brackets to the switch cabinet.

**Note:** When operating the device in an environment with strong vibrations, you have the option to additionally fasten the device to the switch cabinet using 2 holding brackets on the back of the device. You obtain the additional brackets as accessories. See [“Accessories and order numbers” on page 44.](#)

#### 2.4.4 Mounting on the wall

- Remove the screws on the pre-installed mounting brackets.
- Move the two pre-installed mounting brackets into the position shown below.
- Use the screws to secure the mounting brackets on the device.

- Additionally attach 2 brackets to the back of the device.  
See [figure 14](#).  
You obtain the additional brackets as accessories.  
See [“Accessories and order numbers”](#) on page 44.
- Fasten the device by screwing the brackets to the wall.

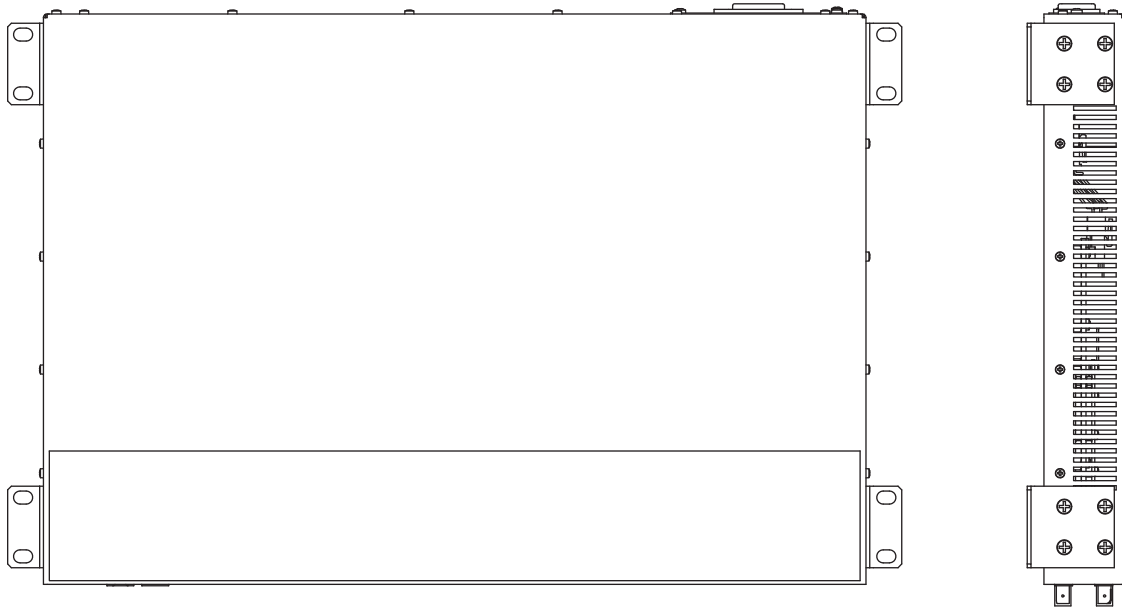

*Figure 14: Vertical mounting on the wall*

### **2.4.5 Grounding the device**

The device is grounded via the power supply connections.

## 2.5 Operating the device



### WARNING

#### ELECTRIC SHOCK

Connect only a supply voltage that corresponds to the type plate of your device.

**Failure to follow these instructions can result in death, serious injury, or equipment damage.**

**Note:** Note the safety instructions in [“Requirements for connecting electrical wires”](#) on page 6.

By connecting the voltage supply via the voltage supply socket(s), you start the operation of the device.

## 2.6 Connecting data cables

**Note:** Verify that you connect only optical ports with the same optical transmission properties with each other.

Further information:

See [“Ethernet ports”](#) on page 20.

Connect the data cables according to your requirements.

### 3 Making basic settings

**Note:** Two or more devices configured with the same IP address can cause unpredictable operation of your network.

Install and maintain a process that assigns a unique IP address to every device in the network.

When you install the device for the first time enter the IP parameters.

The device provides the following options for entering the IP parameters during the first installation:

- ▶ Configuration via DHCP (state on delivery)
- ▶ Input via the V.24 interface
- ▶ Input via the HiView or Industrial HiVision application. You find further information about the applications HiView or Industrial HiVision on the Internet at the Hirschmann product pages:

**HiView**

<http://www.hirschmann.com/en/QR/INET-HiView>

**Industrial HiVision**

<http://www.hirschmann.com/en/QR/INET-Industrial-HiVision>

- ▶ Configuration via BOOTP
- ▶ Configuration via DHCP (Option 82)
- ▶ AutoConfiguration Adapter

Further information on the basic settings of the device can be found in the “Basic Configuration” user manual.

### **3.1 Default settings**

- ▶ The device looks for the IP address using DHCP
- ▶ Management password:  
user, password: public (read only)  
admin, password: private (read and write)
- ▶ V.24 data rate: 9600 Baud
- ▶ Ring redundancy disabled
- ▶ Ethernet ports: link status is not evaluated (signal contact)
- ▶ Optical 100 Mbit/s ports: 100 Mbit/s full duplex  
Other ports: Autonegotiation
- ▶ Redundancy manager disabled  
(DIP switch RM and Standby: ON)
- ▶ Standby coupling disabled  
(DIP switch RM and Standby: ON)  
Port 3 = control port, Port 4 = coupling port for redundant ring coupling
- ▶ Rapid Spanning Tree enabled

## 4 Maintenance and service

- When designing this device, Hirschmann largely avoided using high-wear parts. The parts subject to wear and tear are dimensioned to last longer than the lifetime of the product when it is operated normally. Operate this device according to the specifications.  
[See “Technical data” on page 37.](#)
- Relays are subject to natural wear. This wear depends on the frequency of the switching operations. Check the resistance of the closed relay contacts and the switching function depending on the frequency of the switching operations.
- Hirschmann is continually working on improving and developing their software. Check regularly whether there is an updated version of the software that provides you with additional benefits. You find information and software downloads on the Hirschmann product pages on the Internet (<http://www.hirschmann.com>).
- Internal fuses are triggered only in the case of a detected error in the device. In case of damage or malfunction of the device, turn off the supply voltage and return the device to the plant for inspection.
- Depending on the degree of pollution in the operating environment, check at regular intervals that the ventilation slots in the device are not obstructed.

**Note:** You find information on settling complaints on the Internet at <http://www.beldensolutions.com/en/Service/Repairs/index.phtml>.

# 5 Deinstallation

## 5.1 Removing the device

- Disconnect the data cables.
- Disable the supply voltage.
- Disconnect the supply voltage.
- Remove the terminal connector from the device.
- To detach the device from the switch cabinet or the wall, remove the screws from the brackets on the device.

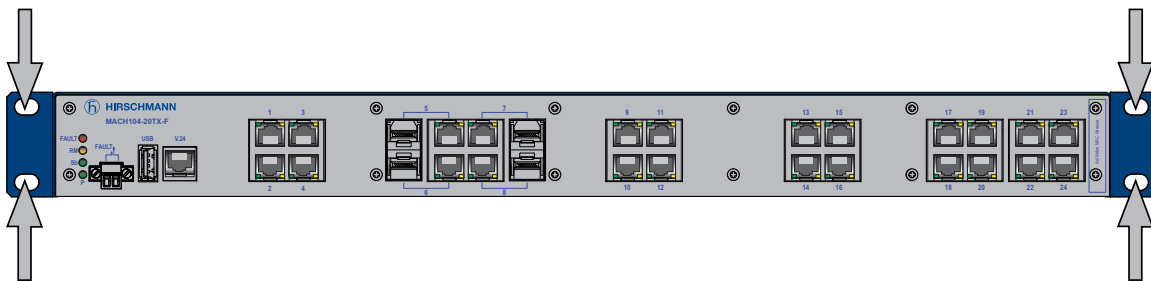

Figure 15: Disassembling the device

## 5.2 Removing an SFP transceiver (optional)

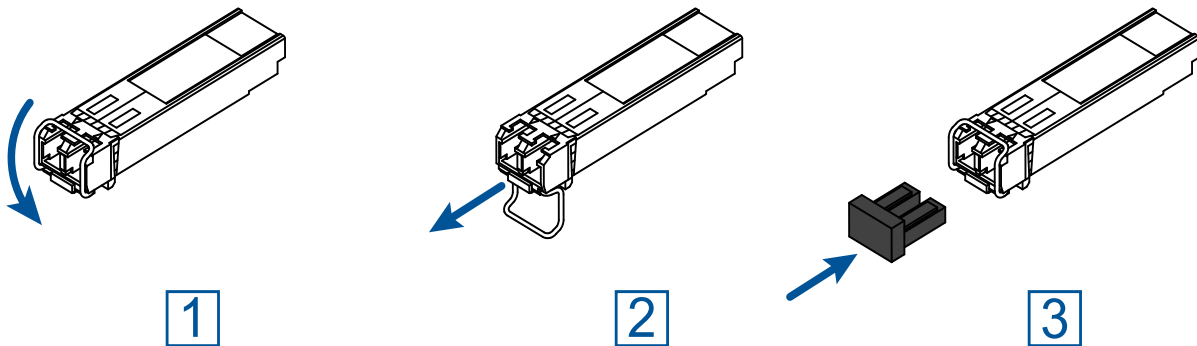

Figure 16: De-installing SFP transceivers: De-installation sequence

### Proceed as follows:

- Open the locking mechanism of the SFP transceiver (1).
- Pull the SFP transceiver out of the slot via the open locking mechanism (2).
- Close the SFP transceiver with the protection cap (3).

# 6 Technical data

## 6.1 General technical data

Dimensions	See "Dimension drawings" on page 38.	
Weight	MACH104-20TX-F...	9.26 lb (4.2 kg)
	MACH104-20TX-FR...	9.7 lb (4.4 kg)
	MACH104-20TX-F-4-PoE...	10.14 lb (4.6 kg)
Supply voltage	Rated voltage range	100 V AC ... 240 V AC, 50 Hz ... 60 Hz
	Voltage range including maximum tolerances	90 V AC ... 265 V AC, 47 Hz ... 63 Hz
Current consumption	Rated current for devices without PoE	max. 0.3 A (240 V AC) max. 0.5 A (100 V AC)
	Rated current for devices with PoE	max. 0.9 A (240 V AC) max. 1.7 A (100 V AC)
	Activation current	typ. < 40 A at 265 V AC and cold start
PoE power	Maximum number of Powered Devices (PDs)	This applies to the following device variants only: MACH104-20TX-F-4-PoE... 4 × Powered Device (PD) Class 0 (15.4 W)
Power loss buffer		> 12 ms (115 V AC)
Overload current protection at input	Non-replaceable fuse	
Climatic conditions during operation	Ambient air temperature <sup>a</sup>	+32 °F ... +122 °F (0 °C ... +50 °C)
	Humidity	20 % ... 90 % (non-condensing)
	Air pressure	min. 795 hPa (+6562 ft; +2000 m) max. 1060 hPa (-1312 ft; -400 m)
Climatic conditions during storage	Ambient air temperature <sup>b</sup>	-4 °F ... +185 °F (-20 °C ... +85 °C)
	Humidity	10 % ... 95 % (non-condensing)
	Air pressure	min. 700 hPa (+9842 ft; +3000 m) max. 1060 hPa (-1312 ft; -400 m)
Signal contact	Switching current	max. 1 A, SELV
	Switching voltage	max. 60 V DC or max. 30 V AC, SELV
	Connection type	2-pin terminal block
		max. conductor cross section AWG16 (1.3 mm <sup>2</sup> ) Tightening torque 2.2 lb-in (0.25 Nm)
Pollution degree	2	
Protection classes	Laser protection	Class 1 in compliance with IEC 60825-1
	Degree of protection	IP30

- a. Temperature of the ambient air at a distance of 2 in (5 cm) from the device  
b. Temperature of the ambient air at a distance of 2 in (5 cm) from the device

## 6.2 Dimension drawings

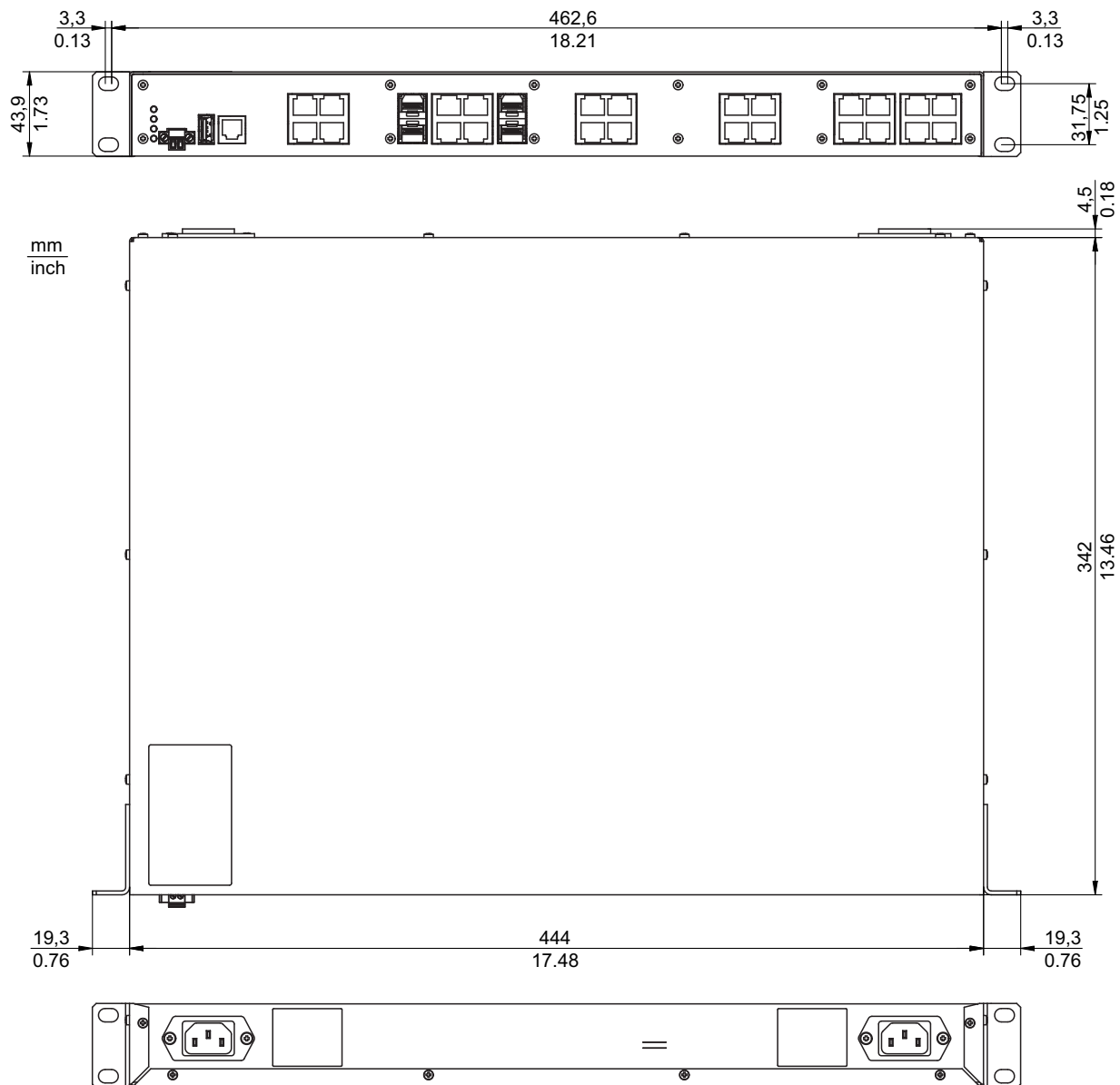

## 6.3 EMC and immunity

### EMC interference immunity

IEC/EN 61000-4-2	Electrostatic discharge	
	Contact discharge	6 kV
	Air discharge	8 kV
IEC/EN 61000-4-3	Electromagnetic field	
	80 MHz ... 3000 MHz	max. 20 V/m
IEC/EN 61000-4-4	Fast transients (burst)	
	Power line	2 kV
	Data line	4 kV

**EMC interference immunity**

IEC/EN 61000-4-5	Voltage surges	
	Power line, line / line	1 kV
	Power line, line / ground	2 kV
	Data line	4 kV
IEC/EN 61000-4-6	Conducted disturbances	
	150 kHz ... 80 MHz	10 V
EN 61000-4-9	Pulse magnetic fields	300 A/m

**EMC interference emission**

EN 55032	Class A	Yes
FCC 47 CFR Part 15	Class A	Yes

## 6.4 Network range

**Note:** The line lengths specified for the transceivers apply for the respective fiber data (fiber attenuation and Bandwidth Length Product (BLP)/ Dispersion).

### 10/100/1000 Mbit/s twisted pair port

Length of a twisted pair segment                      max. 328 ft (100 m) (for Cat5e cable)

Table 4: Network range: 10/100/1000 Mbit/s twisted pair port

Product code M-FAST-SFP-...	Mode <sup>a</sup>	Wave length	Fiber	System attenuation	Example for F/O cable length <sup>b</sup>	Fiber attenuation	BLP/Dispersion
-MM/LC...	MM	1310 nm	50/125 μm	0 dB ... 8 dB	0 mi ... 3.11 mi (0 km ... 5 km)	1.0 dB/km	800 MHz×km
-MM/LC...	MM	1310 nm	62.5/125 μm	0 dB ... 11 dB	0 mi ... 2.49 mi (0 km ... 4 km)	1.0 dB/km	500 MHz×km
-SM/LC...	SM	1310 nm	9/125 μm	0 dB ... 13 dB	0 mi ... 15.53 mi (0 km ... 25 km)	0.4 dB/km	3.5 ps/(nm×km)
-SM+/LC...	SM	1310 nm	9/125 μm	10 dB ... 29 dB	15.53 mi ... 40.39 mi (25 km ... 65 km)	0.4 dB/km	3.5 ps/(nm×km)
-LH/LC...	SM	1550 nm	9/125 μm	10 dB ... 29 dB	29.20 mi ... 64.62 mi (47 km ... 104 km)	0.25 dB/km	19 ps/(nm×km)
-LH/LC...	SM	1550 nm	9/125 μm	10 dB ... 29 dB	14.29 mi ... 86.99 mi (55 km ... 140 km)	0.18 dB/km <sup>c</sup>	18 ps/(nm×km)

Table 5: Fiber port 100BASE-FX (SFP fiber optic Fast Ethernet Transceiver)

- MM = Multimode, SM = Singlemode, LH = Singlemode Longhaul
- Including 3 dB system reserve when compliance with the fiber data is observed.
- With ultra-low-loss optical fiber.

Product code M-SFP-...	Mode <sup>a</sup>	Wave length	Fiber	System attenuation	Example for F/O cable length <sup>b</sup>	Fiber attenuation	BLP <sup>c</sup> /Dispersion
-SX/LC...	MM	850 nm	50/125 μm	0 dB ... 7.5 dB	0 mi ... 0.34 mi (0 km ... 0.55 km)	3.0 dB/km	400 MHz×km
-SX/LC...	MM	850 nm	62.5/125 μm	0 dB ... 7.5 dB	0 mi ... 0.17 mi (0 km ... 0.275 km)	3.2 dB/km	200 MHz×km
-MX/LC...	MM	1310 nm	50/125 μm	0 dB ... 12 dB	0 km ... 1.5 km	1.0 dB/km	800 MHz×km
-MX/LC...	MM	1310 nm	62.5/125 μm	0 dB ... 12 dB	0 mi ... 31.06 mi (0 km ... 50 km)	1.0 dB/km	500 MHz×km
-LX/LC...	MM	1310 nm <sup>d</sup>	50/125 μm	0 dB ... 10.5 dB	0 mi ... 0.34 mi (0 km ... 0.55 km)	1.0 dB/km	800 MHz×km
-LX/LC...	MM	1310 nm <sup>e</sup>	62.5/125 μm	0 dB ... 10.5 dB	0 mi ... 0.34 mi (0 km ... 0.55 km)	1.0 dB/km	500 MHz×km
-LX/LC...	SM	1310 nm	9/125 μm	0 dB ... 10.5 dB	0 mi ... 12.43 mi (0 km ... 20 km) <sup>f</sup>	0.4 dB/km	3.5 ps/(nm×km)
-LX+/LC...	SM	1310 nm	9/125 μm	5 dB ... 20 dB	8.70 mi ... 26.10 mi (14 km ... 42 km)	0.4 dB/km	3.5 ps/(nm×km)
-LH/LC...	LH	1550 nm	9/125 μm	5 dB ... 22 dB	14.29 mi ... 49.71 mi (23 km ... 80 km)	0.25 dB/km	19 ps/(nm×km)
-LH+/LC	LH	1550 nm	9/125 μm	15 dB ... 30 dB	44.12 mi ... 67.11 mi (71 km ... 108 km)	0.25 dB/km	19 ps/(nm×km)
-LH+/LC	LH	1550 nm	9/125 μm	15 dB ... 30 dB	44.12 mi ... 79.54 mi (71 km ... 128 km)	0.21 dB/km (typically)	19 ps/(nm×km)

**Table 6: F/O port 1000BASE-FX (SFP fiber optic Gigabit Ethernet Transceiver)**

- a. MM = Multimode, SM = Singlemode, LH = Singlemode Longhaul
- b. Including 3 dB system reserve when compliance with the fiber data is observed.
- c. Using the bandwidth-length product is inappropriate for expansion calculations.
- d. With F/O adapter compliant with IEEE 802.3-2002 Clause 38 (single-mode fiber offset-launch mode conditioning patch cord).
- e. With F/O adapter compliant with IEEE 802.3-2002 Clause 38 (single-mode fiber offset-launch mode conditioning patch cord).
- f. Including 2.5 dB system reserve when compliance with the fiber data is observed.

Product code M-SFP-BIDI...	Mode <sup>a</sup>	Wave length TX	Wave length RX	Fiber	System attenuation	Example for F/O cable length <sup>b</sup>	Fiber attenuation	Dispersion
Type A LX/LC EEC	SM	1310 nm	1550 nm	9/125 μm	0 dB ... 11 dB	0 km ... 12.43 mi (0 km ... 20 km)	0.4 dB/km	3.5 ps/(nm×km)
Type B LX/LC EEC	SM	1550 nm	1310 nm	9/125 μm	0 dB ... 11 dB	0 mi ... 12.43 mi (0 km ... 20 km)	0.25 dB/km	19 ps/(nm×km)
Type A LH/LC EEC	LH	1490 nm	1590 nm	9/125 μm	5 dB ... 24 dB	14.29 mi ... 49.71 mi (23 km ... 80 km)	0.25 dB/km	19 ps/(nm×km)
Type B LH/LC EEC	LH	1590 nm	1490 nm	9/125 μm	5 dB ... 24 dB	14.29 mi ... 49.71 mi (23 km ... 80 km)	0.25 dB/km	19 ps/(nm×km)

*Table 7: F/O port (bidirectional Gigabit Ethernet SFP transceiver)*

- a. MM = Multimode, SM = Singlemode, LH = Singlemode Longhaul  
b. Including 3 dB system reserve when compliance with the fiber data is observed.

## 6.5 Power consumption/power output

<b>MACH104device</b>	<b>Maximum power consumption</b>	<b>Maximum power output</b>
MACH104-20TX-F...	35 W	119 Btu (IT)/h
MACH104-20TX-FR...	35 W	119 Btu (IT)/h
MACH104-20TX-F-4-PoE..., with 4 × Class 0 Powered-Device connected	110 W	170 Btu (IT)/h

## 7 Scope of delivery, order numbers and accessories

### ■ MACH104-20TX-F...

Number	Article
1 ×	General safety instructions
1 ×	Device
1 ×	2-pin terminal block for signal contact
2 ×	Brackets with fastening screws (pre-mounted)
1 ×	Casing feet, stick on
1 ×	Non-heating appliance cable (Euro model)

### ■ MACH104-20TX-FR...

Number	Article
1 ×	General safety instructions
1 ×	Device
1 ×	2-pin terminal block for signal contact
2 ×	Brackets with fastening screws (pre-mounted)
1 ×	Casing feet, stick on
2 ×	Non-heating appliance cable (Euro model)

### ■ MACH104-20TX-F-4-PoE...

Number	Article
1 ×	General safety instructions
1 ×	Device
1 ×	2-pin terminal block for signal contact
2 ×	Brackets with fastening screws (pre-mounted)
1 ×	Casing feet, stick on
1 ×	Non-heating appliance cable (Euro model)

### ■ Accessories and order numbers

**Note:** Note that products recommended as accessories may have characteristics that do not fully correspond to those of the respective product. This may limit their possible usage in the overall system.

MACH104device	Order number
MACH104-20TX-F-L2P	942 003-001
MACH104-20TX-FR-L2P	942 003-101
MACH104-20TX-F-4-PoE-L2P	942 003-201
MACH104-20TX-F-L3P	942 003-002
MACH104-20TX-FR-L3P	942 003-102
MACH104-20TX-F-4-PoE-L3P	942 003-202

Name	Order number
AutoConfiguration AdapterACA21-USB (EEC)	943 271-003
AutoConfiguration AdapterACA11	943 751-001
Terminal cable	943 301-001
2-pin terminal block (50 pieces)	943 845-010
Bracket for fastening the casing	943 943-001
Bracket, long (+ 1.97 in (50 mm)), for fastening the casing (extra)	943 943-101
Network management software Industrial HiVision	943 156-xxx
OPC Server software HiOPC	943 055-001

Gigabit Ethernet SFP transceiver	Order number
M-SFP-TX/RJ45	943 977-001
M-SFP-TX/RJ45 EEC	942 161-001

The following operating conditions apply to twisted pair transceivers:

- ▶ Usable with:
  - HiOS as of software version 03.0.00
  - Classic Switch software, as of software version 04.1.00.
  - HiSecOS as of software version 01.2.00
- Do not use with the following devices:
  - SPIDER II- MSP/MSM
  - EES
- ▶ Longer RSTP switching times and link loss detection times compared to twisted pair ports provided by the device directly.
- ▶ Not applicable for combo and Fast Ethernet ports.
- ▶ Only support of the autonegotiation mode including autocrossing.

M-SFP-SX/LC	943 014-001
M-SFP-SX/LC EEC	943 896-001
M-SFP-MX/LC EEC	942 108-001
M-SFP-LX/LC	943 015-001
M-SFP-LX/LC EEC	943 897-001
M-SFP-LX+/LC	942 023-001
M-SFP-LX+/ LC EEC	942 024-001
M-SFP-LH/LC	943 042-001
M-SFP-LH/LC EEC	943 898-001
M-SFP-LH+/LC	943 049-001
M-SFP-LH+/LC EEC	942 119-001
SFP-GIG-LX/LC <sup>a</sup>	942 196-001
SFP-GIG-LX/LC EEC <sup>a</sup>	942 196-002

- a. You find further information on certifications on the Internet at the Hirschmann product pages ([www.hirschmann.com](http://www.hirschmann.com)).

<b>Fast Ethernet SFP transceiver</b>	<b>Order number</b>
M-FAST SFP-TX/RJ45	942 098-001
M-FAST SFP-TX/RJ45 EEC	942 098-002

The following operating conditions apply to twisted pair transceivers:

- ▶ Usable with:
  - HiOS as of software version 03.0.00
  - for PRP ports on RSP devices, as of software version 02.0.01
  - for PRP ports on EES devices, as of software version 02.0.02
  - Classic switch software as of software version 08.0.00
  - HiSecOS as of software version 01.2.00
- ▶ Longer RSTP switching times and link loss detection times compared to twisted pair ports provided by the device directly.
- ▶ Not applicable for combo ports.
- ▶ Not applicable for ports which support only Gigabit Ethernet.
- ▶ To set autocrossing manually is currently not possible.

M-FAST SFP-MM/LC	943 865-001
M-FAST SFP-MM/LC EEC	943 945-001
M-FAST SFP-SM/LC	943 866-001
M-FAST SFP-SM/LC EEC	943 946-001
M-FAST SFP-SM+/LC	943 867-001
M-FAST SFP-SM+/LC EEC	943 947-001
M-FAST SFP-LH/LC	943 868-001
M-FAST SFP-LH/LC EEC	943 948-001
SFP-FAST-MM/LC <sup>a</sup>	942 194-001
SFP-FAST-MM/LC EEC <sup>a</sup>	942 194-002
SFP-FAST-SM/LC <sup>a</sup>	942 195-001
SFP-FAST-SM/LC EEC <sup>a</sup>	942 195-002

a. You find further information on certifications on the Internet at the Hirschmann product pages ([www.hirschmann.com](http://www.hirschmann.com)).

<b>Bidirectional Gigabit Ethernet SFP transceiver</b>	<b>Order number</b>
M-SFP-BIDI Type A LX/LC EEC	943 974-001
M-SFP-BIDI Type B LX/LC EEC	943 974-002
M-SFP-BIDI Type A LH/LC EEC	943 975-001
M-SFP-BIDI Type B LH/LC EEC	943 975-002
M-SFP-BIDI Bundle LX/LC EEC (type A + B)	943 974-101
M-SFP-BIDI Bundle LH/LC EEC (type A + B)	943 975-101

## 8 Underlying technical standards

Name	
CSA 22.2 No. 60950-1	Information Technology Equipment – Safety – Part 1: General Requirements
EN 61000-6-2	Electromagnetic compatibility (EMC) – Part 6-2: Generic standards – Immunity for industrial environments
EN 55032	Electromagnetic compatibility of multimedia equipment – Emission Requirements
FCC 47 CFR Part 15	Code of Federal Regulations
EN 60950-1	Information technology equipment – Safety – Part 1: General requirements
IEEE 802.1D	MAC Bridges (switching function)
IEEE 802.1Q	Virtual LANs (VLANs, MRP, Spanning Tree)
IEEE 802.1w	Rapid Reconfiguration
IEEE 802.3	Ethernet
UL 60950-1	Information technology equipment – Safety – Part 1: General requirements

*Table 8: List of the technical standards*

The device generally fulfills the technical standards named in their current versions.

The device has an approval based on a specific standard exclusively if the approval indicator appears on the device casing.

If your device has a shipping approval according to Germanischer Lloyd or DNV GL, you find the respective approval mark printed on the device label. You will find out whether your device has other shipping approvals on the Hirschmann website under [www.hirschmann.com](http://www.hirschmann.com) in the product information.

# A Further support

## Technical questions

For technical questions, please contact any Hirschmann dealer in your area or Hirschmann directly.

You find the addresses of our partners on the Internet at <http://www.hirschmann.com>.

A list of local telephone numbers and email addresses for technical support directly from Hirschmann is available at <https://hirschmann-support.belden.com>.

This site also includes a free of charge knowledge base and a software download section.

## Hirschmann Competence Center

The Hirschmann Competence Center is ahead of its competitors on three counts with its complete range of innovative services:

- ▶ Consulting incorporates comprehensive technical advice, from system evaluation through network planning to project planning.
- ▶ Training offers you an introduction to the basics, product briefing and user training with certification.  
You find the training courses on technology and products currently available at <http://www.hicomcenter.com>.
- ▶ Support ranges from the first installation through the standby service to maintenance concepts.

With the Hirschmann Competence Center, you decided against making any compromises. Our client-customized package leaves you free to choose the service components you want to use.

Internet:

<http://www.hicomcenter.com>





**HIRSCHMANN**

---

A **BELDEN** BRAND