

Discontinued

3-phase Motor

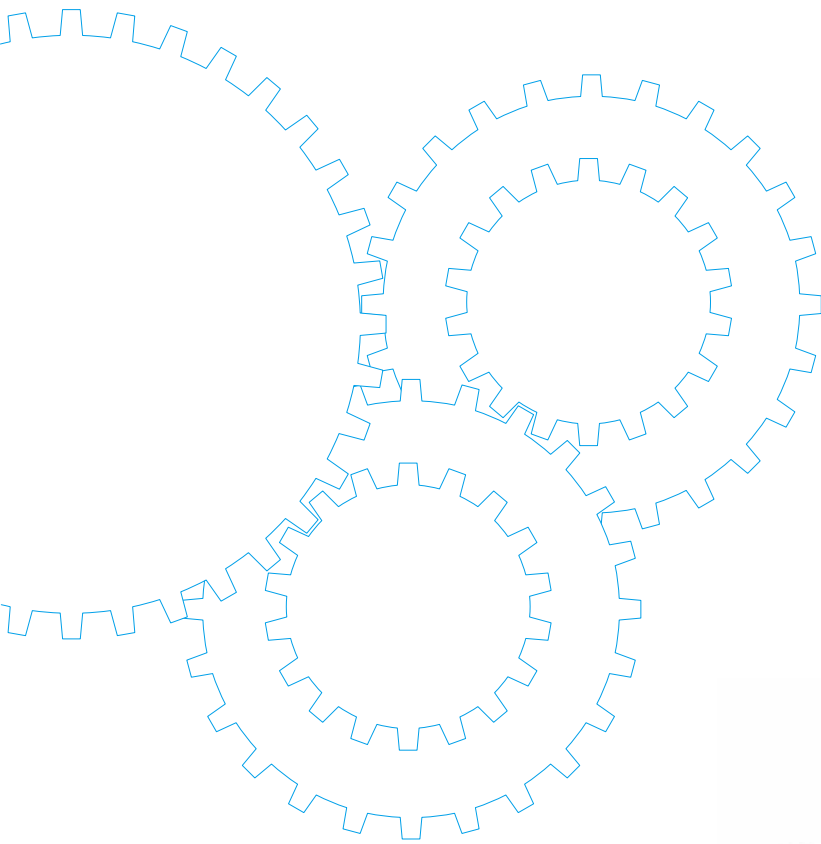

Contents

- Motor Overview B-126
- Model list B-128
- Product information for each model B-130
- Gear head combination dimensions B-162
- Round shaft motor dimensions B-164

Outline of 3-phase motor

Features

- The 3-phase motor is an induction motor for 3-phase power.
- Continuous time rating
- The motor with national specifications is of heatproof class 120 (E); the motor with specifications compliant with overseas standards is of heatproof class 130 (B).

Note) 3-phase motor start-stop operation must not exceed 6-cycles per minute or damage may occur.

Construction

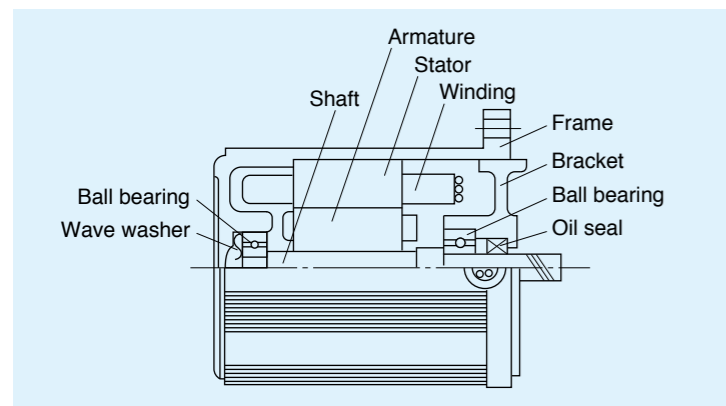

Characteristics

Speed-torque characteristics

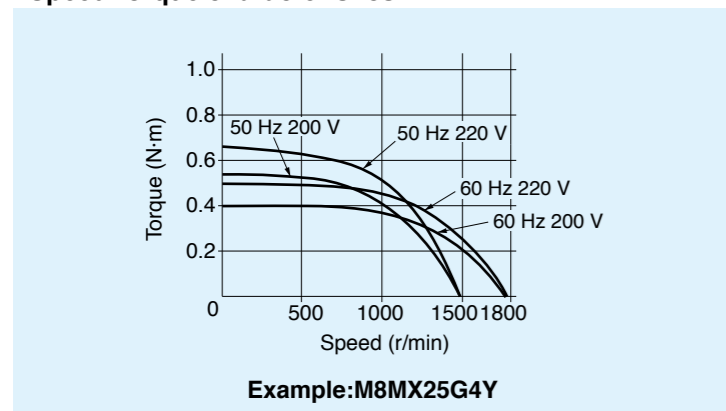

System configuration diagram

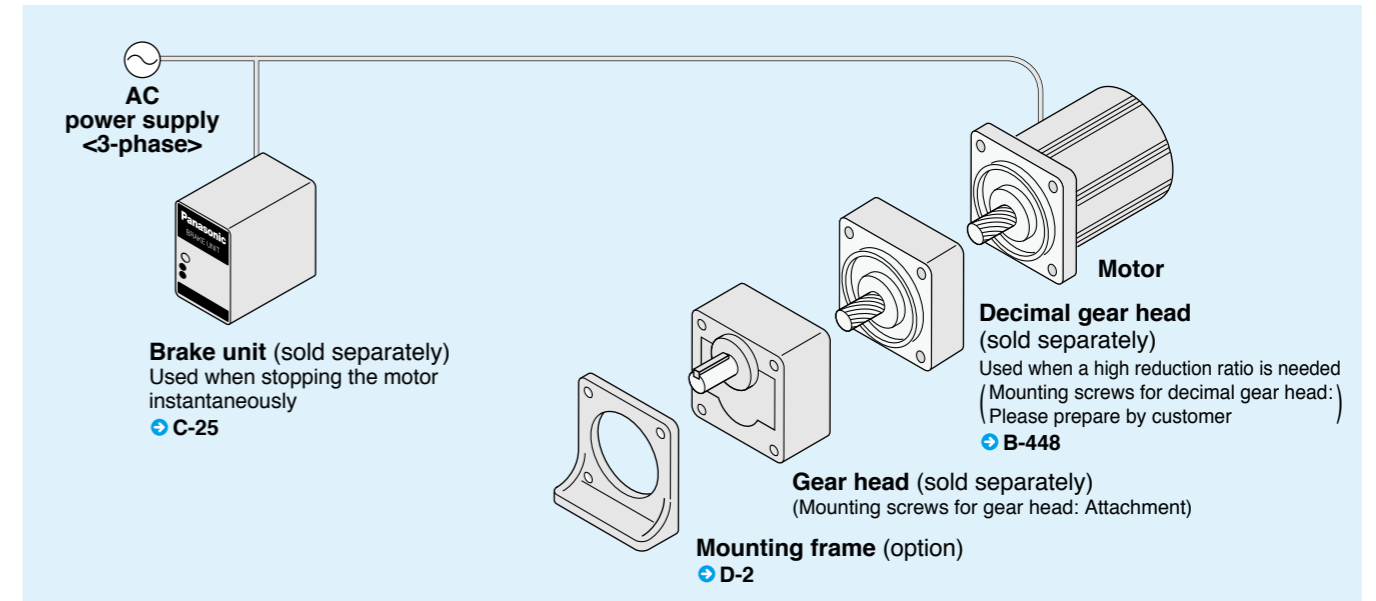

Coding system

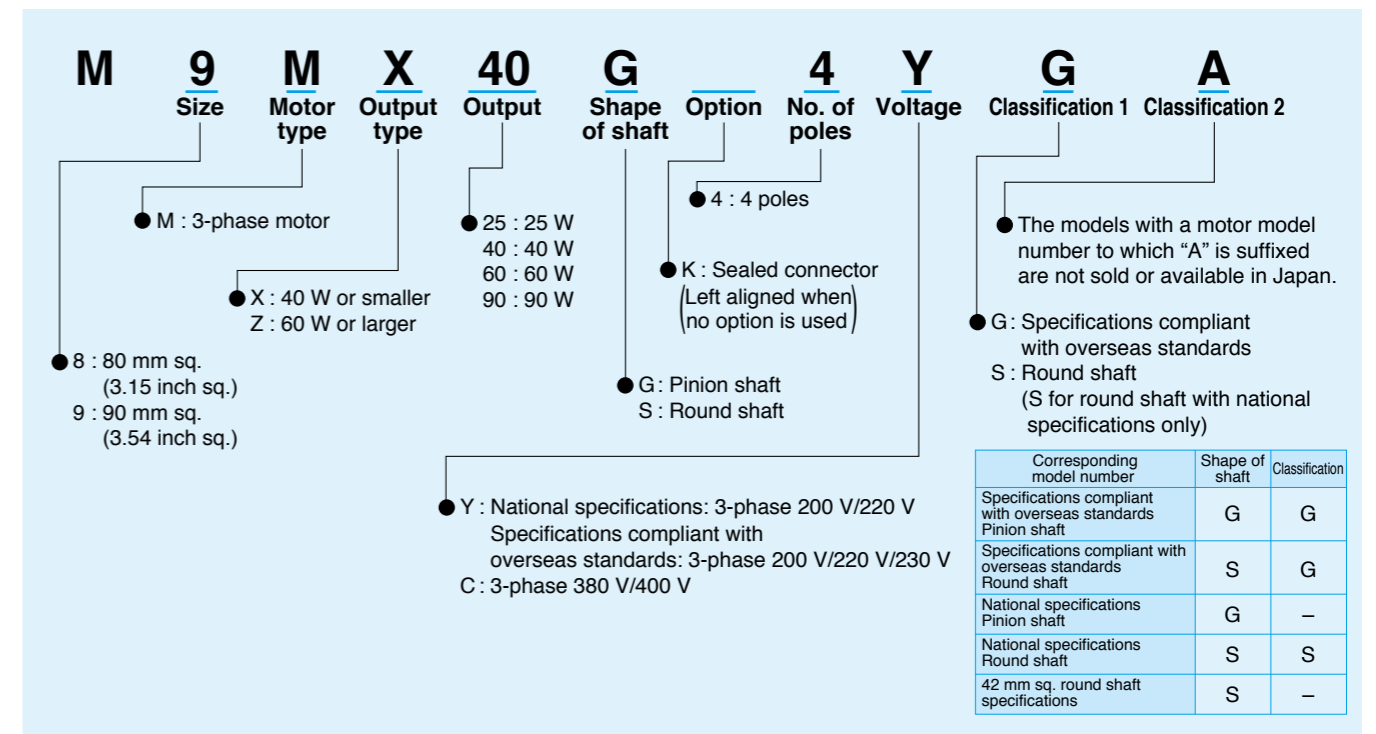





Fit tolerance

Fit tolerance symbol is used in the outside dimension diagram of motor and gear head. For further information, see "Fit tolerance" on page A-33.

Model list of 3-phase motor

Pinion shaft motor

★ Motor compliant with overseas standards e Motor compliant with China efficiency standards c    

Size	Output (W)	Leadwire type			Sealed connector type		
		Model number	Specifications	Page	Model number	Specifications	Page
80 mm sq. (3.15 inch sq.)	25	M8MX25G4Y	200 V/220 V	B-130	M8MX25GK4Y	200 V/220 V	B-146
		M8MX25G4YG(A)	200 V/220 V/230 V ★	B-132	M8MX25GK4YG(A)	200 V/220 V/230 V ★	B-148
					M8MX25GK4CG(A)	380 V/400 V ★ e	B-148
90 mm sq. (3.54 inch sq.)	40	M9MX40G4Y	200 V/220 V	B-134	M9MX40GK4Y	200 V/220 V	B-150
		M9MX40G4YG(A)	200 V/220 V/230 V ★	B-136	M9MX40GK4YG(A)	200 V/220 V/230 V ★	B-152
					M9MX40GK4CG(A)	380 V/400 V ★ e	B-152
	60	M9MZ60G4Y	200 V/220 V	B-138	M9MZ60GK4Y	200 V/220 V	B-154
		M9MZ60G4YG(A)	200 V/220 V/230 V ★	B-140	M9MZ60GK4YG(A)	200 V/220 V/230 V ★	B-156
					M9MZ60GK4CG(A)	380 V/400 V ★ e	B-156
90	M9MZ90G4Y	200 V/220 V	B-142	M9MZ90GK4Y	200 V/220 V	B-158	
	M9MZ90G4YG(A)	200 V/220 V/230 V ★	B-144	M9MZ90GK4YG(A)	200 V/220 V/230 V ★	B-160	
				M9MZ90GK4CG(A)	380 V/400 V ★ e	B-160	





Applicable gear head









Standard gear head		High torque gear head	Right-angle gear head	Gear head -Inch (U.S.A.)	Decimal gear head
Ball bearing	metal bearing				
MX8G□B	MX8G□M	—	—	MX9G□BU	MX8G10XB
MX9G□B	MX9G□M	—	MX9G□R	MX9G□BU	MX9G10XB
MZ9G□B	—	MR9G□B	MZ9G□R	MZ9G□BU	MZ9G10XB
MY9G□B	—	MP9G□B			

 Hinge attached

* Refer to page B-444 for dimensions and permissible torque of high torque gear head.
 Refer to page B-446 for dimensions and permissible torque of right-angle gear head.
 Refer to page B-451 for dimensions and permissible torque of gear head -Inch (U.S.A.).
 Refer to page B-448 for dimensions of decimal gear head.

Round shaft motor

★ Motor compliant with overseas standards e Motor compliant with China efficiency standards c    
 Ⓢ Electrical Appliance and Material Safety Law

Size	Output (W)	Leadwire type		Sealed connector type	
		Model number	Specifications	Model number	Specifications
80 mm sq. (3.15 inch sq.)	25	M8MX25S4YS	200 V/220 V	M8MX25SK4YS	200 V/220 V 
		M8MX25S4YG(A)	200 V/220 V/230 V ★	M8MX25SK4YG(A)	200 V/220 V/230 V ★ 
				M8MX25SK4CG(A)	380 V/400 V ★ e
90 mm sq. (3.54 inch sq.)	40	M9MX40S4YS	200 V/220 V	M9MX40SK4YS	200 V/220 V 
		M9MX40S4YG(A)	200 V/220 V/230 V ★	M9MX40SK4YG(A)	200 V/220 V/230 V ★ 
				M9MX40SK4CG(A)	380 V/400 V ★ e
	60	M9MZ60S4YS	200 V/220 V	M9MZ60SK4YS	200 V/220 V 
		M9MZ60S4YG(A)	200 V/220 V/230 V ★	M9MZ60SK4YG(A)	200 V/220 V/230 V ★ 
				M9MZ60SK4CG(A)	380 V/400 V ★ e
90	M9MZ90S4YS	200 V/220 V	M9MZ90SK4YS	200 V/220 V 	
	M9MZ90S4YG(A)	200 V/220 V/230 V ★	M9MZ90SK4YG(A)	200 V/220 V/230 V ★ 	
			M9MZ90SK4CG(A)	380 V/400 V ★ e	

* The specifications and wire connections of the round shaft motor are the same as those of the pinion shaft motor.
 Dimensional outline drawing → Page B-164.

<Notice>

380 V/400 V 3-phase round shaft motors with a sealed connector are not covered by the Electrical Appliance and Material Safety Law.

3-phase motor (leadwire)

80 mm (3.15 inch) sq. 25 W

Specifications

Size	Motor model No.	Number of pole (P)	Output (W)	Voltage (V)	Frequency (Hz)	Rating (min)	Rating				Starting current (A)	Starting torque N-m (oz-in)
							Input (W)	Current (A)	Speed (r/min)	Torque N-m (oz-in)		
80 mm sq.	M8MX25G4YG M8MX25G4YGA	4	25	200	50	Cont.	50	0.25	1350	0.18 (25.5)	0.62	0.54 (76.5)
							47	0.22	1625	0.15 (21.2)	0.58	0.40 (56.6)
							49	0.23	1650	0.14 (19.8)	0.64	0.50 (70.8)
							50	0.24	1675	0.14 (19.8)	0.65	0.54 (76.5)

• The specifications and wire connections of the round shaft motor are the same as those of the pinion shaft type. For the dimensional outline drawing, refer to page B-164.
 • The models with a motor model number to which "A" is suffixed are not sold or available in Japan.
 • For the combination of motor and gearhead, refer to pages B-128 and B-129 of applicable gearheads in the model list.

Permissible torque at output shaft of gear head

* The speed shown below is a calculated value based on the synchronous rotational speed. Depending on the load, the speed is less than the indicated value by 2% to 20%.

Unit of permissible torque: upper (N·m) / lower (lb·in)

Reduction ratio	Unit of permissible torque: upper (N·m) / lower (lb·in)																							
	3	3.6	5	6	7.5	9	10	12.5	15	18	20	25	30	36	50	60	75	90	100	120	150	180		
Speed (r/min)	50 Hz	500	416.7	300	250	200	166.7	150	120	100	83.3	75	60	50	41.7	30	25	20	16.7	15	12.5	10	8.3	
	60 Hz	600	500	360	300	240	200	180	144	120	100	90	72	60	50	36	30	24	20	18	15	12	10	
Applicable gear head	MX8G3B to MX8G180B (ball bearing)	50 Hz	0.39 (3.45)	0.47 (4.16)	0.66 (5.84)	0.78 (6.90)	0.98 (8.67)	1.18 (10.4)	1.27 (11.2)	1.57 (13.9)	1.96 (17.3)	2.35 (20.8)	2.55 (22.6)	3.14 (27.8)	3.82 (33.8)	4.61 (40.8)	6.37 (56.4)	7.64 (67.6)						7.84 (69.4)
		60 Hz	0.32 (2.83)	0.39 (3.45)	0.55 (4.87)	0.66 (5.84)	0.81 (7.17)	0.98 (8.67)	1.08 (9.56)	1.27 (11.2)	1.57 (13.9)	1.96 (17.3)	2.06 (18.2)	2.65 (23.5)	3.14 (27.8)	3.82 (33.8)	5.29 (46.8)	6.37 (56.4)						7.84 (69.4)
Rotational direction		Same as motor rotational direction											Reverse to motor rotational direction											

Permissible torque at output shaft of gear head using decimal gear head

* For external dimensions of the decimal gear head, refer to page B-448.

Applicable gear head		Reduction ratio	Permissible torque													
Bearing	Decimal gear head		Speed (r/min)	50 Hz	200	250	300	360	500	600	750	900	1000	1200	1500	1800
MX8G□B (ball bearing) MX8G□M (metal bearing)	MX8G10XB	50 Hz	7.5	7.5	6	5	4.2	3	2.5	2	1.7	1.5	1.3	1	0.8	
		60 Hz	9	7.2	6	5	3.6	3	2.4	2	1.8	1.5	1.2	1		
Rotational direction		Same as motor rotational direction			Reverse to motor rotational direction											

Connection diagram

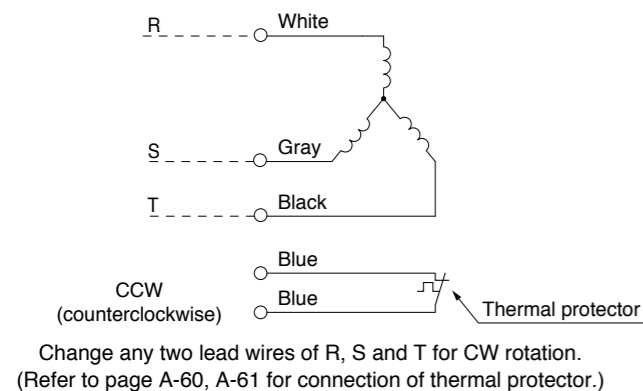

Speed-torque characteristics

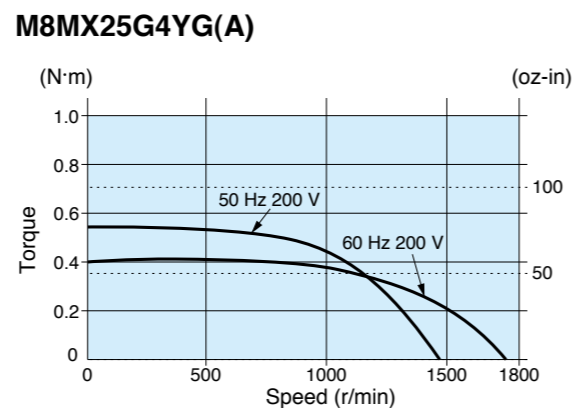

* Please read your User's manual carefully so that you will understand the operation and safety precautions before attempting to operate the system.

[Features B-126](#)
[System configuration B-127](#)
[Coding system B-127](#)
[Model list B-128](#)

Motor (dimensions)

M8MX25G4Y(G) 4P 25 W 200 V / 220 V / 230 V

Scale: 1/3, Unit: mm (inch)

Mass 1.5 kg 3.31 lb
 Helical gear
 Module 0.5
 Number of teeth 9

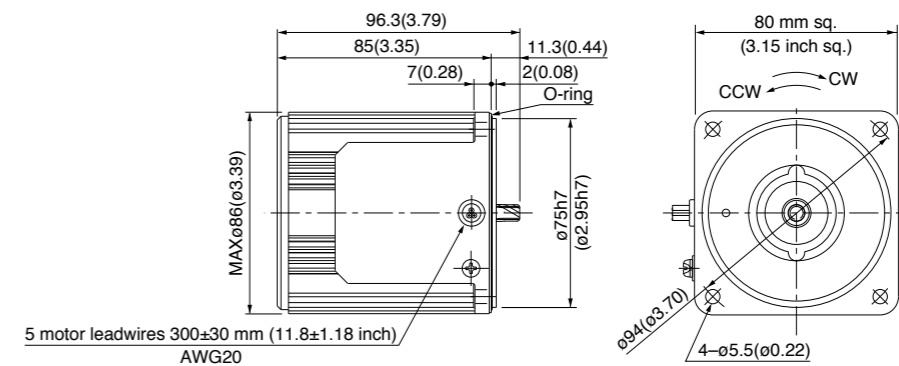

Gear head (dimensions)

Scale: 1/3, Unit: mm (inch)

MX8G□B (ball bearing) Mass 0.6 kg(1.32 lb) MX8G□M (metal bearing) Mass 0.6 kg(1.32 lb)

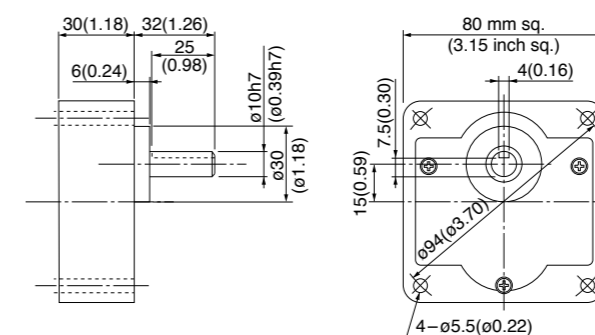

Key and keyway (dimensions) [attachment]

MX8G□B(M)

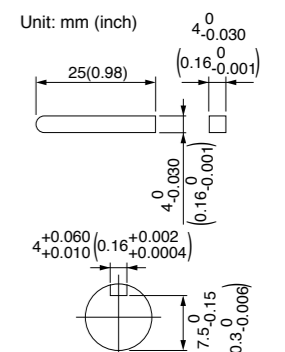

(Note) Because the dimensions may be subject to change, also check the determinate dimensions if the gear head is to be used for design.

[Gear head combination B-162](#)
[Round shaft motor B-164](#)
[Decimal gear head B-448](#)
[Gear head -inch \(U.S.A.\) B-449](#)
[Controls C-4](#)
[Option D-2](#)

Induction motor
 Reversible motor
 3-phase motor
 Electromagnetic brake motor
 Variable speed induction motor
 Variable speed electromagnetic brake single-phase motor
 Variable speed unit motor
 C&B motor
 2-pole round shaft motor
 Gear head
 Gear head -inch (U.S.A.)

3-phase motor (leadwire)

90 mm (3.54 inch) sq. 40 W

Specifications

Size	Motor model No.	Number of pole (P)	Output (W)	Voltage (V)	Frequency (Hz)	Rating (min)	Rating				Starting current (A)	Starting torque N-m (oz-in)
							Input (W)	Current (A)	Speed (r/min)	Torque N-m (oz-in)		
90 mm sq.	M9MX40G4Y	4	40	200	50	Cont.	69	0.31	1350	0.28 (39.7)	0.90	0.72 (102)
					60	Cont.	68	0.29	1625	0.24 (34.0)	0.82	0.51 (72.2)
				220	50	Cont.	70	0.32	1375	0.27 (38.2)	1.0	0.88 (125)
					60	Cont.	66	0.28	1675	0.23 (32.6)	0.91	0.63 (89.2)

The specifications and wire connections of the round shaft motor are the same as those of the pinion shaft type. For the dimensional outline drawing, refer to page B-164. For the combination of motor and gearhead, refer to pages B-128 and B-129 of applicable gearheads in the model list.

Permissible torque at output shaft of gear head

The speed shown below is a calculated value based on the synchronous rotational speed. Depending on the load, the speed is less than the indicated value by 2% to 20%.

Unit of permissible torque: upper (N·m) / lower (lb·in)

Reduction ratio	Unit of permissible torque: upper (N·m) / lower (lb·in)																						
	3	3.6	5	6	7.5	9	10	12.5	15	18	20	25	30	36	50	60	75	90	100	120	150	180	
Speed (r/min)	50 Hz	500	416.7	300	250	200	166.7	150	120	100	83.3	75	60	50	41.7	30	25	20	16.7	15	12.5	10	8.3
	60 Hz	600	500	360	300	240	200	180	144	120	100	90	72	60	50	36	30	24	20	18	15	12	10
Applicable gear head	MX9G3B to MX9G180B (ball bearing)	50 Hz	0.66 (5.84)	0.78 (6.90)	1.08 (9.56)	1.27 (11.2)	1.57 (13.9)	1.86 (16.5)	2.25 (19.9)	2.74 (24.3)	3.23 (28.6)	3.92 (34.7)	4.41 (39.0)	5.29 (46.8)	6.37 (56.4)	7.94 (70.3)	9.80 (86.7)						9.80 (86.7)
	MX9G3M to MX9G180M (metal bearing)	60 Hz	0.55 (4.87)	0.66 (5.84)	0.90 (7.97)	1.08 (9.56)	1.27 (11.2)	1.57 (13.9)	1.76 (15.6)	2.25 (19.9)	2.74 (24.3)	3.23 (28.6)	3.53 (31.2)	4.41 (39.0)	5.29 (46.8)	6.37 (56.4)	8.82 (78.1)						9.80 (86.7)
Rotational direction		Same as motor rotational direction											Reverse to motor rotational direction										

Permissible torque at output shaft of gear head using decimal gear head

For external dimensions of the decimal gear head, refer to page B-448.

Applicable gear head		Reduction ratio	Reduction ratio													
Bearing	Decimal gear head		Speed (r/min)	50 Hz	200	250	300	360	500	600	750	900	1000	1200	1500	1800
MX9G□B (ball bearing) MX9G□M (metal bearing)	MX9G10XB	Permissible torque	N·m (lb-in)	9.80 (86.7)	9.80 (86.7)	9.80 (86.7)	9.80 (86.7)	9.80 (86.7)	9.80 (86.7)	9.80 (86.7)	9.80 (86.7)	9.80 (86.7)	9.80 (86.7)	9.80 (86.7)	9.80 (86.7)	9.80 (86.7)
		Rotational direction		Same as motor rotational direction	Reverse to motor rotational direction											

Refer to page B-446 for the allowable shaft torque of the right-angle shaft type gearhead.

Motor (dimensions)

Scale: 1/3, Unit: mm (inch)

M9MX40G4Y 4P 40 W 200 V / 220 V

Mass 2.4 kg 5.29 lb
Helical gear
Module 0.55
Number of teeth 9

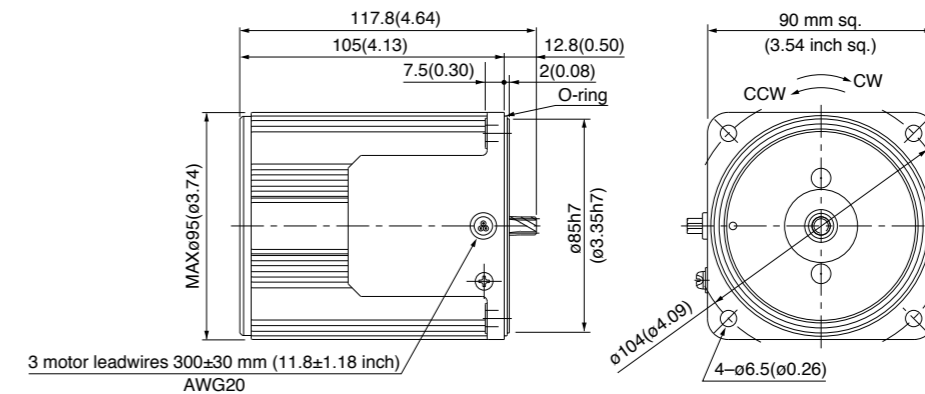

Connection diagram

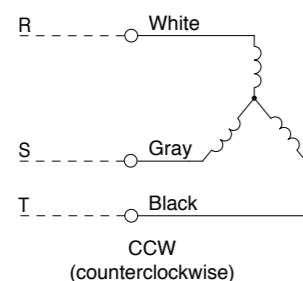

Change any two lead wires of R, S and T for CW rotation.

Speed-torque characteristics

M9MX40G4Y

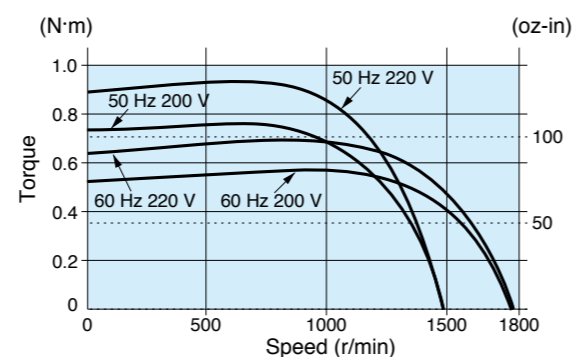

Gear head (dimensions)

Scale: 1/3, Unit: mm (inch)

MX9G□B (ball bearing) Mass 0.8 kg (1.76 lb) MX9G□M (metal bearing) Mass 0.8 kg (1.76 lb)

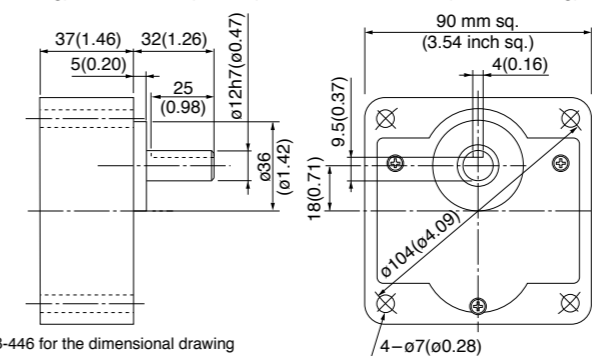

See page B-446 for the dimensional drawing of the right-angle shaft type gearhead.

(Note) Because the dimensions may be subject to change, also check the determinate dimensions if the gear head is to be used for design.

Key and keyway (dimensions) [attachment]

MX9G□B(M)

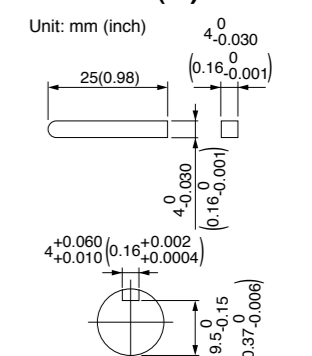

Please read your User's manual carefully so that you will understand the operation and safety precautions before attempting to operate the system.

Features B-126 System configuration B-127 Coding system B-127 Model list B-128

Gear head combination B-162 Round shaft motor B-164 Decimal gear head B-448 Gear head -inch (U.S.A.) B-449 Controls C-4 Option D-2

Induction motor
Reversible motor
3-phase motor
Electromagnetic brake motor
Variable speed induction motor
Variable speed electromagnetic brake single-phase motor
Variable speed unit motor
C&B motor
2-pole round shaft motor
Gear head
Gear head -inch (U.S.A.)

3-phase motor (leadwire)

90 mm (3.54 inch) sq. 40 W

Specifications

Size	Motor model No.	Number of pole (P)	Output (W)	Voltage (V)	Frequency (Hz)	Rating (min)	Rating				Starting current (A)	Starting torque N-m (oz-in)
							Input (W)	Current (A)	Speed (r/min)	Torque N-m (oz-in)		
90 mm sq.	M9MX40G4YG M9MX40G4YGA	4	40	200	50	Cont.	69	0.31	1350	0.28 (39.7)	0.90	0.72 (102)
					60		68	0.29	1625	0.24 (34.0)	0.82	0.51 (72.2)
				220	60		66	0.28	1675	0.23 (32.6)	0.91	0.63 (89.2)
					60		66	0.29	1675	0.23 (32.6)	0.96	0.69 (97.7)

• The specifications and wire connections of the round shaft motor are the same as those of the pinion shaft type. For the dimensional outline drawing, refer to page B-164.
 • The models with a motor model number to which "A" is suffixed are not sold or available in Japan.
 • For the combination of motor and gearhead, refer to pages B-128 and B-129 of applicable gearheads in the model list.

Permissible torque at output shaft of gear head

* The speed shown below is a calculated value based on the synchronous rotational speed. Depending on the load, the speed is less than the indicated value by 2 % to 20 %.

Unit of permissible torque: upper (N·m) / lower (lb·in)

Reduction ratio	Speed (r/min)																						
	3	3.6	5	6	7.5	9	10	12.5	15	18	20	25	30	36	50	60	75	90	100	120	150	180	
Speed (r/min)	50 Hz	500	416.7	300	250	200	166.7	150	120	100	83.3	75	60	50	41.7	30	25	20	16.7	15	12.5	10	8.3
	60 Hz	600	500	360	300	240	200	180	144	120	100	90	72	60	50	36	30	24	20	18	15	12	10
Applicable gear head	MX9G3B to MX9G180B (ball bearing)	50 Hz	0.66 (5.84)	0.78 (6.90)	1.08 (9.56)	1.27 (11.2)	1.57 (13.9)	1.86 (16.5)	2.25 (19.9)	2.74 (24.3)	3.23 (28.6)	3.92 (34.7)	4.41 (39.0)	5.29 (46.8)	6.37 (56.4)	7.94 (70.3)	9.80 (86.7)						
		60 Hz	0.55 (4.87)	0.66 (5.84)	0.90 (7.97)	1.08 (9.56)	1.27 (11.2)	1.57 (13.9)	1.76 (15.6)	2.25 (19.9)	2.74 (24.3)	3.23 (28.6)	3.53 (31.2)	4.41 (39.0)	5.29 (46.8)	6.37 (56.4)	8.82 (78.1)	9.80 (86.7)					
Rotational direction		Same as motor rotational direction											Reverse to motor rotational direction										

Permissible torque at output shaft of gear head using decimal gear head

* For external dimensions of the decimal gear head, refer to page B-448.

Applicable gear head		Reduction ratio	Speed (r/min)													
Bearing	Decimal gear head		50 Hz	60 Hz	200	250	300	360	500	600	750	900	1000	1200	1500	1800
MX9G□B (ball bearing) MX9G□M (metal bearing)	MX9G10XB	Permissible torque	N·m (lb-in)	9.80 (86.7)	9.80 (86.7)	9.80 (86.7)	9.80 (86.7)	9.80 (86.7)	9.80 (86.7)	9.80 (86.7)	9.80 (86.7)	9.80 (86.7)	9.80 (86.7)	9.80 (86.7)	9.80 (86.7)	9.80 (86.7)
		Rotational direction		Same as motor rotational direction			Reverse to motor rotational direction									

Refer to page B-446 for the allowable shaft torque of the right-angle shaft type gearhead.

Connection diagram

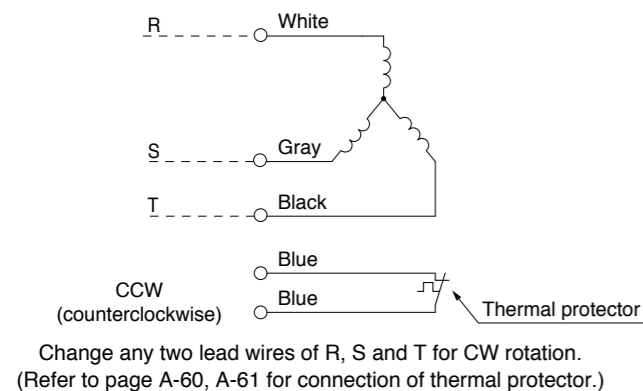

Speed-torque characteristics

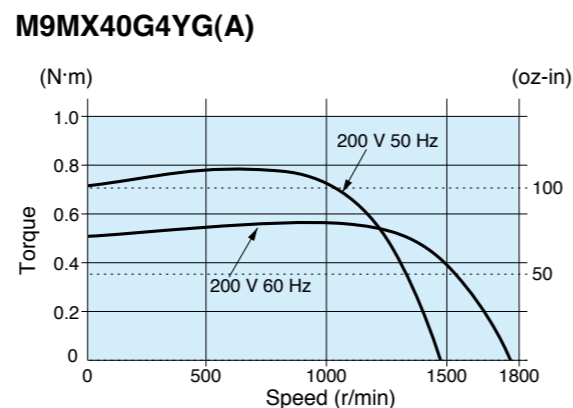

* Please read your User's manual carefully so that you will understand the operation and safety precautions before attempting to operate the system.

[Features B-126](#)
[System configuration B-127](#)
[Coding system B-127](#)
[Model list B-128](#)

Motor (dimensions)

Scale: 1/3, Unit: mm (inch)

M9MX40G4Y(A) 4P 40 W 200 V / 220 V / 230 V

Mass 2.4 kg 5.29 lb
 Helical gear
 Module 0.55
 Number of teeth 9

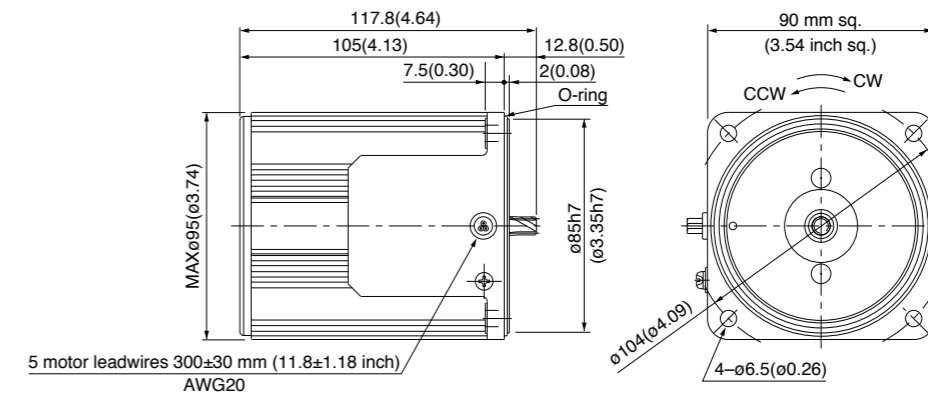

Gear head (dimensions)

Scale: 1/3, Unit: mm (inch)

MX9G□B (ball bearing) Mass 0.8 kg(1.76 lb) MX9G□M (metal bearing) Mass 0.8 kg(1.76 lb)

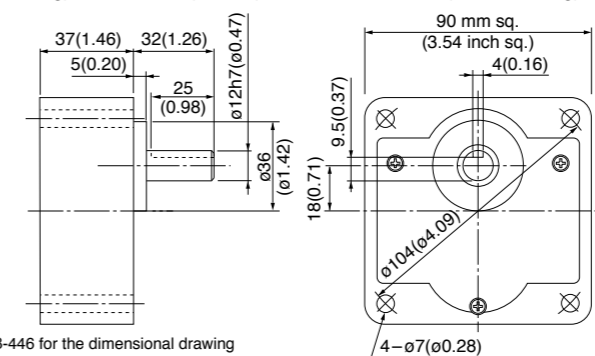

See page B-446 for the dimensional drawing of the right-angle shaft type gearhead.

(Note) Because the dimensions may be subject to change, also check the determinate dimensions if the gear head is to be used for design.

[Gear head combination B-162](#)
[Round shaft motor B-164](#)
[Decimal gear head B-448](#)
[Gear head -inch \(U.S.A.\) B-449](#)
[Controls C-4](#)
[Option D-2](#)

Key and keyway (dimensions) [attachment]

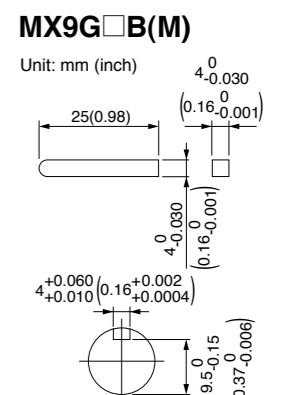

3-phase motor (leadwire)

90 mm (3.54 inch) sq. 60 W

Specifications

Size	Motor model No.	Number of pole (P)	Output (W)	Voltage (V)	Frequency (Hz)	Rating (min)	Rating				Starting current (A)	Starting torque N-m (oz-in)
							Input (W)	Current (A)	Speed (r/min)	Torque N-m (oz-in)		
90 mm sq.	M9MZ60G4Y	4	60	200	50	Cont.	101	0.45	1350	0.42 (59.5)	1.3	1.0 (142)
					60	Cont.	96	0.41	1625	0.35 (49.6)	1.2	0.69 (97.7)
				220	50	Cont.	103	0.46	1375	0.41 (58.1)	1.5	1.2 (170)
					60	Cont.	98	0.40	1650	0.34 (48.1)	1.3	0.87 (123)

The specifications and wire connections of the round shaft motor are the same as those of the pinion shaft type. For the dimensional outline drawing, refer to page B-164.
For the combination of motor and gearhead, refer to pages B-128 and B-129 of applicable gearheads in the model list.

Permissible torque at output shaft of gear head

* The speed shown below is a calculated value based on the synchronous rotational speed. Depending on the load, the speed is less than the indicated value by 2% to 20%.

Unit of permissible torque: upper (N·m) / lower (lb·in)

Reduction ratio	Speed (r/min)																									
	50 Hz	60 Hz	500	416.7	300	250	200	166.7	150	120	100	83.3	75	60	50	41.7	30	25	20	16.7	15	12.5	10	8.3	7.5	
Applicable gear head	MZ9G3B to MZ9G200B (ball bearing / hinge not attached)	50 Hz	0.98 (8.7)	1.18 (10.4)	1.57 (13.9)	1.96 (17.3)	2.35 (20.8)	2.94 (26.0)	3.14 (27.8)	3.92 (34.7)	4.70 (41.6)	5.59 (49.5)	6.27 (55.5)	7.55 (66.8)	9.11 (80.6)	11.0 (97.4)	15.2 (135)	17.8 (158)								19.6 (173)
		60 Hz	0.78 (6.9)	0.98 (8.7)	1.37 (12.1)	1.57 (13.9)	1.96 (17.3)	2.35 (20.8)	2.65 (23.5)	3.33 (29.5)	3.92 (34.7)	4.70 (41.6)	5.29 (46.8)	6.47 (57.3)	7.55 (66.8)	9.11 (80.6)	12.6 (112)	15.2 (135)								19.6 (173)
Rotational direction		Same as motor rotational direction										Reverse to motor rotational direction					Same as motor rotational direction									

Permissible torque at output shaft of gear head using decimal gear head

* For external dimensions of the decimal gear head, refer to page B-448.

Applicable gear head		Reduction ratio	Speed (r/min)															
Bearing	Decimal gear head		50 Hz	60 Hz	250	300	360	500	600	750	900	1000	1200	1500	1800	2000		
MZ9G□B (ball bearing / Hinge not attached) MY9G□B (ball bearing / Hinge attached)	MZ9G10XB	Permissible torque	N·m (lb-in)	19.6 (173)	19.6 (173)	19.6 (173)	19.6 (173)	19.6 (173)	19.6 (173)	19.6 (173)	19.6 (173)	19.6 (173)	19.6 (173)	19.6 (173)	19.6 (173)	19.6 (173)	19.6 (173)	
		Rotational direction		Reverse to motor rotational direction	Same as motor rotational direction													

Refer to pages B-444 and B-445 for the allowable shaft torque of the heavy-duty gearhead.
Refer to page B-446 for the allowable shaft torque of the right-angle shaft type gearhead.

Connection diagram

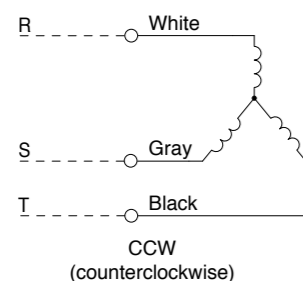

Change any two lead wires of R, S and T for CW rotation.

Speed-torque characteristics

M9MZ60G4Y

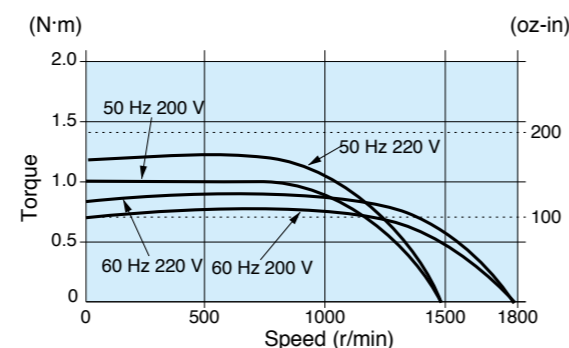

* Please read your User's manual carefully so that you will understand the operation and safety precautions before attempting to operate the system.

Features B-126 System configuration B-127 Coding system B-127 Model list B-128

Motor (dimensions)

Scale: 1/4, Unit: mm (inch)

M9MZ60G4Y 4P 60 W 200 V / 220 V (with fan)

Mass 2.7 kg (5.95 lb)
Helical gear
Module 0.6
Number of teeth 9

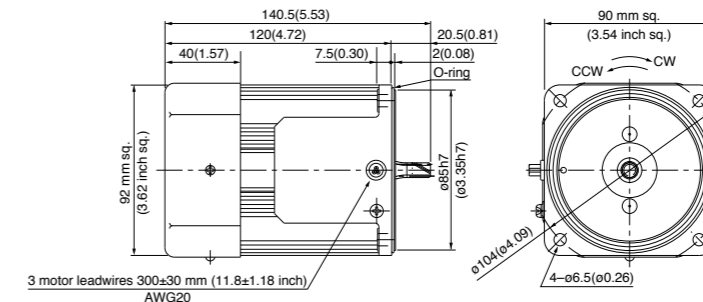

Gear head (dimensions)

Scale: 1/4, Unit: mm (inch)

MZ9G□B (ball bearing / hinge not attached)
Mass 1.4 kg (3.09 lb)

MY9G□B (ball bearing / hinge attached)
Mass 1.4 kg (3.09 lb)

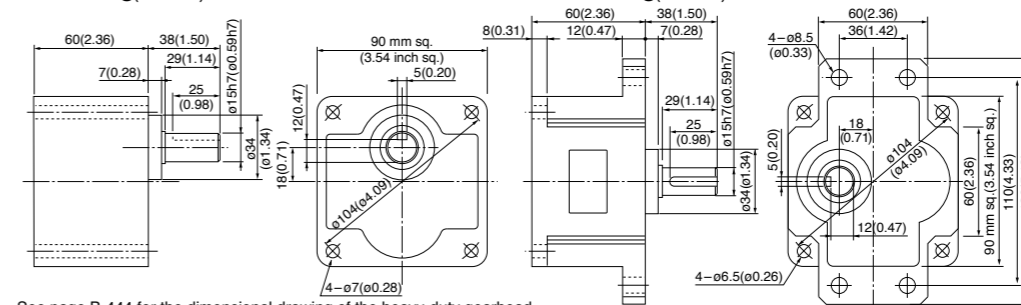

See page B-444 for the dimensional drawing of the heavy-duty gearhead.
See page B-446 for the dimensional drawing of the right-angle shaft type gearhead.

Note) MZ / MY is available for a gear head of either type.

(Note) Because the dimensions may be subject to change, also check the determinate dimensions if the gear head is to be used for design.

Gear head combination B-162 Round shaft motor B-164 Decimal gear head B-448 Gear head -inch (U.S.A.) B-449 Controls C-4 Option D-2

Key and keyway (dimensions) [attachment]

MZ9G□B
MY9G□B

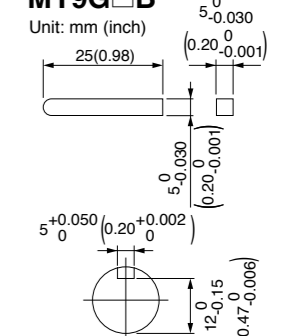

Induction motor
Reversible motor
3-phase motor
Electromagnetic brake motor
Variable speed induction motor
Variable speed electromagnetic brake single-phase motor
Variable speed unit motor
C&B motor
2-pole round shaft motor
Gear head
Gear head -inch (U.S.A.)

3-phase motor (leadwire)

90 mm (3.54 inch) sq. 60 W

Specifications

Size	Motor model No.	Number of pole (P)	Output (W)	Voltage (V)	Frequency (Hz)	Rating (min)	Rating				Starting current (A)	Starting torque N-m (oz-in)
							Input (W)	Current (A)	Speed (r/min)	Torque N-m (oz-in)		
90 mm sq.	M9MZ60G4YG M9MZ60G4YGA	4	60	200	50	Cont.	101	0.45	1350	0.42 (59.5)	1.3	1.0 (142)
							96	0.41	1625	0.35 (49.6)	1.2	0.69 (97.7)
							98	0.40	1650	0.35 (49.6)	1.3	0.87 (123)
							98	0.41	1675	0.34 (48.1)	1.4	1.0 (142)

- The specifications and wire connections of the round shaft motor are the same as those of the pinion shaft type. For the dimensional outline drawing, refer to page B-164.
- The models with a motor model number to which "A" is suffixed are not sold or available in Japan.
- For the combination of motor and gearhead, refer to pages B-128 and B-129 of applicable gearheads in the model list.

Permissible torque at output shaft of gear head

* The speed shown below is a calculated value based on the synchronous rotational speed. Depending on the load, the speed is less than the indicated value by 2% to 20%.

Unit of permissible torque: upper (N·m) / lower (lb·in)

Reduction ratio	Speed (r/min)																									
	50 Hz	60 Hz	500	416.7	300	250	200	166.7	150	120	100	83.3	75	60	50	41.7	30	25	20	16.7	15	12.5	10	8.3	7.5	
Applicable gear head	MZ9G3B to MZ9G200B (ball bearing / hinge not attached)	50 Hz	0.98 (8.7)	1.18 (10.4)	1.57 (13.9)	1.96 (17.3)	2.35 (20.8)	2.94 (26.0)	3.14 (27.8)	3.92 (34.7)	4.70 (41.6)	5.59 (49.5)	6.27 (55.5)	7.55 (66.8)	9.11 (80.6)	11.0 (97.4)	15.2 (135)	17.8 (158)								19.6 (173)
		60 Hz	0.78 (6.9)	0.98 (8.7)	1.37 (12.1)	1.57 (13.9)	1.96 (17.3)	2.35 (20.8)	2.65 (23.5)	3.33 (29.5)	3.92 (34.7)	4.70 (41.6)	5.29 (46.8)	6.47 (57.3)	7.55 (66.8)	9.11 (80.6)	12.6 (112)	15.2 (135)								19.6 (173)
Rotational direction	Same as motor rotational direction										Reverse to motor rotational direction										Same as motor rotational direction					

Permissible torque at output shaft of gear head using decimal gear head

* For external dimensions of the decimal gear head, refer to page B-448.

Applicable gear head		Reduction ratio	Speed (r/min)															
Bearing	Decimal gear head		50 Hz	60 Hz	250	300	360	500	600	750	900	1000	1200	1500	1800	2000		
MZ9G□B (ball bearing / Hinge not attached) MY9G□B (ball bearing / Hinge attached)	MZ9G10XB	Permissible torque	N·m (lb-in)	19.6 (173)	19.6 (173)	19.6 (173)	19.6 (173)	19.6 (173)	19.6 (173)	19.6 (173)	19.6 (173)	19.6 (173)	19.6 (173)	19.6 (173)	19.6 (173)	19.6 (173)	19.6 (173)	
		Rotational direction	Reverse to motor rotational direction			Same as motor rotational direction												

Refer to pages B-444 and B-445 for the allowable shaft torque of the heavy-duty gearhead.
Refer to page B-446 for the allowable shaft torque of the right-angle shaft type gearhead.

Connection diagram

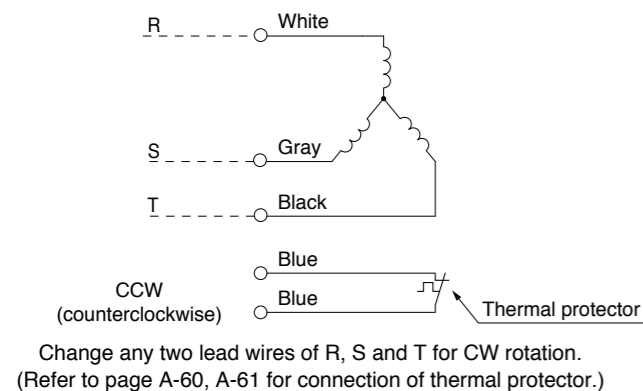

Speed-torque characteristics

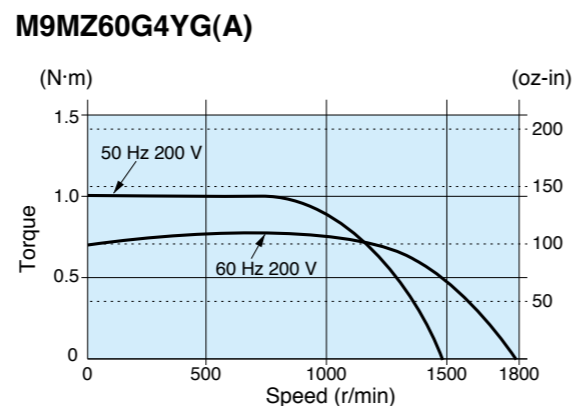

* Please read your User's manual carefully so that you will understand the operation and safety precautions before attempting to operate the system.

[Features B-126](#)
[System configuration B-127](#)
[Coding system B-127](#)
[Model list B-128](#)

Motor (dimensions)

Scale: 1/4, Unit: mm (inch)

M9MZ60G4YG(A) 4P 60 W 200 V / 220 V / 230 V (with fan)

Mass 2.7 kg (5.95 lb)
 Helical gear
 Module 0.6
 Number of teeth 9

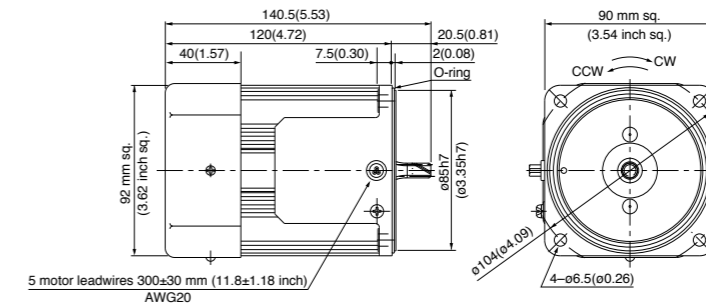

Gear head (dimensions)

Scale: 1/4, Unit: mm (inch)

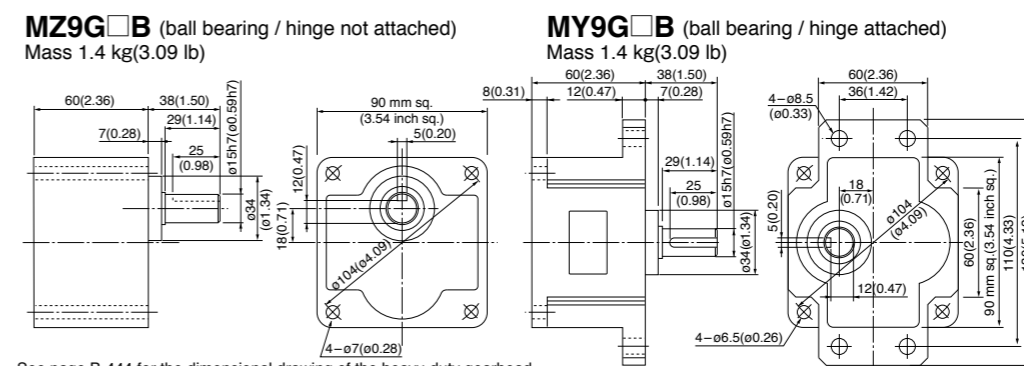

See page B-444 for the dimensional drawing of the heavy-duty gearhead.
See page B-446 for the dimensional drawing of the right-angle shaft type gearhead.

Note) MZ / MY is available for a gear head of either type.
(Note) Because the dimensions may be subject to change, also check the determinate dimensions if the gear head is to be used for design.

[Gear head combination B-162](#)
[Round shaft motor B-164](#)
[Decimal gear head B-448](#)
[Gear head -inch \(U.S.A.\) B-449](#)
[Controls C-4](#)
[Option D-2](#)

Key and keyway (dimensions) [attachment]

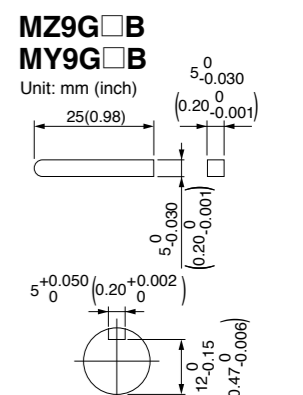

Induction motor
 Reversible motor
 3-phase motor
 Electromagnetic brake motor
 Variable speed induction motor
 Variable speed electromagnetic brake single-phase motor
 Variable speed unit motor
 C&B motor
 2-pole round shaft motor
 Gear head
 Gear head -inch (U.S.A.)

3-phase motor (leadwire)

90 mm (3.54 inch) sq. 90 W

Specifications

Size	Motor model No.	Number of pole (P)	Output (W)	Voltage (V)	Frequency (Hz)	Rating (min)	Rating				Starting current (A)	Starting torque N-m (oz-in)
							Input (W)	Current (A)	Speed (r/min)	Torque N-m (oz-in)		
90 mm sq.	M9MZ90G4Y	4	90	200	50	Cont.	141	0.62	1350	0.63 (89.2)	2.0	1.6 (227)
					60	Cont.	137	0.56	1625	0.53 (75.1)	1.8	1.1 (156)
				220	50	Cont.	143	0.65	1400	0.62 (87.8)	2.2	2.0 (283)
					60	Cont.	137	0.56	1650	0.52 (73.6)	2.0	1.4 (198)

The specifications and wire connections of the round shaft motor are the same as those of the pinion shaft type. For the dimensional outline drawing, refer to page B-164. For the combination of motor and gearhead, refer to pages B-128 and B-129 of applicable gearheads in the model list.

Permissible torque at output shaft of gear head

* The speed shown below is a calculated value based on the synchronous rotational speed. Depending on the load, the speed is less than the indicated value by 2% to 20%.

Unit of permissible torque: upper (N-m) / lower (lb-in)

Reduction ratio	Speed (r/min)																						
	3	3.6	5	6	7.5	9	10	12.5	15	18	20	25	30	36	50	60	75	90	100	120	150	180	200
50 Hz	500	416.7	300	250	200	166.7	150	120	100	83.3	75	60	50	41.7	30	25	20	16.7	15	12.5	10	8.3	7.5
60 Hz	600	500	360	300	240	200	180	144	120	100	90	72	60	50	36	30	24	20	18	15	12	10	9
Applicable gear head	MZ9G3B to MZ9G200B (ball bearing / hinge not attached)	50 Hz	1.37 (12.1)	1.67 (14.8)	2.25 (19.9)	2.74 (24.3)	3.43 (30.4)	4.12 (36.5)	4.51 (39.9)	5.68 (50.3)	6.76 (59.8)	8.04 (71.2)	9.02 (79.8)	10.9 (96.5)	13.0 (115)	15.7 (139)	19.6 (173)						
		60 Hz	1.18 (10.4)	1.37 (12.1)	1.86 (16.5)	2.25 (19.9)	2.84 (25.1)	3.43 (30.4)	3.72 (32.9)	4.70 (41.6)	5.68 (50.3)	6.76 (59.8)	7.55 (66.8)	9.21 (81.5)	10.9 (96.5)	13.0 (115)	18.3 (162)	19.6 (173)					
Rotational direction	Same as motor rotational direction						Reverse to motor rotational direction						Same as motor rotational direction										

Permissible torque at output shaft of gear head using decimal gear head

* For external dimensions of the decimal gear head, refer to page B-448.

Applicable gear head		Reduction ratio	Speed (r/min)															
Bearing	Decimal gear head		50 Hz	300	360	500	600	750	900	1000	1200	1500	1800	2000				
MZ9G□B (ball bearing / hinge not attached)	MZ9G10XB	50 Hz	6	5	4.2	3	2.5	2	1.7	1.5	1.3	1	0.8	0.75				
		60 Hz	7.2	6	5	3.6	3	2.4	2	1.8	1.5	1.2	1	0.9				
MY9G□B (ball bearing / hinge attached)	MZ9G10XB	Permissible torque	N-m (lb-in)	19.6 (173)	19.6 (173)	19.6 (173)	19.6 (173)	19.6 (173)	19.6 (173)	19.6 (173)	19.6 (173)	19.6 (173)	19.6 (173)	19.6 (173)				
Rotational direction		Reverse to motor rotational direction		Same as motor rotational direction														

Refer to pages B-444 and B-445 for the allowable shaft torque of the heavy-duty gearhead. Refer to page B-446 for the allowable shaft torque of the right-angle shaft type gearhead.

Connection diagram

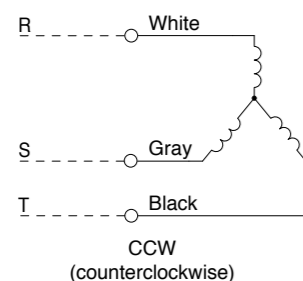

Change any two lead wires of R, S and T for CW rotation.

Speed-torque characteristics

M9MZ90G4Y

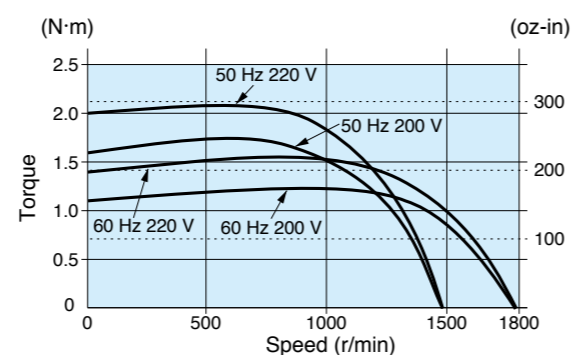

* Please read your User's manual carefully so that you will understand the operation and safety precautions before attempting to operate the system.

- Features B-126
- System configuration B-127
- Coding system B-127
- Model list B-128

Motor (dimensions)

M9MZ90G4Y 4P 90 W 200 V / 220 V (with fan)

Scale: 1/4, Unit: mm (inch)

Mass 3.2 kg (7.05 lb)
Helical gear
Module 0.6
Number of teeth 9

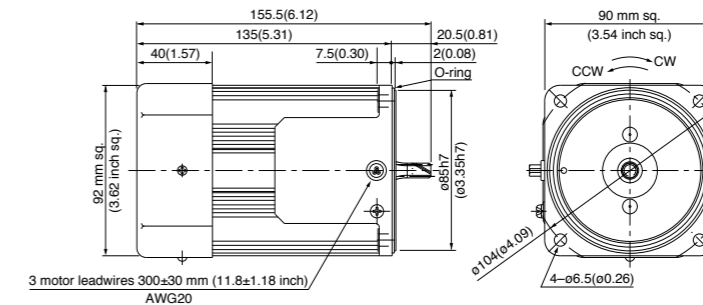

Gear head (dimensions)

Scale: 1/4, Unit: mm (inch)

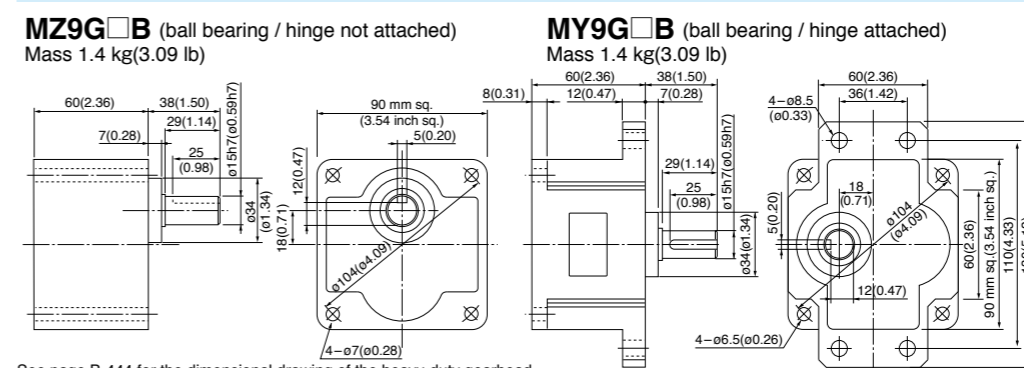

See page B-444 for the dimensional drawing of the heavy-duty gearhead. See page B-446 for the dimensional drawing of the right-angle shaft type gearhead.

Note) MZ / MY is available for a gear head of either type.

(Note) Because the dimensions may be subject to change, also check the determinate dimensions if the gear head is to be used for design.

- Gear head combination B-162
- Round shaft motor B-164
- Decimal gear head B-448
- Gear head -inch (U.S.A.) B-449
- Controls C-4
- Option D-2

Key and keyway (dimensions) [attachment]

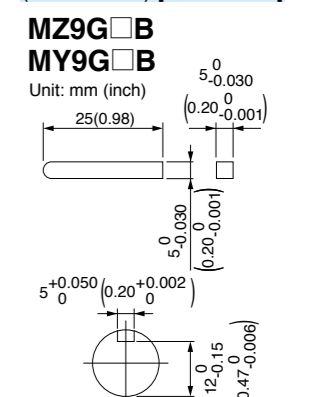

Induction motor
Reversible motor
3-phase motor
Electromagnetic brake motor
Variable speed induction motor
Variable speed electromagnetic brake single-phase motor
Variable speed unit motor
C&B motor
2-pole round shaft motor
Gear head
Gear head -inch (U.S.A.)

3-phase motor (leadwire)

90 mm (3.54 inch) sq. 90 W

Specifications

Size	Motor model No.	Number of pole (P)	Output (W)	Voltage (V)	Frequency (Hz)	Rating (min)	Rating				Starting current (A)	Starting torque N-m (oz-in)
							Input (W)	Current (A)	Speed (r/min)	Torque N-m (oz-in)		
90 mm sq.	M9MZ90G4YG M9MZ90G4YGA	4	90	200	50	Cont.	142	0.62	1350	0.63 (89.2)	2.0	1.6 (227)
							138	0.56	1625	0.53 (75.1)	1.8	1.1 (156)
							137	0.56	1650	0.52 (73.6)	2.0	1.4 (198)
							137	0.58	1675	0.51 (72.2)	2.1	1.6 (227)

- The specifications and wire connections of the round shaft motor are the same as those of the pinion shaft type. For the dimensional outline drawing, refer to page B-164.
- The models with a motor model number to which "A" is suffixed are not sold or available in Japan.
- For the combination of motor and gearhead, refer to pages B-128 and B-129 of applicable gearheads in the model list.

Permissible torque at output shaft of gear head

* The speed shown below is a calculated value based on the synchronous rotational speed. Depending on the load, the speed is less than the indicated value by 2% to 20%.

Unit of permissible torque: upper (N·m) / lower (lb·in)

Reduction ratio	Speed (r/min)																										
	50 Hz	60 Hz	500	416.7	300	250	200	166.7	150	120	100	83.3	75	60	50	41.7	30	25	20	16.7	15	12.5	10	8.3	7.5		
Applicable gear head	MZ9G3B to MZ9G200B (ball bearing / hinge not attached)	50 Hz	1.37 (12.1)	1.67 (14.8)	2.25 (19.9)	2.74 (24.3)	3.43 (30.4)	4.12 (36.5)	4.51 (39.9)	5.68 (50.3)	6.76 (59.8)	8.04 (71.2)	9.02 (79.8)	10.9 (96.5)	13.0 (115)	15.7 (139)	19.6 (173)										
		60 Hz	1.18 (10.4)	1.37 (12.1)	1.86 (16.5)	2.25 (19.9)	2.84 (25.1)	3.43 (30.4)	3.72 (32.9)	4.70 (41.6)	5.68 (50.3)	6.76 (59.8)	7.55 (66.8)	9.21 (81.5)	10.9 (96.5)	13.0 (115)	18.3 (162)	19.6 (173)									
Rotational direction	Same as motor rotational direction										Reverse to motor rotational direction																

Permissible torque at output shaft of gear head using decimal gear head

* For external dimensions of the decimal gear head, refer to page B-448.

Applicable gear head		Reduction ratio	Speed (r/min)															
Bearing	Decimal gear head		50 Hz	60 Hz	250	300	360	500	600	750	900	1000	1200	1500	1800	2000		
MZ9G□B (ball bearing / hinge not attached) MY9G□B (ball bearing / hinge attached)	MZ9G10XB	Permissible torque	N·m (lb-in)	19.6 (173)	19.6 (173)	19.6 (173)	19.6 (173)	19.6 (173)	19.6 (173)	19.6 (173)	19.6 (173)	19.6 (173)	19.6 (173)	19.6 (173)	19.6 (173)	19.6 (200)		
		Rotational direction	Reverse to motor rotational direction			Same as motor rotational direction												

Refer to pages B-444 and B-445 for the allowable shaft torque of the heavy-duty gearhead.
Refer to page B-446 for the allowable shaft torque of the right-angle shaft type gearhead.

Connection diagram

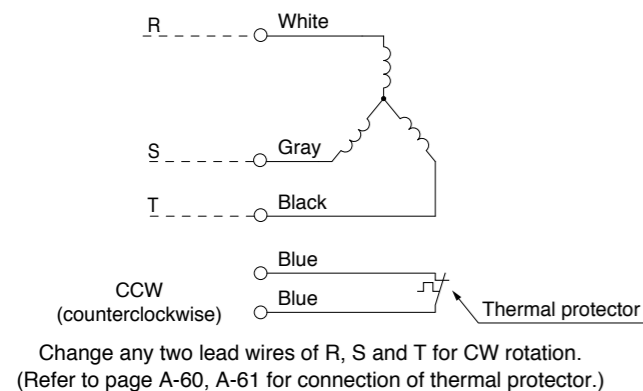

Speed-torque characteristics

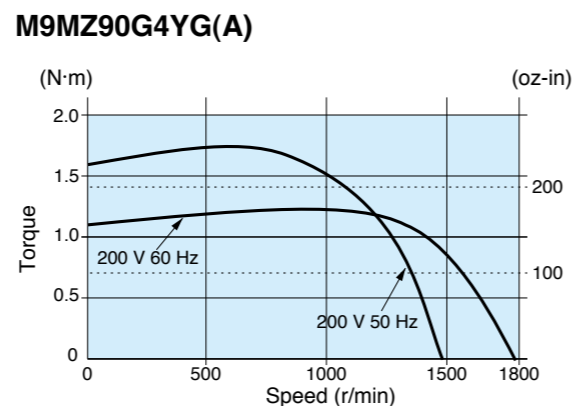

* Please read your User's manual carefully so that you will understand the operation and safety precautions before attempting to operate the system.

[Features B-126](#)
[System configuration B-127](#)
[Coding system B-127](#)
[Model list B-128](#)

Motor (dimensions)

Scale: 1/4, Unit: mm (inch)

M9MZ90G4YG(A) 4P 90 W 200 V / 220 V / 230 V (with fan)

Mass **3.2 kg** (7.05 lb)
 Helical gear
 Module **0.6**
 Number of teeth **9**

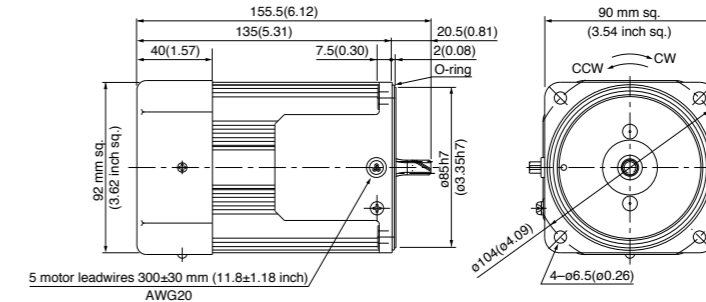

Gear head (dimensions)

Scale: 1/4, Unit: mm (inch)

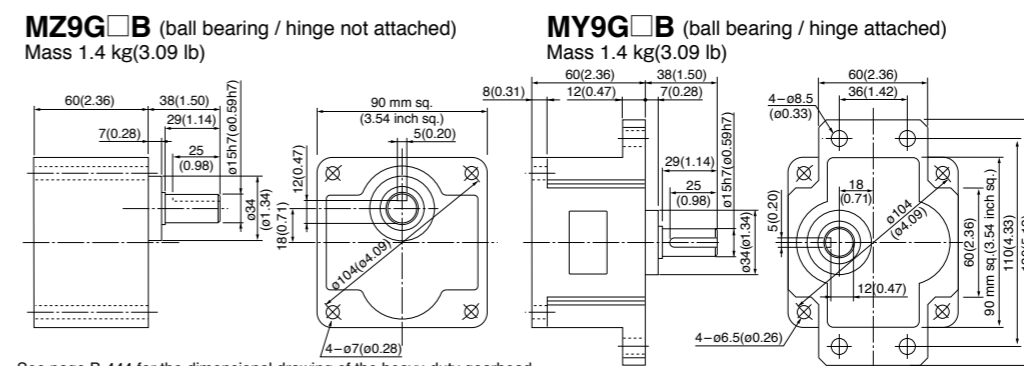

See page B-444 for the dimensional drawing of the heavy-duty gearhead.
See page B-446 for the dimensional drawing of the right-angle shaft type gearhead.

Note) MZ / MY is available for a gear head of either type.
(Note) Because the dimensions may be subject to change, also check the determinate dimensions if the gear head is to be used for design.

[Gear head combination B-162](#)
[Round shaft motor B-164](#)
[Decimal gear head B-448](#)
[Gear head -inch \(U.S.A.\) B-449](#)
[Controls C-4](#)
[Option D-2](#)

Key and keyway (dimensions) [attachment]

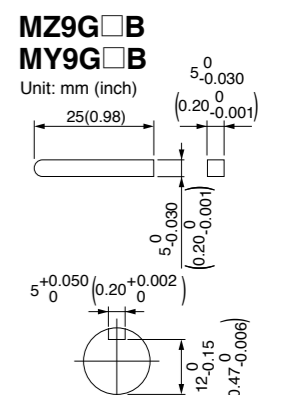

Induction motor
 Reversible motor
 3-phase motor
 Electromagnetic brake motor
 Variable speed induction motor
 Variable speed electromagnetic brake single-phase motor
 Variable speed unit motor
 C&B motor
 2-pole round shaft motor
 Gear head
 Gear head -inch (U.S.A.)

3-phase motor (sealed connector)

80 mm (3.15 inch) sq. 25 W

Specifications

Size	Motor model No.	Number of pole (P)	Output (W)	Voltage (V)	Frequency (Hz)	Rating (min)	Rating				Starting current (A)	Starting torque N-m (oz-in)
							Input (W)	Current (A)	Speed (r/min)	Torque N-m (oz-in)		
80 mm sq.	M8MX25GK4Y	4	25	200	50	Cont.	50	0.25	1350	0.18 (25.5)	0.62	0.54 (76.5)
					60	Cont.	47	0.22	1625	0.15 (21.2)	0.58	0.40 (56.6)
				220	50	Cont.	54	0.27	1375	0.18 (25.5)	0.67	0.66 (93.5)
					60	Cont.	49	0.23	1650	0.15 (21.2)	0.64	0.50 (70.8)

The specifications and wire connections of the round shaft motor are the same as those of the pinion shaft type. For the dimensional outline drawing, refer to page B-165. For the combination of motor and gearhead, refer to pages B-128 and B-129 of applicable gearheads in the model list.

Permissible torque at output shaft of gear head

The speed shown below is a calculated value based on the synchronous rotational speed. Depending on the load, the speed is less than the indicated value by 2% to 20%.

Unit of permissible torque: upper (N·m) / lower (lb·in)

Reduction ratio	Unit of permissible torque: upper (N·m) / lower (lb·in)																							
	3	3.6	5	6	7.5	9	10	12.5	15	18	20	25	30	36	50	60	75	90	100	120	150	180		
Speed (r/min)	50 Hz	500	416.7	300	250	200	166.7	150	120	100	83.3	75	60	50	41.7	30	25	20	16.7	15	12.5	10	8.3	
	60 Hz	600	500	360	300	240	200	180	144	120	100	90	72	60	50	36	30	24	20	18	15	12	10	
Applicable gear head	MX8G3B to MX8G180B (ball bearing)	50 Hz	0.39 (3.45)	0.47 (4.16)	0.66 (5.84)	0.78 (6.90)	0.98 (8.67)	1.18 (10.4)	1.27 (11.2)	1.57 (13.9)	1.96 (17.3)	2.35 (20.8)	2.55 (22.6)	3.14 (27.8)	3.82 (33.8)	4.61 (40.8)	6.37 (56.4)	7.64 (67.6)						7.84 (69.4)
		60 Hz	0.32 (2.83)	0.39 (3.45)	0.55 (4.87)	0.66 (5.84)	0.81 (7.17)	0.98 (8.67)	1.08 (9.56)	1.27 (11.2)	1.57 (13.9)	1.96 (17.3)	2.06 (18.2)	2.65 (23.5)	3.14 (27.8)	3.82 (33.8)	5.29 (46.8)	6.37 (56.4)						7.84 (69.4)
Rotational direction		Same as motor rotational direction											Reverse to motor rotational direction											

Permissible torque at output shaft of gear head using decimal gear head

For external dimensions of the decimal gear head, refer to page B-448.

Applicable gear head		Reduction ratio	Reduction ratio														
Bearing	Decimal gear head		Speed (r/min)	50 Hz		200	250	300	360	500	600	750	900	1000	1200	1500	1800
		MX8G□B (ball bearing)		MX8G10XB	Permissible torque	N·m (lb·in)		7.84 (69.4)	7.84 (69.4)	7.84 (69.4)	7.84 (69.4)	7.84 (69.4)	7.84 (69.4)	7.84 (69.4)	7.84 (69.4)	7.84 (69.4)	7.84 (69.4)
Rotational direction			Same as motor rotational direction			Reverse to motor rotational direction											

Motor (dimensions)

M8MX25GK4Y 4P 25 W 200 V / 220 V

Scale: 1/3, Unit: mm (inch)

Mass 1.8 kg 3.97 lb
Helical gear
Module 0.5
Number of teeth 9

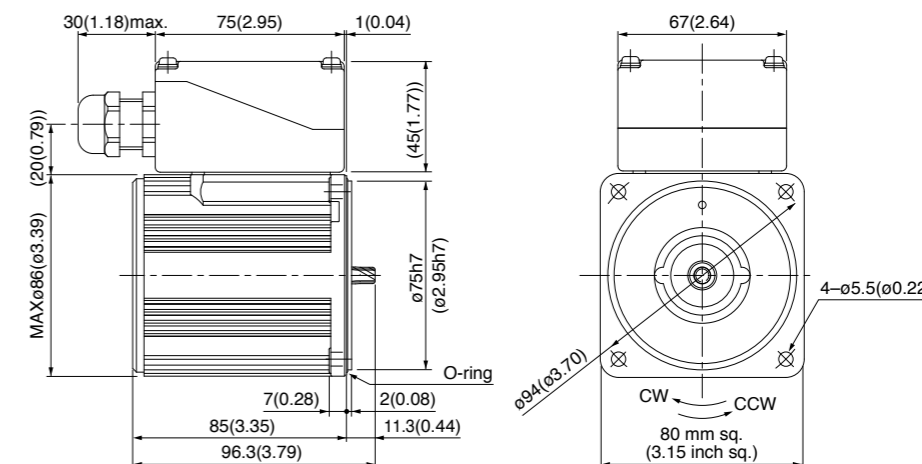

* Diameter of applicable cable to be ø8(ø0.31) to ø12(ø0.47).

Connection diagram

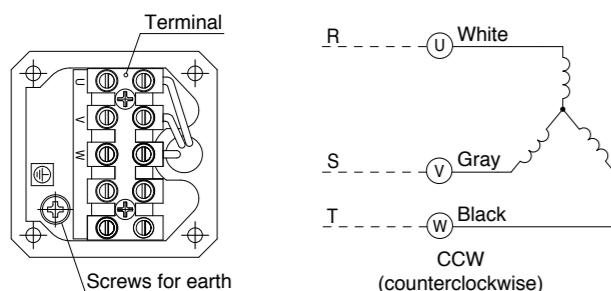

Change any two lead wires of U, V and W for CW rotation.

Speed-torque characteristics

M8MX25GK4Y

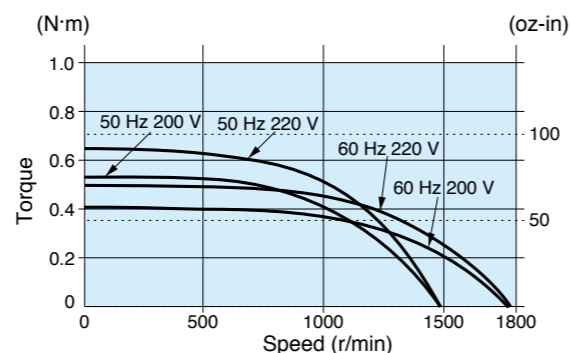

Gear head (dimensions)

Scale: 1/3, Unit: mm (inch)

MX8G□B (ball bearing) Mass 0.6 kg (1.32 lb) MX8G□M (metal bearing) Mass 0.6 kg (1.32 lb)

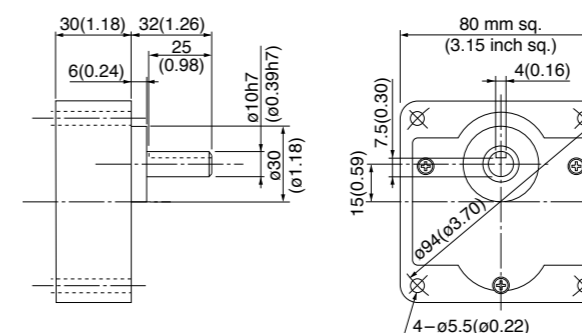

Key and keyway (dimensions) [attachment]

MX8G□B(M)

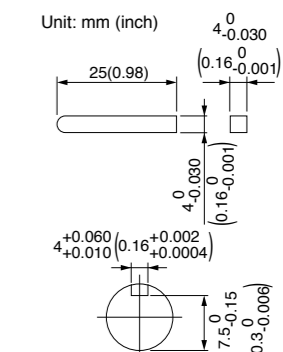

Please read your User's manual carefully so that you will understand the operation and safety precautions before attempting to operate the system.

Features B-126 System configuration B-127 Coding system B-127 Model list B-128

(Note) Because the dimensions may be subject to change, also check the determinate dimensions if the gear head is to be used for design.

Gear head combination B-163 Round shaft motor B-165 Decimal gear head B-448 Gear head -inch (U.S.A.) B-449 Controls C-4 Option D-2

3-phase motor (sealed connector)

80 mm (3.15 inch) sq. 25 W

Specifications

Size	Motor model No.	Number of pole (P)	Output (W)	Voltage (V)	Frequency (Hz)	Rating (min)	Rating				Starting current (A)	Starting torque N-m (oz-in)
							Input (W)	Current (A)	Speed (r/min)	Torque N-m (oz-in)		
80 mm sq.	M8MX25GK4YG M8MX25GK4YGA	4	25	200	50	Cont.	50	0.25	1350	0.18 (25.5)	0.62	0.54 (76.5)
					60		47	0.22	1625	0.15 (21.2)	0.58	0.40 (56.6)
				220	60	49	0.23	1650	0.14 (19.8)	0.64	0.50 (70.8)	
					60	50	0.24	1675	0.14 (19.8)	0.65	0.54 (76.5)	
	230	60	49	0.12	1325	0.18 (25.5)	0.29	0.50 (70.8)				
		50	52	0.12	1325	0.18 (25.5)	0.32	0.56 (79.3)				
M8MX25GK4CG* M8MX25GK4CGA	4	25	380	50	Cont.	49	0.12	1325	0.18 (25.5)	0.29	0.50 (70.8)	
			400	50		52	0.12	1325	0.18 (25.5)	0.32	0.56 (79.3)	

* Do not use an inverter to drive 380 V/400 V motor. (The surge voltage due to the switching of the inverter causes, the motor to withstand pressure failure.)
 • The specifications and wire connections of the round shaft motor are the same as those of the pinion shaft type. For the dimensional outline drawing, refer to page B-165.
 • The models with a motor model number to which "A" is suffixed are not sold or available in Japan.
 • For the combination of motor and gearhead, refer to pages B-128 and B-129 of applicable gearheads in the model list.

Permissible torque at output shaft of gear head

* The speed shown below is a calculated value based on the synchronous rotational speed. Depending on the load, the speed is less than the indicated value by 2% to 20%.

Unit of permissible torque: upper (N·m) / lower (lb-in)

Reduction ratio	Speed (r/min)																										
	50 Hz	60 Hz	3	3.6	5	6	7.5	9	10	12.5	15	18	20	25	30	36	50	60	75	90	100	120	150	180			
MX8G3B to MX8G180B (ball bearing)	0.39 (3.45)	0.47 (4.16)	0.66 (5.84)	0.78 (6.90)	0.98 (8.67)	1.18 (10.4)	1.27 (11.2)	1.57 (13.9)	1.96 (17.3)	2.35 (20.8)	2.55 (22.6)	3.14 (27.8)	3.82 (33.8)	4.61 (40.8)	6.37 (56.4)	7.64 (67.6)											7.84 (69.4)
MX8G3M to MX8G180M (metal bearing)	0.32 (2.83)	0.39 (3.45)	0.55 (4.87)	0.66 (5.84)	0.81 (7.17)	0.98 (8.67)	1.08 (9.56)	1.27 (11.2)	1.57 (13.9)	1.96 (17.3)	2.06 (18.2)	2.65 (23.5)	3.14 (27.8)	3.82 (33.8)	5.29 (46.8)	6.37 (56.4)											7.84 (69.4)
Rotational direction	Same as motor rotational direction												Reverse to motor rotational direction														

Permissible torque at output shaft of gear head using decimal gear head

* For external dimensions of the decimal gear head, refer to page B-448.

Applicable gear head		Reduction ratio	Speed (r/min)													
Bearing	Decimal gear head		50 Hz	60 Hz	200	250	300	360	500	600	750	900	1000	1200	1500	1800
MX8G□B (ball bearing)	MX8G10XB	Permissible torque	N·m (69.4)	N·m (69.4)	7.84 (69.4)	7.84 (69.4)	7.84 (69.4)	7.84 (69.4)	7.84 (69.4)	7.84 (69.4)	7.84 (69.4)	7.84 (69.4)	7.84 (69.4)	7.84 (69.4)	7.84 (69.4)	7.84 (69.4)
MX8G□M (metal bearing)		Rotational direction	Same as motor rotational direction		Reverse to motor rotational direction											

Connection diagram

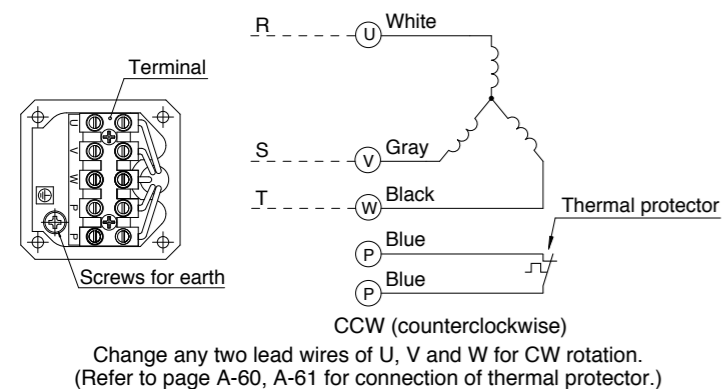

Speed-torque characteristics

M8MX25GK4YG(A) / M8MX25GK4CG(A)

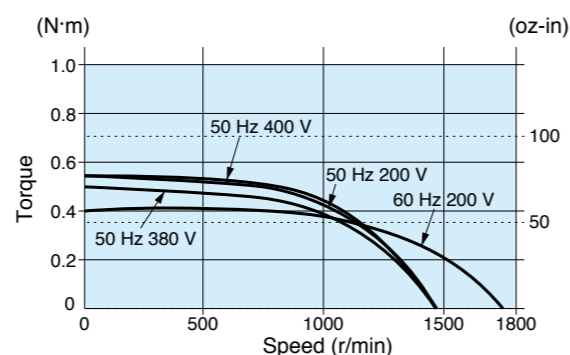

* Please read your User's manual carefully so that you will understand the operation and safety precautions before attempting to operate the system.

[Features B-126](#)
[System configuration B-127](#)
[Coding system B-127](#)
[Model list B-128](#)

Motor (dimensions)

Scale: 1/3, Unit: mm (inch)

M8MX25GK4YG(A) 4P 25 W 200 V / 220 V / 230 V
M8MX25GK4CG(A) 4P 25 W 380 V / 400 V

Mass **1.8 kg** / 3.97 lb
 Helical gear
 Module **0.5**
 Number of teeth **9**

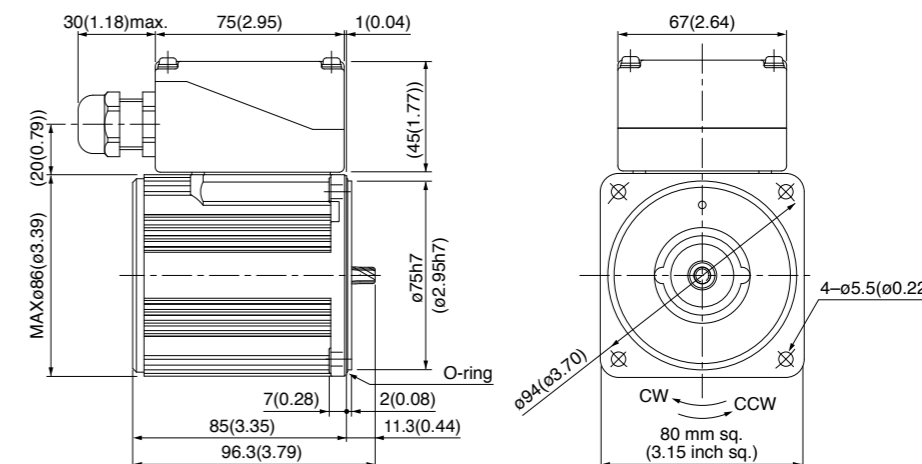

* Diameter of applicable cable to be ø8(ø0.31) to ø12(ø0.47).

Gear head (dimensions)

Scale: 1/3, Unit: mm (inch)

MX8G□B (ball bearing) Mass 0.6 kg(1.32 lb)
 MX8G□M (metal bearing) Mass 0.6 kg(1.32 lb)

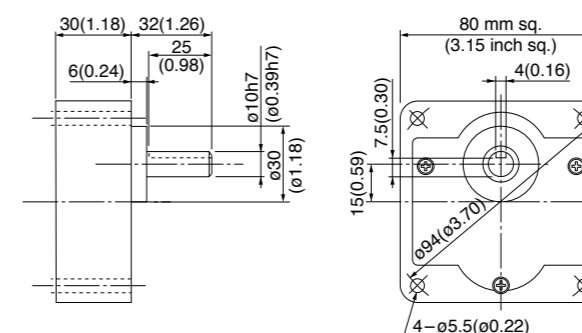

Key and keyway (dimensions) [attachment]

MX8G□B(M)

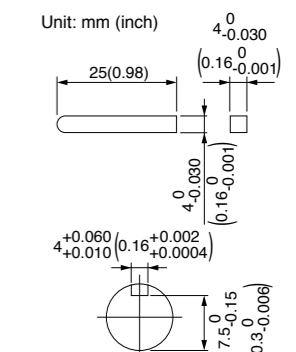

(Note) Because the dimensions may be subject to change, also check the determinate dimensions if the gear head is to be used for design.

[Gear head combination B-163](#)
[Round shaft motor B-165](#)
[Decimal gear head B-448](#)
[Gear head -inch \(U.S.A.\) B-449](#)
[Controls C-4](#)
[Option D-2](#)

3-phase motor (sealed connector)

90 mm (3.54 inch) sq. 40 W

Specifications

Size	Motor model No.	Number of pole (P)	Output (W)	Voltage (V)	Frequency (Hz)	Rating (min)	Rating				Starting current (A)	Starting torque N-m (oz-in)
							Input (W)	Current (A)	Speed (r/min)	Torque N-m (oz-in)		
90 mm sq.	M9MX40GK4Y	4	40	200	50	Cont.	69	0.31	1350	0.28 (39.7)	0.90	0.72 (102)
					60	Cont.	68	0.29	1625	0.24 (34.0)	0.82	0.51 (72.2)
				220	50	Cont.	70	0.32	1375	0.27 (38.2)	1.0	0.88 (125)
					60	Cont.	66	0.28	1675	0.23 (32.6)	0.91	0.63 (89.2)

* The specifications and wire connections of the round shaft motor are the same as those of the pinion shaft type. For the dimensional outline drawing, refer to page B-165.
 * For the combination of motor and gearhead, refer to pages B-128 and B-129 of applicable gearheads in the model list.

Permissible torque at output shaft of gear head

* The speed shown below is a calculated value based on the synchronous rotational speed. Depending on the load, the speed is less than the indicated value by 2% to 20%.

Unit of permissible torque: upper (N·m) / lower (lb·in)

Reduction ratio	Speed (r/min)																								
	50 Hz	60 Hz	500	416.7	300	250	200	166.7	150	120	100	83.3	75	60	50	41.7	30	25	20	16.7	15	12.5	10	8.3	
Applicable gear head	MX9G3B to MX9G180B (ball bearing)	50 Hz	0.66 (5.84)	0.78 (6.90)	1.08 (9.56)	1.27 (11.2)	1.57 (13.9)	1.86 (16.5)	2.25 (19.9)	2.74 (24.3)	3.23 (28.6)	3.92 (34.7)	4.41 (39.0)	5.29 (46.8)	6.37 (56.4)	7.94 (70.3)	9.80 (86.7)								9.80 (86.7)
		60 Hz	0.55 (4.87)	0.66 (5.84)	0.90 (7.97)	1.08 (9.56)	1.27 (11.2)	1.57 (13.9)	1.76 (15.6)	2.25 (19.9)	2.74 (24.3)	3.23 (28.6)	3.53 (31.2)	4.41 (39.0)	5.29 (46.8)	6.37 (56.4)	8.82 (78.1)								9.80 (86.7)
Rotational direction		Same as motor rotational direction												Reverse to motor rotational direction											

Permissible torque at output shaft of gear head using decimal gear head

* For external dimensions of the decimal gear head, refer to page B-448.

Applicable gear head		Reduction ratio	Speed (r/min)													
Bearing	Decimal gear head		50 Hz	60 Hz	200	250	300	360	500	600	750	900	1000	1200	1500	1800
MX9G□B (ball bearing) MX9G□M (metal bearing)	MX9G10XB	Permissible torque	N·m (lb-in)	9.80 (86.7)	9.80 (86.7)	9.80 (86.7)	9.80 (86.7)	9.80 (86.7)	9.80 (86.7)	9.80 (86.7)	9.80 (86.7)	9.80 (86.7)	9.80 (86.7)	9.80 (86.7)	9.80 (86.7)	9.80 (86.7)
		Rotational direction	Same as motor rotational direction	Reverse to motor rotational direction												

Refer to page B-446 for the allowable shaft torque of the right-angle shaft type gearhead.

Motor (dimensions)

M9MX40GK4Y 4P 40 W 200 V / 220 V

Scale: 1/3, Unit: mm (inch)

Mass 2.8 kg 6.17 lb
 Helical gear
 Module 0.55
 Number of teeth 9

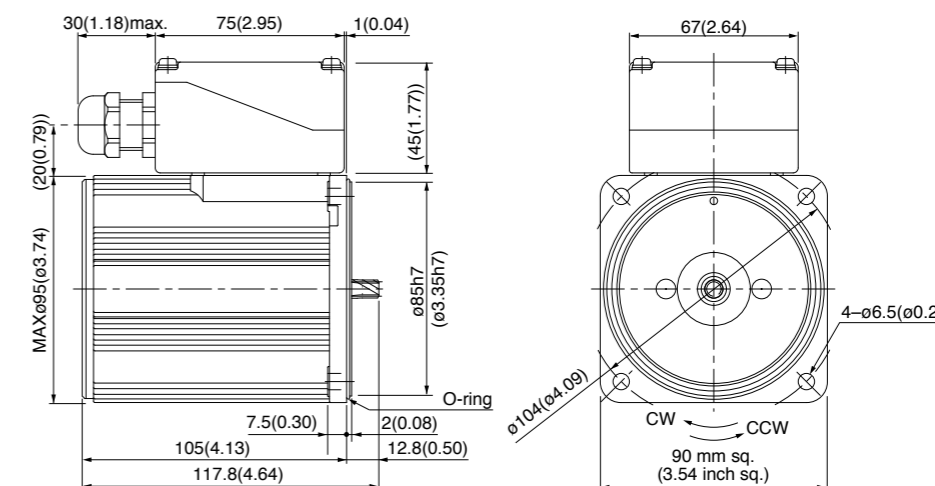

* Diameter of applicable cable to be φ8 (φ0.31) to φ12 (φ0.47).

Connection diagram

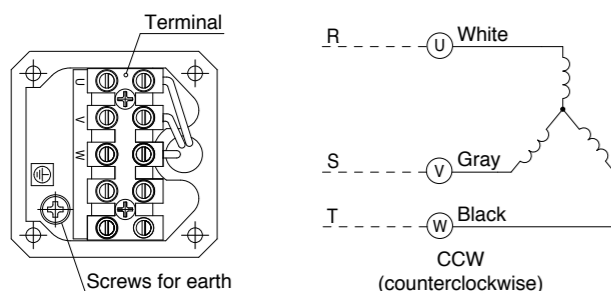

Change any two lead wires of U, V and W for CW rotation.

Speed-torque characteristics

M9MX40GK4Y

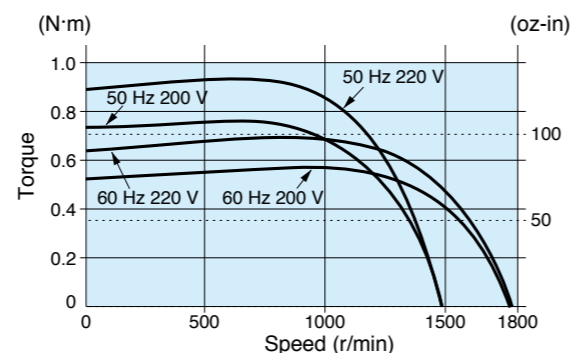

Gear head (dimensions)

Scale: 1/3, Unit: mm (inch)

MX9G□B (ball bearing) Mass 0.8 kg (1.76 lb) MX9G□M (metal bearing) Mass 0.8 kg (1.76 lb)

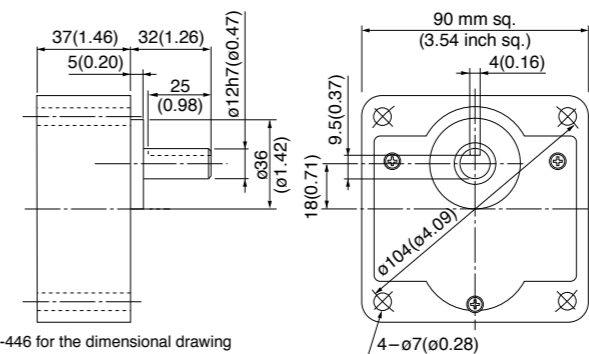

See page B-446 for the dimensional drawing of the right-angle shaft type gearhead.

(Note) Because the dimensions may be subject to change, also check the determinate dimensions if the gear head is to be used for design.

Key and keyway (dimensions) [attachment]

MX9G□B(M)

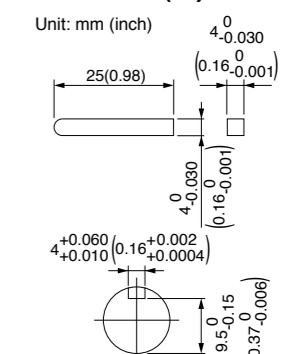

* Please read your User's manual carefully so that you will understand the operation and safety precautions before attempting to operate the system.

Features B-126 System configuration B-127 Coding system B-127 Model list B-128

Gear head combination B-163 Round shaft motor B-165 Decimal gear head B-448 Gear head -inch (U.S.A.) B-449 Controls C-4 Option D-2

3-phase motor (sealed connector)

90 mm (3.54 inch) sq. 40 W

Specifications

Size	Motor model No.	Number of pole (P)	Output (W)	Voltage (V)	Frequency (Hz)	Rating (min)	Rating				Starting current (A)	Starting torque N·m (oz-in)
							Input (W)	Current (A)	Speed (r/min)	Torque N·m (oz-in)		
90 mm sq.	M9MX40GK4YG M9MX40GK4YGA	4	40	200	50	Cont.	69	0.31	1350	0.28 (39.7)	0.90	0.72 (102)
					60		68	0.29	1625	0.24 (34.0)	0.82	0.51 (72.2)
				230	60	66	0.28	1675	0.23 (32.6)	0.91	0.63 (89.2)	
					60	66	0.29	1675	0.23 (32.6)	0.96	0.69 (97.7)	
	M9MX40GK4CG* M9MX40GK4CGA	4	40	380	50	Cont.	68	0.15	1325	0.29 (41.1)	0.44	0.64 (90.6)
				400	50		66	0.15	1350	0.28 (39.7)	0.47	0.74 (105)

* Do not use an inverter to drive 380 V/400 V motor. (The surge voltage due to the switching of the inverter causes, the motor to withstand pressure failure.)
 • The specifications and wire connections of the round shaft motor are the same as those of the pinion shaft type. For the dimensional outline drawing, refer to page B-165.
 • The models with a motor model number to which "A" is suffixed are not sold or available in Japan.
 • For the combination of motor and gearhead, refer to pages B-128 and B-129 of applicable gearheads in the model list.

Permissible torque at output shaft of gear head

* The speed shown below is a calculated value based on the synchronous rotational speed. Depending on the load, the speed is less than the indicated value by 2% to 20%.

Unit of permissible torque: upper (N·m) / lower (lb-in)

Reduction ratio	Speed (r/min)																								
	50 Hz	60 Hz	3	3.6	5	6	7.5	9	10	12.5	15	18	20	25	30	36	50	60	75	90	100	120	150	180	
MX9G3B to MX9G180B (ball bearing)	0.66 (5.84)	0.78 (6.90)	1.08 (9.56)	1.27 (11.2)	1.57 (13.9)	1.86 (16.5)	2.25 (19.9)	2.74 (24.3)	3.23 (28.6)	3.92 (34.7)	4.41 (39.0)	5.29 (46.8)	6.37 (56.4)	7.94 (70.3)	9.80 (86.7)										
MX9G3M to MX9G180M (metal bearing)	0.55 (4.87)	0.66 (5.84)	0.90 (7.97)	1.08 (9.56)	1.27 (11.2)	1.57 (13.9)	1.76 (15.6)	2.25 (19.9)	2.74 (24.3)	3.23 (28.6)	3.53 (31.2)	4.41 (39.0)	5.29 (46.8)	6.37 (56.4)	8.82 (78.1)										
Rotational direction	Same as motor rotational direction												Reverse to motor rotational direction												

Permissible torque at output shaft of gear head using decimal gear head

* For external dimensions of the decimal gear head, refer to page B-448.

Applicable gear head		Reduction ratio	Speed (r/min)													
Bearing	Decimal gear head		50 Hz	60 Hz	200	250	300	360	500	600	750	900	1000	1200	1500	1800
MX9G□B (ball bearing)	MX9G10XB	Permissible torque	N·m (86.7)	N·m (86.7)	N·m (86.7)	N·m (86.7)	N·m (86.7)	N·m (86.7)	N·m (86.7)	N·m (86.7)	N·m (86.7)	N·m (86.7)	N·m (86.7)	N·m (86.7)	N·m (86.7)	N·m (86.7)
MX9G□M (metal bearing)		Rotational direction	Same as motor rotational direction													

Refer to page B-446 for the allowable shaft torque of the right-angle shaft type gearhead.

Connection diagram

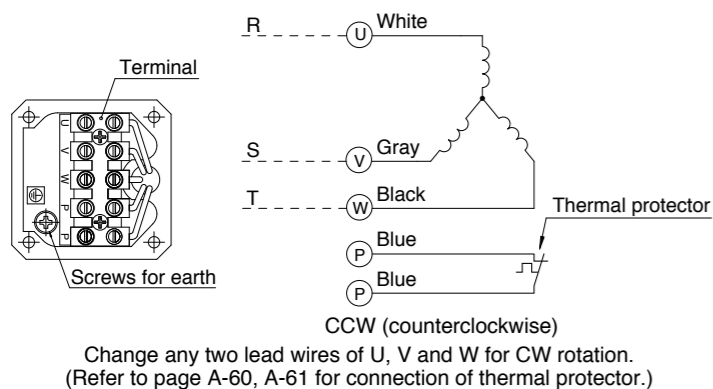

Speed-torque characteristics

M9MX40GK4YG(A) / M9MX40GK4CG(A)

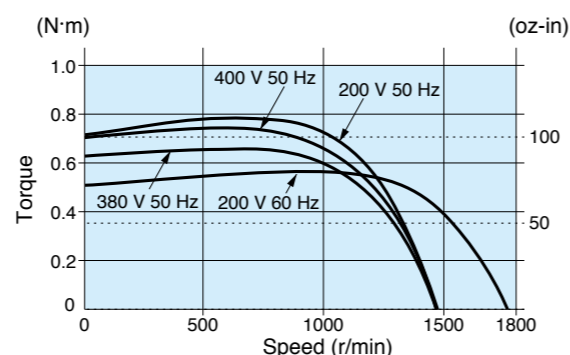

* Please read your User's manual carefully so that you will understand the operation and safety precautions before attempting to operate the system.

[Features B-126](#)
[System configuration B-127](#)
[Coding system B-127](#)
[Model list B-128](#)

Motor (dimensions)

Scale: 1/3, Unit: mm (inch)

M9MX40GK4YG(A) 4P 40 W 200 V / 220 V / 230 V
M9MX40GK4CG(A) 4P 40 W 380 V / 400 V

Mass **2.8 kg** / 6.17 lb
 Helical gear
 Module **0.55**
 Number of teeth **9**

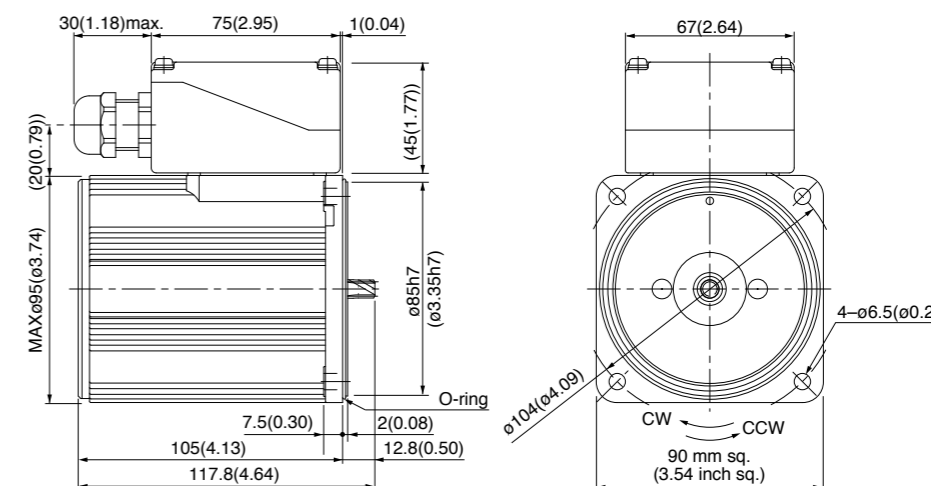

* Diameter of applicable cable to be $\phi 8(\phi 0.31)$ to $\phi 12(\phi 0.47)$.

Gear head (dimensions)

Scale: 1/3, Unit: mm (inch)

MX9G□B (ball bearing) Mass 0.8 kg (1.76 lb)
 MX9G□M (metal bearing) Mass 0.8 kg (1.76 lb)

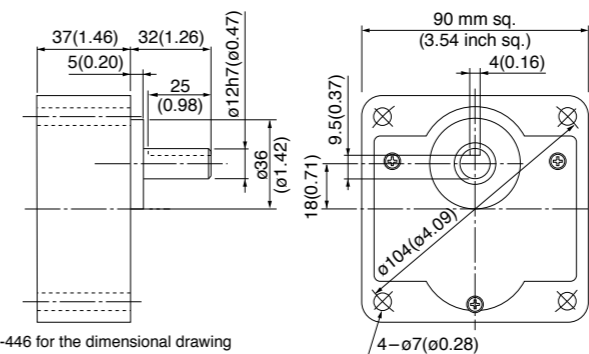

See page B-446 for the dimensional drawing of the right-angle shaft type gearhead.

(Note) Because the dimensions may be subject to change, also check the determinate dimensions if the gear head is to be used for design.

[Gear head combination B-163](#)
[Round shaft motor B-165](#)
[Decimal gear head B-448](#)
[Gear head -inch \(U.S.A.\) B-449](#)
[Controls C-4](#)
[Option D-2](#)

Key and keyway (dimensions) [attachment]

MX9G□B(M)

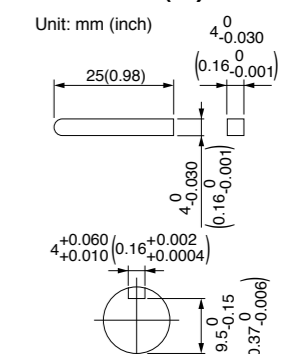

3-phase motor (sealed connector)

90 mm (3.54 inch) sq. 60 W

Specifications

Size	Motor model No.	Number of pole (P)	Output (W)	Voltage (V)	Frequency (Hz)	Rating (min)	Rating				Starting current (A)	Starting torque N-m (oz-in)
							Input (W)	Current (A)	Speed (r/min)	Torque N-m (oz-in)		
90 mm sq.	M9MZ60GK4YG M9MZ60GK4YGA	4	60	200	50	Cont.	101	0.45	1350	0.42 (59.5)	1.3	1.0 (142)
					60		96	0.41	1625	0.35 (49.6)	1.2	0.69 (97.7)
				230	60	98	0.40	1650	0.35 (49.6)	1.3	0.87 (123)	
					60	98	0.41	1675	0.34 (48.1)	1.4	1.0 (142)	
	M9MZ60GK4CG* M9MZ60GK4CGA	4	60	380	50	Cont.	98	0.22	1325	0.43 (60.9)	0.62	0.88 (125)
				400	50		98	0.22	1325	0.43 (60.9)	0.65	1.0 (142)

* Do not use an inverter to drive 380 V/400 V motor. (The surge voltage due to the switching of the inverter causes, the motor to withstand pressure failure.)
 • The specifications and wire connections of the round shaft motor are the same as those of the pinion shaft type. For the dimensional outline drawing, refer to page B-165.
 • The models with a motor model number to which "A" is suffixed are not sold or available in Japan.
 • For the combination of motor and gearhead, refer to pages B-128 and B-129 of applicable gearheads in the model list.

Permissible torque at output shaft of gear head

* The speed shown below is a calculated value based on the synchronous rotational speed. Depending on the load, the speed is less than the indicated value by 2 % to 20 %.

Unit of permissible torque: upper (N·m) / lower (lb-in)

Reduction ratio	3	3.6	5	6	7.5	9	10	12.5	15	18	20	25	30	36	50	60	75	90	100	120	150	180	200	
Speed (r/min)	50 Hz	500	416.7	300	250	200	166.7	150	120	100	83.3	75	60	50	41.7	30	25	20	16.7	15	12.5	10	8.3	7.5
	60 Hz	600	500	360	300	240	200	180	144	120	100	90	72	60	50	36	30	24	20	18	15	12	10	9
Applicable gear head	MZ9G3B to MZ9G200B (ball bearing / hinge not attached)	50 Hz	0.98 (8.7)	1.18 (10.4)	1.57 (13.9)	1.96 (17.3)	2.35 (20.8)	2.94 (26.0)	3.14 (27.8)	3.92 (34.7)	4.70 (41.6)	5.59 (49.5)	6.27 (55.5)	7.55 (66.8)	9.11 (80.6)	11.0 (97.4)	15.2 (135)	17.8 (158)						19.6 (173)
	MY9G3B to MY9G200B (ball bearing / hinge attached)	60 Hz	0.78 (6.9)	0.98 (8.7)	1.37 (12.1)	1.57 (13.9)	1.96 (17.3)	2.65 (23.5)	3.33 (29.5)	3.92 (34.7)	4.70 (41.6)	5.29 (46.8)	6.47 (57.3)	7.55 (66.8)	9.11 (80.6)	12.6 (112)	15.2 (135)							
Rotational direction		Same as motor rotational direction						Reverse to motor rotational direction						Same as motor rotational direction										

Permissible torque at output shaft of gear head using decimal gear head

* For external dimensions of the decimal gear head, refer to page B-448.

Applicable gear head		Reduction ratio	250	300	360	500	600	750	900	1000	1200	1500	1800	2000	
Bearing	Decimal gear head	Speed (r/min)	50 Hz	6	5	4.2	3	2.5	2	1.7	1.5	1.3	1	0.8	0.75
		60 Hz	7.2	6	5	3.6	3	2.4	2	1.8	1.5	1.2	1	0.9	
MZ9G□B (ball bearing / hinge not attached) MY9G□B (ball bearing / hinge attached)	MZ9G10XB	Permissible torque	N·m	19.6 (173)	19.6 (173)	19.6 (173)	19.6 (173)	19.6 (173)	19.6 (173)	19.6 (173)	19.6 (173)	19.6 (173)	19.6 (173)	19.6 (173)	19.6 (200)
		Rotational direction		Reverse to motor rotational direction						Same as motor rotational direction					

Refer to pages B-444 and B-445 for the allowable shaft torque of the heavy-duty gearhead.
 Refer to page B-446 for the allowable shaft torque of the right-angle shaft type gearhead.

Connection diagram

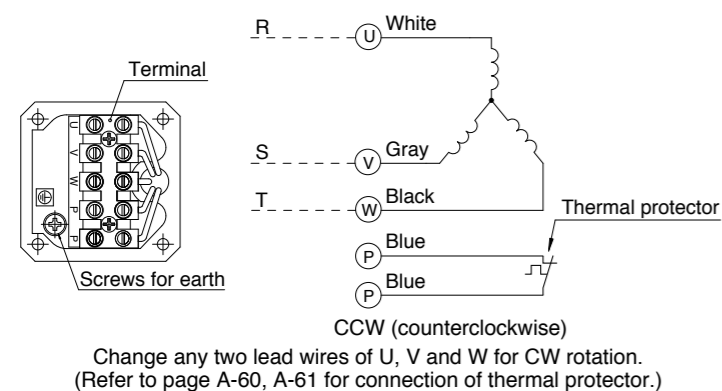

Speed-torque characteristics

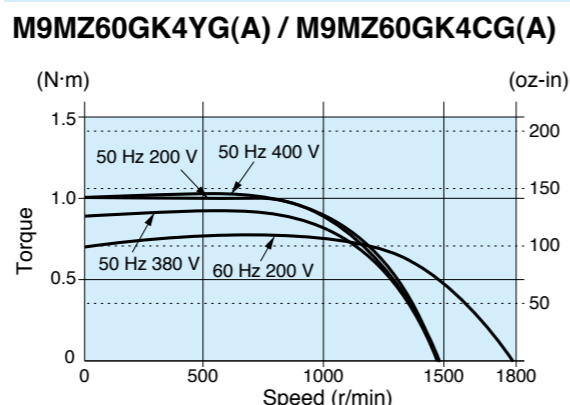

* Please read your User's manual carefully so that you will understand the operation and safety precautions before attempting to operate the system.

[Features B-126](#)
[System configuration B-127](#)
[Coding system B-127](#)
[Model list B-128](#)

Motor (dimensions)

Scale: 1/4, Unit: mm (inch)

M9MZ60GK4YG(A) 4P 60 W 200 V / 220 V / 230 V (with fan)
M9MZ60GK4CG(A) 4P 60 W 380 V / 400 V (with fan)

Mass **3.0 kg** / **6.61 lb**
 Helical gear
 Module **0.6**
 Number of teeth **9**

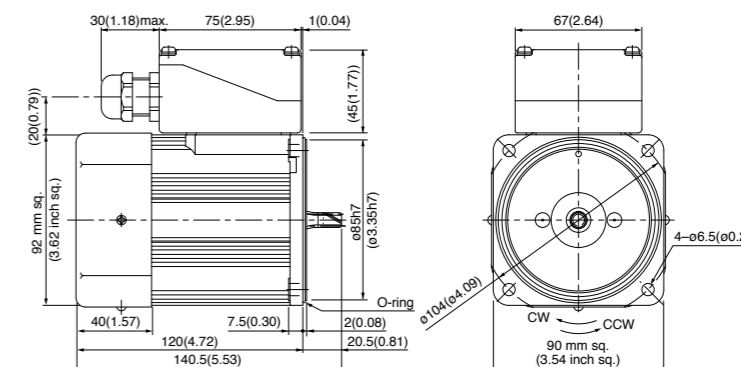

* Diameter of applicable cable to be ø8(ø0.31) to ø12(ø0.47).

Gear head (dimensions)

Scale: 1/4, Unit: mm (inch)

MZ9G□B (ball bearing / hinge not attached)
 Mass 1.4 kg (3.09 lb)
MY9G□B (ball bearing / hinge attached)
 Mass 1.4 kg (3.09 lb)

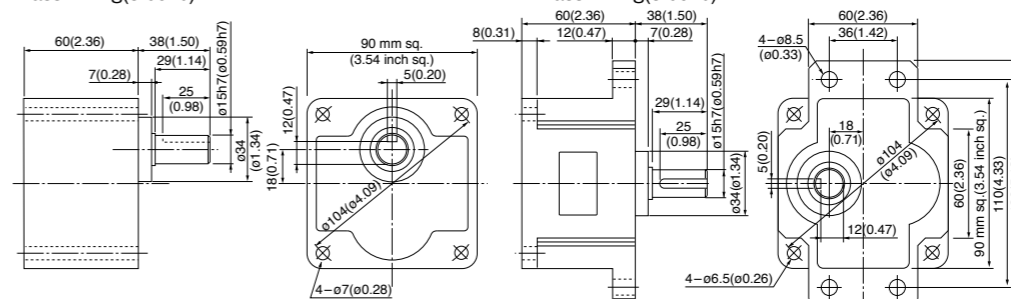

See page B-444 for the dimensional drawing of the heavy-duty gearhead.
 See page B-446 for the dimensional drawing of the right-angle shaft type gearhead.

Note) MZ / MY is available for a gear head of either type.
 (Note) Because the dimensions may be subject to change, also check the determinate dimensions if the gear head is to be used for design.

[Gear head combination B-163](#)
[Round shaft motor B-165](#)
[Decimal gear head B-448](#)
[Gear head -inch \(U.S.A.\) B-449](#)
[Controls C-4](#)
[Option D-2](#)

Key and keyway (dimensions) [attachment]

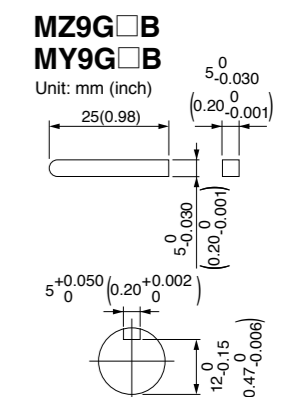

3-phase motor (sealed connector)

90 mm (3.54 inch) sq. 90 W

Specifications

Size	Motor model No.	Number of pole (P)	Output (W)	Voltage (V)	Frequency (Hz)	Rating (min)	Rating				Starting current (A)	Starting torque N-m (oz-in)
							Input (W)	Current (A)	Speed (r/min)	Torque N-m (oz-in)		
90 mm sq.	M9MZ90GK4Y	4	90	200	50	Cont.	141	0.62	1350	0.63 (89.2)	2.0	1.6 (227)
					60	Cont.	137	0.56	1625	0.53 (75.1)	1.8	1.1 (156)
				220	50	Cont.	143	0.65	1400	0.62 (87.8)	2.2	2.0 (283)
					60	Cont.	137	0.56	1650	0.52 (73.6)	2.0	1.4 (198)

* The specifications and wire connections of the round shaft motor are the same as those of the pinion shaft type. For the dimensional outline drawing, refer to page B-165.
 * For the combination of motor and gearhead, refer to pages B-128 and B-129 of applicable gearheads in the model list.

Permissible torque at output shaft of gear head

* The speed shown below is a calculated value based on the synchronous rotational speed. Depending on the load, the speed is less than the indicated value by 2% to 20%.

Unit of permissible torque: upper (N·m) / lower (lb·in)

Reduction ratio	Speed (r/min)																										
	50 Hz	60 Hz	500	416.7	300	250	200	166.7	150	120	100	83.3	75	60	50	41.7	30	25	20	16.7	15	12.5	10	8.3	7.5		
Applicable gear head	MZ9G3B to MZ9G200B (ball bearing / hinge not attached)	50 Hz	1.37 (12.1)	1.67 (14.8)	2.25 (19.9)	2.74 (24.3)	3.43 (30.4)	4.12 (36.5)	4.51 (39.9)	5.68 (50.3)	6.76 (59.8)	8.04 (71.2)	9.02 (79.8)	10.9 (96.5)	13.0 (115)	15.7 (139)	19.6 (173)										
		60 Hz	1.18 (10.4)	1.37 (12.1)	1.86 (16.5)	2.25 (19.9)	2.84 (25.1)	3.43 (30.4)	3.72 (32.9)	4.70 (41.6)	5.68 (50.3)	6.76 (59.8)	7.55 (66.8)	9.21 (81.5)	10.9 (96.5)	13.0 (115)	18.3 (162)	19.6 (173)									
Rotational direction	Same as motor rotational direction										Reverse to motor rotational direction																

Permissible torque at output shaft of gear head using decimal gear head

* For external dimensions of the decimal gear head, refer to page B-448.

Applicable gear head		Reduction ratio	Speed (r/min)																							
Bearing	Decimal gear head		50 Hz	60 Hz	250	300	360	500	600	750	900	1000	1200	1500	1800	2000										
MZ9G□B (ball bearing / hinge not attached)	MZ9G10XB	50 Hz	6	5	4.2	3	2.5	2	1.7	1.5	1.3	1	0.8	0.75												
		60 Hz	7.2	6	5	3.6	3	2.4	2	1.8	1.5	1.2	1	0.9												
MY9G□B (ball bearing / hinge attached)	MZ9G10XB	Permissible torque	N·m (lb-in)	19.6 (173)	19.6 (173)	19.6 (173)	19.6 (173)	19.6 (173)	19.6 (173)	19.6 (173)	19.6 (173)	19.6 (173)	19.6 (173)	19.6 (173)	19.6 (173)	19.6 (200)										
Rotational direction		Reverse to motor rotational direction			Same as motor rotational direction																					

Refer to pages B-444 and B-445 for the allowable shaft torque of the heavy-duty gearhead.
 Refer to page B-446 for the allowable shaft torque of the right-angle shaft type gearhead.

Connection diagram

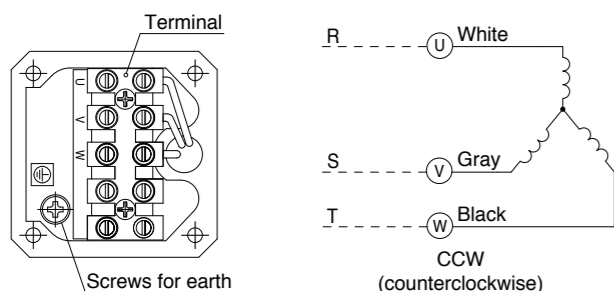

Change any two lead wires of U, V and W for CW rotation.

Speed-torque characteristics

M9MZ90GK4Y

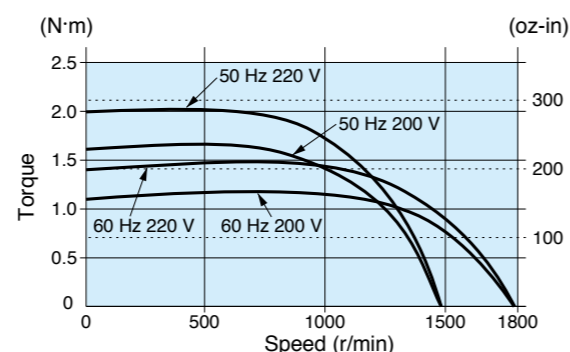

* Please read your User's manual carefully so that you will understand the operation and safety precautions before attempting to operate the system.

Features B-126 System configuration B-127 Coding system B-127 Model list B-128

Motor (dimensions)

M9MZ90GK4Y 4P 90 W 200 V / 220 V (with fan)

Scale: 1/4, Unit: mm (inch)

Mass 3.3 kg (7.28 lb)
 Helical gear
 Module 0.6
 Number of teeth 9

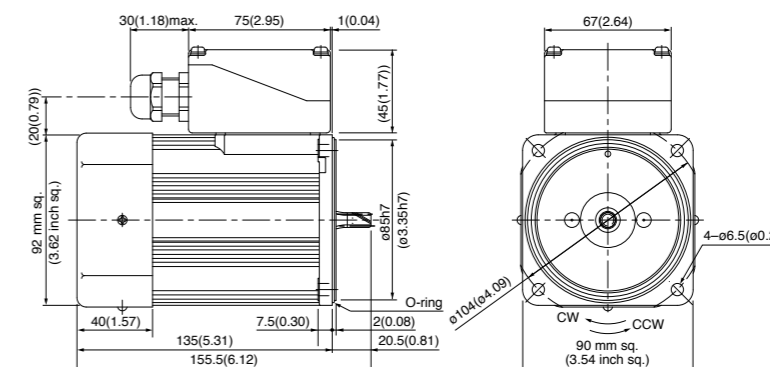

* Diameter of applicable cable to be ø8(ø0.31) to ø12(ø0.47).

Gear head (dimensions)

Scale: 1/4, Unit: mm (inch)

MZ9G□B (ball bearing / hinge not attached)
 Mass 1.4 kg (3.09 lb)

MY9G□B (ball bearing / hinge attached)
 Mass 1.4 kg (3.09 lb)

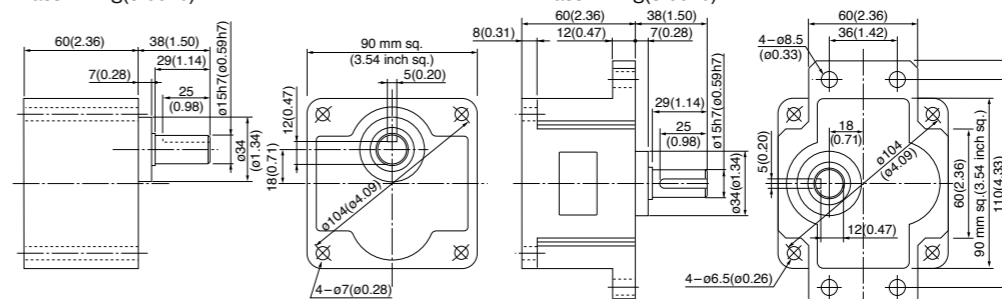

See page B-444 for the dimensional drawing of the heavy-duty gearhead.
 See page B-446 for the dimensional drawing of the right-angle shaft type gearhead.

Note) MZ / MY is available for a gear head of either type.
 (Note) Because the dimensions may be subject to change, also check the determinate dimensions if the gear head is to be used for design.

Gear head combination B-163 Round shaft motor B-165 Decimal gear head B-448 Gear head -inch (U.S.A.) B-449 Controls C-4 Option D-2

Key and keyway (dimensions) [attachment]

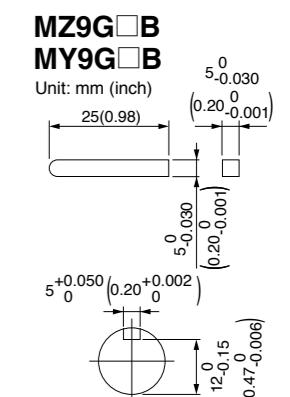

3-phase motor (sealed connector)

90 mm (3.54 inch) sq. 90 W

Specifications

Size	Motor model No.	Number of pole (P)	Output (W)	Voltage (V)	Frequency (Hz)	Rating (min)	Rating				Starting current (A)	Starting torque N-m (oz-in)
							Input (W)	Current (A)	Speed (r/min)	Torque N-m (oz-in)		
90 mm sq.	M9MZ90GK4YG M9MZ90GK4YGA	4	90	200	50	Cont.	142	0.62	1350	0.63 (89.2)	2.0	1.6 (227)
					60		138	0.56	1625	0.53 (75.1)	1.8	1.1 (156)
				230	60	137	0.56	1650	0.52 (73.6)	2.0	1.4 (198)	
					60	137	0.58	1675	0.51 (72.2)	2.1	1.6 (227)	
	M9MZ90GK4CG * M9MZ90GK4CGA	4	90	380	50	Cont.	144	0.31	1325	0.65 (92.0)	1.0	1.4 (198)
				400	50		144	0.31	1350	0.64 (90.6)	1.0	1.6 (227)

* Do not use an inverter to drive 380 V/400 V motor. (The surge voltage due to the switching of the inverter causes, the motor to withstand pressure failure.)
 • The specifications and wire connections of the round shaft motor are the same as those of the pinion shaft type. For the dimensional outline drawing, refer to page B-165.
 • The models with a motor model number to which "A" is suffixed are not sold or available in Japan.
 • For the combination of motor and gearhead, refer to pages B-128 and B-129 of applicable gearheads in the model list.

Permissible torque at output shaft of gear head

* The speed shown below is a calculated value based on the synchronous rotational speed. Depending on the load, the speed is less than the indicated value by 2 % to 20 %.

Unit of permissible torque: upper (N·m) / lower (lb-in)

Reduction ratio	Speed (r/min)																										
	50 Hz	60 Hz	500	416.7	300	250	200	166.7	150	120	100	83.3	75	60	50	41.7	30	25	20	16.7	15	12.5	10	8.3	7.5		
Applicable gear head	MZ9G3B to MZ9G200B (ball bearing / hinge not attached)	50 Hz	1.37 (12.1)	1.67 (14.8)	2.25 (19.9)	2.74 (24.3)	3.43 (30.4)	4.12 (36.5)	4.51 (39.9)	5.68 (50.3)	6.76 (59.8)	8.04 (71.2)	9.02 (79.8)	10.9 (96.5)	13.0 (115)	15.7 (139)	19.6 (173)										
		60 Hz	1.18 (10.4)	1.37 (12.1)	1.86 (16.5)	2.25 (19.9)	2.84 (25.1)	3.43 (30.4)	3.72 (32.9)	4.70 (41.6)	5.68 (50.3)	6.76 (59.8)	7.55 (66.8)	9.21 (81.5)	10.9 (96.5)	13.0 (115)	18.3 (162)	19.6 (173)									
Rotational direction	Same as motor rotational direction						Reverse to motor rotational direction						Same as motor rotational direction														

Permissible torque at output shaft of gear head using decimal gear head

* For external dimensions of the decimal gear head, refer to page B-448.

Applicable gear head		Reduction ratio	Speed (r/min)															
Bearing	Decimal gear head		50 Hz	60 Hz	250	300	360	500	600	750	900	1000	1200	1500	1800	2000		
MZ9G□B (ball bearing / hinge not attached)	MZ9G10XB	Permissible torque	19.6 (173)	19.6 (173)	19.6 (173)	19.6 (173)	19.6 (173)	19.6 (173)	19.6 (173)	19.6 (173)	19.6 (173)	19.6 (173)	19.6 (173)	19.6 (173)	19.6 (173)	19.6 (173)		
		N·m (lb-in)	19.6 (173)	19.6 (173)	19.6 (173)	19.6 (173)	19.6 (173)	19.6 (173)	19.6 (173)	19.6 (173)	19.6 (173)	19.6 (173)	19.6 (173)	19.6 (173)	19.6 (173)	19.6 (173)	19.6 (173)	
MY9G□B (ball bearing / hinge attached)		Rotational direction	Reverse to motor rotational direction						Same as motor rotational direction									

Refer to pages B-444 and B-445 for the allowable shaft torque of the heavy-duty gearhead.
Refer to page B-446 for the allowable shaft torque of the right-angle shaft type gearhead.

Connection diagram

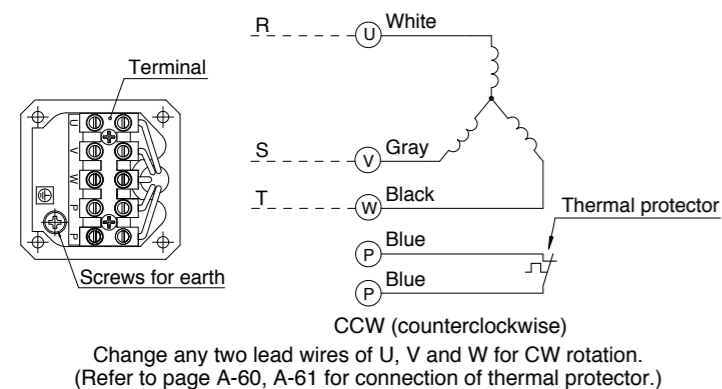

Speed-torque characteristics

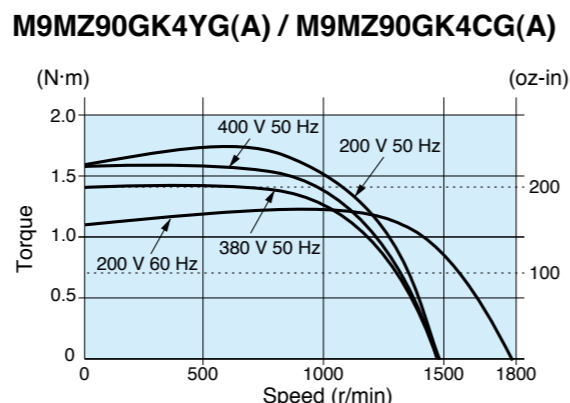

* Please read your User's manual carefully so that you will understand the operation and safety precautions before attempting to operate the system.

[Features B-126](#)
[System configuration B-127](#)
[Coding system B-127](#)
[Model list B-128](#)

Motor (dimensions)

Scale: 1/4, Unit: mm (inch)

M9MZ90GK4YG(A) 4P 90 W 200 V / 220 V / 230 V (with fan)
M9MZ90GK4CG(A) 4P 90 W 380 V / 400 V (with fan)

Mass **3.3 kg (7.28 lb)**
 Helical gear
 Module **0.6**
 Number of teeth **9**

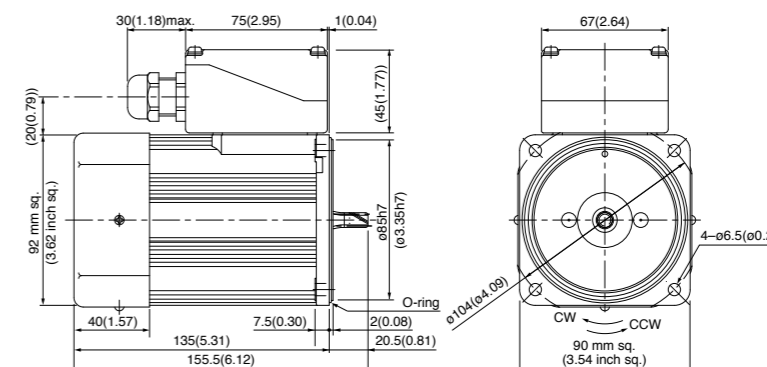

* Diameter of applicable cable to be $\phi 8(\phi 0.31)$ to $\phi 12(\phi 0.47)$.

Gear head (dimensions)

Scale: 1/4, Unit: mm (inch)

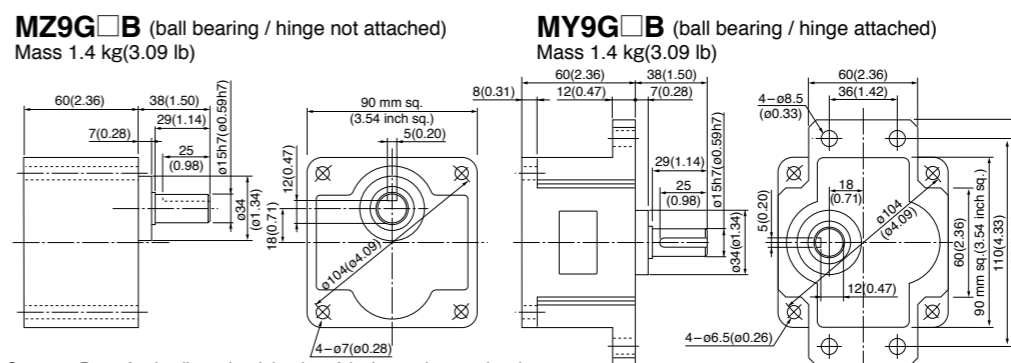

See page B-444 for the dimensional drawing of the heavy-duty gearhead.
See page B-446 for the dimensional drawing of the right-angle shaft type gearhead.

Note) MZ / MY is available for a gear head of either type.
(Note) Because the dimensions may be subject to change, also check the determinate dimensions if the gear head is to be used for design.

[Gear head combination B-163](#)
[Round shaft motor B-165](#)
[Decimal gear head B-448](#)
[Gear head -inch \(U.S.A.\) B-449](#)
[Controls C-4](#)
[Option D-2](#)

Key and keyway (dimensions) [attachment]

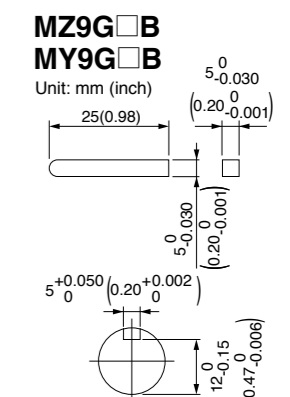

3-phase motor (leadwire)

Gear head combination dimensions

Scale: 1/4, Unit: mm (inch)

* Gear head is sold separately.

80 mm sq. (3.15 inch sq.) 25 W

M8MX25G4Y + MX8G□B(M)
M8MX25G4YG(A) + MX8G□B(M)

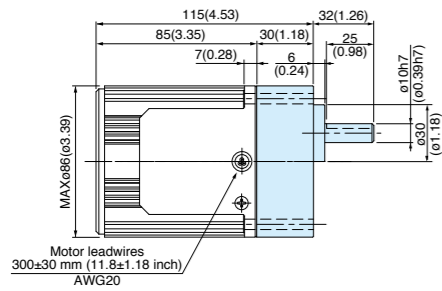

90 mm sq. (3.54 inch sq.) 40 W

M9MX40G4Y + MX9G□B(M)
M9MX40G4YG(A) + MX9G□B(M)

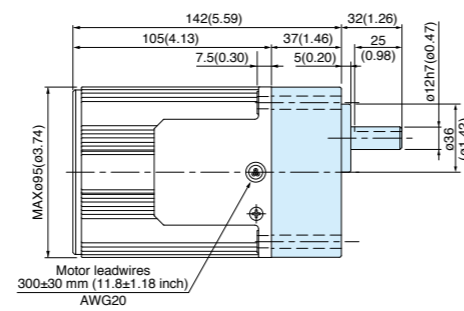

90 mm sq. (3.54 inch sq.) 60 W

M9MZ60G4Y + MZ9G□B (MY9G□B)
M9MZ60G4YG(A) + MZ9G□B (MY9G□B)

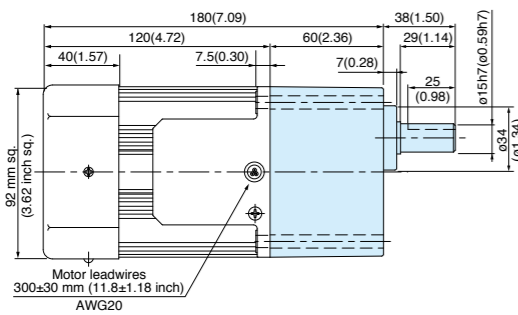

* Refer to page B-444 for high torque gear head.

90 mm sq. (3.54 inch sq.) 90 W

M9MZ90G4Y + MY9G□B (MZ9G□B)
M9MZ90G4YG(A) + MY9G□B (MZ9G□B)

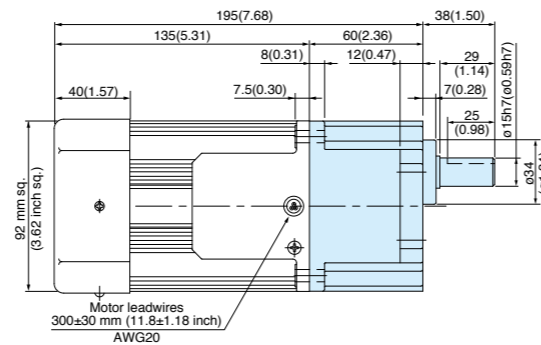

* Refer to page B-444 for high torque gear head.

3-phase motor (sealed connector)

Gear head combination dimensions

Scale: 1/4, Unit: mm (inch)

* Gear head is sold separately.

80 mm sq. (3.15 inch sq.) 25 W

M8MX25GK4Y + MX8G□B(M)
M8MX25GK4YG(A) + MX8G□B(M)
M8MX25GK4CG(A) + MX8G□B(M)

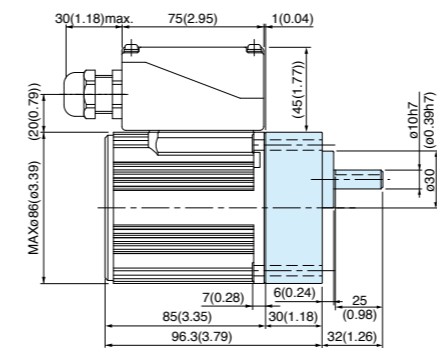

* Diameter of applicable cable to be $\phi 8(\phi 0.31)$ to $\phi 12(\phi 0.47)$.

90 mm sq. (3.54 inch sq.) 40 W

M9MX40GK4Y + MX9G□B(M)
M9MX40GK4YG(A) + MX9G□B(M)
M9MX40GK4CG(A) + MX9G□B(M)

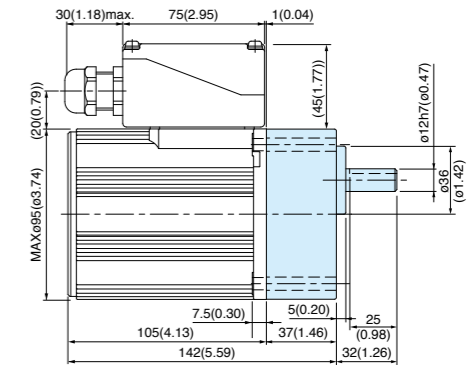

* Diameter of applicable cable to be $\phi 8(\phi 0.31)$ to $\phi 12(\phi 0.47)$.

90 mm sq. (3.54 inch sq.) 60 W

M9MZ60GK4Y + MZ9G□B (MY9G□B)
M9MZ60GK4YG(A) + MZ9G□B (MY9G□B)
M9MZ60GK4CG(A) + MZ9G□B (MY9G□B)

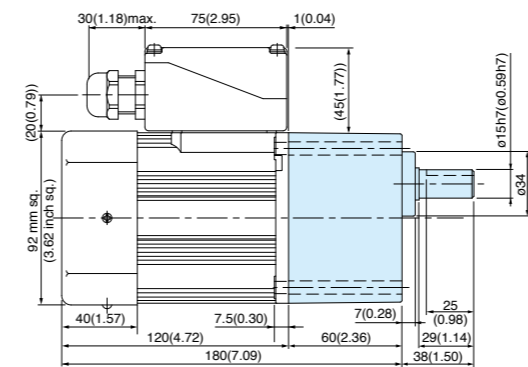

* Diameter of applicable cable to be $\phi 8(\phi 0.31)$ to $\phi 12(\phi 0.47)$.

* Refer to page B-444 for high torque gear head.

90 mm sq. (3.54 inch sq.) 90 W

M9MZ90GK4Y + MY9G□B (MZ9G□B)
M9MZ90GK4YG(A) + MY9G□B (MZ9G□B)
M9MZ90GK4CG(A) + MY9G□B (MZ9G□B)

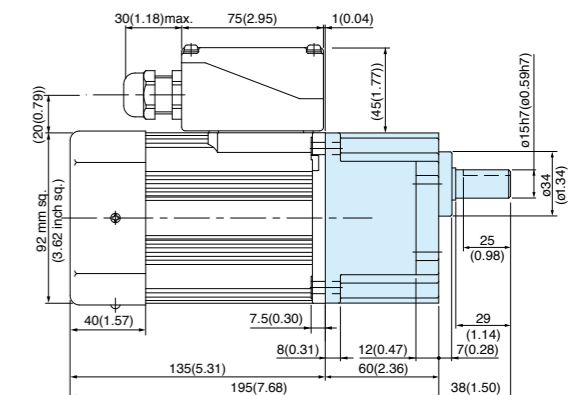

* Diameter of applicable cable to be $\phi 8(\phi 0.31)$ to $\phi 12(\phi 0.47)$.

* Refer to page B-444 for high torque gear head.

* Please read your User's manual carefully so that you will understand the operation and safety precautions before attempting to operate the system.

Features B-126 System configuration B-127 Coding system B-127 Model list B-128

*The models with a motor model number to which "A" is suffixed are not sold or available in Japan.

(Note) Because the dimensions may be subject to change, also check the determinate dimensions if the gear head is to be used for design.

Specifications B-130 to B-161 Controls C-4 Option D-2

Induction motor
Reversible motor
3-phase motor
Electromagnetic brake motor
Variable speed induction motor
Variable speed reversible motor
Variable speed electromagnetic brake single-phase motor
Variable speed unit motor
C&B motor
2-pole round shaft motor
Gear head
Gear head -inch (U.S.A.)

3-phase motor (4-pole round shaft / leadwire)

Dimensions
Scale: 1/4, Unit: mm (inch)

80 mm sq. (3.15 inch sq.) 25 W **Mass**
1.5 kg (3.31 lb)
M8MX25S4YS
M8MX25S4YG(A)

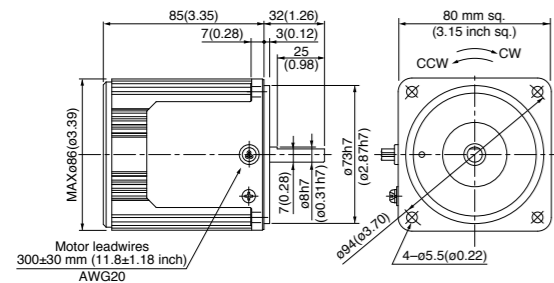

90 mm sq. (3.54 inch sq.) 40 W **Mass**
2.4 kg (5.29 lb)
M9MX40S4YS
M9MX40S4YG(A)

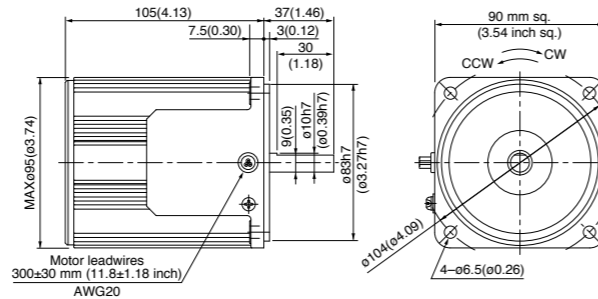

90 mm sq. (3.54 inch sq.) 60 W **Mass**
2.7 kg (5.95 lb)
M9MZ60S4YS (with fan)
M9MZ60S4YG(A) (with fan)

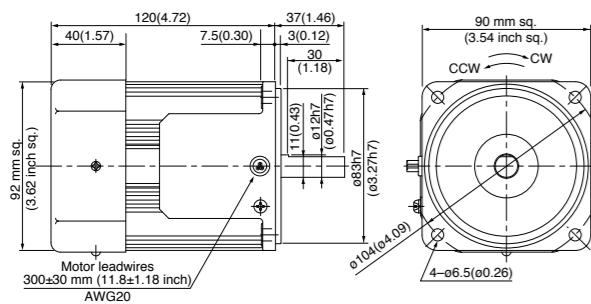

90 mm sq. (3.54 inch sq.) 90 W **Mass**
3.2 kg (7.05 lb)
M9MZ90S4YS (with fan)
M9MZ90S4YG(A) (with fan)

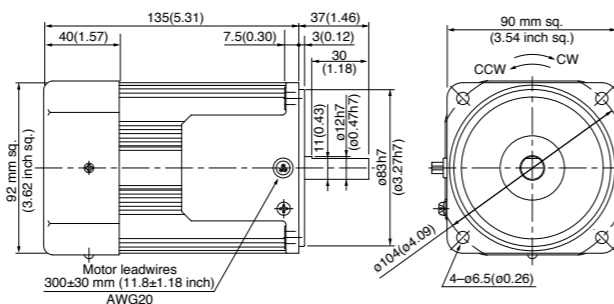

* Please refer to the pinion shaft motor for wiring and specifications of the motor.

* Please read your User's manual carefully so that you will understand the operation and safety precautions before attempting to operate the system.

Features B-126 System configuration B-127 Coding system B-127 Model list B-128

3-phase motor (4-pole round shaft / sealed connector)

Dimensions
Scale: 1/4, Unit: mm (inch)

80 mm sq. (3.15 inch sq.) 25 W **Mass**
1.8 kg (3.97 lb)
M8MX25SK4YS
M8MX25SK4YG(A)
M8MX25SK4CG(A)

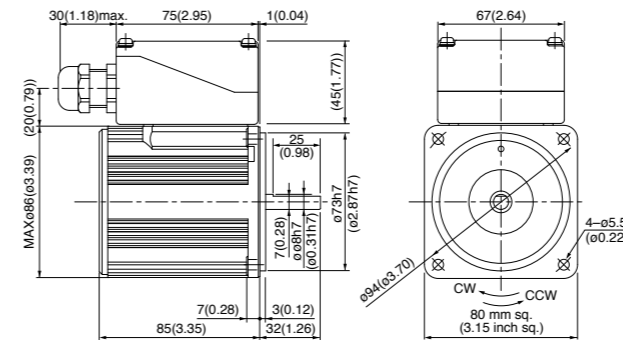

* Diameter of applicable cabtyre cable to be ø8(ø0.31) to ø12(ø0.47).

90 mm sq. (3.54 inch sq.) 40 W **Mass**
2.8 kg (6.17 lb)
M9MX40SK4YS
M9MX40SK4YG(A)
M9MX40SK4CG(A)

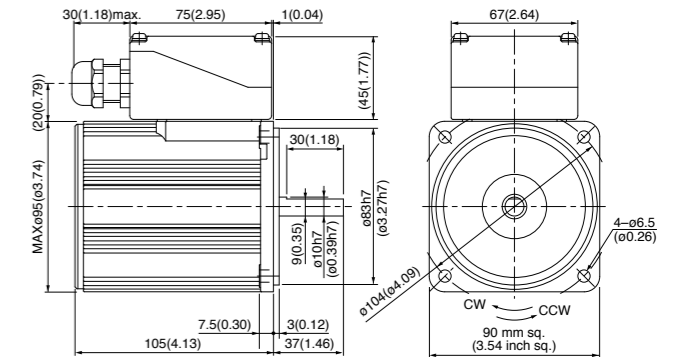

* Diameter of applicable cabtyre cable to be ø8(ø0.31) to ø12(ø0.47).

90 mm sq. (3.54 inch sq.) 60 W **Mass**
3.0 kg (6.61 lb)
M9MZ60SK4YS (with fan)
M9MZ60SK4YG(A) (with fan)
M9MZ60SK4CG(A) (with fan)

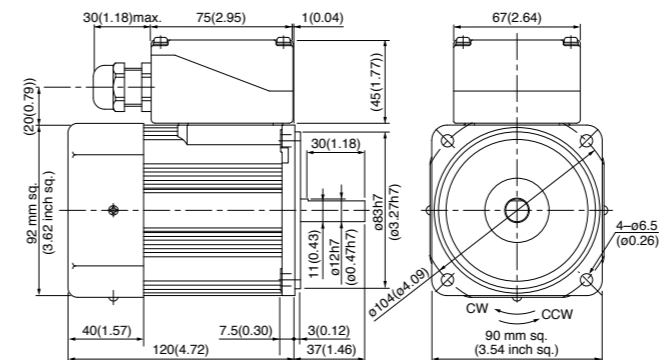

* Diameter of applicable cabtyre cable to be ø8(ø0.31) to ø12(ø0.47).

90 mm sq. (3.54 inch sq.) 90 W **Mass**
3.3 kg (7.28 lb)
M9MZ90SK4YS (with fan)
M9MZ90SK4YG(A) (with fan)
M9MZ90SK4CG(A) (with fan)

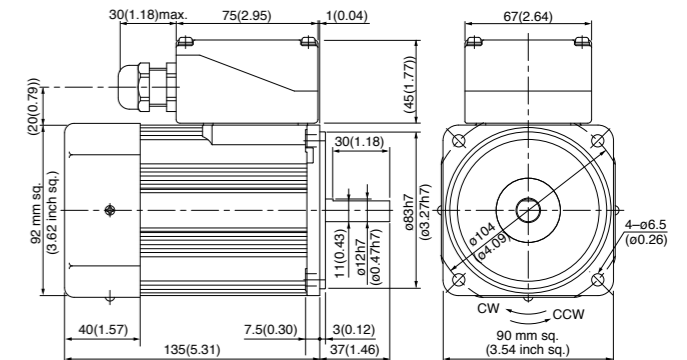

* Diameter of applicable cabtyre cable to be ø8(ø0.31) to ø12(ø0.47).

200 V/220 V/230 V round shaft motors with a sealed connector (with a terminal box) are covered by the Electrical Appliance and Material Safety Law. The indications on their nameplate are based on this law.

* Please refer to the pinion shaft motor for wiring and specifications of the motor.

*The models with a motor model number to which "A" is suffixed are not sold or available in Japan.

(Note) Because the dimensions may be subject to change, also check the determinate dimensions if the gear head is to be used for design.

Specifications B-130 to B-161 Controls C-4 Option D-2

Induction motor
Reversible motor
3-phase motor
Electromagnetic brake motor
Variable speed induction motor
Variable speed electromagnetic brake single-phase motor
Variable speed unit motor
C&B motor
2-pole round shaft motor
Gear head
Gear head -inch (U.S.A.)

