

REVISIONS			
LTR	DESCRIPTION	DATE	APPROVED
A	Changed manufacturer's eligibility.	24 Aug 1987	Steven B. Searcy
B	Changes in accordance with NOR 5945-R004-93	4 Aug 1993	R. Gosciniak
C	Cancel document	3 Mar 2000	Kendall Cottongim
D	Reinstate document	19 July 2002	Kendall Cottongim
E	Incorporated boilerplate updates. Modified can height of Figure 1. Added approved source of supply.	17 July 2008	Michael A. Radecki
F	Incorporate boilerplate updates. Added approved source of supply.	05 Nov 2012	Michael A. Radecki

CURRENT DESIGN ACTIVITY CAGE CODE 037Z3  
 DEFENSE LOGISTICS AGENCY  
 DLA LAND AND MARITIME  
 COLUMBUS, OHIO 43218-3990

Prepared in accordance with ASME Y14.100

Source control drawing

<b>REV STATUS OF PAGES</b>	<b>REV</b>	F	F	F	F	F	F	F	F	F	F							
	<b>PAGES</b>	1	2	3	4	5	6	7	8	9	10							

<b>PMIC N/A</b>	<b>PREPARED BY</b> Richard A. Yannitti		<b>DESIGN ACTIVITY</b> DEFENSE ELECTRONICS SUPPLY CENTER DAYTON, OH 45444-5000																
Original date of drawing  15 Aug 1985	<b>CHECKED BY</b> James R. Martin		<b>TITLE</b> RELAY, SOLID STATE, HERMETICALLY SEALED, OPTICALLY ISOLATED, 1.0 AMPERE, 60 V DC, SPST (N.O.), CMOS INPUT																
	<b>APPROVED BY</b> Steven B. Searcy																		
	<b>SIZE</b> A	<b>CODE IDENT. NO.</b> 037Z3		<b>DWG NO.</b>  <b>85006</b>															
	<b>REV</b> F		<b>PAGE</b> 1 <b>OF</b> 10																

1. SCOPE

1.1 Scope. This drawing describes the requirements for a hermetically sealed solid state relay supplied to the "Y" screening requirements of [MIL-PRF-28750](#).

1.2 Part or Identifying Number (PIN). The complete PIN shall be as follows:

85006  
|  
-----  
Drawing number

-01  
|  
-----  
Dash number

2. APPLICABLE DOCUMENTS

2.1 General. The documents listed in this section are specified in sections 3 and 4 of this specification. This section does not include documents cited in other sections of this specification or recommended for additional information or as examples. While every effort has been made to ensure the completeness of this list, document users are cautioned that they must meet all specified requirements of documents in [sections 3](#) and [4](#) of this specification, whether or not they are listed.

2.2 Government documents.

2.2.1 Specifications, standards, and handbooks. The following specifications, standards, and handbooks form a part of this document to the extent specified herein. Unless otherwise specified, the issues of these documents are those cited in the solicitation or contract.

DEPARTMENT OF DEFENSE SPECIFICATIONS

[MIL-PRF-28750](#)                      Relays, Solid State, General Specification for.

DEPARTMENT OF DEFENSE STANDARDS

- [MIL-STD-202](#)                      -    Electronic and Electrical Component Parts.
- [MIL-STD-883](#)                    -    Microelectronics.
- [MIL-STD-1285](#)                 -    Marking of Electrical and Electronic Parts, FSC: 59GP

2.3 Order of precedence. In the event of a conflict between the text of this document and the references cited herein, the text of this document takes precedence, unless otherwise noted. Nothing in this document, however, supersedes applicable laws and regulations unless a specific exemption has been obtained.

3. REQUIREMENTS

3.1 Item requirements. The individual item requirements shall be in accordance with [MIL-PRF-28750](#), and as specified herein.

3.2 Interface and physical dimensions. The interface and physical dimensions shall be as specified in [MIL-PRF-28750](#), and herein (see [figure 1](#)).

3.3 Input characteristics.

3.3.1 Input current. 16 milliamperes dc maximum.

3.3.2 Control voltage range. 3.8 V dc to 32 V dc maximum.

3.3.3 Rated turn on voltage. 5.0 V dc.

<b>DEFENSE ELECTRONICS SUPPLY CENTER DAYTON, OHIO</b>	SIZE <b>A</b>	CODE IDENT NO. <b>14933</b>	DWG NO. <b>85006</b>
		REV F	SHEET 2

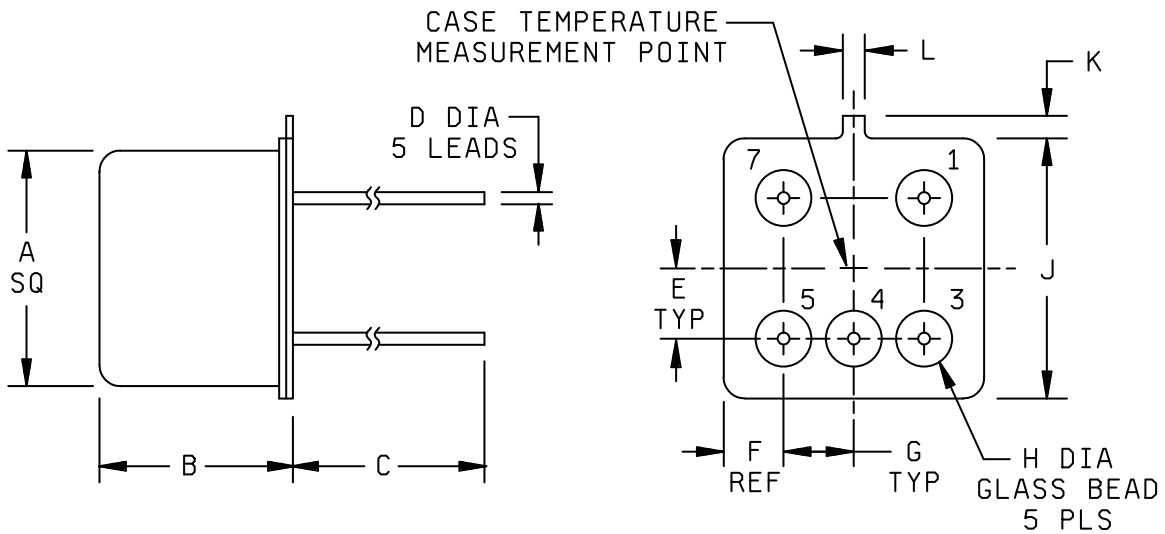

Ltr	Inches		Millimeter	
	Min	Max	Min	Max
A	---	.335	---	8.51
B	---	.290	---	7.37
C	.70	---	17.8	---
D	.016	.019	0.41	0.48
E	.090	.110	2.29	2.79
F	.080	.090	2.03	2.29
G	.090	.110	2.29	2.79
H	.070	.090	1.78	2.29
J	---	.370	---	9.40
K	.030	.034	0.76	0.86
L	.029	.033	0.74	0.84

NOTES;

1. Dimensions are in inches.
2. Metric equivalents are given for general information only.
3. Unless otherwise specified, tolerances are  $\pm 0.005$  (0.13 mm) for three place decimals and  $\pm 0.01$  (0.3 mm) for two place decimals.
4. Circuit diagram shown on part is terminal view.

FIGURE 1. Outline dimensions and configuration.

<b>DEFENSE ELECTRONICS SUPPLY CENTER DAYTON, OHIO</b>	SIZE <b>A</b>	CODE IDENT NO. <b>14933</b>	DWG NO. <b>85006</b>
		REV F	SHEET 3

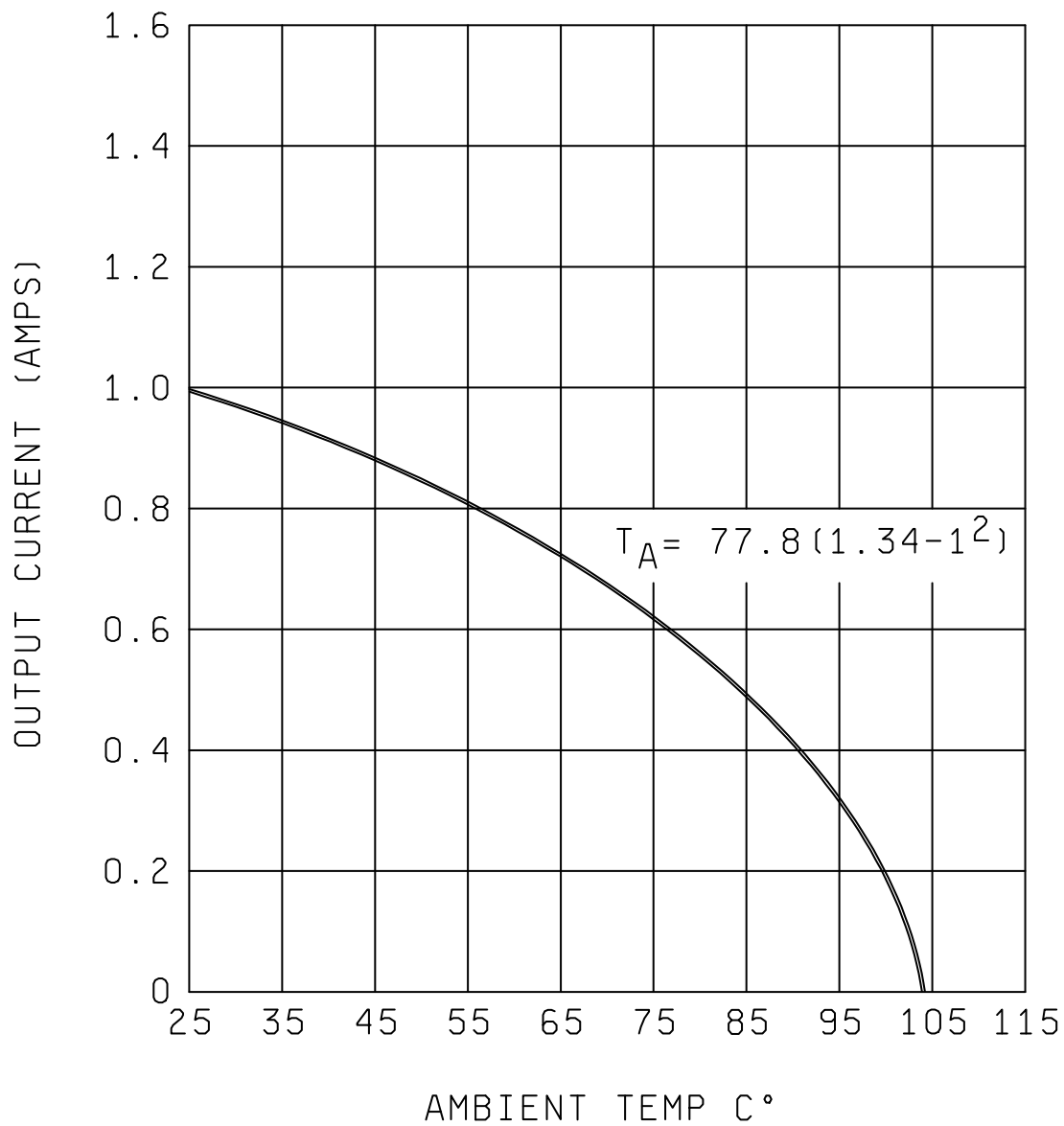
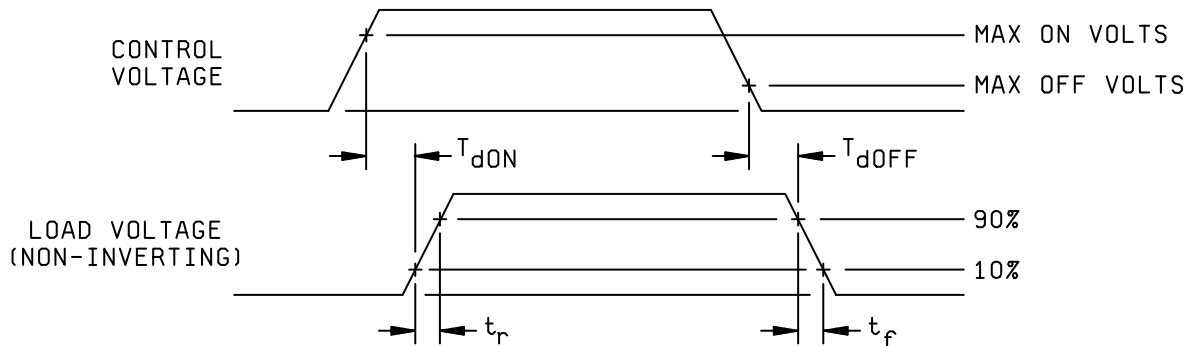

FIGURE 2. Output current versus ambient temperature.

<b>DEFENSE ELECTRONICS SUPPLY CENTER</b> <b>DAYTON, OHIO</b>	<b>SIZE</b> <b>A</b>	<b>CODE IDENT NO.</b> <b>14933</b>	<b>DWG NO.</b> <b>85006</b>
		<b>REV F</b>	<b>SHEET 4</b>



NOTES:

1.  $t_{ON} = t_{dON} + t_r$ .
2.  $t_{OFF} = t_{dOFF} + t_f$ .

FIGURE 3. Turn-on and turn-off time waveform.

<b>DEFENSE ELECTRONICS SUPPLY CENTER</b> <b>DAYTON, OHIO</b>	<b>SIZE</b> <b>A</b>	<b>CODE IDENT NO.</b> <b>14933</b>	<b>DWG NO.</b> <b>85006</b>
		<b>REV F</b>	<b>SHEET 5</b>

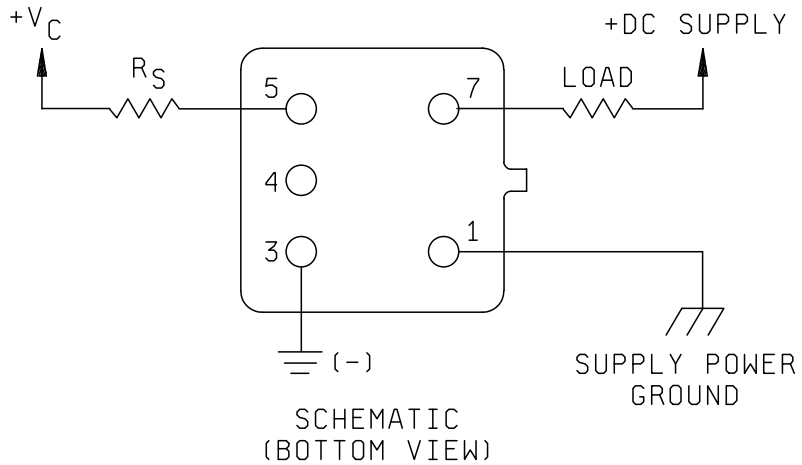

$V_C$ RANGE	$R_S$ OHMS	POWER RATING WATTS
3.8 - 6 V	NOT REQUIRED	
6 - 10 V	300	0.25
10 - 14 V	620	0.25
14 - 18 V	910	0.50
18 - 22 V	1200	0.5
22 - 26 V	1500	0.50
26 - 32 V	2000	1.0

NOTE: Limiting resistor required over 6 volts (see table above) when not used with a heat sink; with a heat sink, the values are to be determined.

FIGURE 4. Wiring diagram.

<b>DEFENSE ELECTRONICS SUPPLY CENTER DAYTON, OHIO</b>	SIZE <b>A</b>	CODE IDENT NO. <b>14933</b>	DWG NO. <b>85006</b>
		REV F	SHEET 6

3.3.4 Maximum turn-off voltage (assured). 1.5 V dc maximum. [1/](#)

3.3.5 Minimum turn-on voltage (assured). 3.8 V dc minimum. [1/](#)

3.3.6 Reverse polarity. 32 V dc maximum.

3.4 Output characteristics.

3.4.1 Continuous operating output voltage (maximum). 60 V dc maximum.

3.4.2 Output current at 25°C. 1.0 ampere dc maximum.

3.4.2.1 Rated output current. See [figure 2](#).

3.4.3 Output capacitance. 700 pF at 25 V ac, 1 MHz, superimposed.

3.4.3.1 Input-output capacitance. 5 pF maximum, 1 KHz.

3.4.4 Output leakage current. 10 microamperes dc maximum at 60 V dc, -55°C to +25°C. 40 microamperes maximum at 30 V dc, 100°C. Allow 10 seconds for measurement to settle.

3.4.5 Transient voltage. 80 V dc maximum, 5 seconds maximum pulse duration (leakage less than 1.0 mA).

3.4.6 On resistance. .3 ohm maximum (measured at 100 mA at 25°C.)

NOTE: For on state resistance at temperatures other than 25°C, use the following equation:

$$R = R_{25} \times e^{0.006 \times \%T}$$

where:  $R_{25}$  = resistance at 25°C from [figure 4](#).

R = resistance at new temperature

%T = new temperature - 25°C

e = 2.7182818

3.4.7 Output voltage drop. 0.5 V dc maximum.

3.4.8 Short circuit protection.

3.4.8.1 Relay will not be damaged by a short on the load during normal operation or by being turned on into a shorted load.

3.4.8.2 Relay will not be damaged by continuous overload condition.

3.4.8.3 To return unit to normal operating condition, remove short circuit or overload condition. Then remove and reapply input control voltage or remove and reapply load voltage.

3.4.9 Overload. 200 percent of rated current for 50 milliseconds.

<b>DEFENSE ELECTRONICS SUPPLY CENTER DAYTON, OHIO</b>	<b>SIZE</b>	<b>CODE IDENT NO.</b>	<b>DWG NO.</b>
	<b>A</b>	<b>14933</b>	<b>85006</b>
		REV F	SHEET 7

3.5 Electrical characteristics.

3.5.1 Dielectric withstanding voltage. 1,000 V rms (input to output to case).

3.5.2 Insulation resistance. 1,000 megohms (input to case at 500 V dc).

3.5.3 Turn-on time (t<sub>ON</sub>). 1.8 milliseconds maximum (see [figure 3](#)).

3.5.4 Turn-off time (t<sub>OFF</sub>). 1.1 milliseconds maximum (see [figure 3](#)).

3.5.5 Maximum repetitive rate. 20 Hz, 50 percent duty cycle.

3.5.6 On-resistance. 0.52 ohm maximum and 0.225 ampere.

3.5.7 Electromagnetic interference. Applicable.

3.6 Environmental characteristics.

3.6.1 Operating temperature range. -55°C to +100°C.

3.6.2 Storage temperature range. -55°C to +125°C.

3.6.3 Shock. [MIL-STD-202](#), method 213, test condition F, 1,500 G's for 0.5 millisecond. Relays shall have rated turn on voltage applied.

3.6.4 Vibration. [MIL-STD-202](#), method 204, test condition D 100 G's, 10 to 3,000 Hz. Relays shall have rated turn voltage applied.

3.6.5 Acceleration. [MIL-STD-883](#), method 2001, test condition A, 5,000 G's, Y1 axis.

3.6.6 Seal (hermetic). [MIL-STD-883](#), method 1014, test condition B.

3.7 Physical. Physical requirements shall be as specified herein.

3.7.1 Weight. 2 grams (0.07 ounce) maximum.

3.7.2 Wiring diagram. See [figure 4](#).

3.8 Marking. Marking shall be in accordance with [MIL-PRF-28750](#) except the PIN shall be in accordance with [1.2](#) herein. The "M28750/X-XXX" part number shall not be used.

3.9 Assurance requirements. Relays furnished under this drawing shall have been subjected to, and passed all the requirements, tests, and inspections detailed herein.

3.9.1 Conformance inspection. Conformance inspection shall be in accordance with [MIL-PRF-28750](#) and [4.2](#) herein.

3.10 Recycled, recovered, or environmentally preferable materials. Recycled, recovered, or environmentally preferable materials should be used to the maximum extent possible provided that the material meets or exceeds the operational and maintenance requirements, and promotes economically advantageous life cycle costs.

3.11 Manufacturer eligibility. To be eligible for listing as an approved source of supply, a manufacturer shall be listed on the MIL-PRF-28750 Qualified Product List for at least one part, or perform the Group A inspection specified herein on a sample of parts agreed upon by the manufacturer and DLA Land and Maritime-VA.

<b>DEFENSE ELECTRONICS SUPPLY CENTER</b> <b>DAYTON, OHIO</b>	<b>SIZE</b>	<b>CODE IDENT NO.</b>	<b>DWG NO.</b>
	<b>A</b>	<b>14933</b>	<b>85006</b>
		<b>REV F</b>	<b>SHEET 8</b>

3.12 Certificate of compliance. A certificate of compliance shall be required from a manufacturer in order to be listed as an approved source of supply (see 6.6).

3.13 Pure tin. The use of pure tin, as an underplate or final finish is prohibited both internally and externally. Tin content of components and solder shall not exceed 97 percent, by mass. Tin shall be alloyed with a minimum of 3 percent lead, by mass (see 6.5).

3.14 Marking. Marking shall be in accordance with MIL-STD-1285, except the relay shall be marked with the PIN as specified herein (see 1.2), the manufacturer's name of Commercial and Government Entity (CAGE) code, and date lot codes.

3.15 Workmanship. The relay shall be uniform in quality and free from any defects that will affect life, serviceability, or appearance.

#### 4. VERIFICATION

4.1 Sampling and inspection. Sampling and inspection procedures shall be in accordance with MIL-PRF-28750, except as modified herein.

4.2 Conformance inspection. Conformance inspection shall be in accordance with group A listing of MIL-PRF-28750. Group A testing shall be performed on each inspection lot and manufacturers shall keep lot records for 3 years (minimum), monitor for compliance to the prescribed procedures, and observe that satisfactory manufacturing conditions and records on lots are maintained for these relays.

4.2.1 Group A inspection. Group A inspection shall consist of all tests specified in MIL-PRF-28750 for the "Y" screening level, components used internally to the relay shall not require hermetic packaging. Temperature range for screening tests shall be as specified in 3.6.1.

#### 5. PACKAGING

5.1 Packaging. For acquisition purposes, the packaging requirements shall be as specified in the contract or order (see 6.2). When packaging of materiel is to be performed by DoD or in-house contractor personnel, these personnel need to contact the responsible packaging activity to ascertain packaging requirements. Packaging requirements are maintained by the Inventory Control Point's packaging activities within the Military Service or Defense Agency, or within the military service's system commands. Packaging data retrieval is available from the managing Military Department's or Defense Agency's automated packaging files, CD-ROM products, or by contacting the responsible packaging activity.

#### 6. NOTES

(This section contains information of a general or explanatory nature which may be helpful, but is not mandatory.)

6.1 Intended use. Relays conforming to this drawing are intended for use when military specifications do not exist and qualified military devices that will perform the required function are not available for O.E.M. application. This drawing is intended exclusively to prevent the proliferation of unnecessary duplicate specifications, drawings, and stock catalog listings. When a military specification exists and the product covered by this drawing has been qualified for listing on QPL-28750, this drawing will become inactive for new design. The QPL-28750 product shall be the preferred item for all applications.

6.2 Ordering data. The contract or purchase order should specify the following:

- a. Complete PIN (see 1.2).
- b. Requirements for delivery of one copy of the conformance inspection data or the certificate of compliance that parts have passed conformance inspection with each shipment of parts by the manufacturer.
- c. Requirements for packaging and packing.

6.3 Replaceability. Relays covered by this drawing will replace the same generic device covered by a contractor-prepared specification or drawing.

<b>DEFENSE ELECTRONICS SUPPLY CENTER DAYTON, OHIO</b>	<b>SIZE</b>	<b>CODE IDENT NO.</b>	<b>DWG NO.</b>
	<b>A</b>	<b>14933</b>	<b>85006</b>
		<b>REV F</b>	<b>SHEET 9</b>

6.4 Tin whisker growth. The use of alloys with tin content greater than 97 percent, by mass, may exhibit tin whisker growth problems after manufacture. Tin whiskers may occur anytime from a day to years after manufacture and can develop under typical operating conditions, on products that use such materials. Conformal coatings applied over top of a whisker-prone surface will not prevent the formation of tin whiskers. Alloys of 3 percent lead, by mass, have shown to inhibit the growth of tin whiskers. For additional information on this matter, refer to [ASTM-B545](#) (Standard Specification for Electrodeposited Coatings of Tin).

6.5 Users of record. Coordination of this document for future revisions is coordinated only with the approved source(s) of supply and the users of record of this document. Requests to be added as a recorded user of this drawing may be achieved online at <mailto:relay@dla.mil> or if in writing to: DLA Land and Maritime, ATTN: DLA Land and Maritime/VAT, Post Office Box 3990, Columbus, OH 43218-3990 or by telephone (614) 692-4481 or DSN 850-4481.

6.6 Approved source(s) of supply. Approved source(s) of supply are listed herein. Additional sources will be added as they become available. Assistance in the use of this drawing may be obtained online at <mailto:relay@dla.mil>, or by contacting DLA Land and Maritime, Columbus, ATTN: DLA Land and Maritime-VAT, Post Office Box 3990, Columbus, OH 43218-3990 or by telephone (614) 692-4481 or DSN 850-4481.

DLA Land and Maritime drawing PIN	Vendor similar designation or type number <u>1/</u>	Vendor CAGE	Vendor name and address
85006-001	53012	31757	Micropac Industries, Incorporated 905 E. Walnut Street Garland, TX 75040 Phone (214) 272-3571
85006-001	MS17-2000	58614	TE Connectivity DBA CII Technologies 1396 Charlotte Way Fairview, NC 28730 Phone (800) 806-0480  <u>Plant:</u> Philip Engineering Corporation 3 Peerless Way, Unit C Enfield, CT 06082-2371 Phone (860) 265-3744

1/ Parts must be purchased to the DLA Land and Maritime PIN to assure that all performance requirements and tests are met.

<b>DEFENSE ELECTRONICS SUPPLY CENTER DAYTON, OHIO</b>	<b>SIZE A</b>	<b>CODE IDENT NO. 14933</b>	<b>DWG NO. 85006</b>
		<b>REV F</b>	<b>SHEET 10</b>