

# AS85049/14S Self-Locking E-Nut



AS85049

B

CONNECTOR DESIGNATOR:	
<b>H</b>	MIL-DTL-38999 Series III & IV EN36455

Finish
<i>A</i> = Anodize, Black
<i>N</i> = Electroless Nickel
<i>W</i> = 1,000 Hour Cadmium Olive Drab over Electroless Nickel
<i>X</i> = Pure Dense Electrodeposited Aluminum
<i>Y</i> = Passivated
<i>Z</i> = Zinc-Nickel, Black

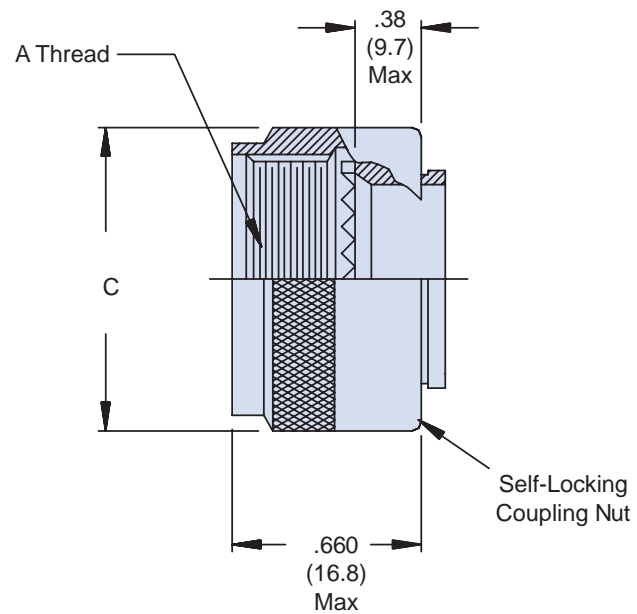
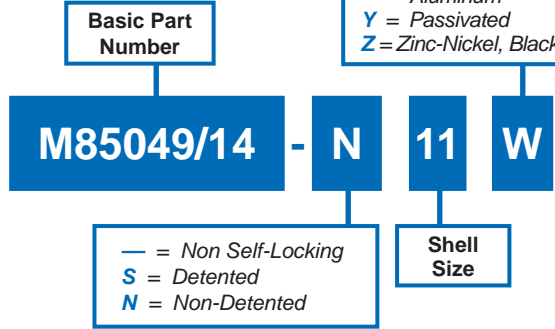

Shell Size	Shell Size Code Ref.	A Thread Class 2B	Ø C Max	
9	A	M12 X 1 - 6H	.86	(21.8)
11	B	M15 X 1 - 6H	.98	(24.9)
13	C	M18 X 1 - 6H	1.16	(29.5)
15	D	1M22 X 1 - 6H	1.28	(32.5)
17	E	M25 X 1 - 6H	1.41	(35.8)
19	F	M28 X 1 - 6H	1.52	(38.6)
21	G	M31 X 1 - 6H	1.64	(41.7)
23	H	M34 X 1 - 6H	1.77	(45.0)
25	J	M37 X 1 - 6H	1.89	(48.0)

- APPLICATION NOTES**
- For complete dimensions, see the applicable Military Specification.
  - Metric dimensions (mm) are indicated in parentheses.

Dimensions in inches (millimeters) and are subject to change without notice.