



M7100

Pressure Transducer

SPECIFICATIONS

- ◆ Performance standard on and off highway engine and vehicle OEMs
- ◆ Rugged for heavy equipment and outdoor use
- ◆ Designed specifically for high volume applications
- ◆ Stainless steel wetted surfaces
- ◆ Medium to high pressures
- ◆ CE Approved
- ◆ UL Certified
- ◆ Gage

FEATURES

- ◆ Hermetic Pressure Ports
- ◆ Integral Electrical Connector
- ◆ Survives High Vibration
- ◆ $\pm 0.25\%$ Accuracy
- ◆ Water Resistant 1M Immersion

APPLICATIONS

- ◆ On and Off Highway Engines and Vehicles
- ◆ HVAC Refrigeration Controls
- ◆ Compressors
- ◆ Hydraulics
- ◆ Energy and Water Management

The M7100 pressure transducer from the Microfused line of MEAS sets a new price performance standard for demanding engine and vehicle, and industrial applications. This transducer is suitable for measurement of liquid or gas pressure, even for difficult media such as contaminated water, steam and corrosive fluids.

The transducer pressure cavity is machined from a solid piece of 17-4 PH stainless steel. The standard version includes a 1/4 NPT pipe thread allowing a leak-proof, all metal sealed system. There are no o-rings or organics exposed to the pressure media and the durability is excellent. This automotive grade pressure transducer with stainless steel hermetic pressure ports and integral electrical connector can boast up to 10,000psi (700Bar). The M7100 is UL certified and exceeds the latest industrial CE requirements including surge protection and is overvoltage protected in both positive and reverse polarity.

STANDARD RANGES

Range (psi)	Range (Bar)	Gage
0 to 150	0 to 010	♦
0 to 200	0 to 014	♦
0 to 300	0 to 020	♦
0 to 500	0 to 035	♦
0 to 01K	0 to 070	♦
0 to 1K5	0 to 100	♦
0 to 03K	0 to 200	♦
0 to 05K	0 to 350	♦
0 to 7K5	0 to 500	♦
0 to 10K	0 to 700	♦

PERFORMANCE SPECIFICATIONS

Ambient Temperature: 25°C (unless otherwise specified);

PARAMETERS	MIN		TYP	MAX		UNITS	NOTES
	Short	Long		Short	Long		
Load Resistance	10					KΩ	
Accuracy (combined linearity, hysteresis & repeatability)	-0.25			0.25		%Span	1
Total Error Band	-1.0	-2.5		1.0	2.5	%Span	2
Compensated Temperature	-20	-30		+85	120	°C	
Operating Temperature	-40			+125		°C	3
Storage Temperature	-50			+125		°C	
Insulation Resistance (500Vdc)	100					MΩ	4
Short Circuit Protected			Yes				
Output Noise @ 1kHz			10			mV	
Long Term Stability	-0.25			0.25		%Span/Year	
Frequency Response @ -3dB			1			KHz	

Notes

1. Best fit straight line.
2. TEB includes all accuracy errors, thermal errors, span and zero tolerances over the compensated temperature range.
3. Temperature range for product with standard cable is -20°C to +105°C.
4. Between sensor body to any pins of connector.
5. The maximum pressure that can be applied without changing the transducer's performance or accuracy.
6. The maximum pressure that can be applied to a transducer without rupture of either the sensing element or transducer.
7. Refer to pressure port Listing notes for installation recommendations.
8. This product can be configured for custom OEM requirements. Contact Factory for different transfer function. See "Pressure Transfer Function" diagram.
9. Maximum temperature range for product with standard cable is -20°C to 105°C.
10. Do not apply torque to connector housing of transducer.
11. To ensure proper environmental sealing and electrical connections when using a mating connector, follow the connector manufacturer's installation guidelines.

ENVIRONMENTAL SPECIFICATIONS

Ambient Temperature: 25°C (unless otherwise specified)

PARAMETERS	MIN		TYP	MAX		UNITS	NOTES
	Short	Long		Short	Long		
Humidity (@40°C)				93		%RH	
Pressure Overload				2X		Rated	5
Pressure Burst				5X	3X	Rated	6
Pressure Cycle		10M				Cycles	
Media, Pressure Port	Short	Fluids compatible with 17-4PH Stainless Steel					
	Long	Fluids compatible with Brass					
Mechanical Vibration	Short	20g, 10 ~ 2000Hz MIL-STD-810C, Method 514.2, Curve L					
	Long	10g peak, 55~2000Hz MIL-STD-202G, Method 204D, Test Condition C					
Mechanical Shock	Short	Half-Sine, Peak: 50g, 11ms MIL-STD-202, Method 213B, Condition A					
	Long	Half-Sine, Peak: 50g, 11ms MIL-STD-202G, Method 213B, Condition A					
Package Protection				IP67 (IEC60529)			

Agency Approvals		
Short		Long
	RoHS: RoHS 2 (Directive 2011/65/EU)	
	UL 508 Certified: Industrial Control Equipment, CSA 22.2 No. 14-10	
	EMC Performance Criteria: Output Change < ±1.5% FSO	
	IEC61000-4-2 ESD: 8kV Contact / 15kV Air; Discharge Rate > 10s	
	IEC61000-4-3 EM Field: 100V/m, 1kHz 80% Modulation, 80 ~ 1000MHz	
	IEC61000-4-4 Electrical Fast Transient: Level 2, 1KV each line, Capacitance coupling	
	IEC61000-4-5 Surge: Level 2, 42Ω Impedance, Figure 11 (L-L 500V, L-E 1KV)	
	IEC61000-4-6 Conducted RF: Level 2, 3V/130dB, 150KHz ~ 80MHz, 2s Dwell, Clamp Injection	
	IEC61000-4-9 Pulse Magnetic Field: Level 3, 100A/m, 10 Second pulse interval	
	IEC55022 Emission: Class B, 30dB @ 30-230MHz, 37dB @ 230-1000MHz	

Pressure Port Options	Dim A	Tightening Torque (Nm)
2 = G1/4, BS5380, Male	.43 [11.0]	30~35
4 = 7-16-20 UNF, SAE J1926-2, Male, w/ O-Ring	.36 [9.1]	18~20
5 = 1/4-18 NPT Male	.56 [14.2]	2~3 T.F.F.T.
6 = 1/8-27 NPT Male	.38 [9.7]	2~3 T.F.F.T.
E = R1/4-19, Male	.56 [14.2]	2~3 T.F.F.T.
F = G1/4-19, BS5380, Female	.64 [16.3]	30~35
P = 7/16-20UNF Female w/ Integral Valve Depressor; 1/4 Flare Gasket SAE J513C, Copper	.64 [16.3]	15~16
Q = M10 x 1.0, ISO 6149-2, Male	.37 [9.5]	15~16
S = M12 x 1.5, ISO 6149-2, Male	.43 [11.0]	28~30
G = M14 x 1.5, ISO 6149-2, Male	.43 [11.0]	30~35
U = G1/4, DIN 3852-E, Male	.47 [12.0]	30~35

Notes: Installation

*T.F.F.T.: Turns From Finger Tight

Transducers can be installed by either spanner or deep socket. Torque values provided are for reference: actual torque depends upon mating port material, surface finish, lubrication and sealing mechanism. Transducers calibration and/or zero may shift if part is over-torqued during installation. Check for a zero shift after installing.

Connector Information

Connector	Connector, Pin Plating	Connector, Mating
Packard Metri-Pack 150 Series	<i>powerandsignal.com</i> 0.003 – 0.005 mm Sn	Housing P/N: 12065287 Terminals P/N: 12103881
Sumitomo HV040 Series	<i>sumitomokenki.com</i> 0.003 mm Sn over 0.0005 – 0.001 mm Cu	Housing P/N: 6189-6907 Terminals P/N: 8100-3067/8
AMP Econoseal-J Mark II 070 Series	<i>te.com</i> 0.0004 mm Au over 0.0013 mm Ni	Housing P/N: 174357 Terminals P/N: 171630

DIMENSIONS

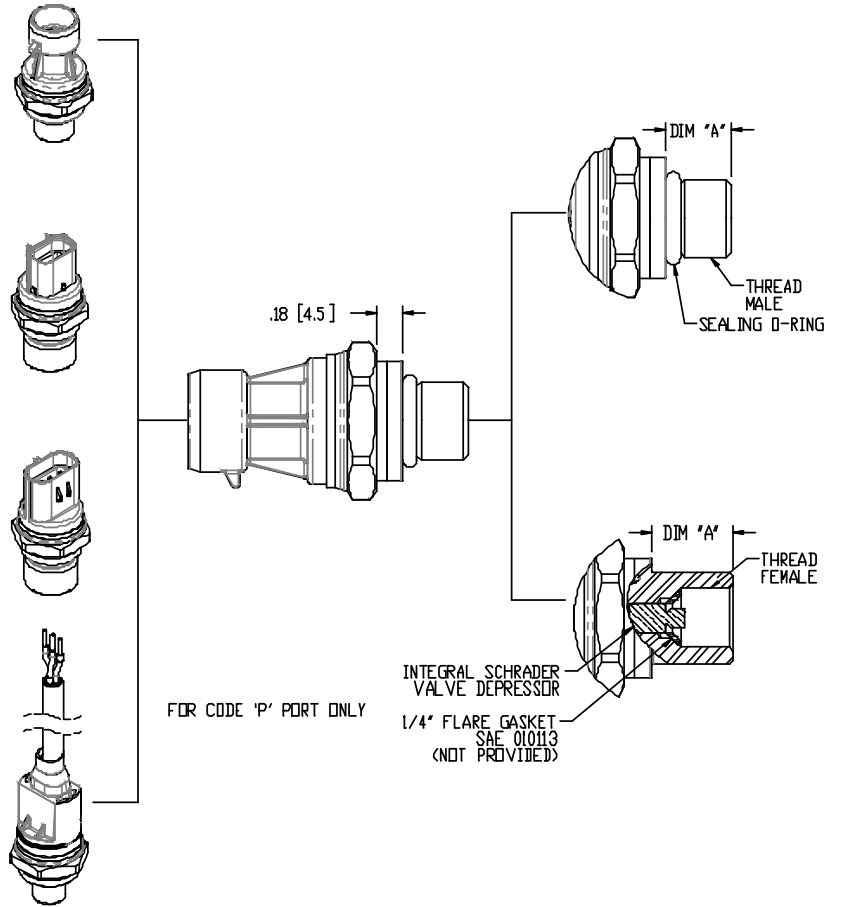
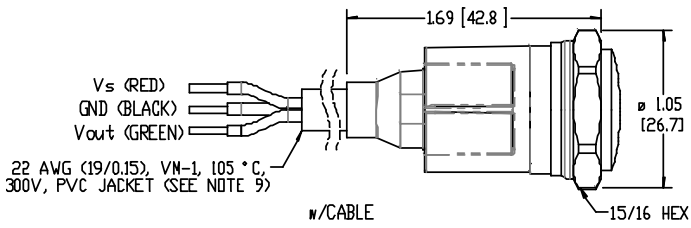
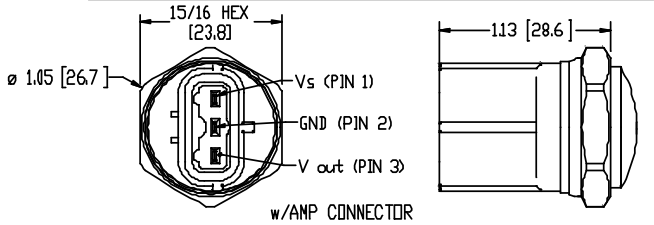
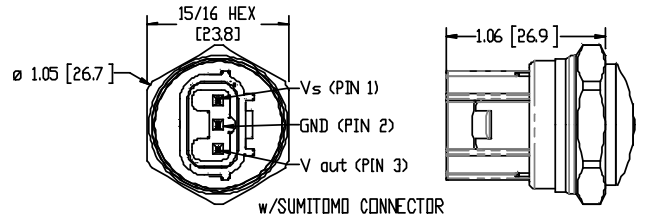
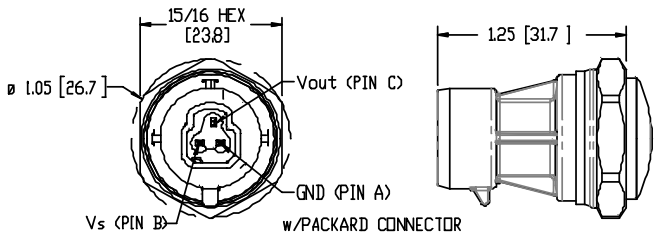

Long Tube Option.

DIMENSIONS ARE IN mm [INCHES]

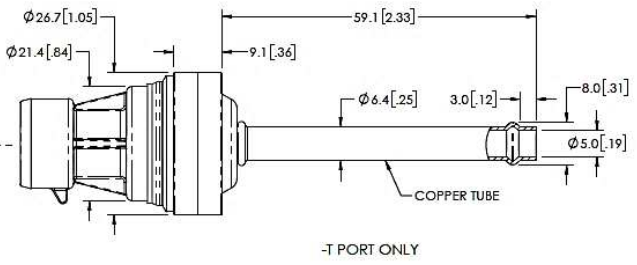
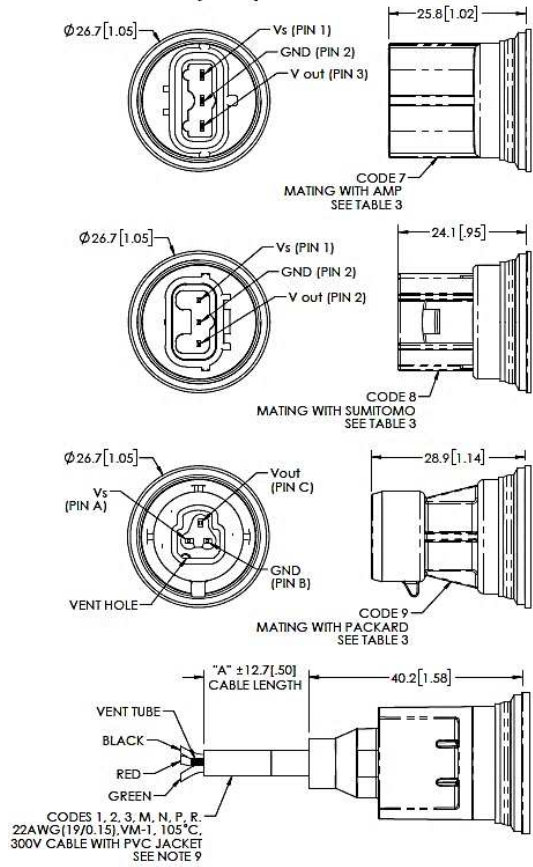

CABLE WIRE # DESIGNATION	
WIRE COLOR	FUNCTION
RED	Vs
BLACK	GND
GREEN	Vout

CHARTS

Pressure Transfer Function

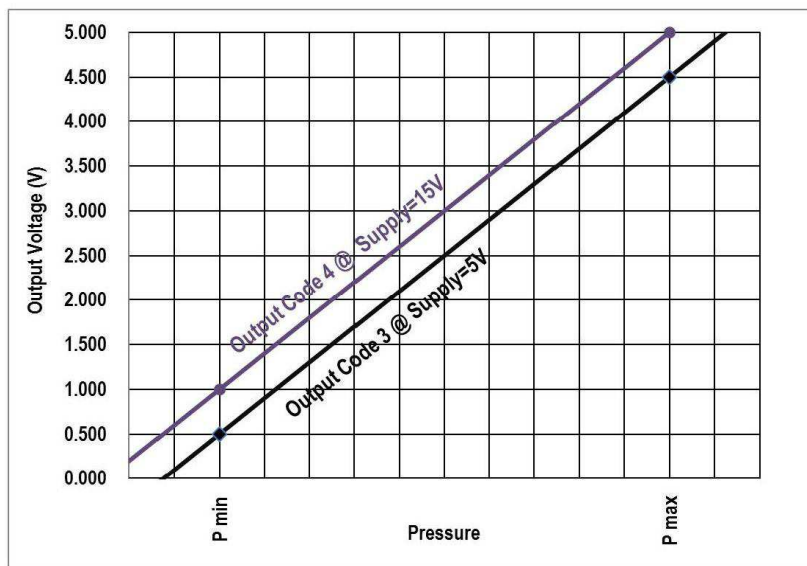

Output Type vs. Supply

Output Type (Code)	3	4
Supply Voltage	4.75 ~ 5.25V*	8 ~ 32V
Supply Current	4.0 ~ 10.0mA	
Output Voltage	0.5 ~ 4.5V*	1.0 ~ 5.0V
Reverse Voltage	16V	
Overvoltage Protection	16V	32V

* Output ratiometric to supply voltage

Pressure Range	
psi	bar
150P	010B
200P	014B
300P	020B
500P	035B
01KP	070B
1K5P	100B
03KP	200B
05KP	350B
7K5P	500B
10KP	700B

Note: Short Tube Options

Pressure Range	
psi	bar
150P	010B
300P	020B
450P	030B
500P	035B
750P	050B

Note: Long Tube Range Options

Connection Type
1 = Cable 2 ft
2 = Cable 4 ft
3 = Cable 10 ft
7 = AMP070 Connector
8 = Sumitomo HV040 Connector
9 = Packard Connector
M = Cable 1 m
N = Cable 2 m
P = Cable 5 m
R = Cable 10 m

ORDERING INFORMATION

M71 Model Name	3	P	-	150P	G	-	P	B	0000
Output 3=0.5-4.5V Ratiometric 4=1.0-5.0V									
Connections See Connections Table									
Pressure Range See to Pressure Range Table*									
Pressure Type G = Gage									
Pressure Port									
2=G1/4,BS5380, Male				4=7/16-20UNF, SAE J1926-2, Male, with O-Ring					
5=1/4-18 NPT Male	6=1/8-27 NPT Male			E=R1/4-19, Male					
F=G1/4-19, BS5380, Female				Q=M10 x 1.0, ISO 6149-2					
P=7/16-20UNF Female with Integral Valve Depressor. 1/4 Flare Gasket SAE J513C, Copper									
S=M12x1.5, ISO 6149-2, Male				T=1/4"OD Copper Tube					
G=M14x1.5, ISO 6149-2 Male				U=G1/4, DIN 3852-E male					
Port Material									
0=17-4PH Stainless Steel				B=Copper, C12200					

Those marked in blue MUST be paired.

*If ordering with BLUE options, refer to Tables for Long Tube Version.

NORTH AMERICA

Measurement Specialties, Inc.,
a TE Connectivity Company
Phone: 800-522-6752
Email: customercare.frm@te.com

EUROPE

Measurement Specialties (Europe), Ltd.,
a TE Connectivity Company
Phone: 800-440-5100
Email: customercare.lcsb@te.com

ASIA

Measurement Specialties (China), Ltd.,
a TE Connectivity Company
Phone: 0400-820-6015
Email: customercare.shzn@te.com

TE.com/sensorsolutions

Measurement Specialties, Inc., a TE Connectivity company.

Measurement Specialties, TE Connectivity, TE Connectivity (logo) and EVERY CONNECTION COUNTS are trademarks. All other logos, products and/or company names referred to herein might be trademarks of their respective owners.

The information given herein, including drawings, illustrations and schematics which are intended for illustration purposes only, is believed to be reliable. However, TE Connectivity makes no warranties as to its accuracy or completeness and disclaims any liability in connection with its use. TE Connectivity's obligations shall only be as set forth in TE Connectivity's Standard Terms and Conditions of Sale for this product and in no case will TE Connectivity be liable for any incidental, indirect or consequential damages arising out of the sale, resale, use or misuse of the product. Users of TE Connectivity products should make their own evaluation to determine the suitability of each such product for the specific application.

© 2015 TE Connectivity Ltd. family of companies All Rights Reserved.