

DETAIL SPECIFICATION SHEET

DUMMY LOADS, ELECTRICAL, COAXIAL,
TYPE I (SMA), LOW POWER

This specification is approved for use by all Departments and Agencies of the Department of Defense.

The requirements for acquiring the product described herein shall consist of this specification sheet and MIL-DTL-39030.

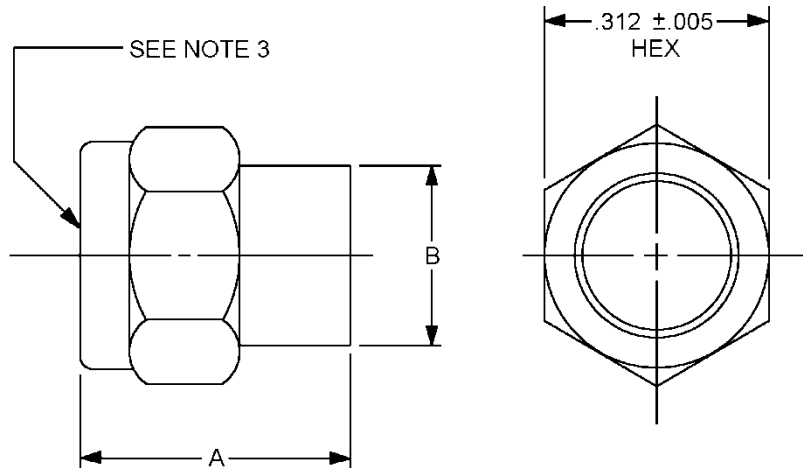

Inches	mm
.005	0.13
.27	6.9
.28	7.1
.312	7.92
.43	10.9
.56	14.2
.73	18.5

Dash number	A max	B max
-01, -16	.73	.28
-02, -17	.73	.28
-11, -22	.43	.27
-15, -26	.56	.28

NOTES:

1. Dimensions are in inches.
2. Metric equivalents are given for information only.
3. Series SMA pin contact interface in accordance with MIL-STD-348.
4. Part or Identifying Number (PIN).

FIGURE 1. Dimensions and configuration, PINs M39030/3-01, -02, -11, -15, -16, -17, -22, and -26 (both N and S).

MIL-DTL-39030/3E

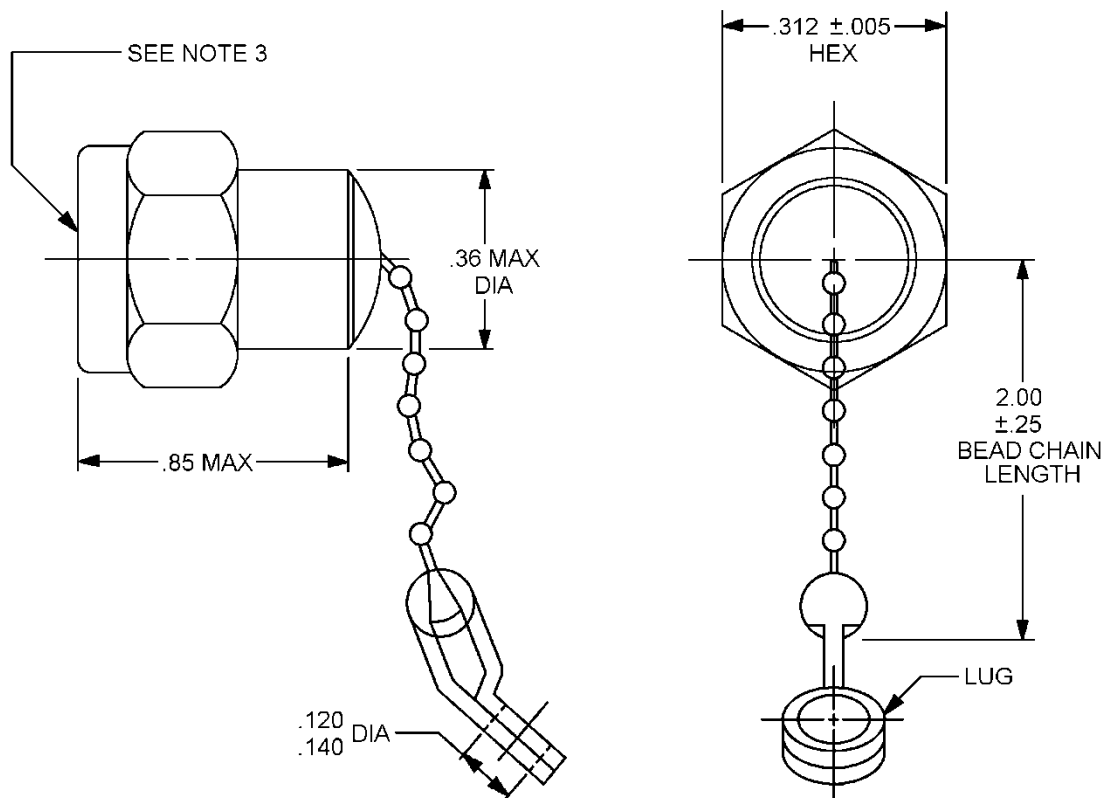

Inches	mm
.005	0.13
.120	3.05
.140	3.56
.25	6.4
.312	7.92
.36	9.1
.85	21.6
2.00	50.8

NOTES:

1. Dimensions are in inches.
2. Metric equivalents are given for information only.
3. Series SMA pin contact interface in accordance with MIL-STD-348.

FIGURE 2. Dimensions and configuration, PINs M39030/3-03, -04, -18 and -19 (both N and S).

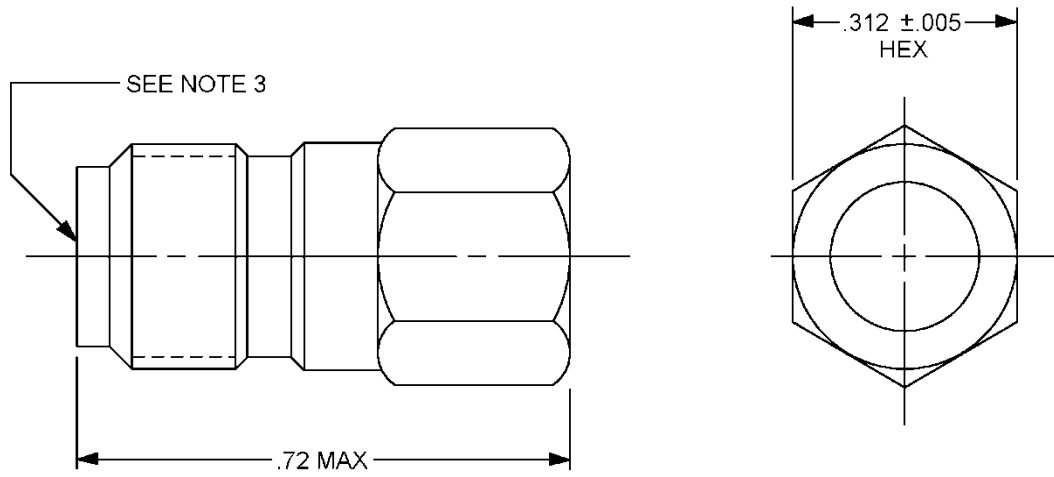

Inches	mm
.005	0.13
.312	7.92
.72	18.3

NOTES:

1. Dimensions are in inches.
2. Metric equivalents are given for information only.
3. Series SMA socket contact interface in accordance with MIL-STD-348.

FIGURE 3. Dimensions and configuration, PINs M39030/3-05 and -06 (both N and S).

MIL-DTL-39030/3E

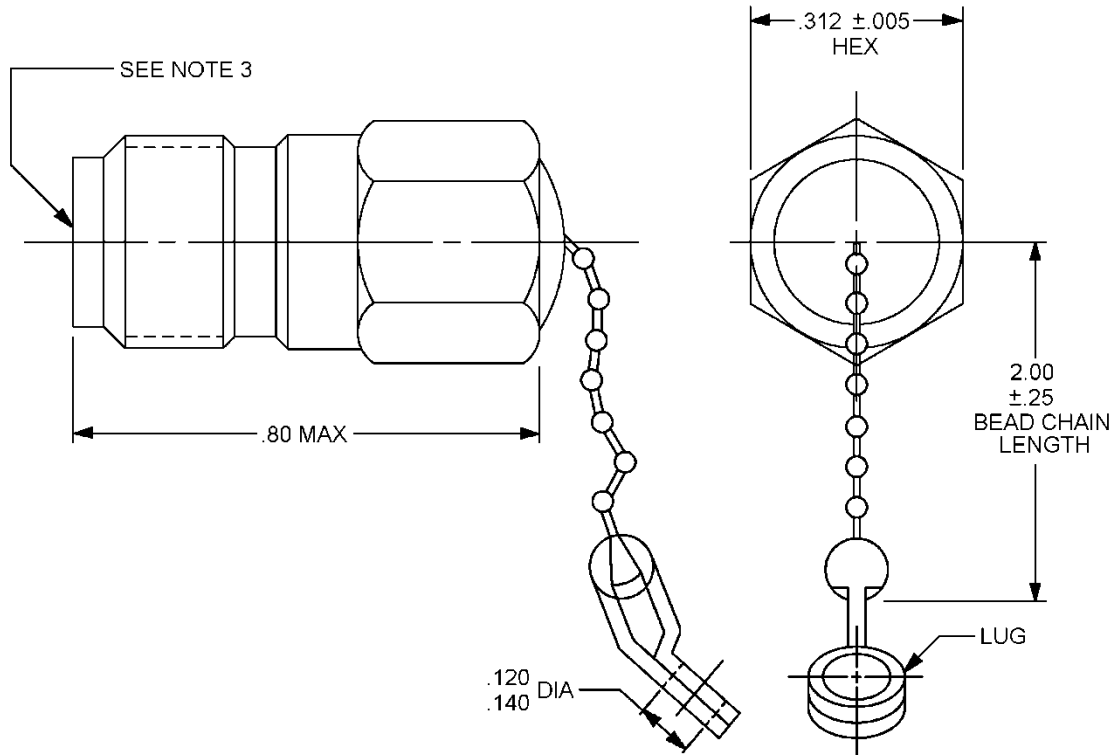

Inches	mm
.005	0.13
.120	3.05
.140	3.56
.25	6.4
.312	7.92
.80	20.3
2.00	50.8

NOTES:

1. Dimensions are in inches.
2. Metric equivalents are given for information only.
3. Series SMA socket contact interface in accordance with MIL-STD-348.

FIGURE 4. Dimensions and configuration, PINs M39030/3-07 and -08 (both N and S).

MIL-DTL-39030/3E

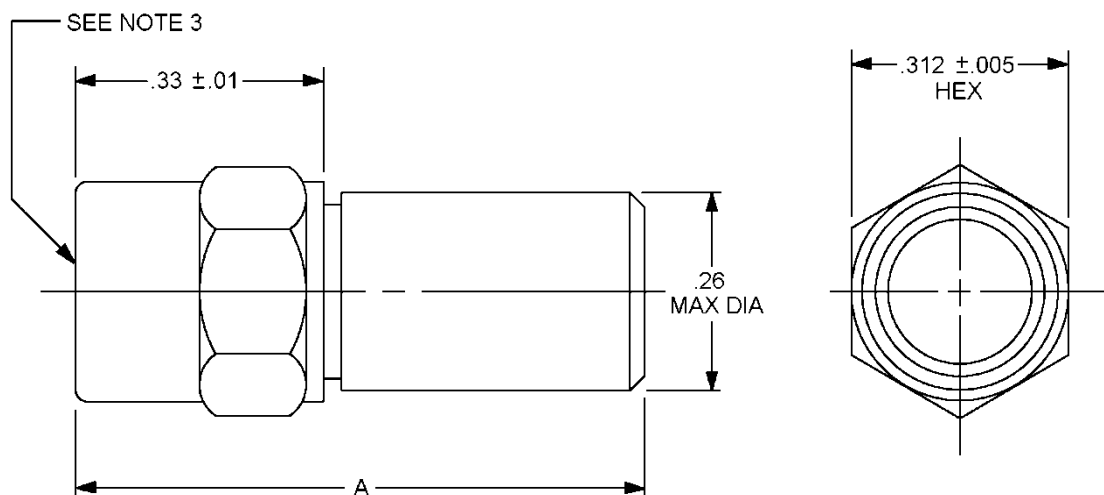

Inches	mm
.005	0.13
.01	0.3
.26	6.6
.312	7.92
.33	8.4
.55	14.0
.84	21.3

Dash number	A max
-09, -20	.84
-10, -21	.55
-12, -23	.55
-14, -25	.55

NOTES:

1. Dimensions are in inches.
2. Metric equivalents are given for information only.
3. Series SMA pin contact interface in accordance with MIL-STD-348.

FIGURE 5. Dimensions and configuration, PINs M39030/3-09, -10, -12, -14, -20, -21, -23, and -25 (both N and S).

MIL-DTL-39030/3E

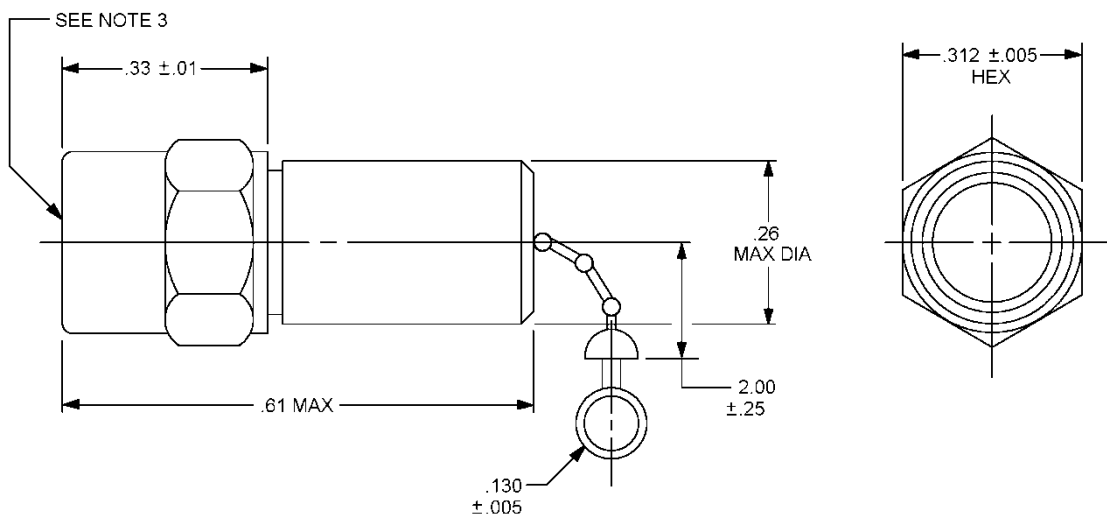

Inches	mm
.005	0.13
.01	0.3
.130	3.30
.25	6.4
.26	6.6
.312	7.92
.33	8.4
.61	15.5
2.00	50.8

NOTES:

1. Dimensions are in inches.
2. Metric equivalents are given for information only.
3. Series SMA pin contact interface in accordance with MIL-STD-348.

FIGURE 6. Dimensions and configuration, PINs M39030/3-13 and -24 (both N and S).

MIL-DTL-39030/3E

TABLE I. Dash numbers and characteristics.

Dash number both N and S	Operating frequency (GHz)	VSWR (max)	Power handling capability (max)		Nominal characteristic impedance (ohms)	Weight (max) (oz)	Finish	Figure numbers
			Average (watts)	Peak ^{1/} (watts)				
01, 16 <u>6/</u>	DC to 18	(1.05 +.010f):1 <u>2/</u>	.5 <u>3/</u>	50 <u>3/</u>	50	0.25	<u>4/</u>	1
02, 17 <u>6/</u>	DC to 18	(1.05 +.010f):1 <u>2/</u>	.5 <u>3/</u>	50 <u>3/</u>	50	0.25	<u>5/</u>	1
03, 18 <u>6/</u>	DC to 18	(1.05 +.010f):1 <u>2/</u>	.5 <u>3/</u>	50 <u>3/</u>	50	0.25	<u>4/</u>	2
04, 19 <u>6/</u>	DC to 18	(1.05 +.010f):1 <u>2/</u>	.5 <u>3/</u>	50 <u>3/</u>	50	0.25	<u>5/</u>	2
05	DC to 18	(1.05 +.010f):1 <u>2/</u>	.5 <u>3/</u>	50 <u>3/</u>	50	0.25	<u>4/</u>	3
06	DC to 18	(1.05 +.010f):1 <u>2/</u>	.5 <u>3/</u>	50 <u>3/</u>	50	0.25	<u>5/</u>	3
07	DC to 18	(1.05 +.010f):1 <u>2/</u>	.5 <u>3/</u>	50 <u>3/</u>	50	0.25	<u>4/</u>	4
08	DC to 18	(1.05 +.010f):1 <u>2/</u>	.5 <u>3/</u>	50 <u>3/</u>	50	0.25	<u>5/</u>	4
09, 20 <u>6/</u>	DC to 10	1.10:1	1.0	100	50	0.25	<u>4/</u>	5
10, 21 <u>6/</u>	DC to 10	2.10:1	2.0	200	95	0.25	<u>4/</u>	5
11, 22 <u>6/</u>	DC to 18	1.15:1	1.0	100	50	0.25	<u>4/</u>	1
12, 23 <u>6/</u>	2 to 19	1.30:1	1.0	100	50	0.25	<u>4/</u>	5
13, 24 <u>6/</u>	2 to 19	1.30:1	.5	50	50	0.25	<u>4/</u>	6
14, 25 <u>6/</u>	2 to 19	1.30:1	1.0	100	75	0.40	<u>4/</u>	5
15, 26 <u>6/</u>	4.4 to 5.0	(1.025 +.005f):1 <u>2/</u>	.5	50	50	0.25	<u>4/</u>	1

^{1/} Peak power is specified with a 1 percent duty cycle.

^{2/} "f" is the frequency in GHz.

^{3/} Power input is derated linearly from 100 percent at +25°C to 25 percent at specified maximum ambient operating temperature.

^{4/} Gold plated in accordance with ASTM B488, type II, grade C, class 1.27, over copper flash.

^{5/} Passivated in accordance with ASTM A967 or SAE-AMS2700.

^{6/} Furnished with safety wire holes (for high vibration areas). Three holes .016-inch (0.41 mm) minimum diameter, equally spaced, are required for safety wiring after mating. Location on coupling nut is optional.

REQUIREMENTS:

Dimensions and configurations: See figures 1 thru 6.

Electrical characteristics: See table I.

Materials:

Body and connector: Corrosion-resistant steel in accordance with SAE-AMS-QQ-S-763 or ASTM A484/A484M and ASTM A582/A852M.

Finish: See table I.

Contact pin and contact socket: Beryllium copper in accordance with ASTM B194, ASTM B196/B196M, or ASTM B197/B197M.

Finish: The male pin shall be plated to a minimum gold thickness of 50 micro inches (1.27 μ m) in accordance with ASTM B488, type II, code C, class 1.27, over 50 micro inches (1.27 μ m) minimum of nickel in accordance with SAE-AMS-QQ-N-290, class 1, measured anywhere along the mating surface, for all series. The socket contact shall be plated to a minimum of 50 micro inches (1.27 μ m) of gold in accordance with ASTM B488, type II, code C, class 1.27, over 50 micro inches (1.27 μ m) minimum of nickel in accordance with SAE-AMS-QQ-N-290, class 1, including the I.D., measured at a depth of .040 inch minimum.

The plating on non-significant surfaces in the I.D. shall be of sufficient thickness to ensure plating continuity and uniform utility and protection. This plating may consist of an underplate only. A silver underplate shall not be permitted.

Bead chain and lug: Corrosion-resistant steel or plastic.

Weight: See table I.

Ambient temperature range:

Operating:

Dash numbers 01 thru 08, 11, 15, 16 thru 19, 22 and 26: -55°C to +125°C.

Dash numbers 09, 10, 12, 13, 14, 20, 21, 23, 24 and 25: -65°C to +125°C.

Nonoperating (storage): -65°C to +165°C.

Connector tests: The following tests shall, be performed after visual and mechanical examination in the qualification inspection.

Force to engage and disengage: Torque 2 inch-pounds, maximum.

Coupling proof torque (for plug male type only): 15 inch-pounds, minimum.

Threaded coupling connector: For each test of threaded coupling connector where the test is performed on mated pairs, the pairs shall be torque to 7 to 10 inch-pounds.

Connector durability: 500 cycles at 12 cycles per minute, maximum. After this test, the connector shall meet the engage and disengage requirement.

Vibration: Method 204 of MIL-STD-202, test condition D.

Shock: Method 213 of MIL-STD-202, test condition I.

Barometric pressure: Method 105 of MIL-STD-202, test condition C.

MIL-DTL-39030/3E

PIN: M39030/3-(dash number from table I) (S = screened or N = not screened).

Marginal notations are not used in this revision to identify changes with respect to the previous issue due to the extent of the changes.

In addition to MIL-DTL-39030, this specification sheet references the following documents:

ASTM A484/A484M	MIL-STD-202
ASTM A582/A582M	MIL-STD-348
ASTM A967	SAE-AMS-QQ-N-290
ASTM B194	SAE-AMS2700
ASTM B196/B196M	SAE-AMS-QQ-S-763
ASTM B197/B197M	
ASTM B488	

CONCLUDING MATERIAL

Custodians:
Army - CR
Navy - EC
Air Force - 85
DLA - CC

Preparing activity:
DLA - CC

(Project 5985-2013-024)

Review activities:
Army - AV, MI
Navy - AS, OS, SH
Air Force - 19

NOTE: The activities listed above were interested in this document as of the date of this document. Since organizations and responsibilities can change, you should verify the currency of the information above using the ASSIST Online database at <https://assist.dla.mil>.