

500-1500W Single Output Industrial Power Supplies

Features

- ◆ 5 Year Warranty
- ◆ -40°C to +71°C Operation
- ◆ MIL-STD-810E Vibration / Shock
- ◆ Input transient protected
- ◆ UL508, SEMIF47
- ◆ Rugged mechanical design with coating on pcbs
- ◆ Superior thermal design
- ◆ Wide range adjustment of output



Key Market Segments & Applications



Specifications		LZSA-500	LZSA-1000	LZSA-1500
Input Voltage (47-440Hz) (*)	-	85 - 265VAC (LZSA1500 - see output derating graphs on page 2), 100-380VDC (1)		
Inrush Current (110 / 220VAC)	A	25 / 45A	30 / 40A	
Power Factor	-	EN61000-3-2 Class A		
Efficiency (typical)	%	84%		
Ripple & Noise (Pk-Pk)(max)	-	75mV	75mV	24V: 75mV; 48V: 150mV
Line Regulation	%	0.1%		
Load Regulation	%	0.1%		
Transient Response	-	±1% deviation, recovering to ±0.2% in <1.25ms (25% load change)		
Overcurrent Protection	-	110 - 130%		
Overvoltage Protection	V	User adjustable from front panel		
Thermal Protection	-	Internal thermostat. Recycle AC to reset		
Hold Up Time at 110VAC	ms	20ms Hold Up, 20ms Ride Through		
Remote Sense	-	Compensates for a total of 1V cable drop		
Remote Adjust	-	Using front panel potentiometer, Resistance (1k/V), or Voltage (1V/V)		
Remote On / Off	-	TTL compatible, active high		
Signals	-	Optocoupled transistor for AC Fail, DC Good, Inverter OK. 200kHz sync signal (Ref-sense)		
Indicators	-	Green LED indicates output good, red LED indicates overvoltage or over temperature		
Parallel Connection	-	Single wire current share		
Operating Temperature	°C	-40° to +71°C, derate linearly to 60% load from 60°C~71°C (20 min warm up period needed for <-30°C)		
Storage Temperature	°C	-40° to +85°C		
Temperature Coefficient	-	0.01%/°C		
Humidity (non condensing)	%RH	10 - 90%RH		
Cooling	-	Internal fan		
Withstand Voltage	-	Input - Ground 2,121VDC, Input - Output 4,242VDC, Output - Ground 500VDC		
Vibration	-	MIL-STD-810E, Method 514.4, Category 1, 9		
Shock	-	MIL-STD-810E, Method 516.4 Proc. I, II, IV, VI		
Safety Agency Certifications	-	IEC/UL/CSA/EN62368-1, 60950-1, UL508, CE Mark. ((LVD, EMC and RoHS), SEMIF47(>100VAC)		
Leakage current	uA	<500uA at 265VAC, 60Hz		
Emissions	-	EN55022/EN55011 Class B, EN61000-3-3, MIL STD 461/462D CE102		
Immunity	-	EN61000-4-2, -3, -4, -5, -6, -8, -11. IEEE C62.41 (6kV/30 Ohm, Criteria A)		
Altitude	m	3,000m operating, 12,000m non operating		
Weight	lbs	6.6 lbs or 2.95 kg	8.1 lbs or 3.7kg	
Size (LxWxH)(w/o bus bars)	mm	260 x 108 x 121mm	267 x 143 x 121mm	
Size (LxWxH)	in	10.25 x 4.25 x 4.75"	267 x 143 x 4.75"	
Warranty	yrs	Five Years		

(1) Startup > 110VDC

Notes: (Consult Installation Manual for detailed specifications, test methods and application notes) (*) Reduced power factor above 63Hz

Derating Charts

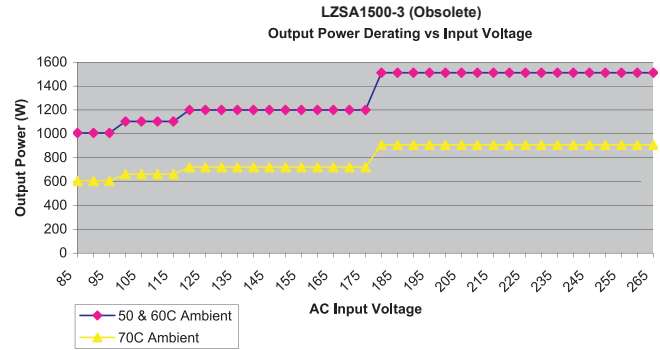
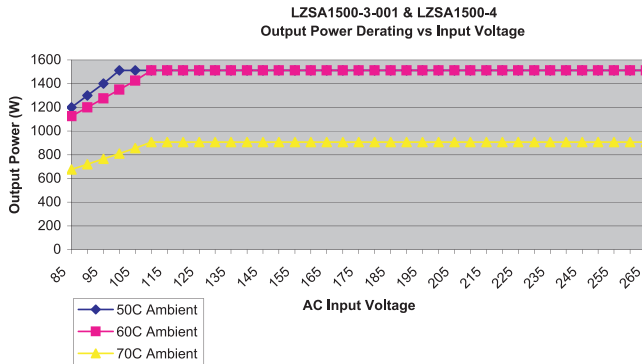

Outline Drawing (LZSA1500)

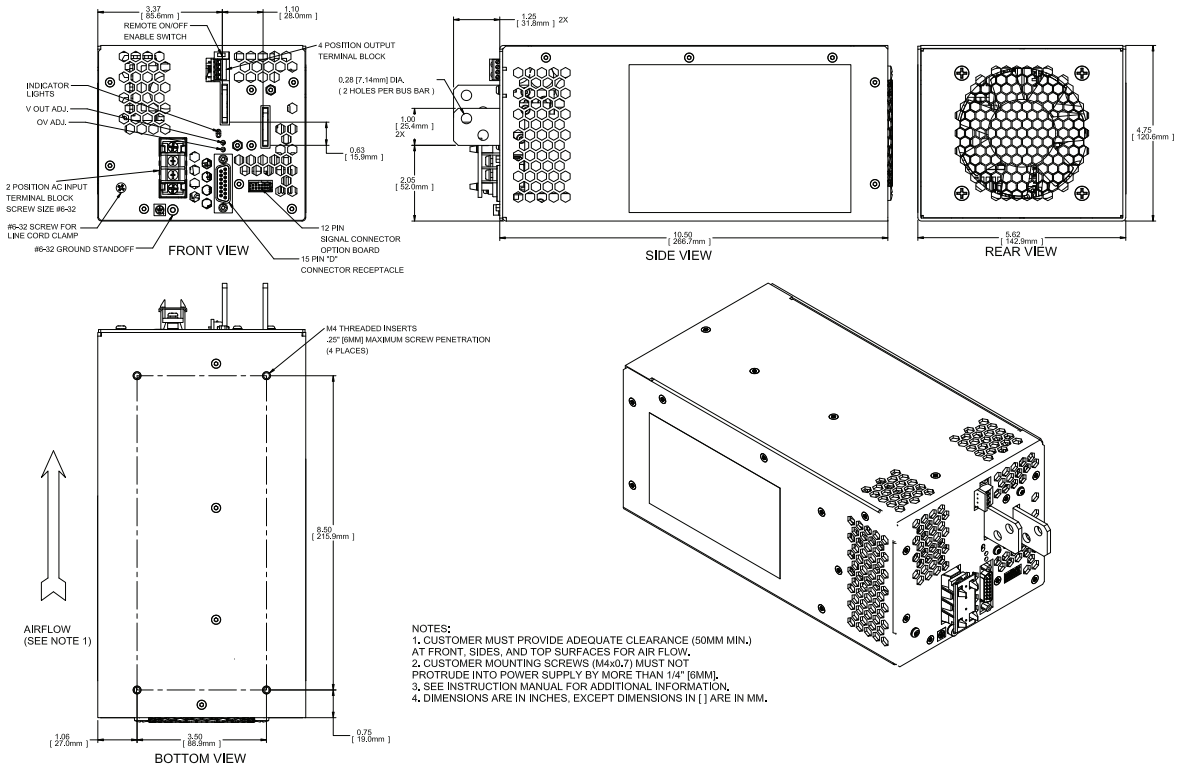

Model Selector

Model	Nominal Voltage (V)	Adjustment Range (V)	Maximum Current (A)	Maximum Power (W)
LZSA-1000-2	12	10 - 15.75	84	1008
LZSA-500-3	24	18 - 29.4	21	504
LZSA-1000-3	24	18 - 29.4	42	1008
LZSA-1500-3	24	18 - 29.4	63	1512
LZSA-1500-3-001	24	18 - 29.4	63	1512
LZSA-1500-4	48	36 - 56	31.5	1512

For Additional Information, please visit
<https://product.tdk.com/en/power/>



*Model highlighted in blue is obsolete. Please use LZSA1500-3-001.