

## Light is OSRAM

# OSRAM

Opto Semiconductors

Our Brand

LED ENGIN



LuxiGen™ Multi-Color Emitter Series

LZ7 Plus Flat Lens Emitter

RGB – PC Amber – Cyan – PC Lime

# LZ7-04M2PD

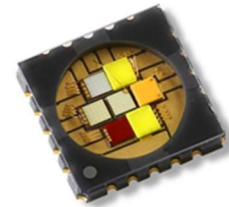

### Key Features

- 6-color surface mount ceramic LED package with integrated flat glass lens
- 60W power in a small 7.0mm x 7.0mm emitter footprint
- Red, Green, Blue, PC Amber, Cyan and PC Lime enables richer and wider color combination for more sophisticated color mixing
- Compact 3.4mm x 3.4mm Light Emitting Surface (LES) and low profile package maximize coupling efficiency into secondary optics
- Thermal resistance of 0.8 °C/W
- Electrically neutral thermal path
- JEDEC Level 1 for Moisture Sensitivity Level
- Lead (Pb) free and RoHS compliant

### Typical Applications

- Stage and Studio Lighting
- Effect Lighting
- Accent Lighting
- Display Lighting
- Architectural Lighting

### Note

This product emits Blue light, which can be hazardous depending on total system configuration (including, but not limited to optics, drive current and temperature). Do not stare directly into the beam and observe safety precaution given in IEC 62471 when operating this product.

## LZ7-04M2PD

### Part number options

#### Base part number

Part number	Description
LZ7-04M2PD-0000	LZ7 Plus RGB-PC Amber-Cyan-PC Lime flat lens emitter
LZ7-A4M2PD-0000 <sup>[1]</sup>	LZ7 Plus RGB-PC Amber-Cyan-PC Lime flat lens emitter on 7 channel MCPCB

Note:

1. Emitter on MCPCB option is only offered through catalog distributors.

#### Bin kit option codes

##### M2, Red-Green-Blue-PC Amber-Cyan-PC Lime

Kit number suffix	Min flux Bin	Color Bin Ranges	Description
0000	27R	A-B	Red, full distribution flux; full distribution wavelength
	31G	A-B	Green, full distribution flux; full distribution wavelength
	9B	A	Blue, full distribution flux; full distribution wavelength
	17A	PA2	PC Amber, full distribution flux; full distribution wavelength
	3C	A	Cyan, full distribution flux; full distribution wavelength
	2L	L	PC Lime, full distribution flux; full distribution wavelength

## LZ7-04M2PD

### Flux Bins

Table 1:

Bin Code	Minimum Flux @ I <sub>F</sub> = 1000mA <sup>[1]</sup>						Maximum Flux @ I <sub>F</sub> = 1000mA <sup>[1]</sup>					
	Im	Im	W	Im	Im	Im	Im	Im	W	Im	Im	Im
	1x Red	1x Green	1x Blue	1x PC Amber	1x Cyan	2x PC Lime	1x Red	1x Green	1x Blue	1x PC Amber	1x Cyan	2x PC Lime
27R	85						130					
31G		160						210				
32G		210						280				
9B			1.0						1.5			
17A				90						175		
3C					85						156	
2L						495						700
3L						700						1000

Notes for Table 1:

- Flux performance is measured at 10ms pulse, T<sub>C</sub> = 25°C. LED Engin maintains a tolerance of ±10% on flux measurements.

### Wavelength Bins

Table 2:

Bin Code	Minimum Dominant Wavelength (λ <sub>D</sub> ) @ I <sub>F</sub> = 1000mA <sup>[1]</sup> (nm)				Maximum Dominant Wavelength (λ <sub>D</sub> ) @ I <sub>F</sub> = 1000mA <sup>[1]</sup> (nm)			
	1x Red	1x Green	1x Blue	1x Cyan	1x Red	1x Green	1x Blue	1x Cyan
	A	620				624		
B	624				628			
A		519				522		
B		522				525		
A			449				453	
A				495				502

Notes for Table 2:

- Wavelength is measured at 10ms pulse, T<sub>C</sub> = 25°C. LED Engin maintains a tolerance of ± 1.0nm on dominant wavelength measurements.

Forward Voltage Bin

Table 3:

Bin Code	Minimum Forward Voltage (V <sub>F</sub> ) @ I <sub>F</sub> = 1000mA <sup>[1]</sup> (V)						Maximum Forward Voltage (V <sub>F</sub> ) @ I <sub>F</sub> = 1000mA <sup>[1]</sup> (V)					
	1x Red	1x Green	1x Blue	1x PC Amber	1x Cyan	2x PC Lime	1x Red	1x Green	1x Blue	1x PC Amber	1x Cyan	2x PC Lime
0	1.8	3.0	2.7	2.8	2.9	5.4	2.8	4.1	3.4	3.8	4.0	6.8

Notes for Table 3:

- Forward voltage is measured at 10ms pulse, T<sub>C</sub> = 25°C. LED Engin maintains a tolerance of ± 0.04V/ die for forward voltage measurements.

PC Amber Chromaticity Group

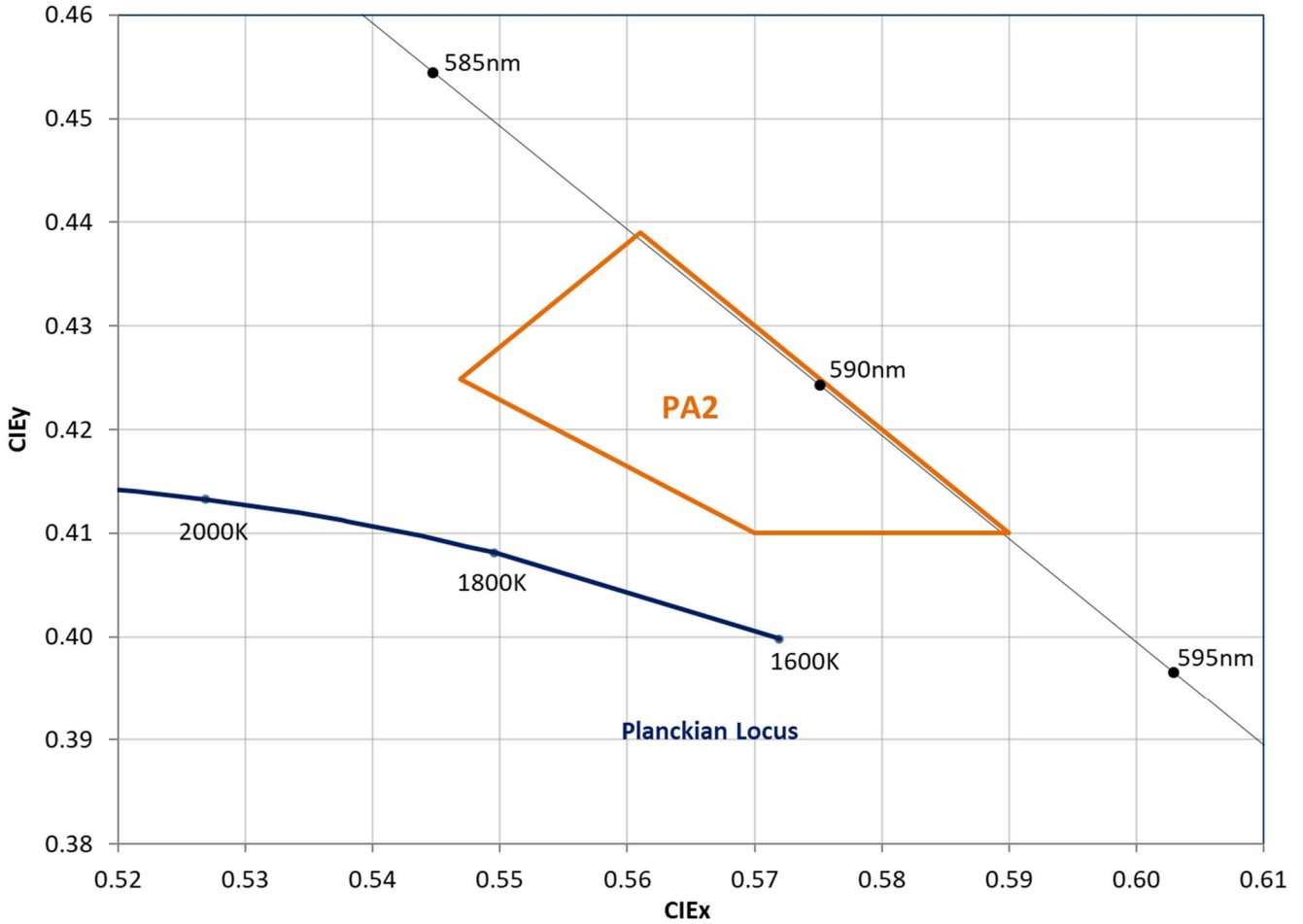

Standard Chromaticity Groups plotted on excerpt from the CIE 1931 (2°) x-y Chromaticity Diagram

Coordinates are listed below

PC Amber Bin Coordinates

Bin Code	CIE <sub>x</sub>	CIE <sub>y</sub>
PA2	0.5469	0.4249
	0.5700	0.4100
	0.5900	0.4100
	0.5610	0.4390
	0.5469	0.4249

**LZ7-04M2PD**

**PC Lime Chromaticity Group**

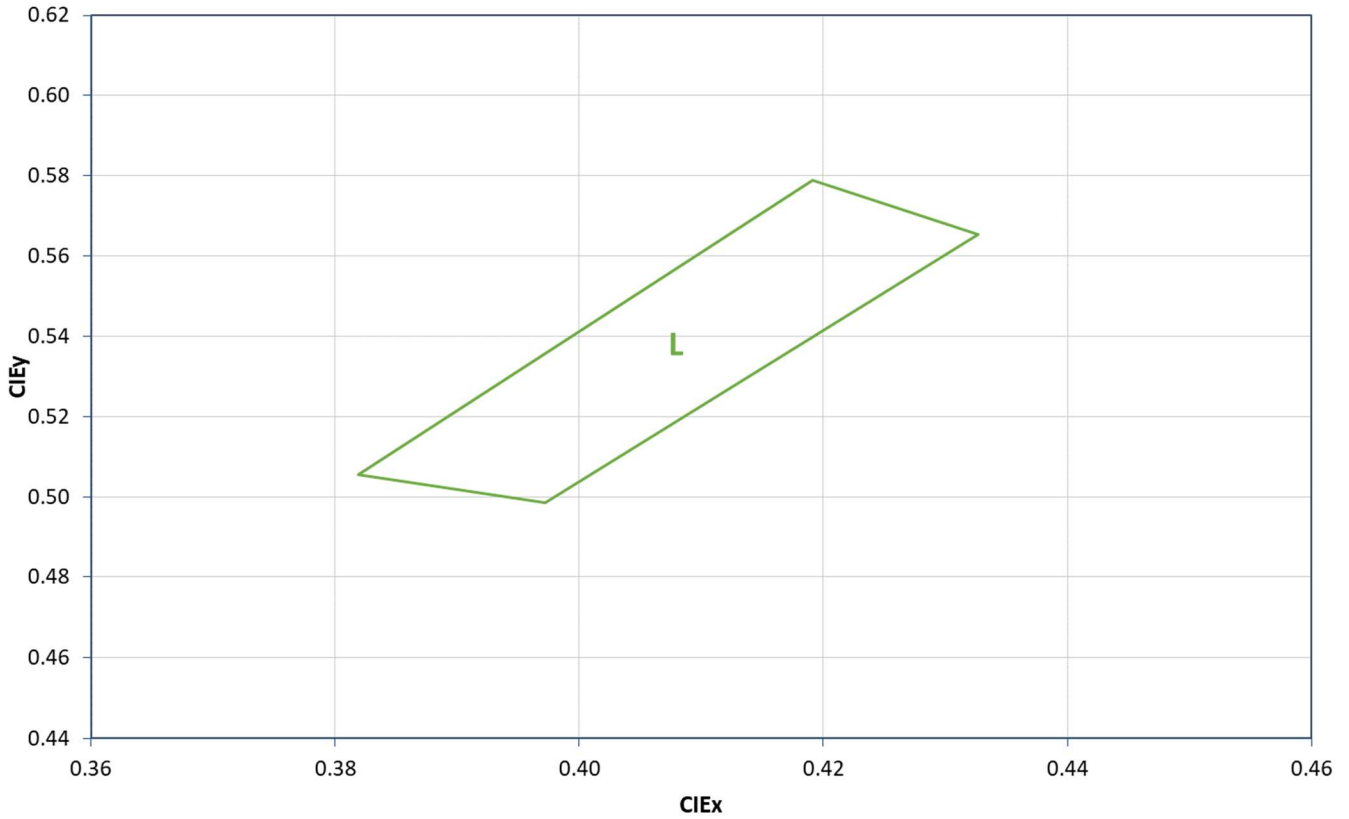

Standard Chromaticity Groups plotted on excerpt from the CIE 1931 (2°) x-y Chromaticity Diagram

Coordinates are listed below

**PC Lime Bin Coordinates**

Bin Code	CIE x	CIE y
L	0.3819	0.5055
	0.4191	0.5790
	0.4327	0.5655
	0.3972	0.4986
	0.3819	0.5055

Note:

- 1. For binning purposes, both PC Lime dies are connected in series.

## Absolute Maximum Ratings

Table 4:

Parameter	Symbol	Value	Unit
DC Forward Current / Peak Pulsed Forward Current <sup>[1]</sup> (per die)			
Red		40 – 2500 / 2500	
Green, Blue	I <sub>F</sub>	40 – 3000 / 3000	mA
PC Amber		10 – 1500 / 2000	
Cyan		30 – 1000 / 1000	
PC Lime		40 – 2500 / 3000	
Electrical Input Power <sup>[2]</sup>	P <sub>el</sub>	60	W
Reverse Voltage	V <sub>R</sub>	See Note 3	V
Storage Temperature	T <sub>std</sub>	-40 ~ +125	°C
Junction Temperature	T <sub>J</sub>	125	°C
Case Temperature (at P <sub>el</sub> = 60W, T <sub>J</sub> = 125°C)	T <sub>C</sub>	75	°C
Soldering Temperature <sup>[4]</sup>	T <sub>sol</sub>	260	°C
Allowable Reflow Cycles		6	
ESD Sensitivity <sup>[5]</sup>		ESD Sensitive Device Class 0 ANSI/ ESDA/ JEDEC JS-001 HBM	

Notes for Table 4:

- Pulse forward current conditions: Pulse Width ≤ 10msec and Duty Cycle ≤ 10%.
- Maximum electrical input power is determined by the case temperature and thermal resistance of the package. Refer to curve in Figure 11.
- LEDs are not designed to be reverse biased.
- Solder conditions per JEDEC 020D. See Reflow Soldering Profile Figure 3.
- LED Engin recommends taking reasonable precautions towards possible ESD damages and handling the emitter in an electrostatic protected area (EPA). An EPA may be adequately protected by ESD controls as outlined in ANSI/ESD S6.1.

Optical Characteristics @T<sub>C</sub> = 25°C

Table 5:

Parameter	Symbol	Typical						Unit
		1xRed	1xGreen	1xBlue <sup>[1]</sup>	1xPC Amber	1xCyan	2xPC Lime	
Luminous Flux (@ I <sub>F</sub> = 1000mA)	Φ <sub>V</sub>	95	180	42 (1.2W)	140	135	620	lm
Luminous Flux (@ I <sub>F_Max</sub> )	Φ <sub>V</sub>	190	340	97 (2.8W)	182	135	1240	lm
Dominant Wavelength (@ I <sub>F</sub> = 1000mA)	λ <sub>D</sub>	623	520	451	590	500		nm
Viewing Angle <sup>[2]</sup>	2Θ <sub>½</sub>				114			Degrees
Total Included Angle <sup>[3]</sup>	Θ <sub>0.9</sub>				156			Degrees

Notes for Table 5:

- When operating the Blue LED, observe IEC 62471 Risk Group 3 rating. Do not stare into the beam.
- Viewing Angle is the off axis angle from emitter centerline where the luminous intensity is ½ of the peak value.
- Total included Angle is the total angle that includes 90% of the total luminous flux.

## LZ7-04M2PD

### Electrical Characteristics @T<sub>c</sub> = 25°C

Table 6:

Parameter	Symbol	Soak Requirements						Unit
		1xRed	1xGreen	1xBlue	1xPC Amber	1xCyan	2xPC Lime	
Forward Voltage (@ I <sub>F</sub> = 1000mA)	V <sub>F</sub>	2.3	3.6	3.1	3.6	3.6	6.4	V
Temperature Coefficient of Forward Voltage	ΔV <sub>F</sub> /ΔT <sub>J</sub>	-1.9	-4.2	-1.8	-3.2	-2.6	-3.6	mV/°C
Thermal Resistance, electrical (Junction to Case)	RO <sub>J-C, el</sub>				0.8			°C/W

### IPC/JEDEC Moisture Sensitivity Level

Table 7 - IPC/JEDEC J-STD-20D.1 MSL Classification:

Level	Floor Life		Standard		Accelerated	
	Time	Conditions	Time (hrs)	Conditions	Time (hrs)	Conditions
1	Unlimited	≤ 30°C/ 85% RH	168 +5/-0	85°C/ 85% RH	n/a	n/a

Notes for Table 7:

- The standard soak time includes a default value of 24 hours for semiconductor manufacturer's exposure time (MET) between bake and bag and includes the maximum time allowed out of the bag at the distributor's facility.

**LZ7-04M2PD**

**Mechanical Dimensions (mm)**

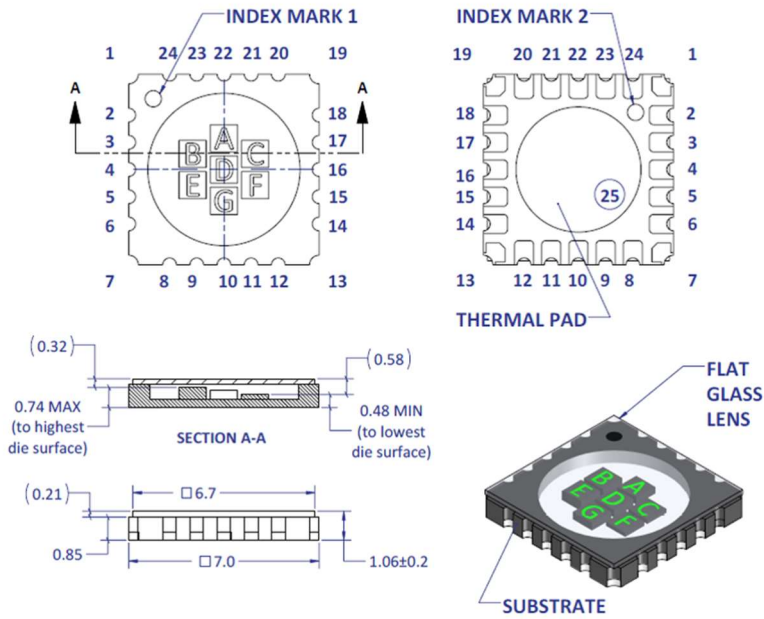

Figure 1: Package Outline Drawing

Notes for Figure 1:

1. Unless otherwise noted, the tolerance =  $\pm 0.20$  mm.
2. Thermal contact, Pad 25, is electrically neutral.
3. Tc (case temperature) point is Pad 25. Because it is not easily accessible, the recommended temperature measurement point is pin 1 (or any of the corner pins).

Pin Out			
Pin	Die	Color	Polarity
2	B	Red	+
3	A	Blue	+
5	C	Green	+
6	F	PC Lime	+
8	E	PC Lime	+
9	G	PC Amber	+
11	D	Cyan	-
14	D	Cyan	+
15	G	PC Amber	-
17	E	PC Lime	-
20	F	PC Lime	-
21	C	Green	-
23	A	Blue	-
NC pins: 1, 4, 7, 10, 12, 13, 16, 18, 19, 22.			
DNC pins: none			

Note:

NC = Not Internally Connected  
(Electrically Isolated)

DNC = Do Not Connect (Electrically Non Isolated)

**Recommended Solder Pad Layout (mm) – Pedestal MCPCB Design**

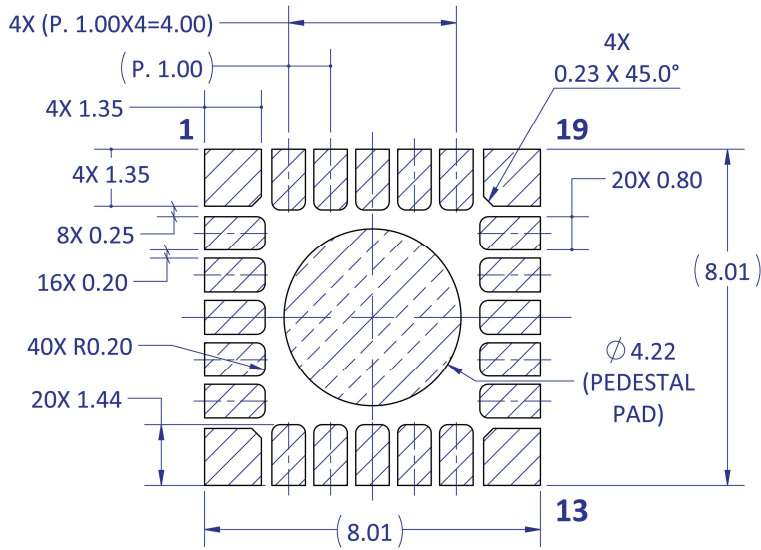

Figure 2a: Recommended solder pad layout for anode, cathode, and thermal pad for pedestal design

Note for Figure 2a:

1. Unless otherwise noted, the tolerance =  $\pm 0.20$  mm.
2. Pedestal MCPCB allows the emitter thermal slug to be soldered directly to the metal core of the MCPCB. Such MCPCB eliminate the high thermal resistance dielectric layer that standard MCPCB technologies use in between the emitter thermal slug and the metal core of the MCPCB, thus lowering the overall system thermal resistance.
3. LED Engin recommends x-ray sample monitoring for solder voids underneath the emitter thermal slug. The total area covered by solder voids should be less than 20% of the total emitter thermal slug area. Excessive solder voids will increase the emitter to MCPCB thermal resistance and may lead to higher failure rates due to thermal over stress.

**Recommended Solder Mask Layout (mm) – Pedestal MCPCB Design**

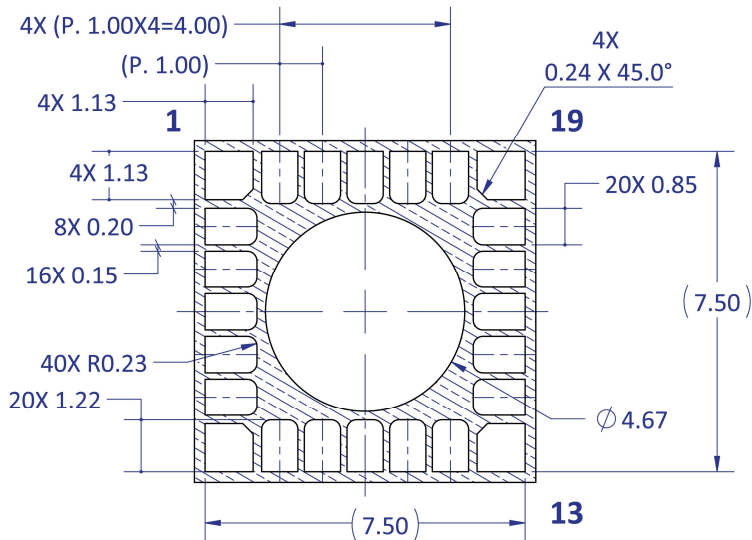

Figure 2b: Recommended solder mask opening for anode, cathode, and thermal pad for pedestal design

Note for Figure 2b:

1. Unless otherwise noted, the tolerance =  $\pm 0.20$  mm.

Recommended 8 mil Stencil Apertures Layout (mm) – Pedestal MCPCB Design

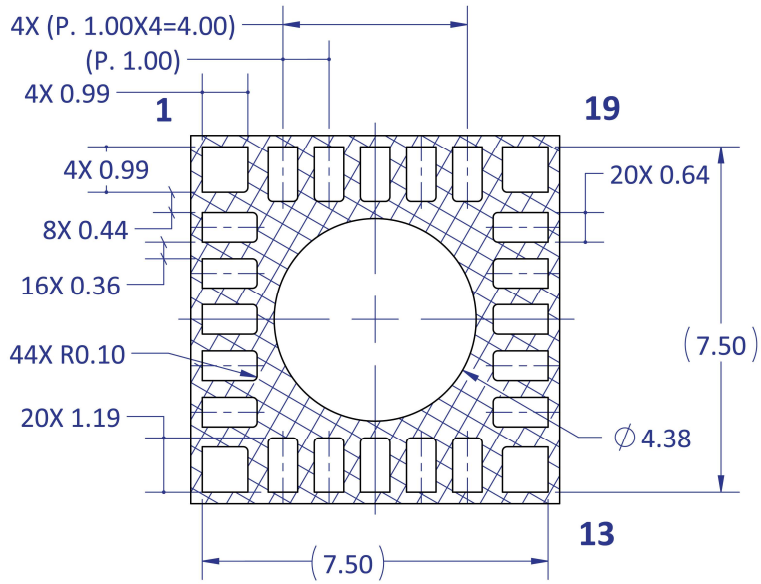

Figure 2c: Recommended 8mil stencil apertures layout for anode, cathode, and thermal pad for pedestal design

Note for Figure 2c:

1. Unless otherwise noted, the tolerance = ± 0.20 mm.

Reflow Soldering Profile

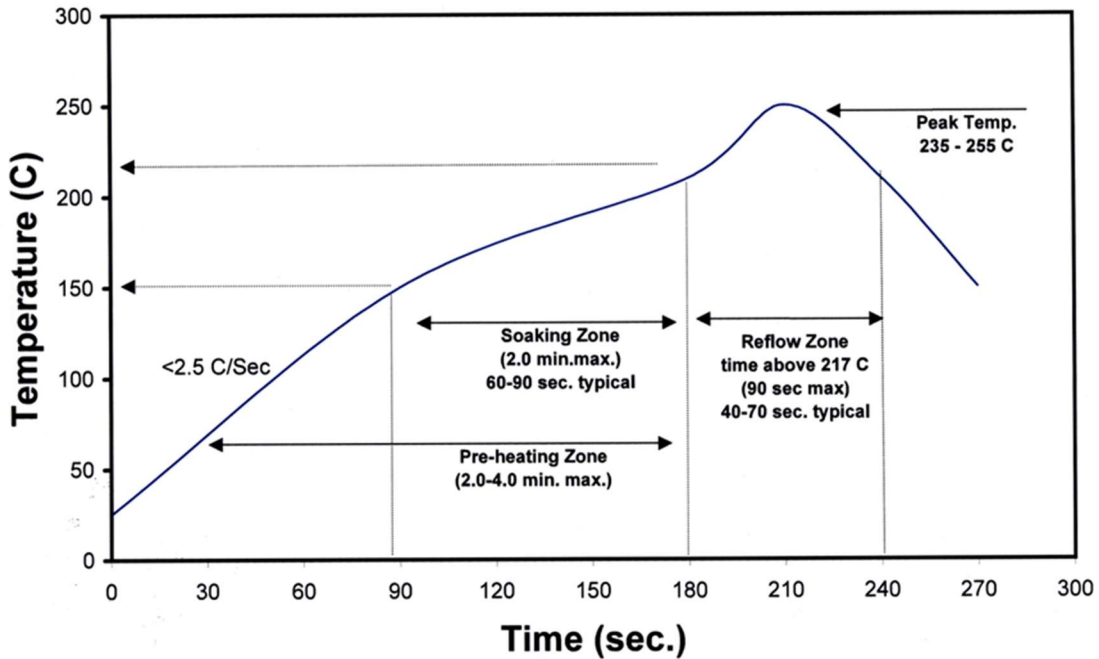

Figure 3: Reflow soldering profile for lead free soldering

Typical Radiation Pattern

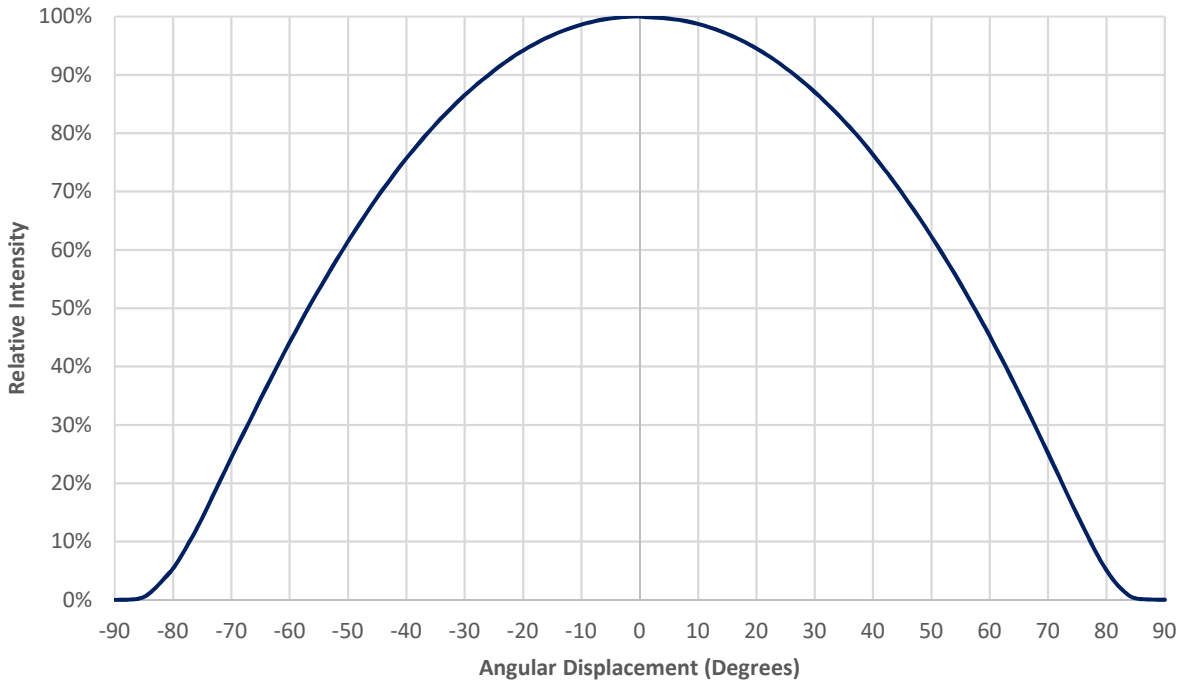

Figure 4: Typical representative spatial radiation pattern – all dies on

Typical Relative Spectral Power Distribution

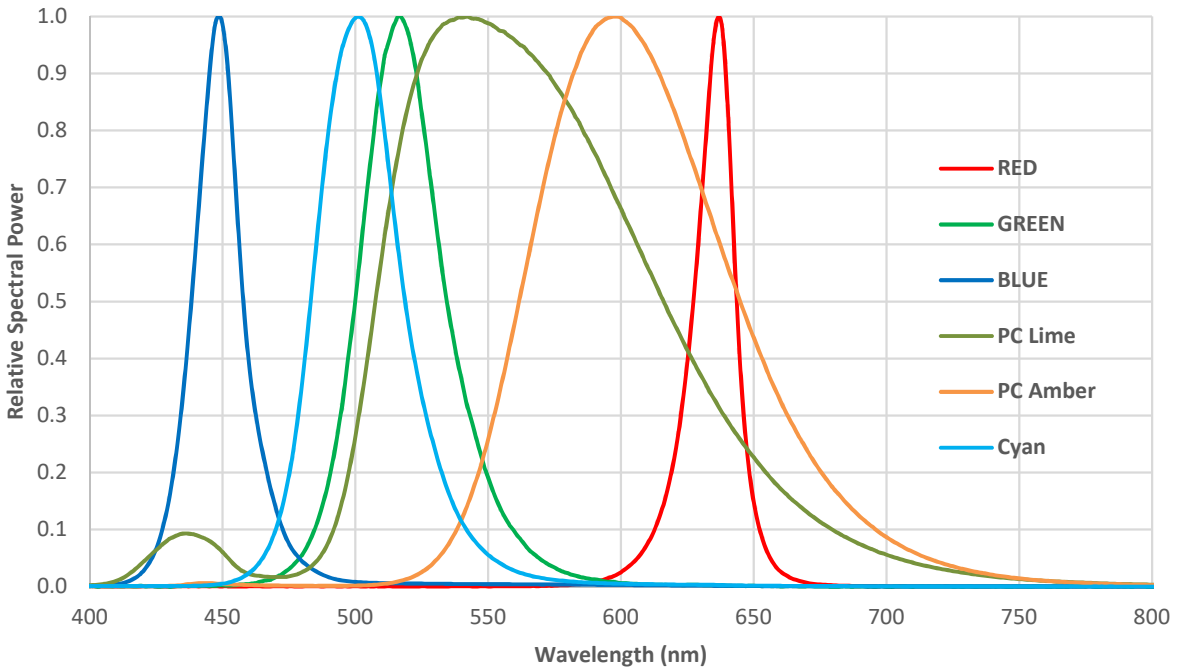

Figure 5: Typical relative spectral power vs. wavelength @ T<sub>c</sub> = 25°C, 1000mA, pulse

Typical Forward Current Characteristics

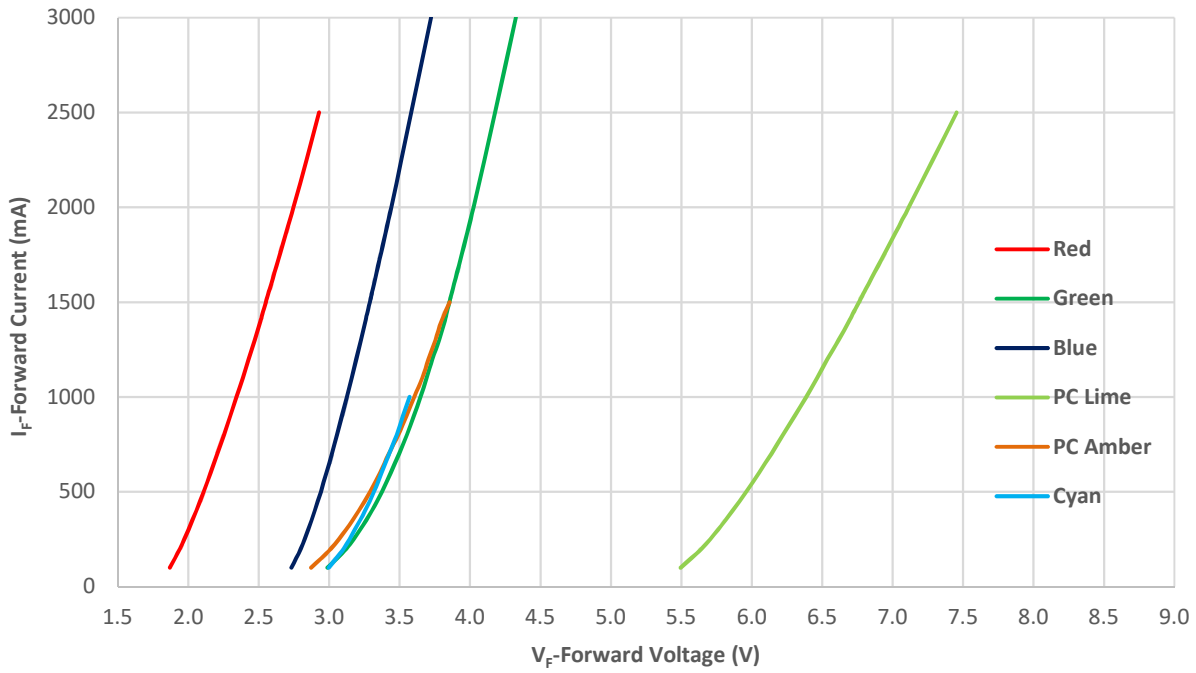

Figure 6: Typical forward current vs. Forward voltage @ Tc = 25°C, pulse

Note for Figure 6:

1. PC Lime curve represents forward voltage of 2 PC Lime dies connected in series.

Typical Relative Flux over Current

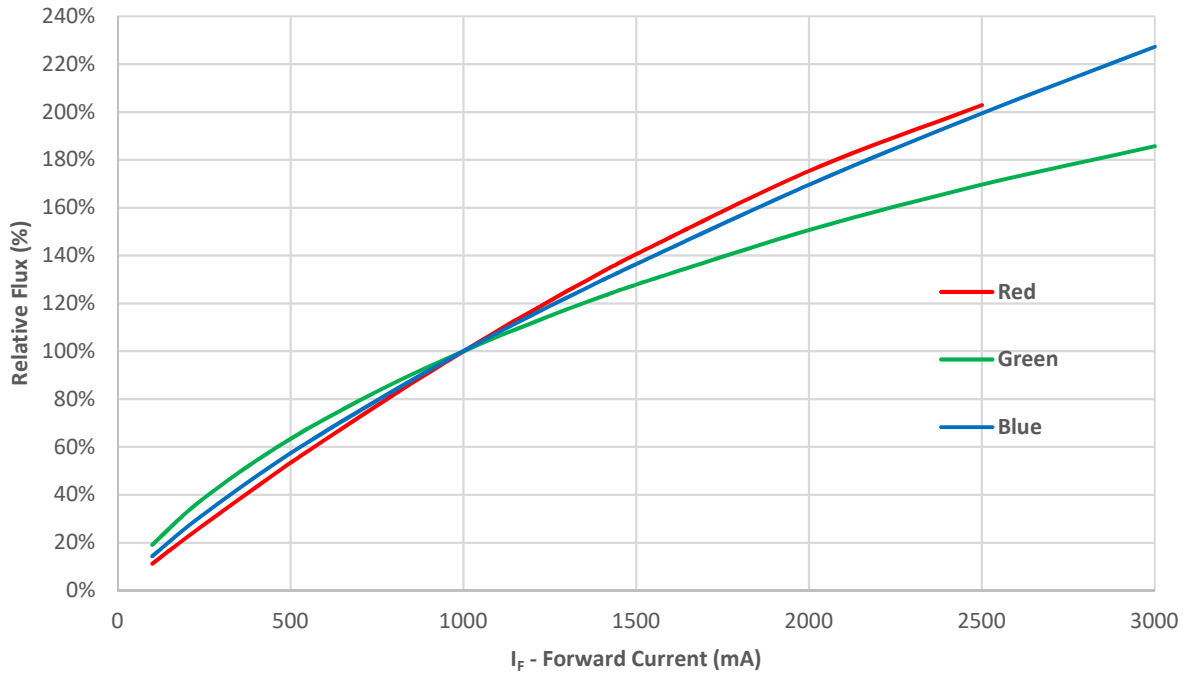

Figure 7a: Typical relative luminous flux vs. forward current @ Tc = 25°C, pulse – R, G, B

## LZ7-04M2PD

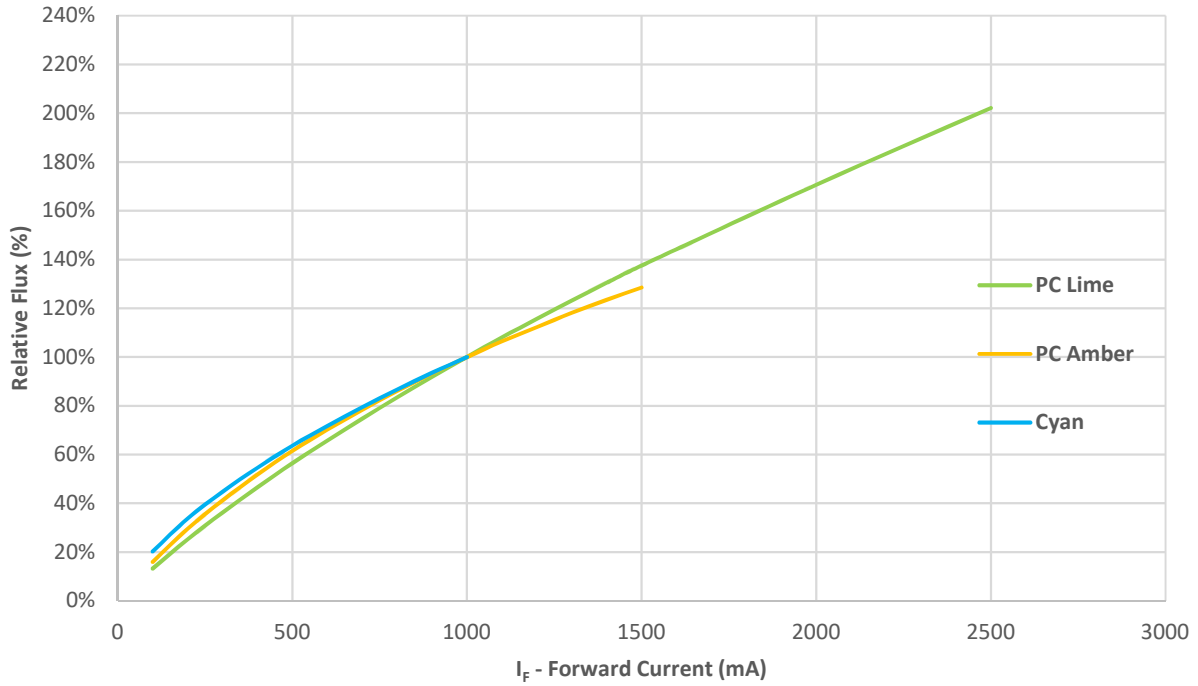

Figure 7b: Typical relative luminous flux vs. forward current @ TC = 25°C, pulse – PCL, PCA, Cyan

## Typical Relative Flux over Temperature

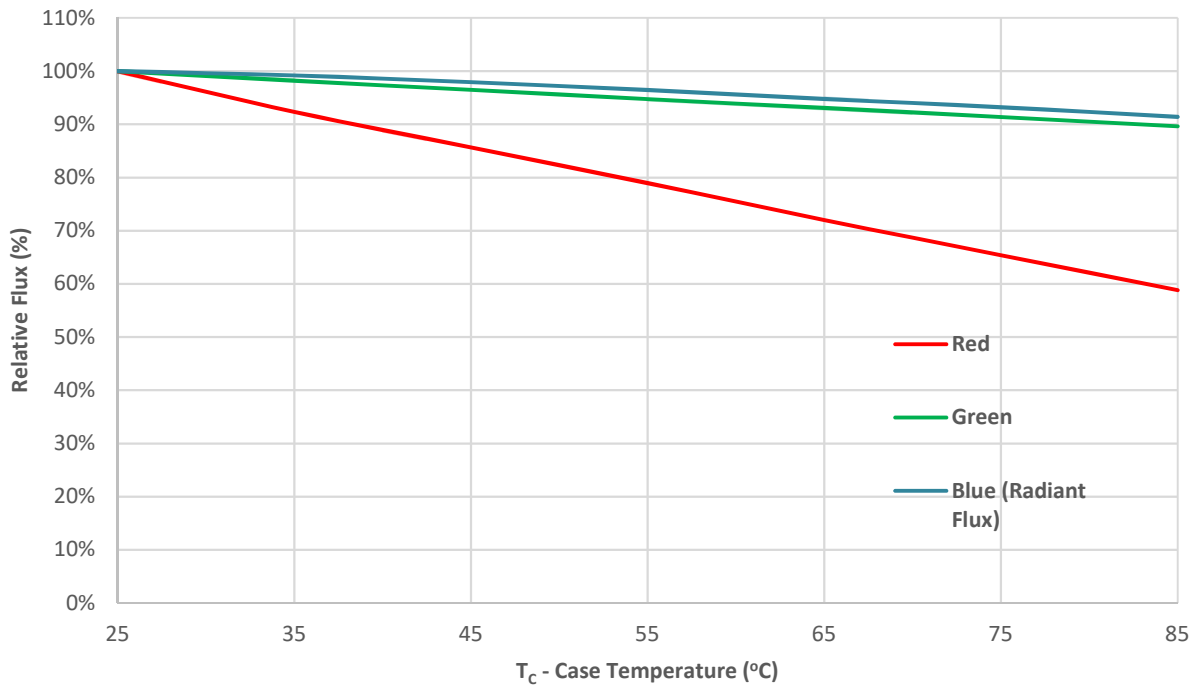

Figure 8a: Typical relative luminous flux vs. case temperature @1000mA, pulse – R, G, B

## LZ7-04M2PD

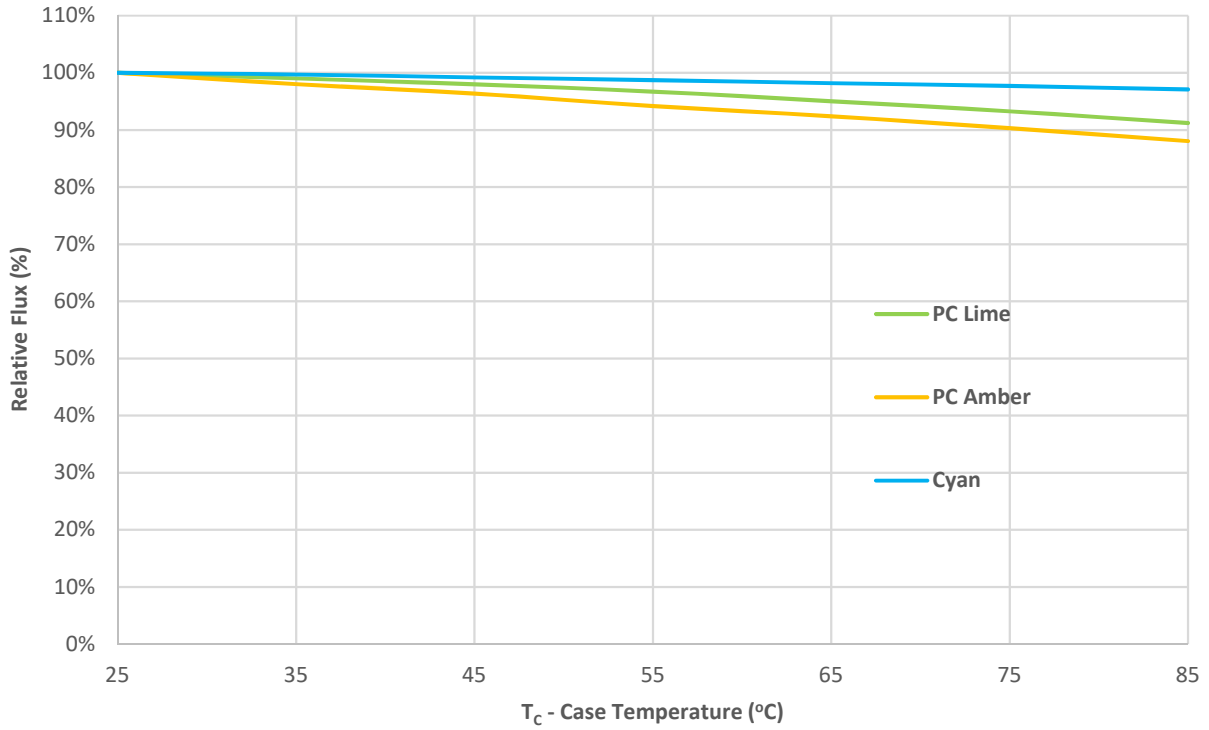

Figure 8b: Typical relative luminous flux vs. case temperature @ 1000mA, pulse – PCL, PCA, Cyan

## Typical Dominant Wavelength Shift over Current

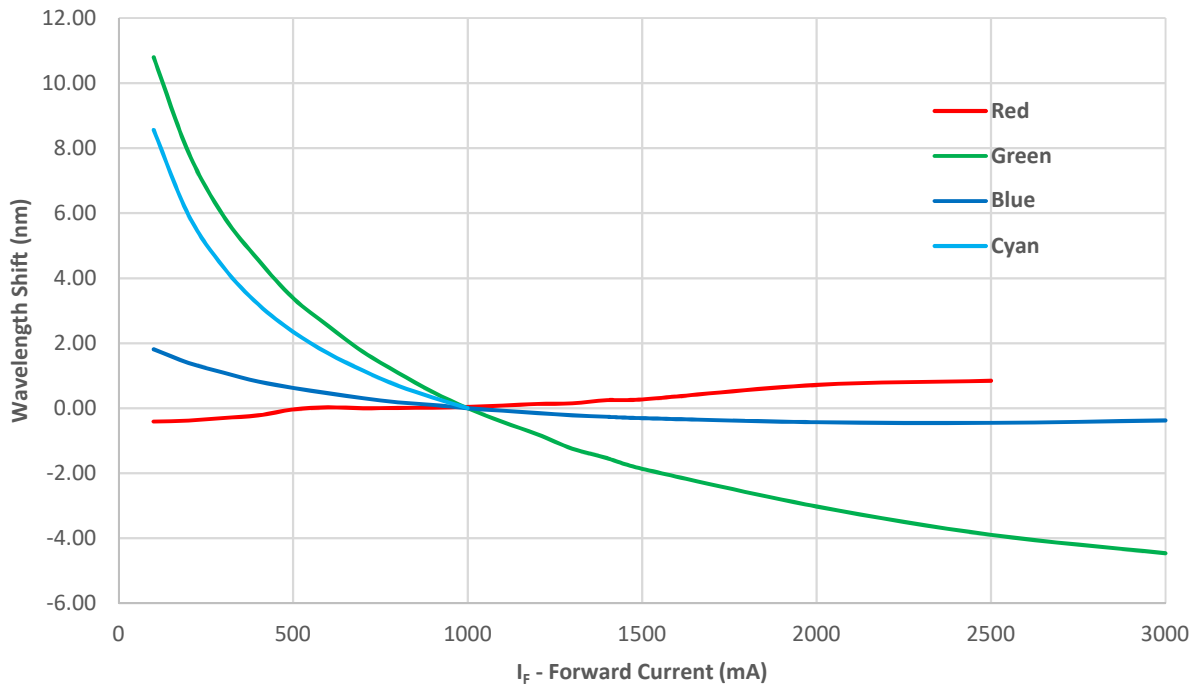

Figure 9a: Typical dominant wavelength shift vs. forward current @ T<sub>c</sub> = 25°C, pulse – R, G, B, Cyan

Typical Chromaticity Coordinate Shift over Current

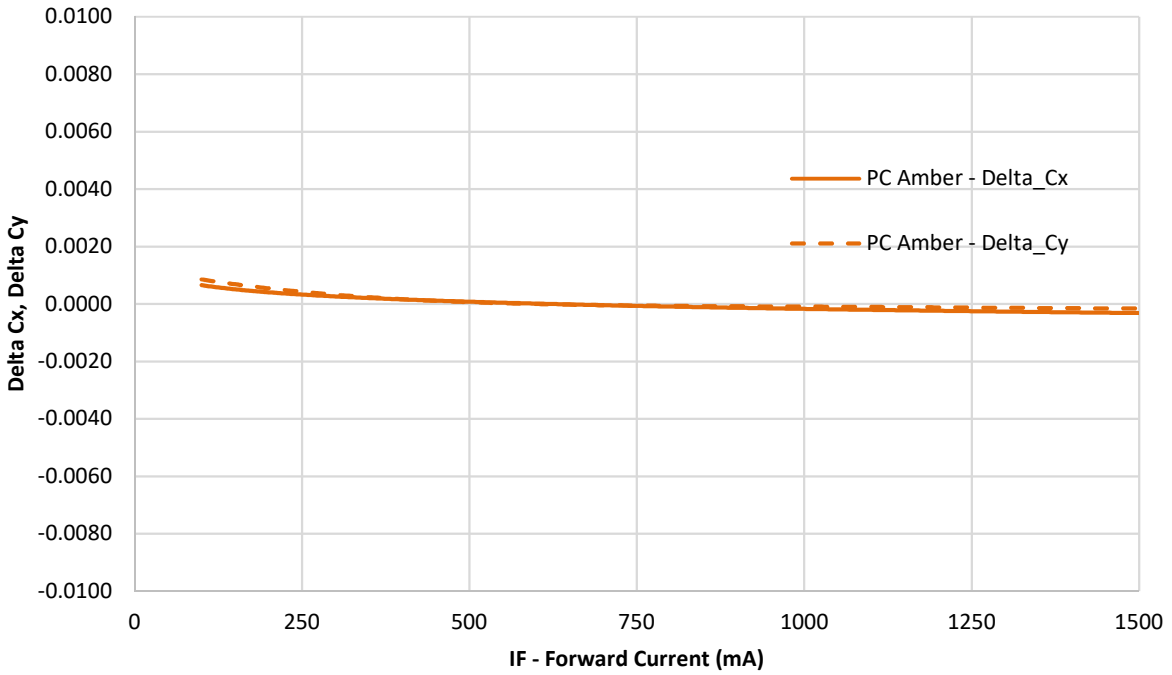

Figure 9b: Typical chromaticity coordinate shift vs. forward current @  $T_c = 25^\circ\text{C}$ , pulse – PC Amber

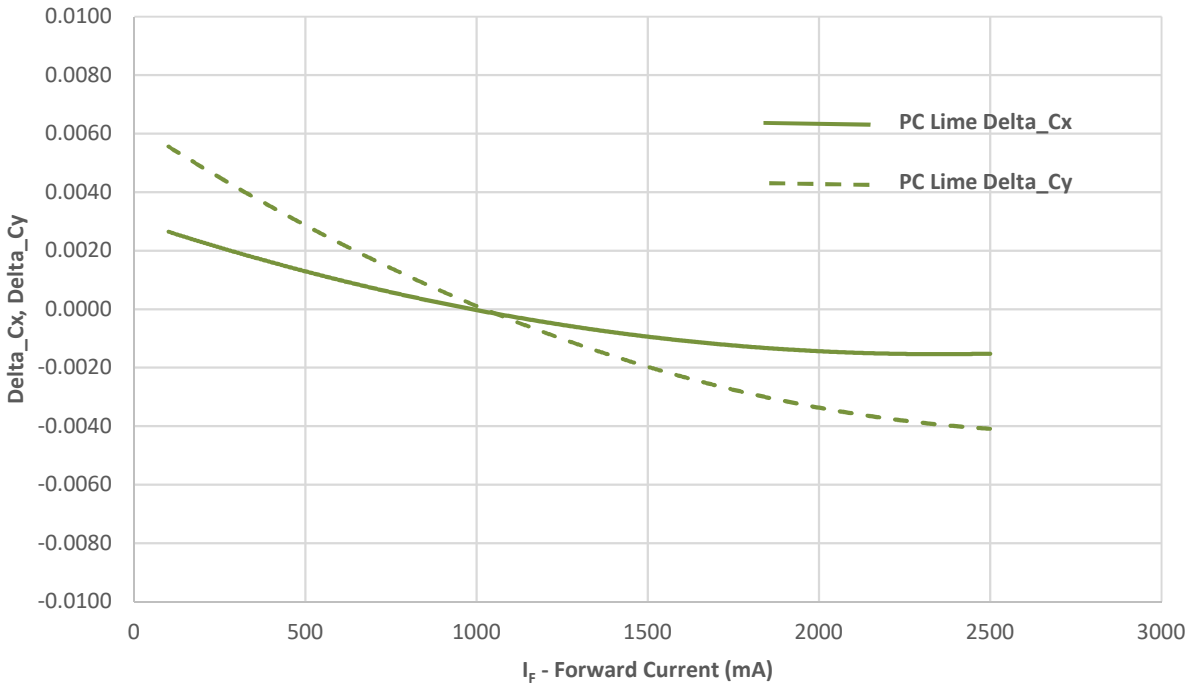

Figure 9c: Typical chromaticity coordinate shift vs. forward current @  $T_c = 25^\circ\text{C}$ , pulse – PC Lime

Typical Dominant Wavelength Shift over Temperature

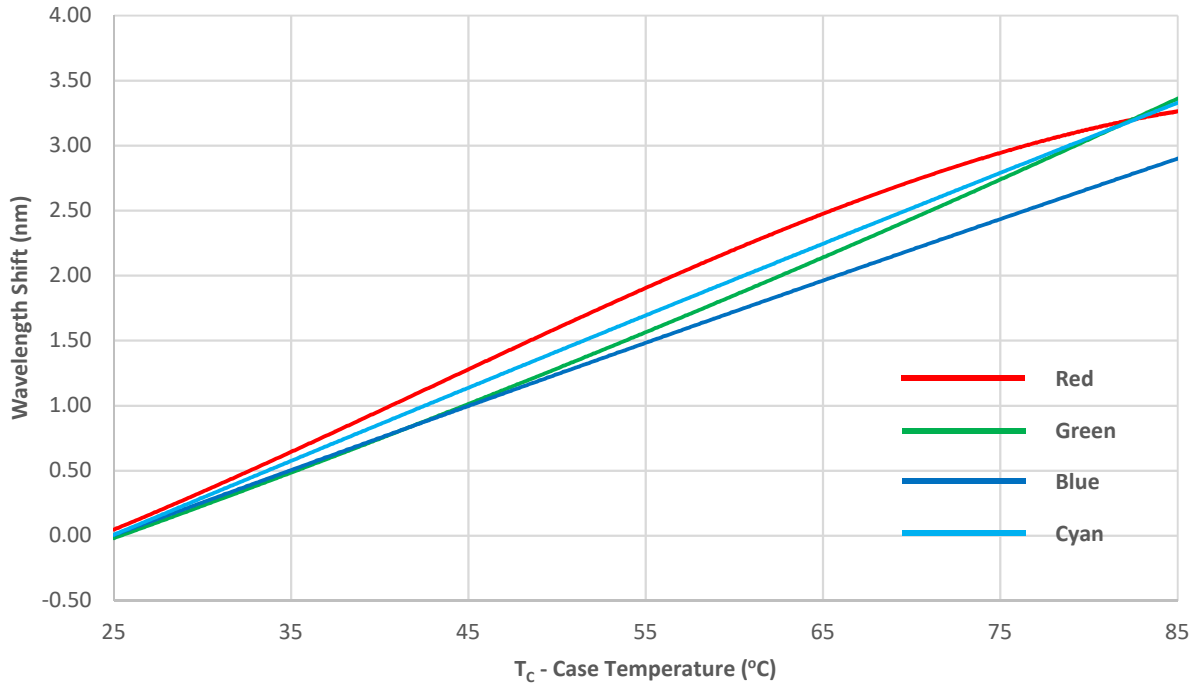

Figure 10a: Typical dominant wavelength shift vs. case temperature @ 1000mA, pulse – R, G, B, Cyan

Typical Chromaticity Coordinate Shift over Temperature

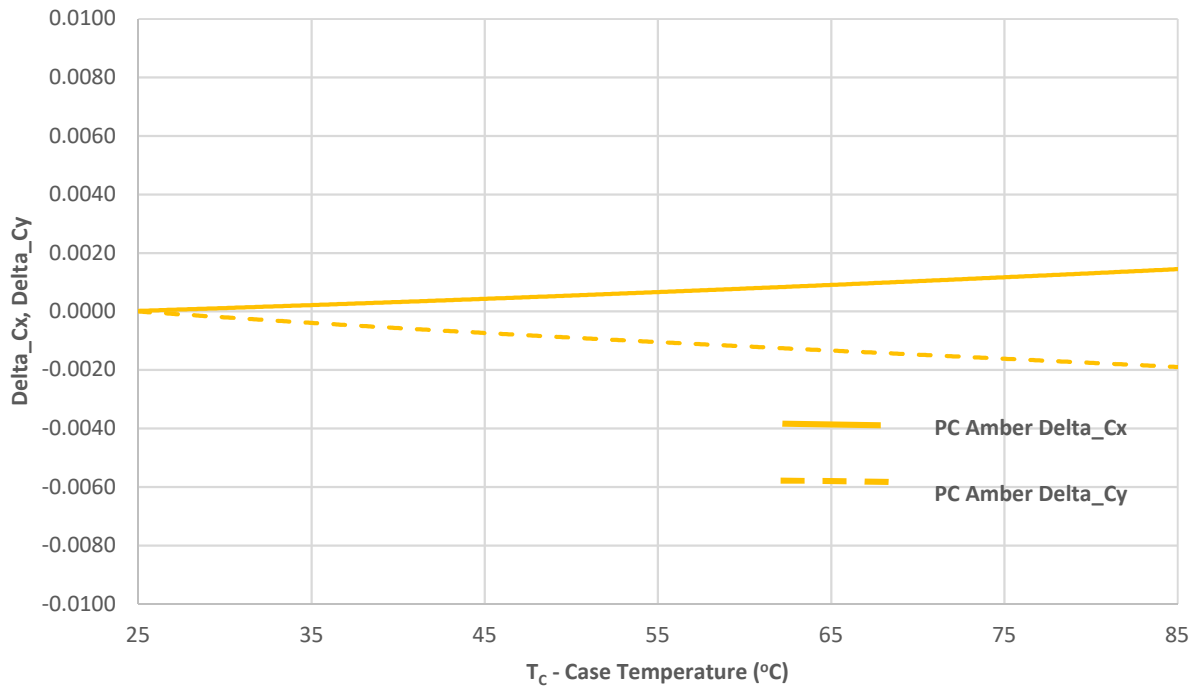

Figure 10b: Typical chromaticity coordinate shift vs. case temperature @1000mA, pulse – PC Amber

**LZ7-04M2PD**

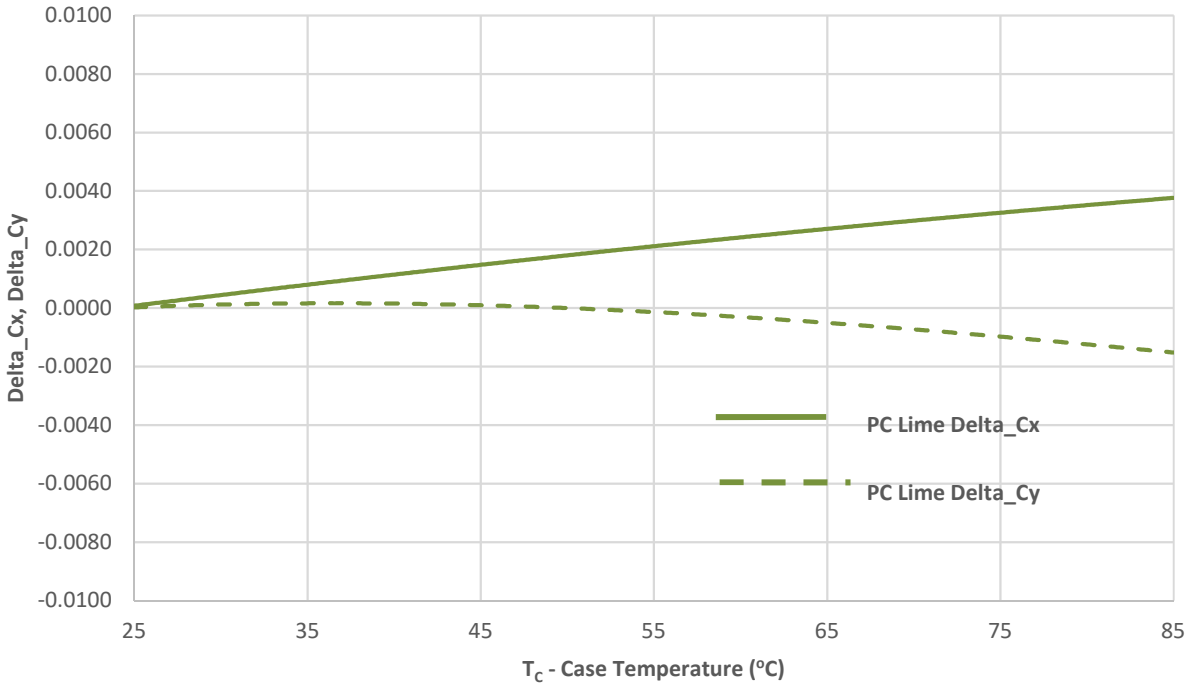

Figure 10c: Typical chromaticity coordinate shift vs. case temperature @ 1000mA, pulse – PC Lime

**Maximum Electrical Input Power over Temperature**

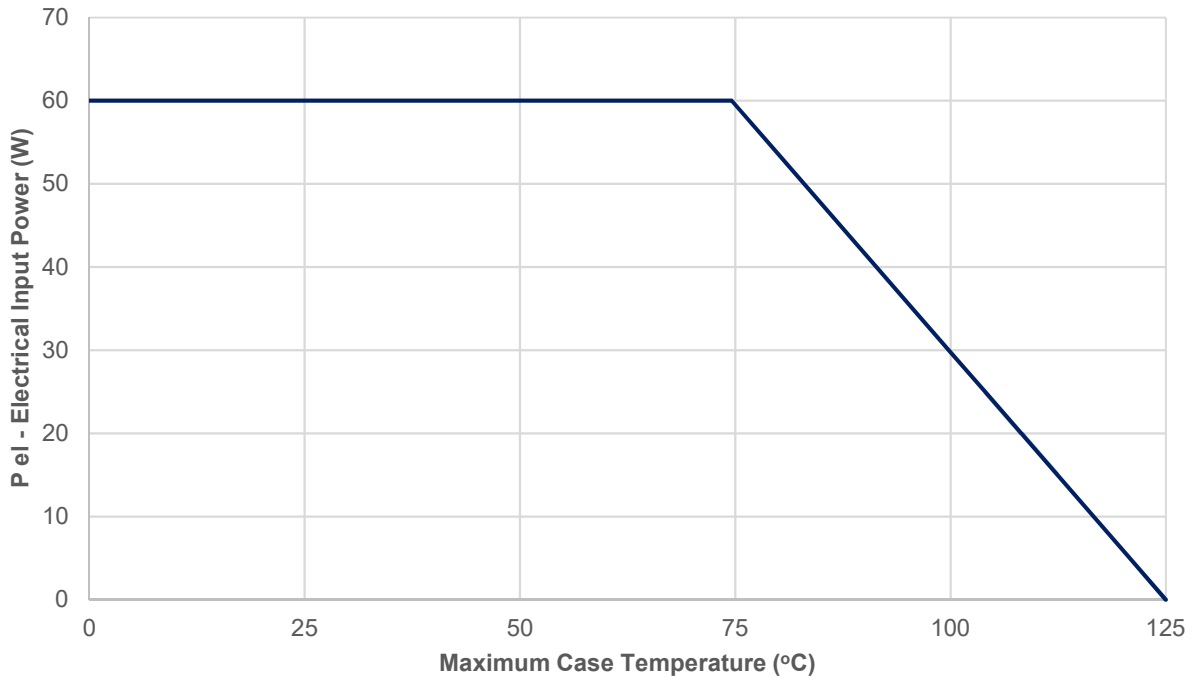

Figure 11: Maximum electrical input power vs. case temperature

Notes for Figure 11:

1.  $R_{\theta J-C}$  [Junction to Case Thermal Resistance] for LZ7-04M2PD is 0.8°C/W.

Emitter Tape and Reel Specifications (mm)

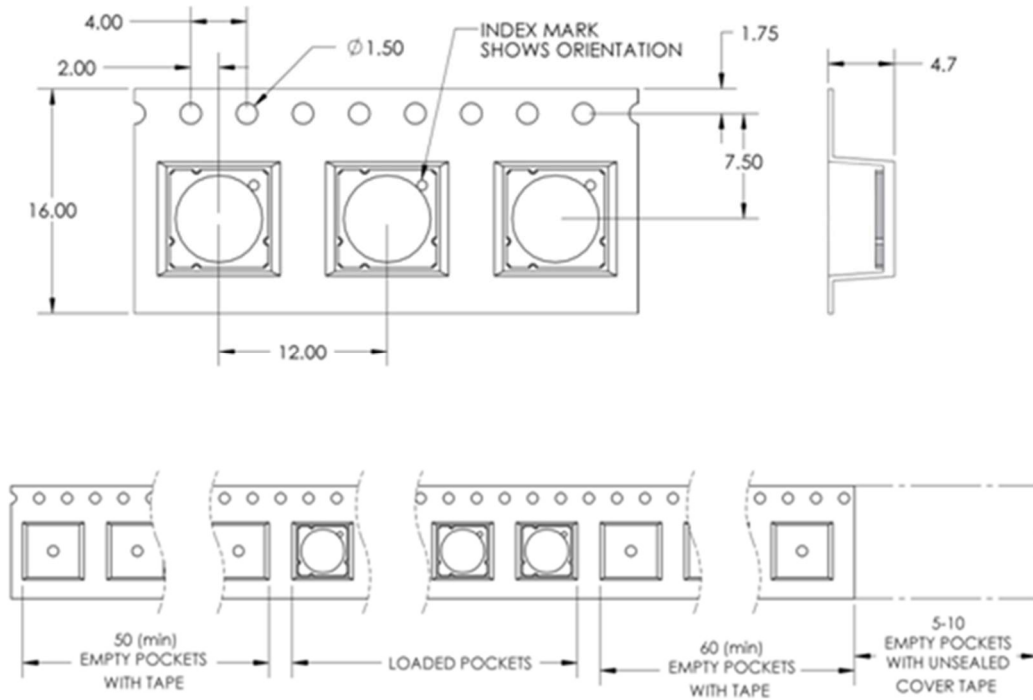

Figure 12: Emitter carrier tape specifications (mm).

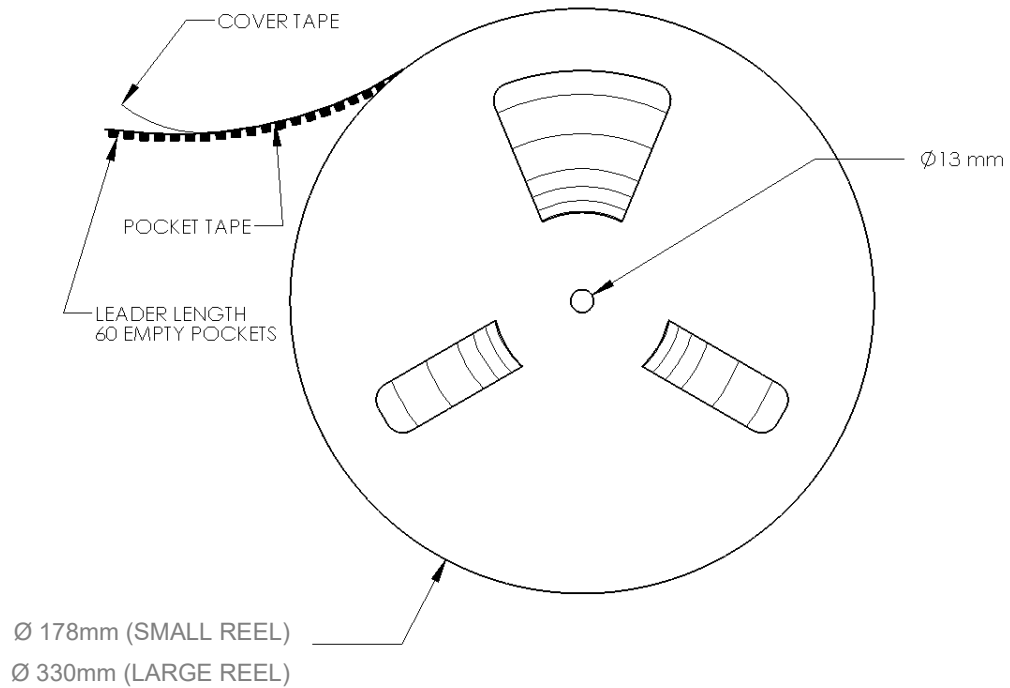

Figure 13: Emitter reel specifications (mm).

Notes for Figure 13:

1. Small reel quantity: up to 500 emitters
2. Large reel quantity: 500-2000 emitters.
3. Single flux bin and single wavelength bin per reel.

## LZ7 MCPCB Family

Part number	Type of MCPCB	Dimension (mm)	Emitter + MCPCB Thermal Resistance (°C/W)	Typical $V_f$ (V)	Typical $I_f$ (mA)
LZ7-Axxxxx	7-channel	38.3 x 31.2	$0.8 + 0.1 = 0.9$	2.3 – 3.6	1000

LZ7-Axxxxx

7 channel, MCPCB (7x1) Dimensions (mm)

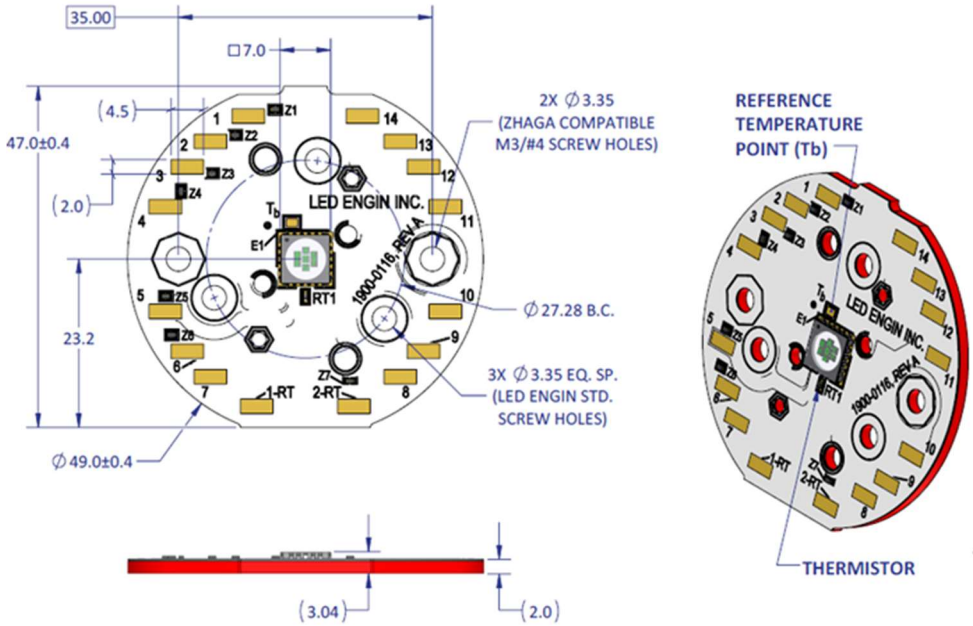

Notes:

1. Unless otherwise noted, the tolerance = ± 0.2 mm.
2. Standard screw refers to M3 or #4-40 screw.
3. The thermal resistance of the MCPCB is: RθC-B 0.1°C/W
4. Tb is the recommended point to attach thermocouple.

Components used

MCPCB: MHE-301 copper (Rayben)  
 Thermistor: NCP15XH103F03RC (Murata)

Pad layout			
Ch.	MCPCB Pad	Die/ Color	Function
1	1	B/ Red	Anode +
	14		Cathode -
2	2	A/ Blue	Anode +
	13		Cathode -
3	3	C/ Green	Anode +
	12		Cathode -
4	4	F/ PC	Anode +
	11	Lime	Cathode -

Pad layout			
Ch.	MCPCB Pad	Die/ Color	Function
5	5	E/ PC	Anode +
	10	Lime	Cathode -
6	6	G/ PC	Anode +
	9	Amber	Cathode -
7	7	D/ Cyan	Cathode -
	8		Anode +
T	1-RT	NTC	10kOhm
	2-RT		NTC

## Application Guidelines

### MCPCB Assembly Recommendations

A good thermal design requires an efficient heat transfer from the MCPCB to the heat sink. In order to minimize air gaps in between the MCPCB and the heat sink, it is common practice to use thermal interface materials such as thermal pastes, thermal pads, phase change materials and thermal epoxies. Each material has its pros and cons depending on the design. Thermal interface materials are most efficient when the mating surfaces of the MCPCB and the heat sink are flat and smooth. Rough and uneven surfaces may cause gaps with higher thermal resistances, increasing the overall thermal resistance of this interface. It is critical that the thermal resistance of the interface is low, allowing for an efficient heat transfer to the heat sink and keeping MCPCB temperatures low. When optimizing the thermal performance, attention must also be paid to the amount of stress that is applied on the MCPCB. Too much stress can cause the ceramic emitter to crack. To relax some of the stress, it is advisable to use plastic washers between the screw head and the MCPCB and to follow the torque range listed below. For applications where the heat sink temperature can be above 50°C, it is recommended to use high temperature and rigid plastic washers, such as polycarbonate or glass-filled nylon.

### LED Engin recommends the use of the following thermal interface materials:

1. Bergquist's Gap Pad 5000S35, 0.020in thick
  - Part Number: Gap Pad® 5000S35 0.020in/0.508mm
  - Thickness: 0.020in/0.508mm
  - Thermal conductivity: 5 W/m-K
  - Continuous use max temperature: 200°C
  - Using M3 Screw (or #4 screw), with polycarbonate or glass-filled nylon washer (#4) the recommended torque range is: 20 to 25 oz-in (1.25 to 1.56 lbf-in or 0.14 to 0.18 N-m)
  
2. 3M's Acrylic Interface Pad 5590H
  - Part number: 5590H @ 0.5mm
  - Thickness: 0.020in/0.508mm
  - Thermal conductivity: 3 W/m-K
  - Continuous use max temperature: 100°C
  - Using M3 Screw (or #4 screw), with polycarbonate or glass-filled nylon washer (#4) the recommended torque range is: 20 to 25 oz-in (1.25 to 1.56 lbf-in or 0.14 to 0.18 N-m)

### Mechanical Mounting Considerations

The mounting of MCPCB assembly is a critical process step. Excessive mechanical stress build up in the MCPCB can cause the MCPCB to warp which can lead to emitter substrate cracking and subsequent cracking of the LED dies

**LED Engin recommends the following steps to avoid mechanical stress build up in the MCPCB:**

- Inspect MCPCB and heat sink for flatness and smoothness.
- Select appropriate torque for mounting screws. Screw torque depends on the MCPCB mounting method (thermal interface materials, screws, and washer).
- Always use three M3 or #4-40 screws with #4 washers.
- When fastening the three screws, it is recommended to tighten the screws in multiple small steps. This method avoids building stress by tilting the MCPCB when one screw is tightened in a single step.
- Always use plastic washers in combinations with the three screws. This avoids high point contact stress on the screw head to MCPCB interface, in case the screw is not seated perpendicular.
- In designs with non-tapped holes using self-tapping screws, it is common practice to follow a method of three turns tapping a hole clockwise, followed by half a turn anti-clockwise, until the appropriate torque is reached.

**Wire Soldering**

- To ease soldering wire to MCPCB process, it is advised to preheat the MCPCB on a hot plate of 125-150°C. Subsequently, apply the solder and additional heat from the solder iron will initiate a good solder reflow. It is recommended to use a solder iron of more than 60W.
- It is advised to use lead-free, no-clean solder. For example: SN-96.5 AG-3.0 CU 0.5 #58/275 from Kester (pn: 24-7068-7601)

LZ7-04M2PD

## About LED Engin

LED Engin, an OSRAM brand based in California's Silicon Valley, develops, manufactures, and sells advanced LED emitters, optics and light engines to create uncompromised lighting experiences for a wide range of entertainment, architectural, general lighting and specialty applications. LuxiGen™ multi-die emitter and secondary lens combinations reliably deliver industry-leading flux density, upwards of 5000 quality lumens to a target, in a wide spectrum of colors including whites, tunable whites, multi-color and UV LEDs in a unique patented compact ceramic package. Our LuxiTune™ series of tunable white lighting modules leverage our LuxiGen emitters and lenses to deliver quality, control, freedom and high density tunable white light solutions for a broad range of new recessed and downlighting applications. The small size, yet remarkably powerful beam output and superior in-source color mixing, allows for a previously unobtainable freedom of design wherever high-flux density, directional light is required. LED Engin is committed to providing products that conserve natural resources and reduce greenhouse emissions; and reserves the right to make changes to improve performance without notice.

For more information, please contact [LEDE-Sales@osram.com](mailto:LEDE-Sales@osram.com) or +1 408 922-7200.

OSRAM SYLVANIA Inc.

LED Engin office:  
651 River Oaks Parkway  
San Jose, CA 95134  
USA  
408 922-7200  
[LEDE-Sales@osram.com](mailto:LEDE-Sales@osram.com)  
[www.osram.us/ledengin](http://www.osram.us/ledengin)

Our Brand

LED ENGIN



**OSRAM**  
Opto Semiconductors