

1. Features

- Small footprint Buck converter for up to 3A output current application
- Low EMI noise using an inductor-embedded ferrite substrate
- Input voltage range : 2.7 to 5.5V
- User Adjustable Output voltage : 0.8 to 3.6V
- PWM/PFM mode
- Powergood function
- Over current protection, Over temperature protection

2. Mechanical Details

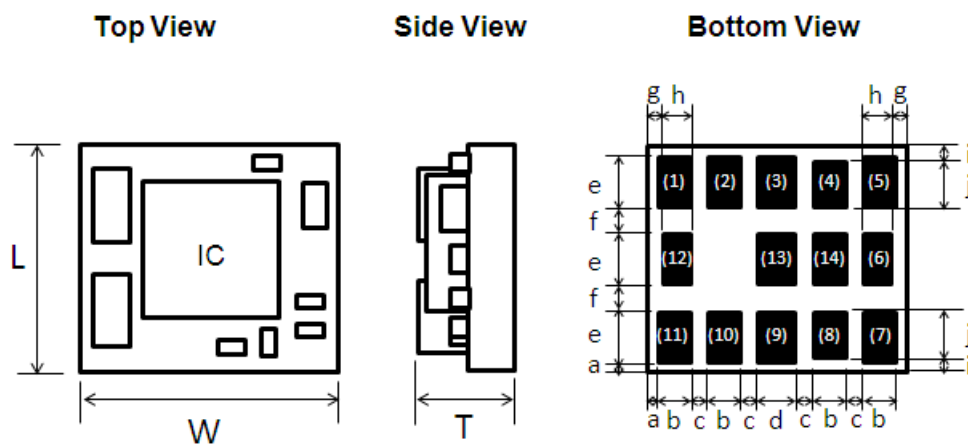

Unit:mm

Mark	Dimension	Mark	Dimension
L	5.0 +/- 0.2	e	1.1
W	5.7 +/- 0.2	f	0.6
T	2.1 MAX	g	0.35
a	0.25	h	0.6
b	0.7	i	0.35
c	0.4	j	1.0
d	0.8		

Pin configuration

Pin No.	Symbol	I/O	Description
1	EN	Input	ON/OFF control pin H: Enable, L: Disable
4,5	Vin	Input	Power supply voltage Input pin
6,12	GND	-	GND pin
7,8	Vout	Output	Regulated voltage output pin
10	PG	Output	Power good output pin H: Normal Operation
11	FB	Input	External resistor connection pin for output voltage setting
2,3,9,13,14	NC	-	No connection This pin can be connected to any other pins

3. Electrical Specification

3-1 Absolute maximum ratings

Parameter	symbol	rating	Unit
Maximum input voltage	V _{in}	6	V
Maximum EN pin voltage	V _{EN}	6	V
Maximum FB pin voltage	V _{FB}	6	V
Maximum PG pin voltage	V _{PG}	V _{in}	V
Operating temperature	T _{OP}	-40 to +85	°C
Storage temperature	T _{STO}	-40 to +85	°C

3-2 Electrical characteristics (Ta=25°C)

Parameter	Symbol	Condition	Min.	Typ.	Max.	Unit
Input voltage	V _{in}		2.7		5.5	V
Output voltage range	V _{out}		0.8		3.6	V
UVLO	UVLO	V _{in} Falling	2.1	2.2	2.3	V
		hysteresis		200		mV
Output voltage accuracy	V _{acc}	PWM mode	-2.5		+2.5	%
Load current range	I _{out}		0		3000	mA
Over current protection	OCP	Auto-recovery	3000		5500	mA
Ripple voltage	V _{rpl}	V _{in} =5V, RFB=576ohm, (V _{out} =3.3V) I _{out} =1500mA, BW=100MHz		20		mV
Efficiency	EFF	V _{in} =5V, RFB=576ohm, (V _{out} =3.3V) I _{out} =1500mA, BW=100MHz	T.B.D.	93		%
EN control voltage	V _{ENH}	ON ; Enable	1.0		V _{in}	V
	V _{ENL}	OFF ; Disable	0		0.4	V
Power good threshold	PGTHH	Output voltage rising		95		%
	PGTHL	Output voltage falling		90		%
Power good sink current	I _{PG}				1	mA
External output capacitor(*1)	C _{out}		22		150	uF

- (*1) External capacitors (C_{out}>22uF) shall be placed near the module in order to proper operation.
- The above characteristics are tested using the application circuit on section 4.

3-3 Output Current Thermal Derating (Vin=5.0V)

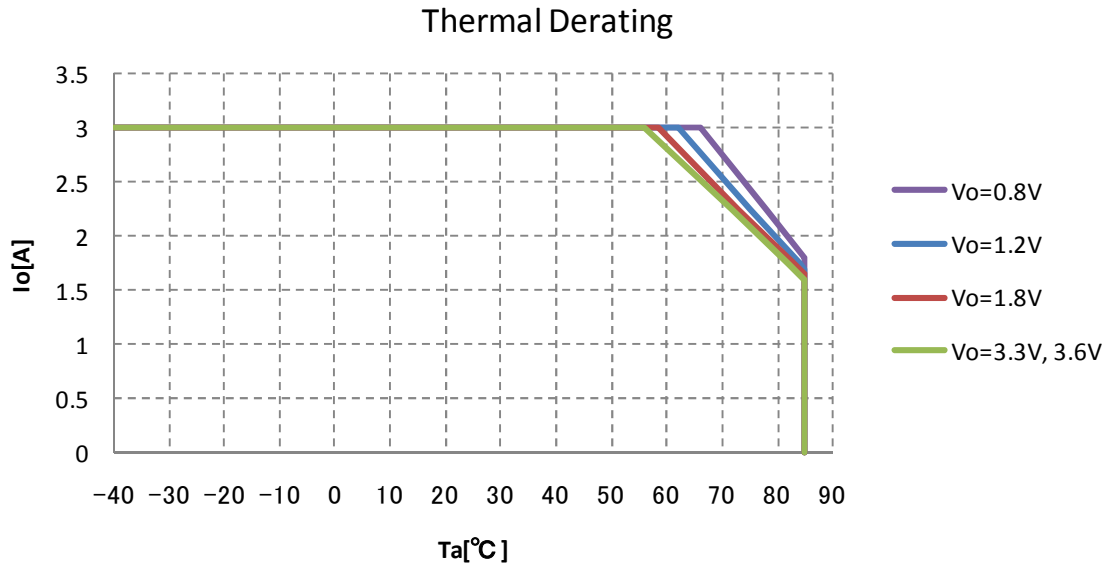

Note: This thermal derating data is measured on Murata evaluation board and reference only. The temperature of the module depends on PCB design and peripheral components. Please keep the module temperature under 105 °C on your board.

4. Application Circuit

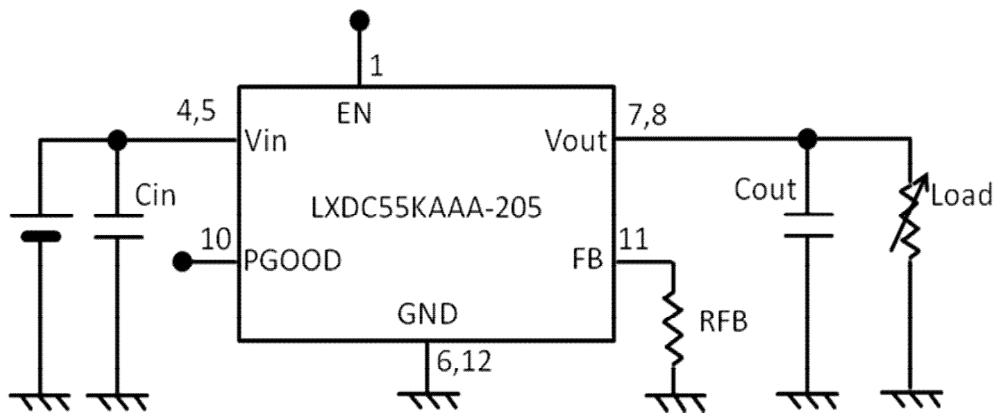

Cin : GRM21BB30J106 (10uF/6.3V MLCC)

Cout : GRM21BB30J226 (22uF/6.3V MLCC)

5. Reference Land Pattern

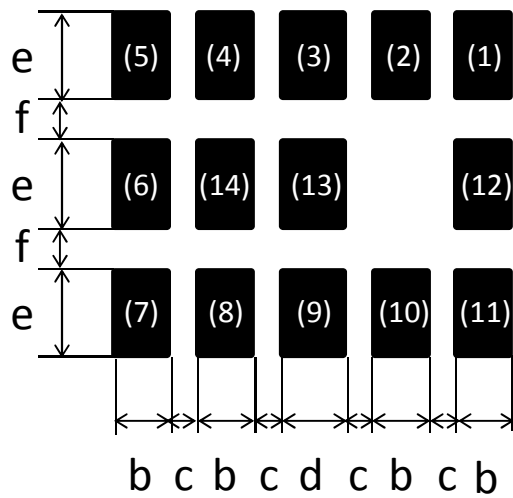

unit (mm)

Mark	Dimension
b	0.7
c	0.4
d	0.8
e	1.1
f	0.6

*Reference purpose only

6. Output Voltage adjustment

Output voltage can be adjusted by using a resistor (RFB) between FB pin and GND pin.

$$RFB = 5.44 / (V_{out} - 0.8V) - 1.6 \text{ [kohm]}$$

RFB Example

Vout(V)	RFB(kohm)	Vout(V)	RFB(kohm)
0.8	OPEN	2.5	1.6
1.2	12	3.0	0.872
1.5	6.17	3.3	0.576
1.8	3.84	3.6	0.342

7. Typical Electric Performance (reference purpose only) (Ta=25°C)

Micro DCDC Converter evaluation board (P2LX1568F)

Measurement setup

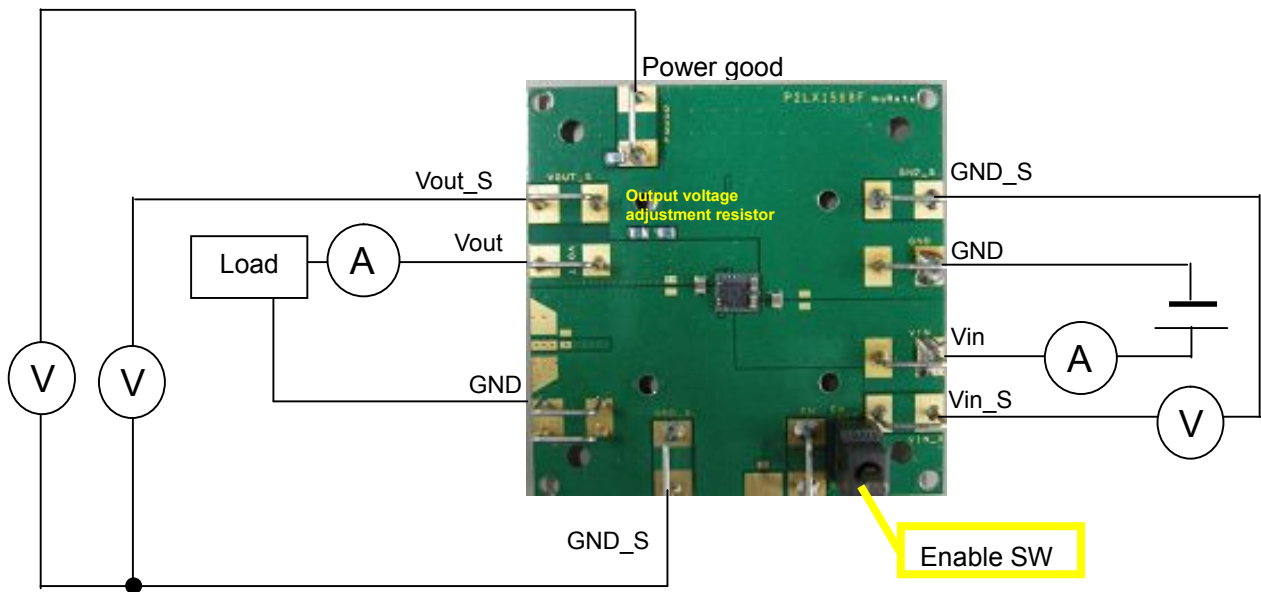

*** Evaluation board initial output Voltage setting : 3.3V (resistor : 560Ω + 16Ω)**

Efficiency

Vin=5.0V,

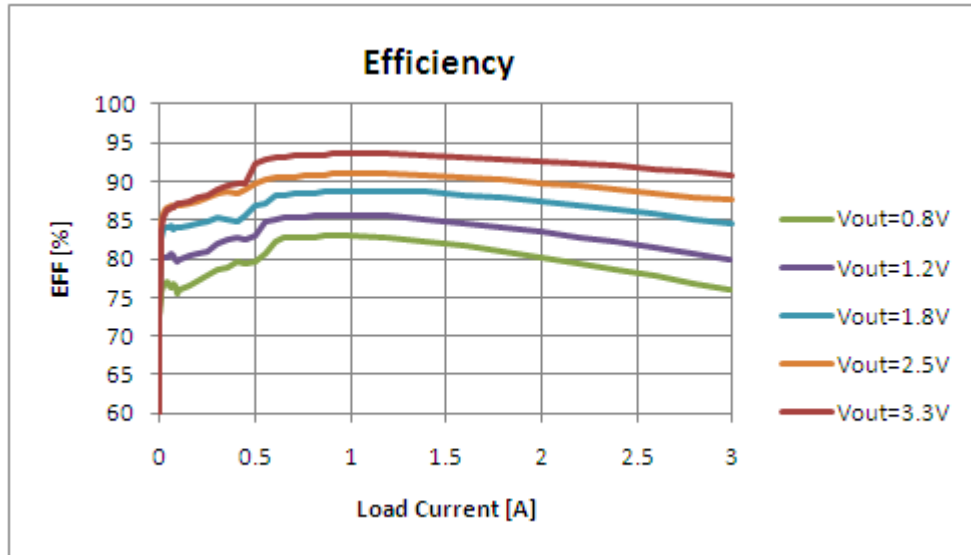

Output Ripple-Noise

Vin=5.0V, BW : 100MHz

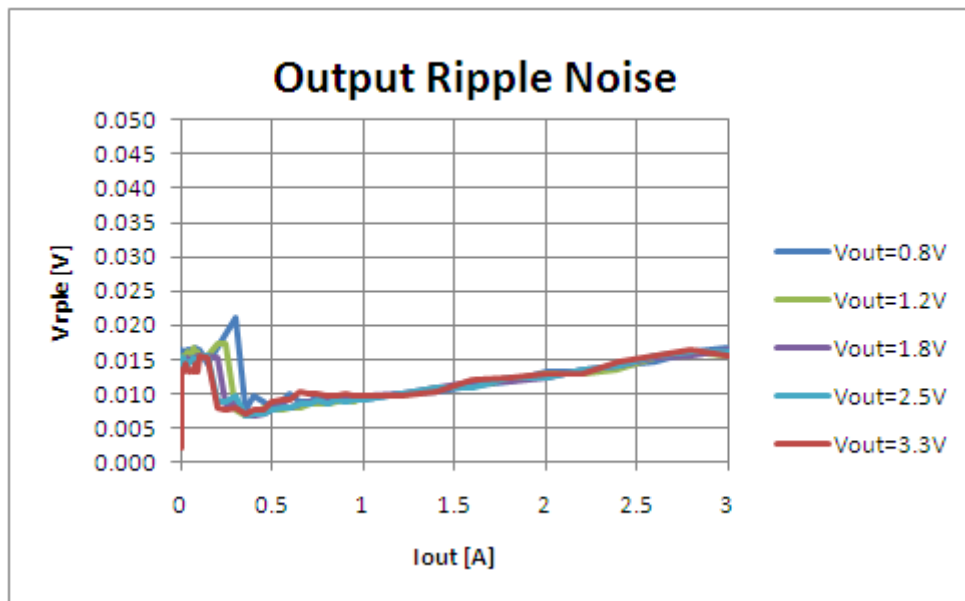

Load Regulation

Vin=5.0V, Vout=0.8V

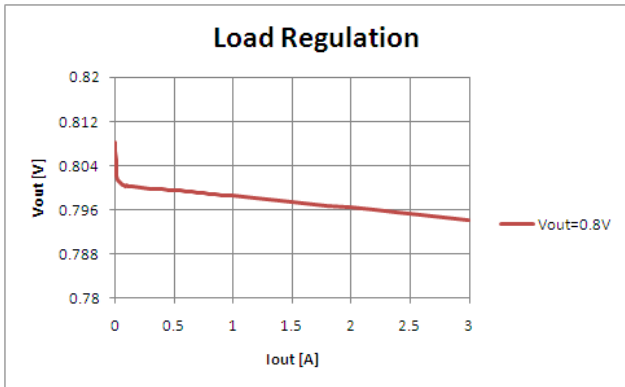

Vin=5.0V, Vout=1.2V

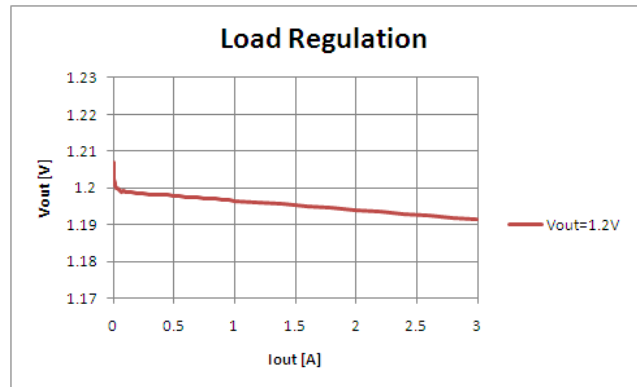

Vin=5.0V, Vout=1.8V

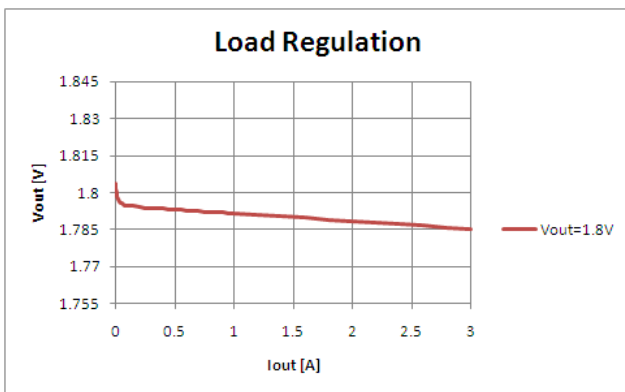

Vin=5.0V, Vout=2.5V

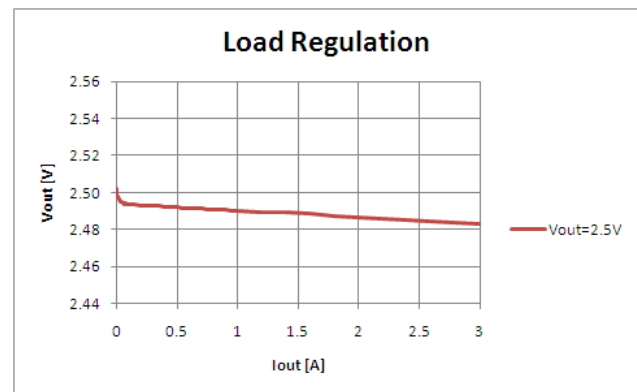

Vin=5.0V, Vout=3.3V

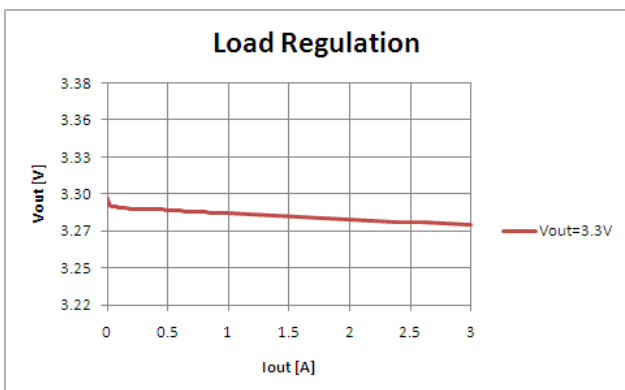

Note:

1. This datasheet's specifications are subject to change or our products in it may be discontinued without advance notice. Please check with our sales representatives or product engineers before ordering.
2. This datasheet has only typical specifications because there is no space for detailed specifications. Therefore, please approve our product specifications or transact the approval sheet for product specifications before ordering.