

LED DISPLAY**LTS-4817CKR-P**
DATA SHEET

<u>ITEM</u>	<u>Description</u>	<u>By</u>	<u>DATE</u>
1	New Spec	Reo Lin	2011/03/18
2	Modify PACKAGE DIMENSIONS AND RECOMMENDED SOLDERING PATTERN	Reo Lin	2011/08/11

FEATURES

- * 0.39 inch (10.0 mm) DIGIT HEIGHT
- * CONTINUOUS UNIFORM SEGMENTS
- * LOW POWER REQUIREMENT
- * EXCELLENT CHARACTERS APPEARANCE
- * HIGH BRIGHTNESS & HIGH CONTRAST
- * WIDE VIEWING ANGLE
- * SOLID STATE RELIABILITY
- * CATEGORIZED FOR LUMINOUS INTENSITY
- * SMD DISPLAY
- * **LEAD FREE PACKAGE (ACCORDING TO ROHS)**

DESCRIPTION

The LTS-4817CKR-P is a 0.39 inch (10.0 mm) digit height single digit SMD display. This device uses AS-AllnGaP SUPER RED LED chips (AllnGaP epi on GaAs substrate). The display has gray face and white segments, and suitable for reverse mount assembly.

DEVICE

PART NO.	DESCRIPTION
AllnGaP RED	Common Anode
LTS-4817CKR-P	

PACKAGE DIMENSIONS

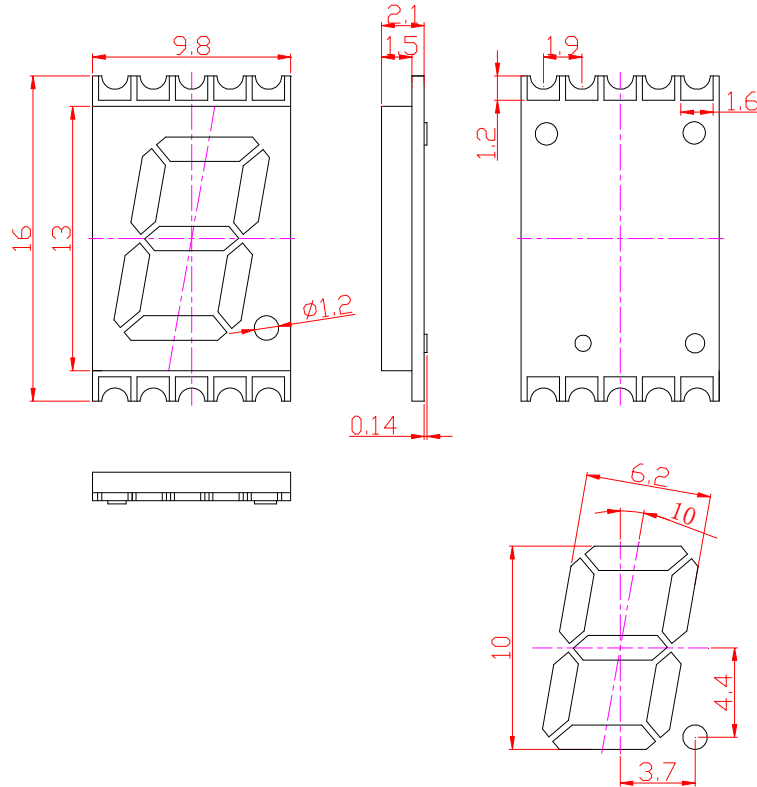

Solder Pad Vs Painting Diagram

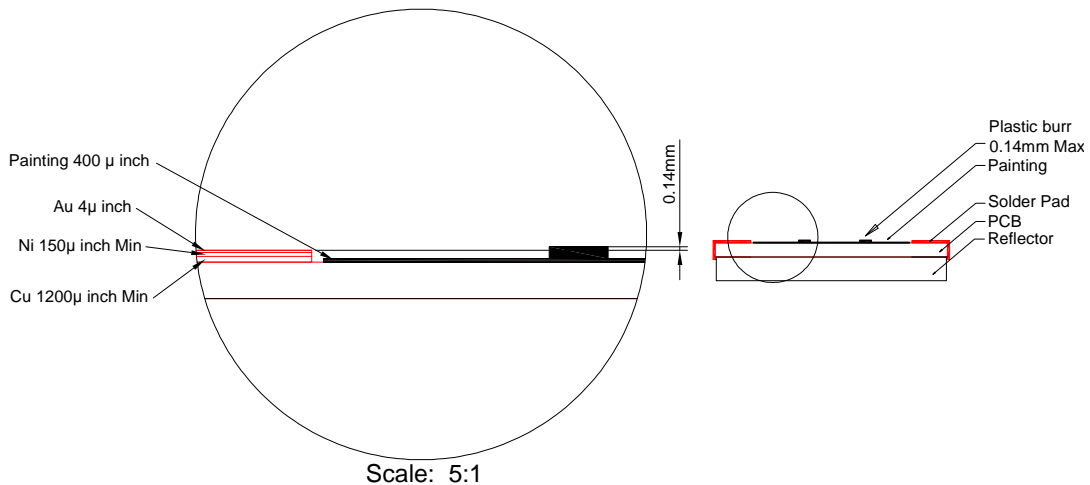

NOTES:

1. Plastic pins' burr max. 0.14 mm,
2. All dimensions are in millimeters. Tolerances are $\pm 0.25\text{mm}$ (0.01") unless otherwise noted.
3. Solder pad materials and thickness: Cu: 1200 μ inch Ni: Min 150 μ inch Au: 4 μ inch.

INTERNAL CIRCUIT DIAGRAM

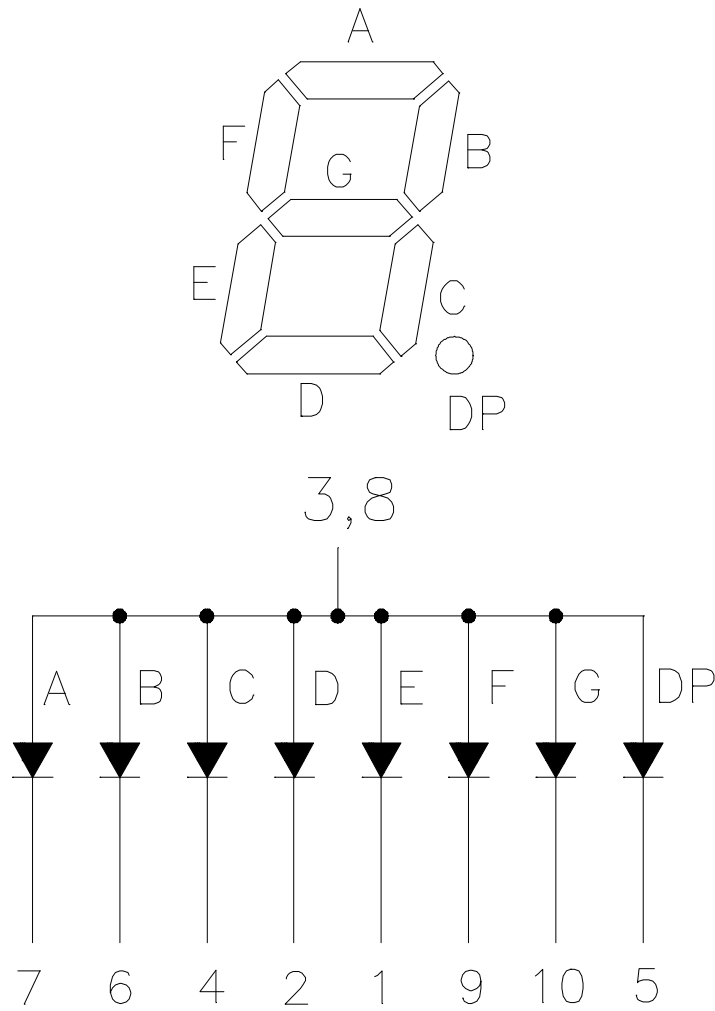

PIN CONNECTION

No.	CONNECTION
1	CATHODE E
2	CATHODE D
3	COMMON ANODE
4	CATHODE C
5	CATHODE D.P.
6	CATHODE B
7	CATHODE A
8	COMMON ANODE
9	CATHODE F
10	CATHODE G

ABSOLUTE MAXIMUM RATING AT Ta = 25°C

PARAMETER	MAXIMUM RATING	UNIT
Power Dissipation Per Segment	70	mW
Peak Forward Current Per Segment (Frequency 1Khz,10% duty cycle)	90	mA
Continuous Forward Current Per Segment	25	mA
Forward Current Derating from 25°C	0.27	mA/°C
Operating Temperature Range	-40°C to +105°C	
Storage Temperature Range	-40°C to +105°C	
Iron Soldering Conditions: 1/16 inch Below Seating Plane for 3 Seconds at 260°C		

ELECTRICAL / OPTICAL CHARACTERISTICS AT Ta = 25°C

PARAMETER	SYMBOL	MIN.	TYP.	MAX.	UNIT	TEST CONDITION
Average Luminous Intensity	I _v	1301	4900	8600	μ cd	I _F =2mA
Peak Emission Wavelength	λ _p		639		nm	I _F =2mA
Spectral Line Half-Width	Δλ		20		nm	I _F =2mA
Dominant Wavelength	λ _d		631		nm	I _F =2mA
Forward Voltage Per Segment	V _F		2.05	2.6	V	I _F =20mA
Reverse Current Per Segment ⁽²⁾	I _R			100	uA	V _R =5V
Luminous Intensity Matching Ratio	I _v -m			2:1		I _F =2mA

Note:

- Luminous intensity is measured with a light sensor and filter combination that approximates the CIE (Commision Internationale De L'Eclairage) eye-response curve.
- Reverse voltage is only for IR test. It can not continue to operate at this situation.

LUMINOUS INTENSITY BIN SELECTIONS: IF=2mA (Unit: ucd)

(Only one BIN for each reel)

Luminous Intensity		Unit : μ cd @2mA
Rank	Min.	Max.
J1	1301	1650
J2	1651	2100
K1	2101	2680
K2	2681	3400
L1	3401	4300
L2	4301	5400
M1	5401	6850
M2	6851	8600

Tolerance on each Intensity bin is +/-15%

TYPICAL ELECTRICAL / OPTICAL CHARACTERISTIC CURVES

(25°C Ambient Temperature Unless Otherwise Noted)

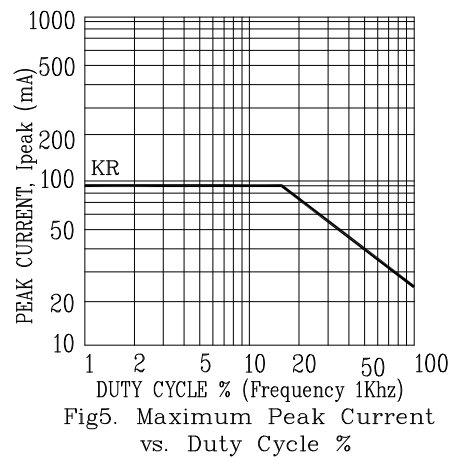
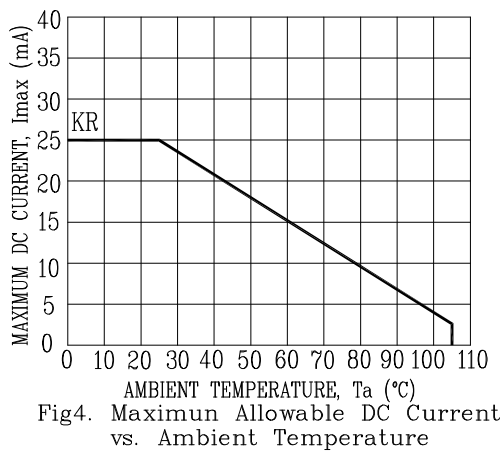
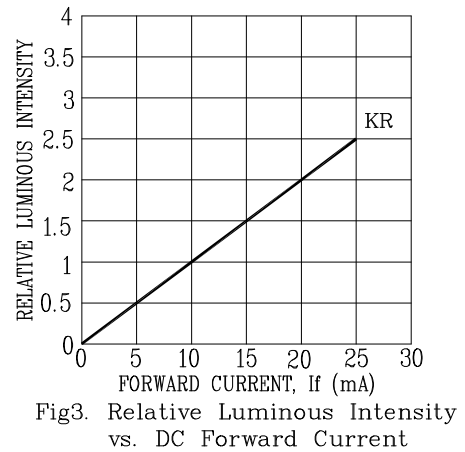
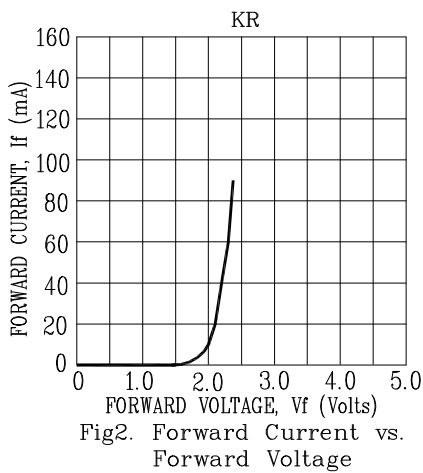
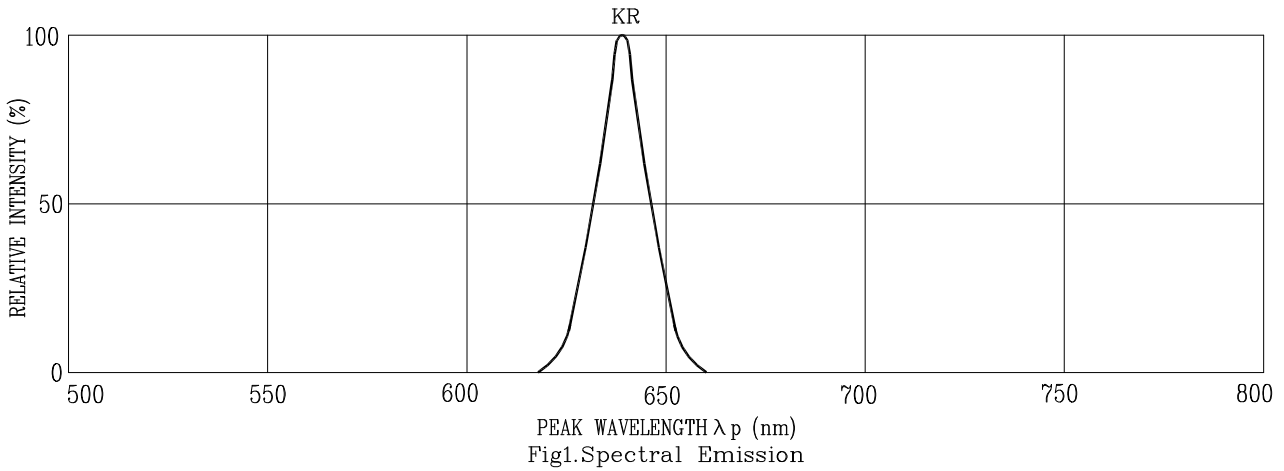

SMT SOLDERING INSTRUCTION

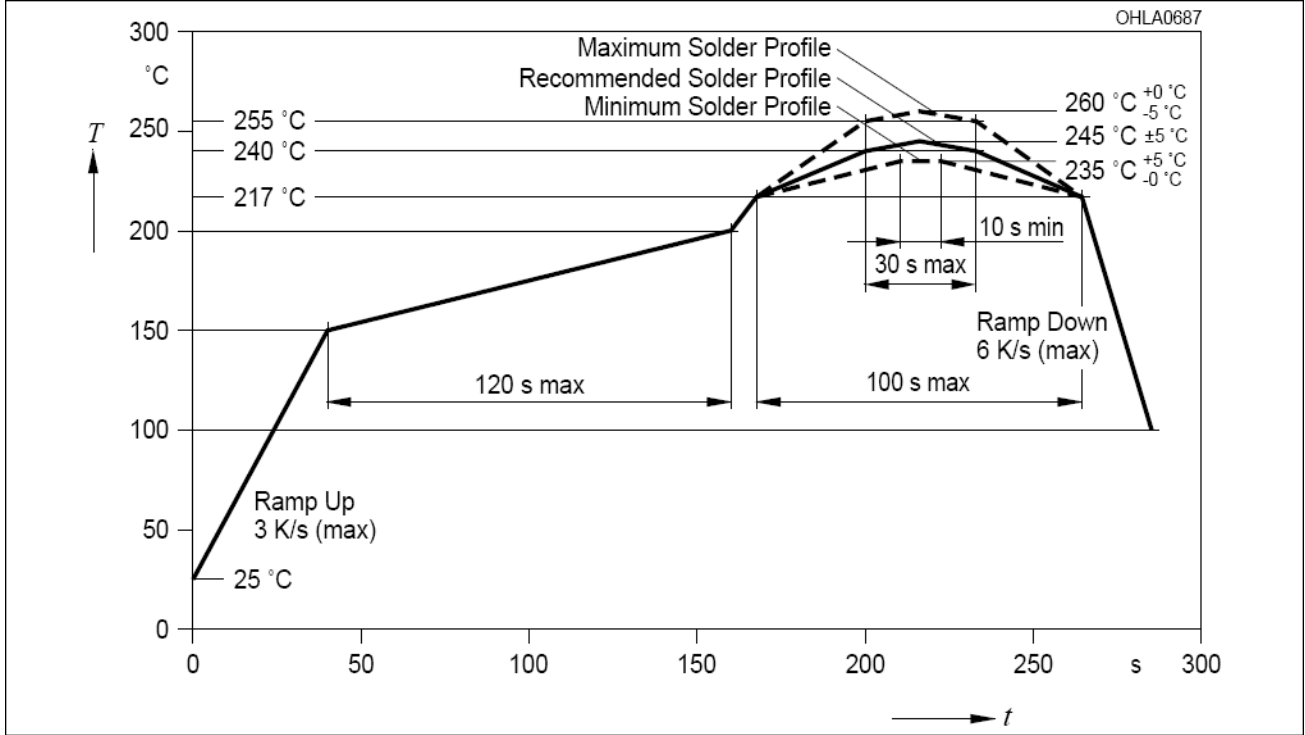

Note:

1. Recommended soldering condition:

Reflow Soldering (Two times only)		Soldering Iron (One time only)	
Pre-heat:	120~150°C.	Temperature	300°C Max.
Pre-heat time:	120sec. Max.	Soldering time	3sec. Max.
Peak temperature:	260°C Max.		
Soldering time:	5sec. Max.		

2. Number of reflow process shall be less than 2 times, and cooling process to normal temperature is required between the first and the second soldering process.

RECOMMENDED SOLDERING PATTERN

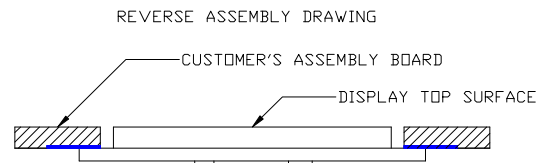
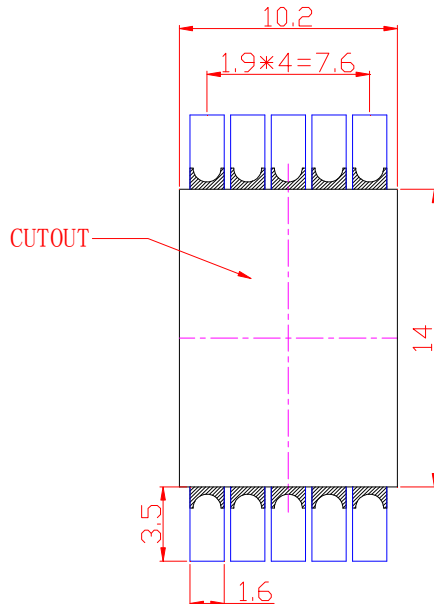

Note: All dimensions are in millimeters.

PACKING REEL DIMENSIONS

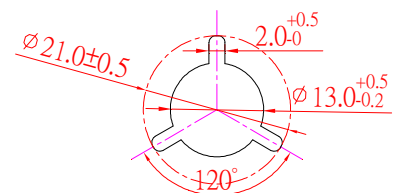
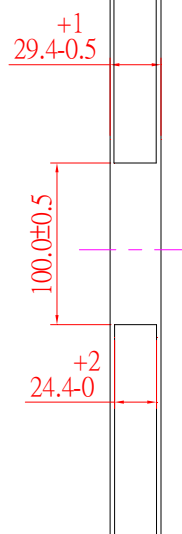
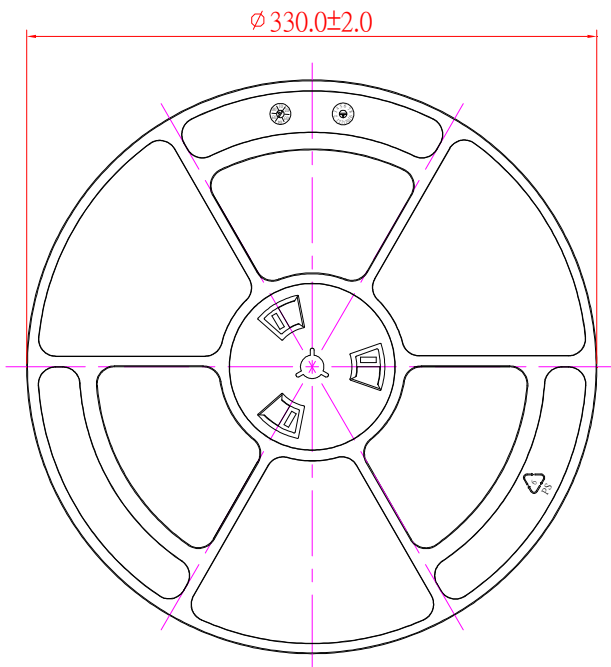

Moisture Proof Packaging

All N/D SMD displays are shipped in moisture proof package. The displays should be stored at 30°C or less and 90% RH or less. Once the package opened, moisture absorption begins.

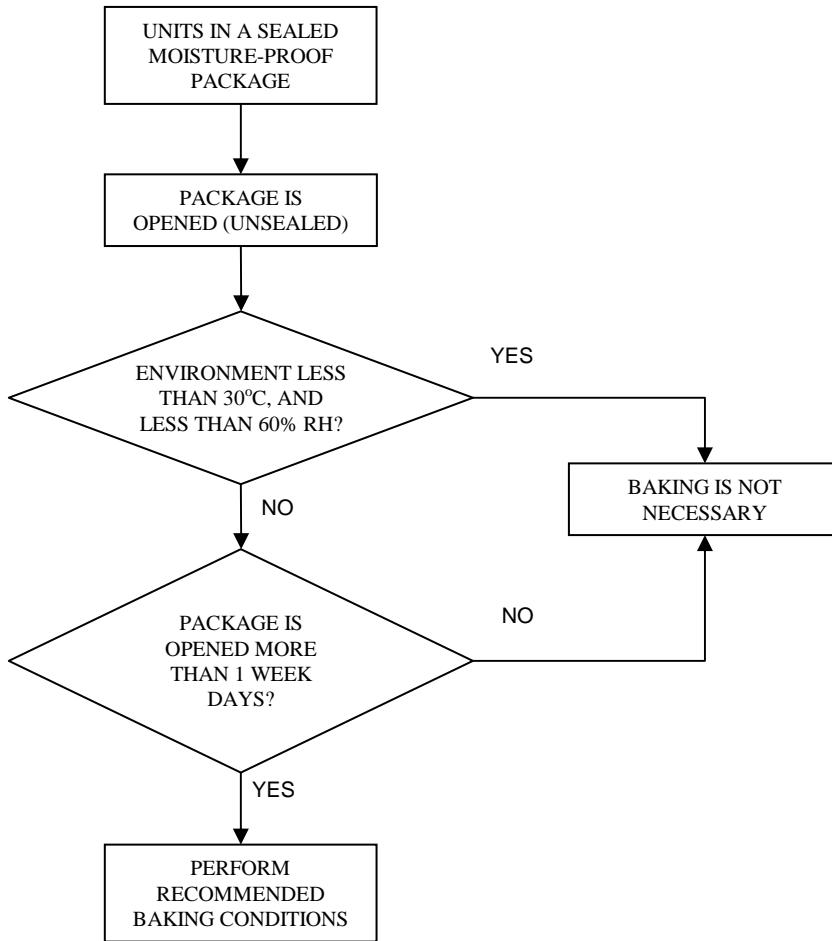

Baking Conditions

If the parts are not stored in dry conditions, they must be baked before reflow to prevent damage to the parts.

Package	Temperature	Time
In Reel	60 °C	≥ 48hours
In Bulk	100 °C	≥ 4hours
	125 °C	≥ 2hours

Baking should only be done once.