

## Features

- \* Designed for ease in circuit board assembly.
- \* Solid state light source.
- \* Pre-trimmed leads for PC Board mounting.
- \* Reliable and rugged.
- \* Black case enhance contrast ratio.
- \* Holder material: PC.

## Package Dimensions

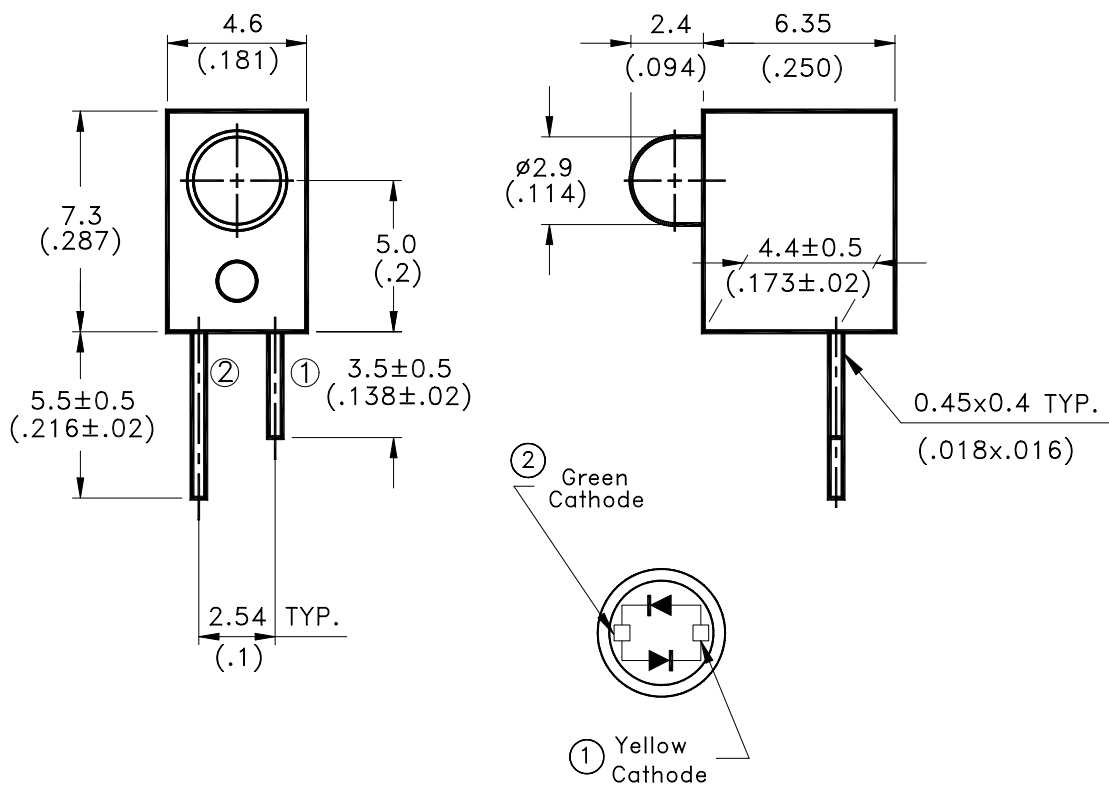

Lamp Part No.	Lens	Source Color
LTL-14CDJN	White Diffused	Yellow / Green

### Notes:

1. All dimensions are in millimeters (inches).
2. Tolerance is ±0.25mm(.010") unless otherwise noted.
3. Lead spacing is measured where the leads emerge from the package.
4. Specifications are subject to change without notice.

**Absolute Maximum Ratings at  $T_A=25^{\circ}\text{C}$** 

Parameter	Yellow	Green	Unit
Power Dissipation	60	100	mW
Peak Forward Current (1/10 Duty Cycle, 0.1ms Pulse Width)	60	90	mA
DC Forward Current	20	30	mA
Derating Linear From $50^{\circ}\text{C}$	0.25	0.4	mA/ $^{\circ}\text{C}$
Operating Temperature Range	$-55^{\circ}\text{C}$ to $+100^{\circ}\text{C}$		
Storage Temperature Range	$-55^{\circ}\text{C}$ to $+100^{\circ}\text{C}$		
Lead Soldering Temperature [1.6mm(.063") From Body]	$260^{\circ}\text{C}$ for 5 Seconds		

## Electrical / Optical Characteristics at T<sub>A</sub>=25°C

Parameter	Symbol	Color	Min.	Typ.	Max.	Unit	Test Condition
Luminous Intensity	I <sub>v</sub>	Yellow Green	2.5 3.7	8.7 12.6		mcd	I <sub>F</sub> = 20mA I <sub>F</sub> = 20mA Note 1,4
Viewing Angle	2θ <sub>1/2</sub>	Yellow Green		80 80		deg	Note 2 (Fig.6)
Peak Emission Wavelength	λ <sub>p</sub>	Yellow Green		585 565		nm	Measurement @Peak (Fig.1)
Dominant Wavelength	λ <sub>d</sub>	Yellow Green		588 569		nm	Note 3
Spectral Line Half-Width	Δλ	Yellow Green		35 30		nm	
Forward Voltage	V <sub>F</sub>	Yellow Green		2.1 2.1	2.6 2.6	V	I <sub>F</sub> = 20mA
Reverse Current	I <sub>R</sub>	Yellow Green			100	μA	V <sub>R</sub> = 5V Note 5
Capacitance	C	Yellow Green		15 35		pF	V <sub>F</sub> = 0, f = 1MHz

- Note: 1. Luminous intensity is measured with a light sensor and filter combination that approximates the CIE (Commission International De L'Eclairage) eye-response curve.
2. θ<sub>1/2</sub> is the off-axis angle at which the luminous intensity is half the axial luminous intensity.
3. The dominant wavelength, λ<sub>d</sub> is derived from the CIE chromaticity diagram and represents the single wavelength which defines the color of the device.
4. The I<sub>v</sub> guarantee should be added ±15%.
5. Reverse current is controlled by dice source.

Property of Lite-On Only

## Typical Electrical / Optical Characteristics Curves

(25°C Ambient Temperature Unless Otherwise Noted)

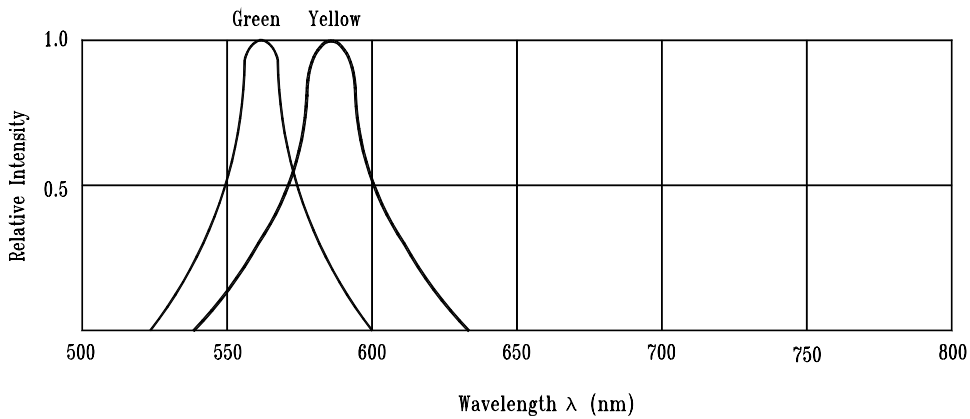

Fig.1 Relative Intensity vs. Wavelength

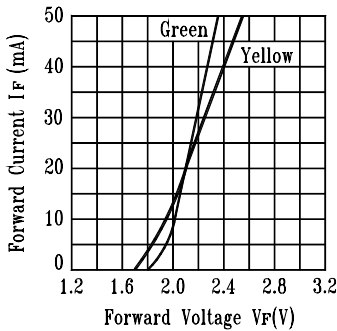

Fig.2 Forward Current vs. Forward Voltage

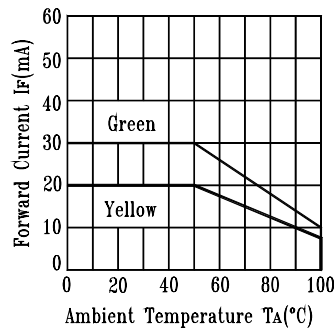

Fig.3 Forward Current Derating Curve

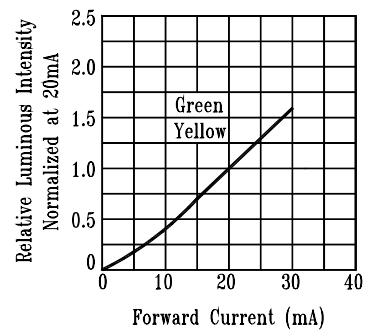

Fig.4 Relative Luminous Intensity vs. Forward Current

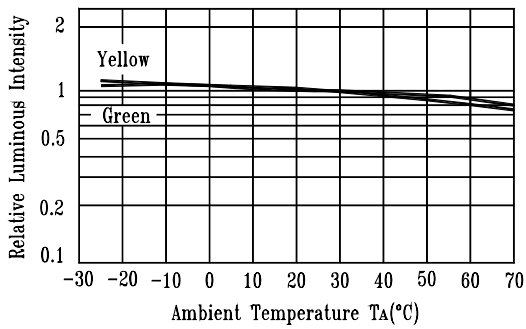

Fig.5 Luminous Intensity vs. Ambient Temperature

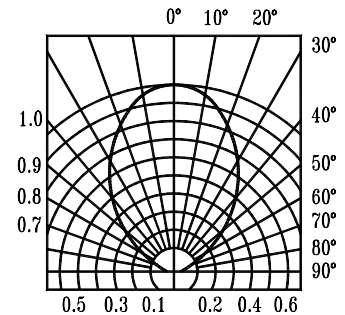

Fig.6 Spatial Distribution

## CAUTIONS

### 1. Application

The LEDs described here are intended to be used for ordinary electronic equipment (such as office equipment, communication equipment and household applications). Consult Liteon's Sales in advance for information on applications in which exceptional reliability is required, particularly when the failure or malfunction of the LEDs may directly jeopardize life or health (such as in aviation, transportation, traffic control equipment, medical and life support systems and safety devices).

### 2. Storage

The storage ambient for the LEDs should not exceed 30°C temperature or 70% relative humidity. It is recommended that LEDs out of their original packaging are used within three months.

For extended storage out of their original packaging, it is recommended that the LEDs be stored in a sealed container with appropriate desiccant or in a dessicator with nitrogen ambient.

### 3. Cleaning

Use alcohol-based cleaning solvents such as isopropyl alcohol to clean the LEDs if necessary.

### 4. Lead Forming & Assembly

During lead forming, the leads should be bent at a point at least 3mm from the base of LED lens. Do not use the base of the leadframe as a fulcrum during forming. Lead forming must be done before soldering at normal temperature. During assembly on PCB, use minimum clinch force possible to avoid excessive mechanical stress

### 5. Soldering

When soldering, leave a minimum of 2mm clearance from the base of the lens to the soldering point.

Dipping the lens into the solder must be avoided.

Do not apply any external stress to the lead frame during soldering while the LED is at high temperature.

Recommended soldering condition (for Lamp):

Soldering iron		Wave soldering	
Temperature	300°C Max.	Pre-heat	100°C Max.
Soldering time	3 sec. Max. (one time only)	Pre-heat time	60 sec. Max.
		Solder wave	260°C Max.
		Soldering time	10 sec. Max.

Note: Excessive soldering temperature and/or time might result in deformation of the LED lens or catastrophic failure of the LED.

### 6. Drive Method

An LED is a current operated device, In order to ensure intensity uniformity on multiple LEDs connected in parallel in an application; it is recommended that a current limiting resistor be incorporated in the drive circuit. In series with each LED as shown in Circuit A below.

**Circuit model A**

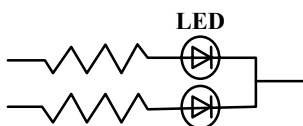

**Circuit model B**

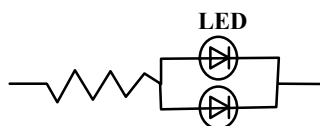

(A) Recommended circuit.

(B) The brightness of each LED might appear different due to the differences in the I-V characteristics of those LEDs

**7. ESD (Electrostatic Discharge)**

Static Electricity or power surge will damage the LED.

Suggestions to prevent ESD damage.

- Use a conductive wrist band or anti-electrostatic glove when handling these LEDs.
- All devices , equipment , and machinery must be properly grounded.
- Work tables , storage racks , etc. should be properly grounded .
- Use ion blower to neutralize the static charge which might have built up on surface of the LED's plastic lens as a result of friction between LEDs during storage and handling.

ESD-damaged LEDs will exhibit abnormal characteristics such as high reverse leakage current, low forward voltage, or “no lightup” at low currents. To verify for ESD damage, check for “lightup” and Vf of the suspect LEDs at low currents.

Suggested checking list :

**Training and Certification**

1. Everyone working in a static-safe area is ESD-certified?
2. Training records kept and re-certification dates monitored?

**Static-Safe Workstation & Work Areas**

1. Static-safe workstation or work-areas have ESD signs?
2. All surfaces and objects at all static-safe workstation and within 1 ft measure less than 100V?
3. All ionize activated, positioned towards the units?
4. Each work surface mats grounding is good?

**Personnel Grounding**

1. Every person (including visitors) handling ESD sensitive (ESDS) items wears wrist strap, heel strap or conductive shoes with conductive flooring?
2. If conductive footwear used, conductive flooring also present where operator stand or walk?
3. Garments, hairs or anything closer than 1 ft to ESD items measure less than 100V\*?
4. Every wrist strap or heel strap/conductive shoes checked daily and result recorded for all DLs?
5. All wrist strap or heel strap checkers calibration up to date?

Note: \*50V for Blue LED.

**Device Handling**

1. Every ESDS items identified by EIA-471 labels on item or packaging?
2. All ESDS items completely inside properly closed static-shielding containers when not at static-safe workstation?
3. No static charge generators (e.g. plastics) inside shielding containers with ESDS items?
4. All flexible conductive and dissipative package materials inspected before reuse or recycles?

**Others**

1. Audit result reported to entity ESD control coordinator?
2. Corrective action from previous audits completed?
3. Are audit records complete and on file?

## 8. Reliability Test

Classification	Test Item	Test Condition	Reference Standard
Endurance Test	Operation Life	Ta = Under room temperature as per data sheet maximum rating *Test time = 1000hrs (-24hrs, +72hrs)	MIL-STD-750D : 1026 (1995) MIL-STD-883D : 1005 (1991) JIS C 7021 : B-1 (1982)
	High Temperature High Humidity Storage	Ta = 65±5°C RH = 90 ~ 95% Test time = 240hrs±2hrs	MIL-STD-202F: 103B(1980) JIS C 7021 : B-11(1982)
	High Temperature High Humidity Reverse Bias	Ta = 65±5°C RH = 90 ~ 95% VR = 5V Test time = 500hrs (-24hrs, +48hrs)	JIS C 7021 : B-11(1982)
	High Temperature Storage	Ta = 105±5°C Test time = 1000hrs (-24hrs, +72hrs)	MIL-STD-883D : 1008 (1991) JIS C 7021 : B-10 (1982)
	Low Temperature Storage	Ta = -55±5°C Test time = 1000hrs (-24hrs, +72hrs)	JIS C 7021 : B-12 (1982)
	Environmental Test	Temperature Cycling	105°C ~ 25°C ~ -55°C ~ 25°C 30mins 5mins 30mins 5mins 10 cycles
Thermal Shock		105 ± 5°C ~ -55°C ± 5°C 10mins 10mins 10 cycles	MIL-STD-202F : 107D(1980) MIL-STD-750D : 1051(1995) MIL-STD-883D : 1011 (1991)
Solder Resistance		T.sol = 260 ± 5°C Dwell time = 10 ± 1secs	MIL-STD-202F : 210A(1980) MIL-STD-750D : 2031(1995) JIS C 7021 : A-1(1982)
Solderability		T.sol = 230 ± 5°C Dwell time = 5 ± 1secs	MIL-STD-202F : 208D(1980) MIL-STD-750D : 2026(1995) MIL-STD-883D : 2003(1991) JIS C 7021 : A-2(1982)

## 9. Others

The appearance and specifications of the product may be modified for improvement, without prior notice