

DO NOT SCALE FROM THIS PRINT

DESIGNED & DIMENSIONED IN MILLIMETERS [INCHES]

LSHM-1XX-XX-X-RH-A-X-X-TR

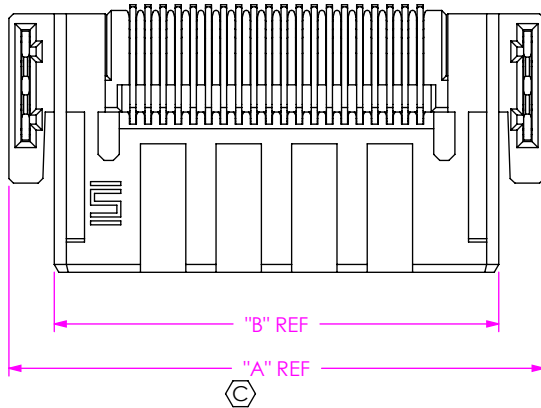

No OF POSITIONS  
-05, -10, -20, -30, -40, -50

LEAD STYLE  
-01: REVERSE RIGHT ANGLE  
-L1: LUBRICATED (SEE TABLE 2)

PACKAGING  
-TR: TAPE & REEL (SEE NOTE 5)  
OPTION  
-K: POLYAMIDE FILM (USE K-DOT-.177-.281-.005)

SHIELD  
-S: WITH SHIELD  
-N: WITHOUT SHIELD

PLATING SPECIFICATION  
-L: 10µ" SELECTIVE GOLD IN CONTACT AREA, MATTE TIN ON TAIL  
-F: 3µ" SELECTIVE GOLD IN CONTACT AREA, MATTE TIN ON TAIL  
-S: 30µ" SELECTIVE GOLD IN CONTACT AREA, MATTE TIN ON TAIL  
-H: 30µ" HEAVY GOLD IN CONTACT AREA, 3µ" GOLD ON TAIL

TAIL OPTION  
-RH: REVERSE RIGHT ANGLE

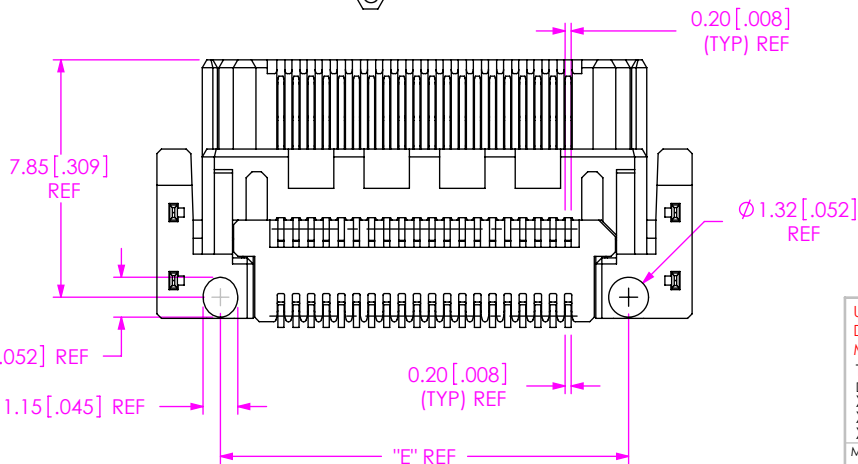
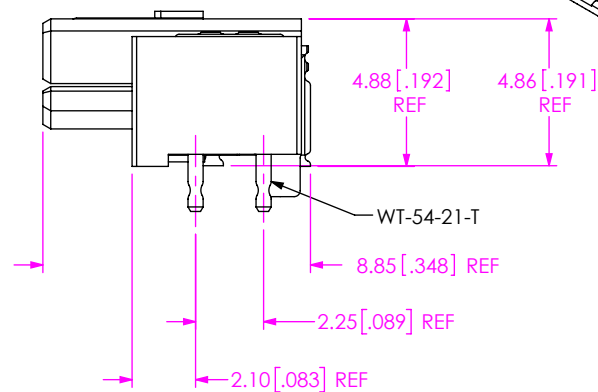
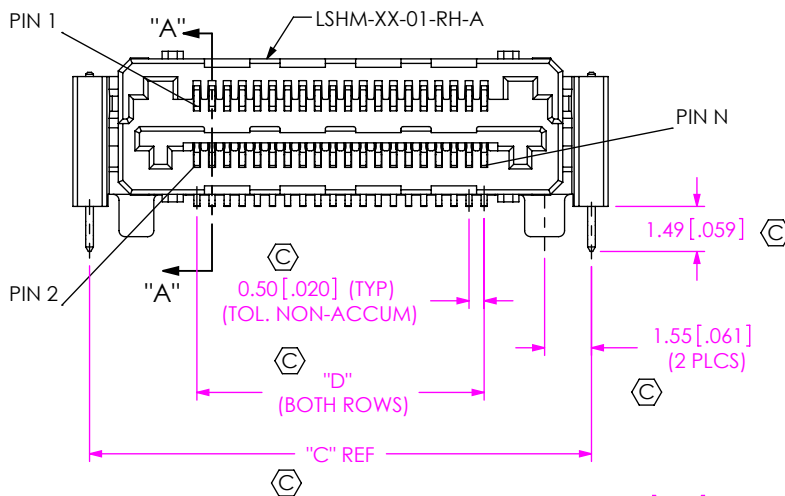
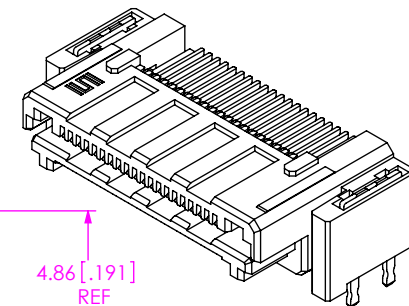

NOTES:

- ⊗ REPRESENTS A CRITICAL DIMENSION.
- BURR ALLOWANCE: .038 [.0015]
- MINIMUM PUSHOUT FORCE; TERMINALS: 2.22 N [.5 LBS], CONTACTS: 2.22 N [.5 LBS].
- NOTE DELETED.
- FOR QUANTITIES UP TO 49 PCS., NO LEADER, TRAILER OR REEL WILL BE SUPPLIED. FOR QUANTITIES OF 50-124 PCS., NO LEADER OR TRAILER WILL BE SUPPLIED.
- FOR APPLICATIONS REQUIRING TWO OR MORE CONNECTORS PER BOARD, CONTACT IPG@SAMTEC.COM.

FIG 1  
LSHM-120-X1-X-RH-A-N-X-XX SHOWN

UNLESS OTHERWISE SPECIFIED, DIMENSIONS ARE IN MILLIMETERS [INCHES].  
TOLERANCES ARE:  
DECIMALS X.X: ±0.3 [.01]  
X.XX: ±0.13 [.005]  
X.XXX: ±0.051 [.0020]

PROPRIETARY NOTE  
THIS DOCUMENT CONTAINS CONFIDENTIAL AND PROPRIETARY INFORMATION AND ALL DESIGN, MANUFACTURING, REPRODUCTION, USE, PATENT RIGHTS AND SALES RIGHTS ARE EXPRESSLY RESERVED BY SAMTEC, INC. THIS DOCUMENT SHALL NOT BE DISCLOSED, IN WHOLE OR PART, TO ANY UNAUTHORIZED PERSON OR ENTITY NOR REPRODUCED, TRANSFERRED OR INCORPORATED IN ANY OTHER PROJECT IN ANY MANNER WITHOUT THE EXPRESS WRITTEN CONSENT OF SAMTEC, INC.

MATERIAL: DO NOT SCALE DRAWING SHEET SCALE: 4:1  
INSULATOR: LCP, UL 94 VO, COLOR: BLACK  
TERMINAL: PHOS BRONZE  
SHIELD: STAINLESS STEEL  
WELD TAB: COPPER ALLOY



520 PARK EAST BLVD, NEW ALBANY, IN 47150  
PHONE: 812-944-6733 FAX: 812-948-5047  
e-Mail: info@SAMTEC.com code 53322

DESCRIPTION:  
0.5mm TERMINAL/SOCKET COMBO

DWG. NO.  
LSHM-1XX-XX-X-RH-A-X-X-TR

BY: VICKY Z 03/12/2011 SHEET 1 OF 4

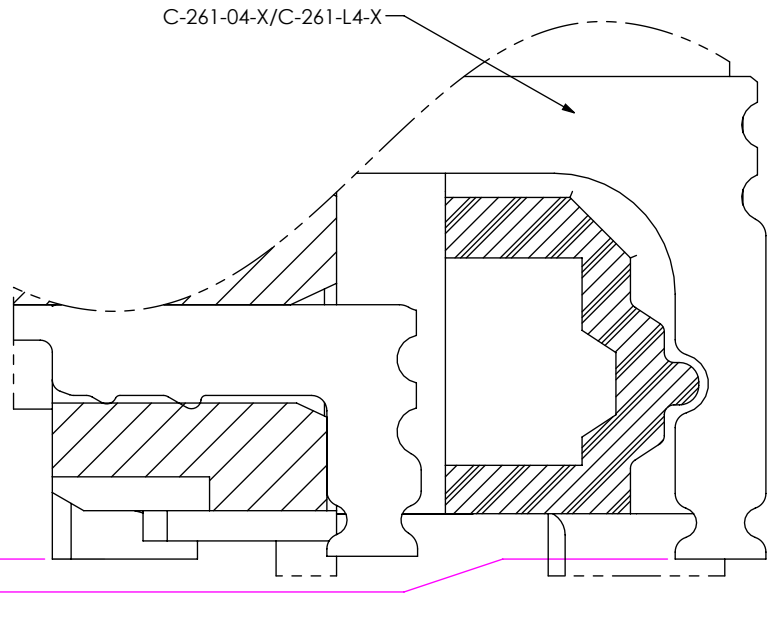
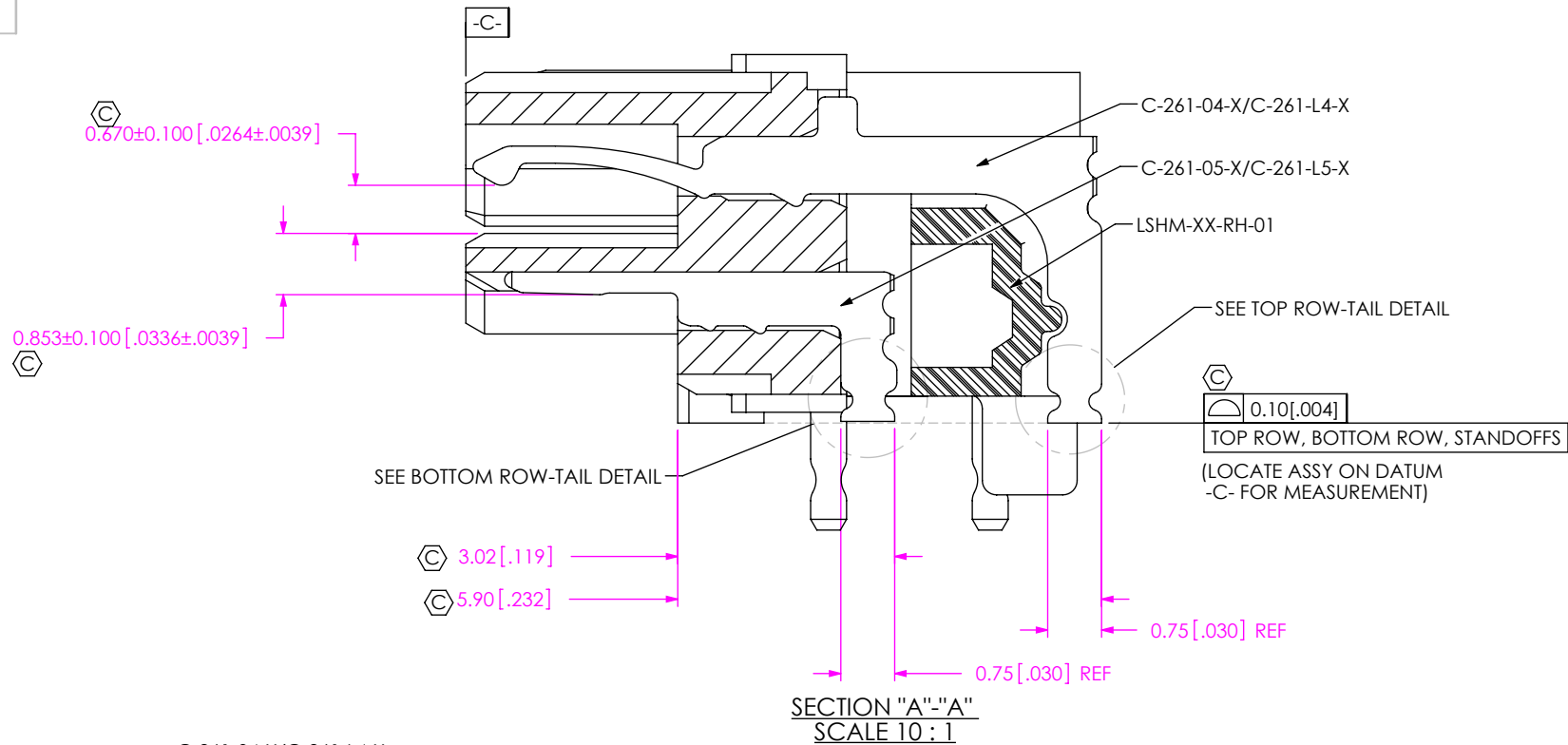

**TOP ROW-TAIL DETAIL**  
(LOCATE ASSY ON DATUM -C- FOR MEASUREMENT)

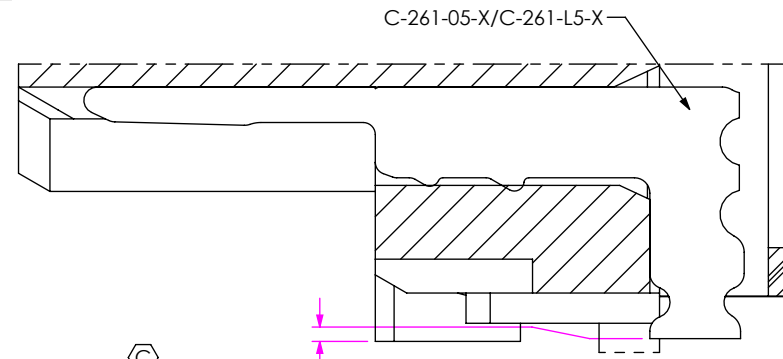

**BOTTOM ROW-TAIL DETAIL**  
(LOCATE ASSY ON DATUM -C- FOR MEASUREMENT)

F:\DWG\MISC\MKTG\LSHM-1XX-XX-X-RH-A-X-X-TR-MKT.SLDDRW

<p><b>PROPRIETARY NOTE</b></p> <p>THIS DOCUMENT CONTAINS CONFIDENTIAL AND PROPRIETARY INFORMATION AND ALL DESIGN, MANUFACTURING, REPRODUCTION, USE, PATENT RIGHTS AND SALES RIGHTS ARE EXPRESSLY RESERVED BY SAMTEC, INC. THIS DOCUMENT SHALL NOT BE DISCLOSED, IN WHOLE OR PART, TO ANY UNAUTHORIZED PERSON OR ENTITY NOR REPRODUCED, TRANSFERRED OR INCORPORATED IN ANY OTHER PROJECT IN ANY MANNER WITHOUT THE EXPRESS WRITTEN CONSENT OF SAMTEC, INC.</p> <p>DO NOT SCALE DRAWING</p> <p>SHEET SCALE: 4:1</p>		
	<p>520 PARK EAST BLVD, NEW ALBANY, IN 47150 PHONE: 812-944-6733 FAX: 812-948-5047 e-Mail info@SAMTEC.com code 55322</p>	
	<p>DESCRIPTION: <b>0.5mm TERMINAL/SOCKET COMBO</b></p>	
	<p>DWG. NO. <b>LSHM-1XX-XX-X-RH-A-X-X-TR</b></p>	
<p>BY: VICKY Z 03/12/2011</p>		<p>SHEET 2 OF 4</p>

TABLE 1								
No OF POS.	"A"	"B"	"C"	"D"	"E"	"F"	"G"	"H"
-05	10.20 [0.402]	7.20 [0.283]	9.10 [0.358]	2.00 [0.079]	6.00 [0.236]	7.25 [0.285]	5.15 [0.203]	7.36 [0.290]
-10	12.70 [0.500]	9.70 [0.382]	11.60 [0.457]	4.50 [0.177]	8.50 [0.335]	9.75 [0.384]	7.65 [0.301]	9.86 [0.388]
-20	17.70 [0.697]	14.70 [0.579]	16.60 [0.654]	9.50 [0.374]	13.50 [0.531]	14.75 [0.581]	12.65 [0.498]	14.86 [0.585]
-30	22.70 [0.894]	19.70 [0.776]	21.60 [0.850]	14.50 [0.571]	18.50 [0.728]	19.75 [0.778]	17.65 [0.695]	19.86 [0.782]
-40	27.70 [1.091]	24.70 [0.972]	26.60 [1.047]	19.50 [0.768]	23.50 [0.925]	24.75 [0.974]	22.65 [0.892]	24.86 [0.979]
-50	32.70 [1.287]	29.70 [1.169]	31.60 [1.244]	24.50 [0.965]	28.50 [1.122]	29.75 [1.171]	27.65 [1.089]	29.86 [1.176]

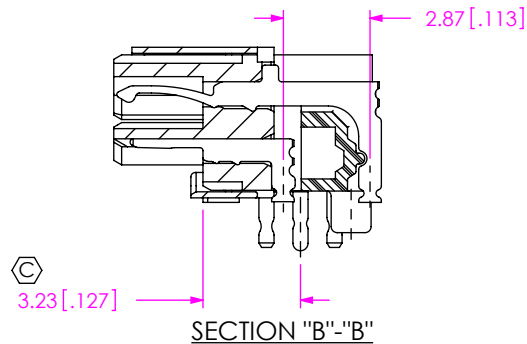
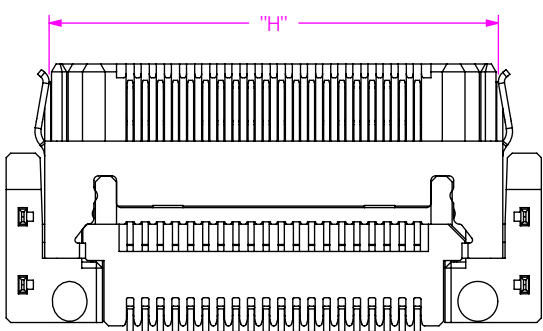
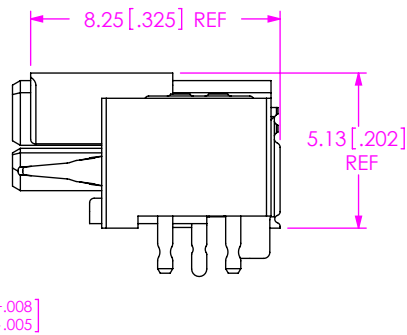
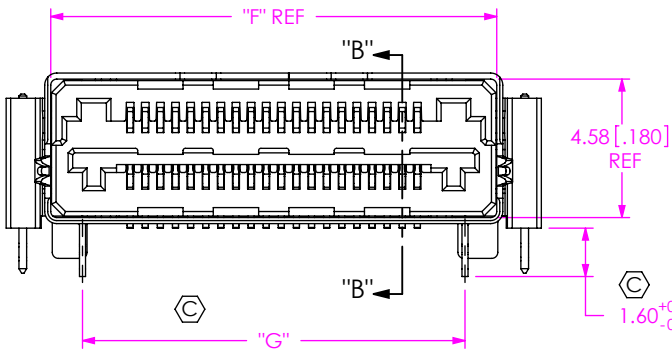
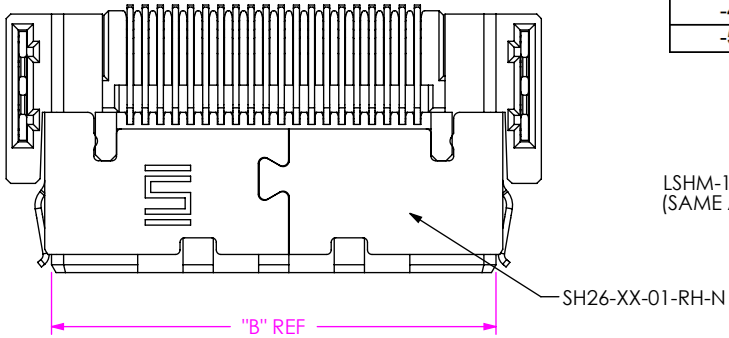
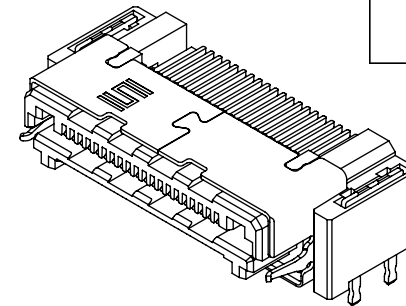

TABLE 2	
LEAD STYLE	CONTACT
-01	C-261-04-X
	C-261-05-X
-L1	C-261-L4-X
	C-261-L5-X



F:\DWG\MISC\MKTG\LSHM-1XX-XX-X-RH-A-X-X-TR-MKT.SLDDRW

**PROPRIETARY NOTE**  
THIS DOCUMENT CONTAINS CONFIDENTIAL AND PROPRIETARY INFORMATION AND ALL DESIGN, MANUFACTURING, REPRODUCTION, USE, PATENT RIGHTS AND SALES RIGHTS ARE EXPRESSLY RESERVED BY SAMTEC, INC. THIS DOCUMENT SHALL NOT BE DISCLOSED, IN WHOLE OR PART, TO ANY UNAUTHORIZED PERSON OR ENTITY NOR REPRODUCED, TRANSFERRED OR INCORPORATED IN ANY OTHER PROJECT IN ANY MANNER WITHOUT THE EXPRESS WRITTEN CONSENT OF SAMTEC, INC.

DO NOT SCALE DRAWING

SHEET SCALE: 4:1



520 PARK EAST BLVD, NEW ALBANY, IN 47150  
PHONE: 812-944-6733 FAX: 812-948-5047  
e-Mail info@SAMTEC.com code 55322

DESCRIPTION:  
0.5mm TERMINAL/SOCKET COMBO

DWG. NO.  
LSHM-1XX-XX-X-RH-A-X-X-TR

BY: VICKY Z 03/12/2011 SHEET 3 OF 4

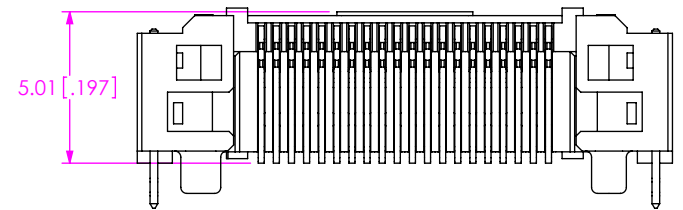
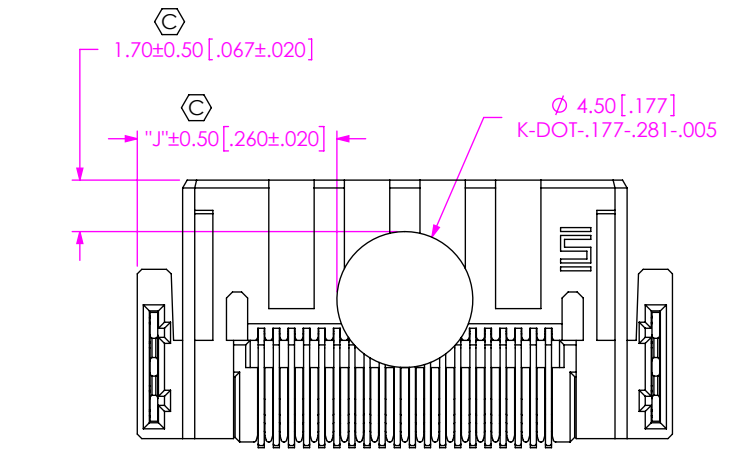
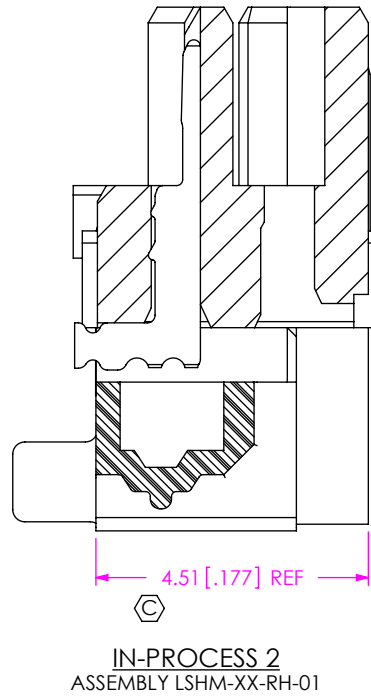
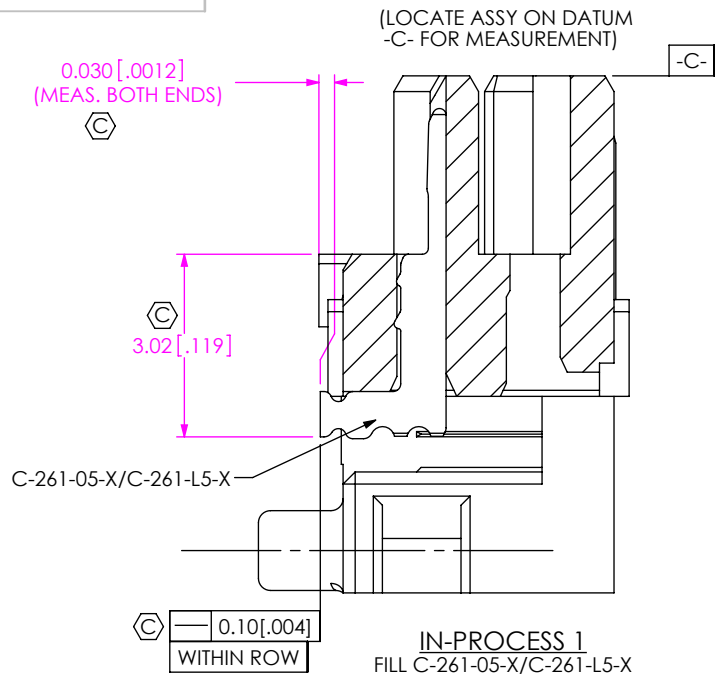
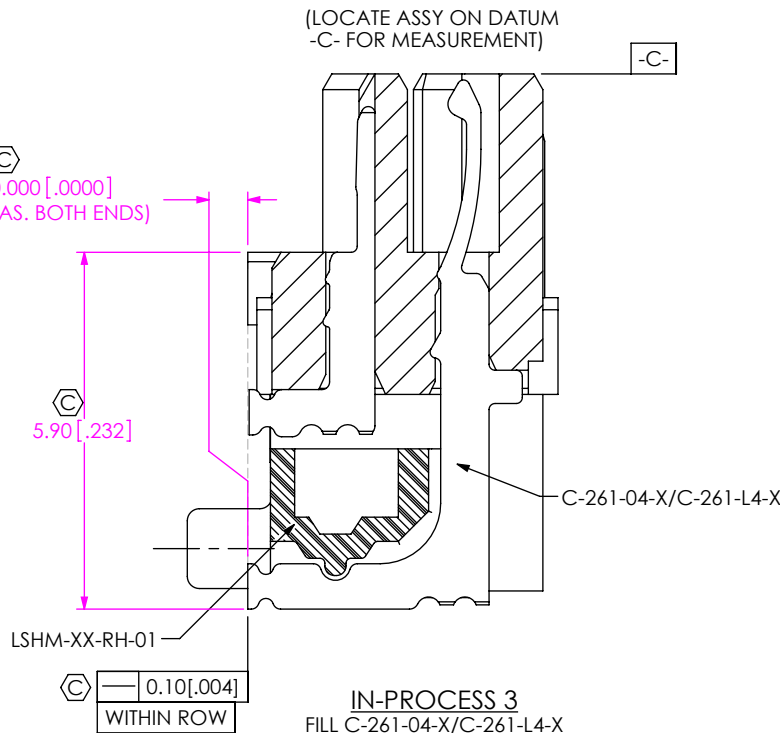

FIG 3  
LSHM-120-X1-X-RH-A-N-K-XX SHOWN

No OF POS.	"J"
-05	2.85 [0.112]
-10	4.10 [0.161]
-20	6.60 [0.260]
-30	9.10 [0.358]
-40	11.60 [0.457]
-50	14.10 [0.555]

F:\DWG\MISC\MKTG\LSHM-1XX-XX-X-RH-A-X-X-TR-MKT.SLDDRW



**PROPRIETARY NOTE**  
THIS DOCUMENT CONTAINS CONFIDENTIAL AND PROPRIETARY INFORMATION AND ALL DESIGN, MANUFACTURING, REPRODUCTION, USE, PATENT RIGHTS AND SALES RIGHTS ARE EXPRESSLY RESERVED BY SAMTEC, INC. THIS DOCUMENT SHALL NOT BE DISCLOSED, IN WHOLE OR PART, TO ANY UNAUTHORIZED PERSON OR ENTITY NOR REPRODUCED, TRANSFERRED OR INCORPORATED IN ANY OTHER PROJECT IN ANY MANNER WITHOUT THE EXPRESS WRITTEN CONSENT OF SAMTEC, INC.

DO NOT SCALE DRAWING  
SHEET SCALE: 4:1



520 PARK EAST BLVD. NEW ALBANY, IN 47150  
PHONE: 812-944-6733 FAX: 812-948-5047  
e-Mail info@SAMTEC.com code 55322

DESCRIPTION:  
0.5mm TERMINAL/SOCKET COMBO

DWG. NO.  
LSHM-1XX-XX-X-RH-A-X-X-TR

BY: VICKY Z 03/12/2011 SHEET 4 OF 4