

LMV321-Q1 SINGLE, LMV358-Q1 DUAL, LMV324-Q1 QUAD LOW-VOLTAGE RAIL-TO-RAIL OUTPUT OPERATIONAL AMPLIFIERS

SLOS415D – JUNE 2003 – REVISED OCTOBER 2004

- **Qualification in Accordance With AEC-Q100†**
- **Qualified for Automotive Applications**
- **Customer-Specific Configuration Control Can Be Supported Along With Major-Change Approval**
- **2.7-V and 5-V Performance**
- **No Crossover Distortion**
- **Low Supply Current:**
 LMV321 . . . 130 μ A Typ
 LMV358 . . . 210 μ A Typ
 LMV324 . . . 410 μ A Typ
- **Rail-to-Rail Output Swing**

†Contact factory for details. Q100 qualification data available on request.

description/ordering information

The LMV321, LMV358, and LMV324 are single, dual, and quad low-voltage (2.7 V to 5.5 V) operational amplifiers with rail-to-rail output swing.

The LMV321, LMV358, and LMV324 are the most cost-effective solution for applications where low-voltage operation, space saving, and low price are required. These amplifiers were designed specifically for low-voltage (2.7 V to 5 V) operation, with performance specifications meeting or exceeding the LM358 and LM324 devices that operate from 5 V to 30 V. Additional features of the LMV3xx devices are a common-mode input voltage range that includes ground, 1-MHz unity-gain bandwidth, and 1-V/ μ s slew rate.

LMV324 . . . D OR PW PACKAGE
(TOP VIEW)

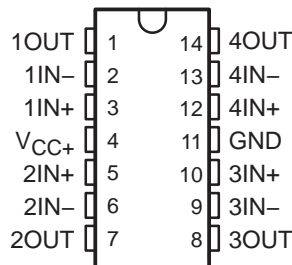

LMV358 . . . D OR PW PACKAGE
(TOP VIEW)

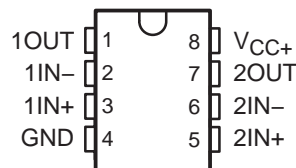

LMV321 . . . DBV PACKAGE
(TOP VIEW)

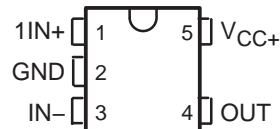

Please be aware that an important notice concerning availability, standard warranty, and use in critical applications of Texas Instruments semiconductor products and disclaimers thereto appears at the end of this data sheet.

PRODUCTION DATA information is current as of publication date. Products conform to specifications per the terms of Texas Instruments standard warranty. Production processing does not necessarily include testing of all parameters.

 **TEXAS
INSTRUMENTS**

POST OFFICE BOX 655303 • DALLAS, TEXAS 75265

Copyright © 2004, Texas Instruments Incorporated

LMV321-Q1 SINGLE, LMV358-Q1 DUAL, LMV324-Q1 QUAD LOW-VOLTAGE RAIL-TO-RAIL OUTPUT OPERATIONAL AMPLIFIERS

SLOS415D – JUNE 2003 – REVISED OCTOBER 2004

ORDERING INFORMATION

| T _A | | PACKAGE† | | ORDERABLE PART NUMBER | TOP-SIDE MARKING |
|----------------|--------|---------------|--------------|-----------------------|------------------|
| -40°C to 85°C | Single | SOT23-5 (DBV) | Reel of 3000 | LMV321IDBVRQ1 | RC1B |
| -40°C to 85°C | Dual | SOIC (D) | Tube of 75 | LMV358IDQ1 | 358IQ1 |
| | | | Reel of 2500 | LMV358IDRQ1 | |
| | | TSSOP (PW) | Reel of 2000 | LMV358IPWRQ1 | 358IQ1 |
| -40°C to 85°C | Quad | SOIC (D) | Tube of 50 | LMV324IDQ1 | LMV324IQ1 |
| | | | Reel of 2500 | LMV324IDRQ1 | |
| | | TSSOP (PW) | Reel of 2000 | LMV324IPWRQ1 | V324IQ1 |
| -40°C to 125°C | Single | SOT23-5 (DBV) | Reel of 3000 | LMV321QDBVRQ1 | RCCB |
| -40°C to 125°C | Dual | SOIC (D) | Tube of 75 | LMV358QDQ1 | V358Q1 |
| | | | Reel of 2500 | LMV358QDRQ1 | |
| | | TSSOP (PW) | Reel of 2000 | LMV358QPWRQ1 | V358Q1 |
| -40°C to 125°C | Quad | SOIC (D) | Tube of 50 | LMV324QDQ1 | LMV324Q1 |
| | | | Reel of 2500 | LMV324QDRQ1 | |
| | | TSSOP (PW) | Reel of 2000 | LMV324QPWRQ1 | MV324Q1 |

† Package drawings, standard packing quantities, thermal data, symbolization, and PCB design guidelines are available at www.ti.com/sc/package.

symbol (each amplifier)

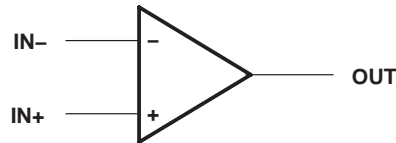

LMV321-Q1 SINGLE, LMV358-Q1 DUAL, LMV324-Q1 QUAD LOW-VOLTAGE RAIL-TO-RAIL OUTPUT OPERATIONAL AMPLIFIERS

SLOS415D – JUNE 2003 – REVISED OCTOBER 2004

LMV324 simplified schematic

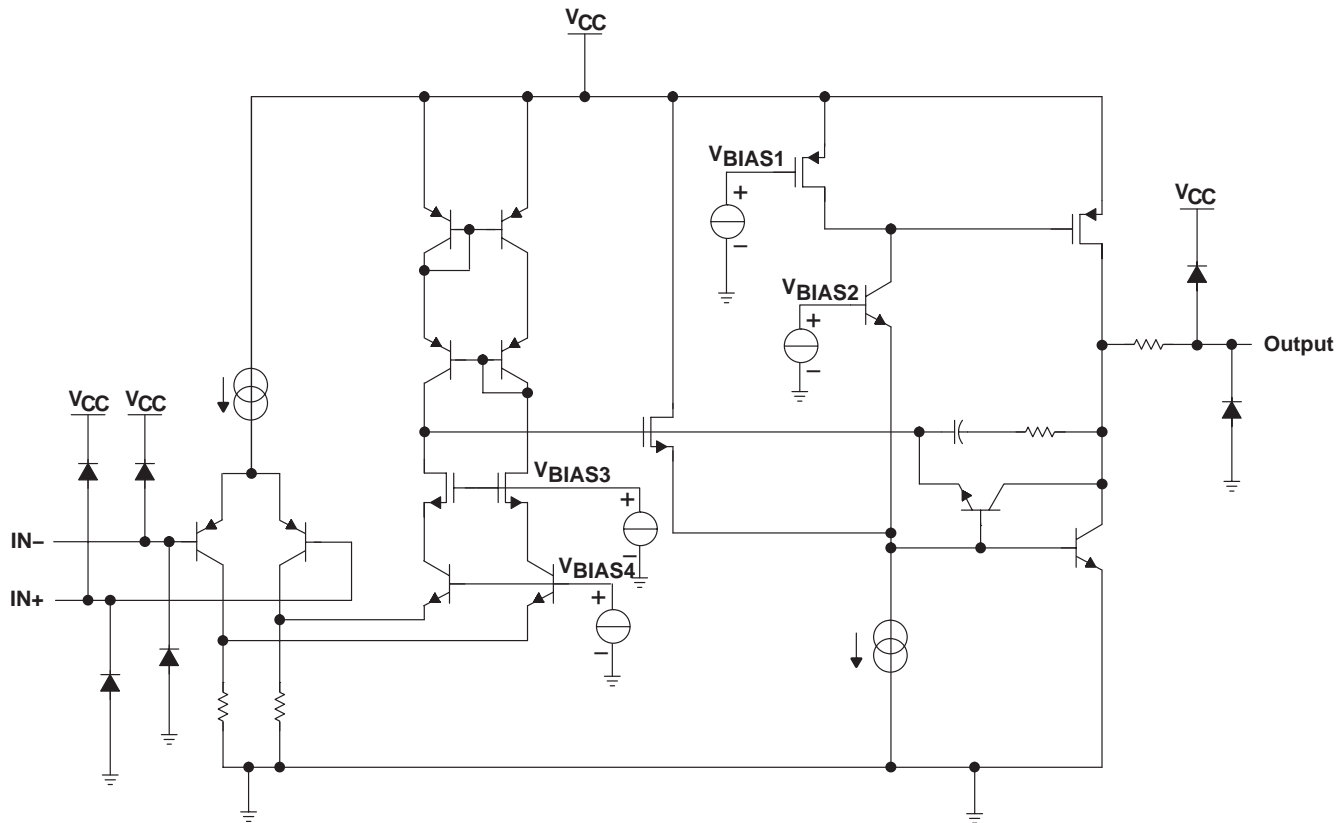

absolute maximum ratings over operating free-air temperature range (unless otherwise noted)†

| | |
|---|--------------|
| Supply voltage, V_{CC} (see Note 1) | 5.5 V |
| Differential input voltage, V_{ID} (see Note 2) | ± 5.5 V |
| Input voltage, V_I (either input) | 0 to 5.5 V |
| Duration of output short circuit (one amplifier) to ground at (or below) $T_A = 25^\circ\text{C}$, $V_{CC} \leq 5.5$ V (see Note 3) | Unlimited |
| Package thermal impedance, θ_{JA} (see Notes 4 and 5): | |
| D (8-pin) package | 97°C/W |
| D (14-pin) package | 86°C/W |
| DBV (5-pin) package | 206°C/W |
| PW (8-pin) package | 149°C/W |
| PW (14-pin) package | 113°C/W |
| Operating virtual junction temperature, T_J | 150°C |
| Storage temperature range, T_{stg} | -65 to 150°C |

† Stresses beyond those listed under “absolute maximum ratings” may cause permanent damage to the device. These are stress ratings only, and functional operation of the device at these or any other conditions beyond those indicated under “recommended operating conditions” is not implied. Exposure to absolute-maximum-rated conditions for extended periods may affect device reliability.

- NOTES:
1. All voltage values (except differential voltages and V_{CC} specified for the measurement of I_{OS}) are with respect to the network GND.
 2. Differential voltages are at IN+ with respect to IN-.
 3. Short circuits from outputs to V_{CC} can cause excessive heating and eventual destruction.
 4. Maximum power dissipation is a function of $T_J(\text{max})$, θ_{JA} , and T_A . The maximum allowable power dissipation at any allowable ambient temperature is $P_D = (T_J(\text{max}) - T_A)/\theta_{JA}$. Selecting the maximum of 150°C can affect reliability.
 5. The package thermal impedance is calculated in accordance with JESD 51-7.

LMV321-Q1 SINGLE, LMV358-Q1 DUAL, LMV324-Q1 QUAD LOW-VOLTAGE RAIL-TO-RAIL OUTPUT OPERATIONAL AMPLIFIERS

SLOS415D – JUNE 2003 – REVISED OCTOBER 2004

recommended operating conditions (see Note 6)

| | | MIN | MAX | UNIT | |
|-----------------|--|-------------------------|-----|------|----|
| V _{CC} | Supply voltage (single-supply operation) | 2.7 | 5.5 | V | |
| V _{IH} | Amplifier turn-on voltage level | V _{CC} = 2.7 V | 1.7 | V | |
| | | V _{CC} = 5 V | 3.5 | | |
| V _{IL} | Amplifier turn-off voltage level | V _{CC} = 2.7 V | 0.7 | V | |
| | | V _{CC} = 5 V | 1.5 | | |
| T _A | Operating free-air temperature | I suffix | -40 | 85 | °C |
| | | Q suffix | -40 | 125 | |

NOTE 6: All unused control inputs of the device must be held at V_{CC} or GND to ensure proper device operation. Refer to the TI application report, *Implications of Slow or Floating CMOS Inputs*, literature number SCBA004.

electrical characteristics at T_A = 25°C, V_{CC+} = 2.7 V (unless otherwise noted)

| PARAMETER | TEST CONDITIONS | | MIN | TYP | MAX | UNIT |
|-----------------------------|---|--|-----------------------|----------------------|-----|--------|
| V _{IO} | Input offset voltage | | | 1.7 | 7 | mV |
| α _{V_{IO}} | Average temperature coefficient of input offset voltage | | | 5 | | μV/°C |
| I _{IB} | Input bias current | | | 11 | 250 | nA |
| I _{IO} | Input offset current | | | 5 | 50 | nA |
| CMRR | Common-mode rejection ratio | V _{CM} = 0 to 1.7 V | 50 | 63 | | dB |
| k _{SVR} | Supply-voltage rejection ratio | V _{CC} = 2.7 V to 5 V, V _O = 1 V | 50 | 60 | | dB |
| V _{ICR} | Common-mode input voltage range | CMRR ≥ 50 dB | 0 to 1.7 | -0.2 to 1.9 | | V |
| Output swing | R _L = 10 kΩ to 1.35 V | High level | V _{CC} - 100 | V _{CC} - 10 | | mV |
| | | Low level | | 60 | 180 | |
| I _{CC} | Supply current | LMV321 | | 80 | 170 | μA |
| | | LMV358 (both amplifiers) | | 140 | 340 | |
| | | LMV324 (all four amplifiers) | | 260 | 680 | |
| B ₁ | Unity-gain bandwidth | C _L = 200 pF | | 1 | | MHz |
| φ _m | Phase margin | | | 60 | | deg |
| G _m | Gain margin | | | 10 | | dB |
| V _n | Equivalent input noise voltage | f = 1 kHz | | 46 | | nV/√Hz |
| I _n | Equivalent input noise current | f = 1 kHz | | 0.17 | | pA/√Hz |

LMV321-Q1 SINGLE, LMV358-Q1 DUAL, LMV324-Q1 QUAD LOW-VOLTAGE RAIL-TO-RAIL OUTPUT OPERATIONAL AMPLIFIERS

SLOS415D – JUNE 2003 – REVISED OCTOBER 2004

electrical characteristics at specified free-air temperature range, $V_{CC+} = 5\text{ V}$ (unless otherwise noted)

| PARAMETER | | TEST CONDITIONS | T_A^\dagger | MIN | TYP | MAX | UNIT |
|-------------------|---|--|---------------|----------------|----------------|------|------------------------------|
| V_{IO} | Input offset voltage | | 25°C | | 1.7 | 7 | mV |
| | | | Full range | | | 9 | |
| $\alpha_{V_{IO}}$ | Average temperature coefficient of input offset voltage | | 25°C | | 5 | | $\mu\text{V}/^\circ\text{C}$ |
| I_{IB} | Input bias current | | 25°C | | 15 | 250 | nA |
| | | | Full range | | | 500 | |
| I_{IO} | Input offset current | | 25°C | | 5 | 50 | nA |
| | | | Full range | | | 150 | |
| CMRR | Common-mode rejection ratio | $V_{CM} = 0\text{ to }4\text{ V}$ | 25°C | 50 | 65 | | dB |
| k_{SVR} | Supply-voltage rejection ratio | $V_{CC} = 2.7\text{ V to }5\text{ V}$, $V_O = 1\text{ V}$, $V_{CM} = 1\text{ V}$ | 25°C | 50 | 60 | | dB |
| V_{ICR} | Common-mode input voltage range | $CMMR \geq 50\text{ dB}$ | 25°C | 0 to 4 | -0.2 to 4.2 | | V |
| Output swing | $R_L = 2\text{ k}\Omega\text{ to }2.5\text{ V}$ | High level | 25°C | $V_{CC} - 300$ | $V_{CC} - 40$ | | mV |
| | | | Full range | | $V_{CC} - 400$ | | |
| | | Low level | 25°C | | 120 | 300 | |
| | | | Full range | | | 400 | |
| | $R_L = 10\text{ k}\Omega\text{ to }2.5\text{ V}$ | High level | 25°C | $V_{CC} - 100$ | $V_{CC} - 10$ | | |
| | | | Full range | | $V_{CC} - 200$ | | |
| | | Low level | 25°C | | 65 | 180 | |
| | | | Full range | | | 280 | |
| A_{VD} | Large-signal differential voltage gain | $R_L = 2\text{ k}\Omega$ | 25°C | 15 | 100 | | V/mV |
| | | | Full range | | 10 | | |
| I_{OS} | Output short-circuit current | Sourcing, $V_O = 0\text{ V}$ | 25°C | 5 | 60 | | mA |
| | | Sinking, $V_O = 5\text{ V}$ | | 10 | 160 | | |
| I_{CC} | Supply current | LMV321 | 25°C | | 130 | 250 | μA |
| | | | Full range | | | 350 | |
| | | LMV358 (both amplifiers) | 25°C | | 210 | 440 | |
| | | | Full range | | | 615 | |
| | | LMV324 (all four amplifiers) | 25°C | | 410 | 830 | |
| | | | Full range | | | 1160 | |
| B_1 | Unity-gain bandwidth | $C_L = 200\text{ pF}$ | 25°C | | 1 | | MHz |
| ϕ_m | Phase margin | | 25°C | | 60 | | deg |
| G_m | Gain margin | | 25°C | | 10 | | dB |
| V_n | Equivalent input noise voltage | $f = 1\text{ kHz}$ | 25°C | | 39 | | $\text{nV}/\sqrt{\text{Hz}}$ |
| I_n | Equivalent input noise current | $f = 1\text{ kHz}$ | 25°C | | 0.21 | | $\text{pA}/\sqrt{\text{Hz}}$ |
| SR | Slew rate | | 25°C | | 1 | | $\text{V}/\mu\text{s}$ |

† Full range is -40°C to 85°C for I-level part, -40°C to 125°C for Q-level part.



**LMV321-Q1 SINGLE, LMV358-Q1 DUAL, LMV324-Q1 QUAD
LOW-VOLTAGE RAIL-TO-RAIL OUTPUT
OPERATIONAL AMPLIFIERS**

SLOS415D – JUNE 2003 – REVISED OCTOBER 2004

TYPICAL CHARACTERISTICS

**GAIN AND PHASE MARGIN
VS
FREQUENCY**

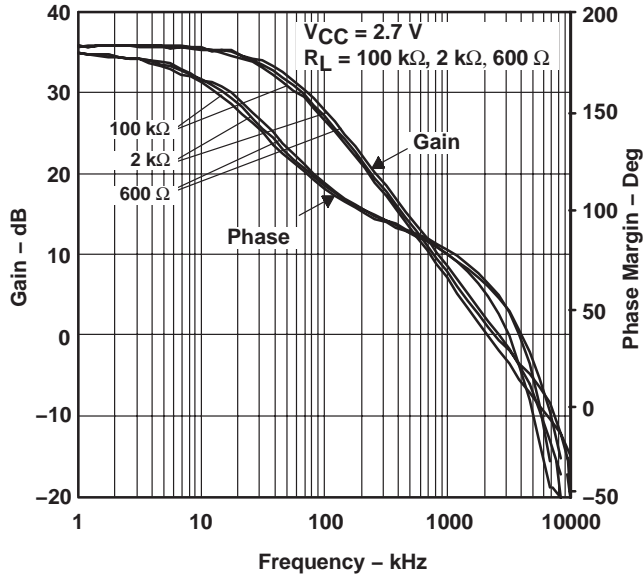

Figure 1

**GAIN AND PHASE MARGIN
VS
FREQUENCY**

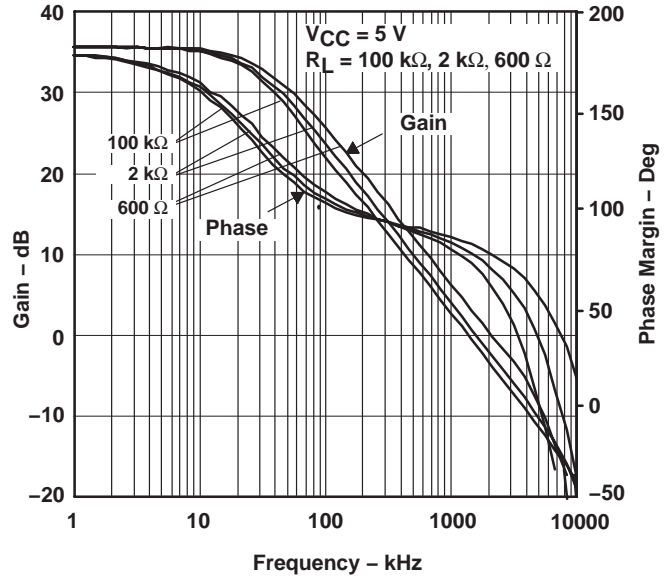

Figure 2

**GAIN AND PHASE MARGIN
VS
FREQUENCY**

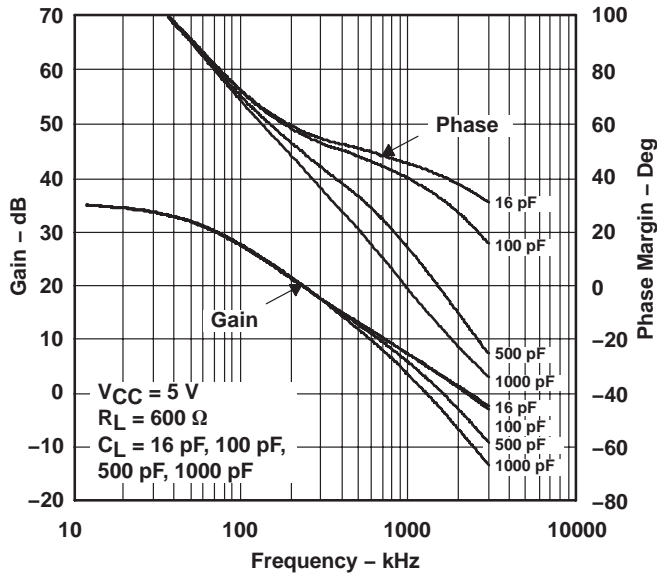

Figure 3

**GAIN AND PHASE MARGIN
VS
FREQUENCY**

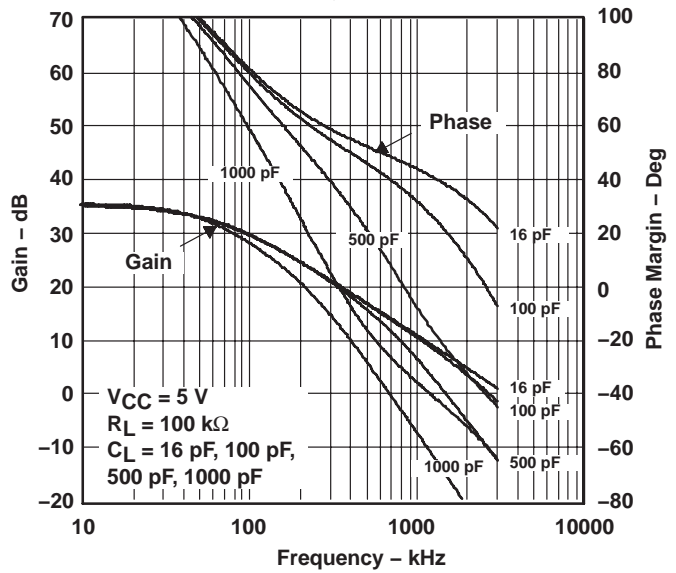

Figure 4



LMV321-Q1 SINGLE, LMV358-Q1 DUAL, LMV324-Q1 QUAD LOW-VOLTAGE RAIL-TO-RAIL OUTPUT OPERATIONAL AMPLIFIERS

SLOS415D – JUNE 2003 – REVISED OCTOBER 2004

TYPICAL CHARACTERISTICS

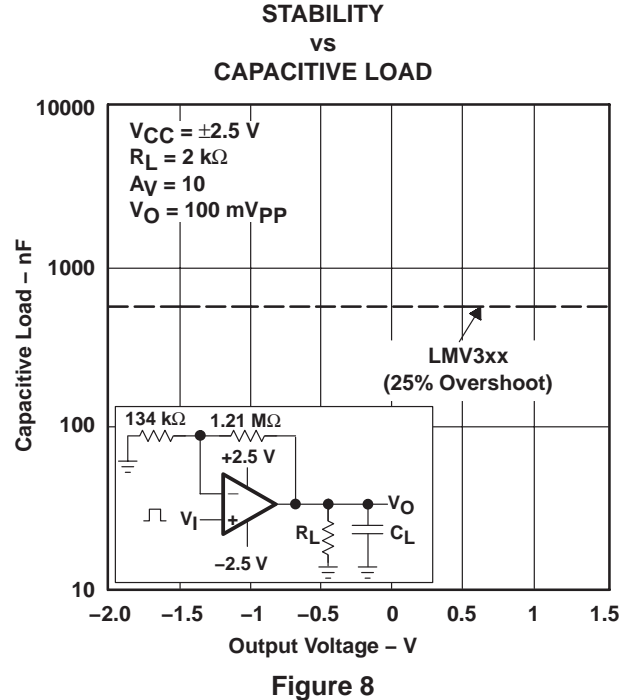
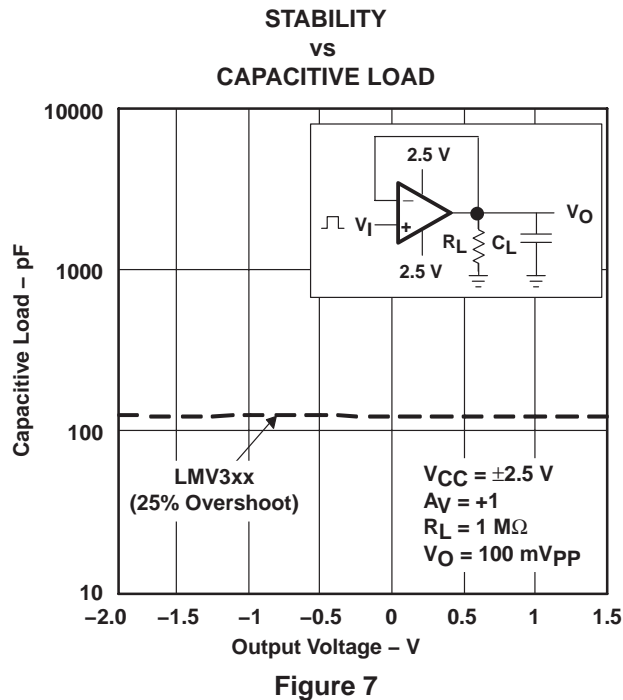
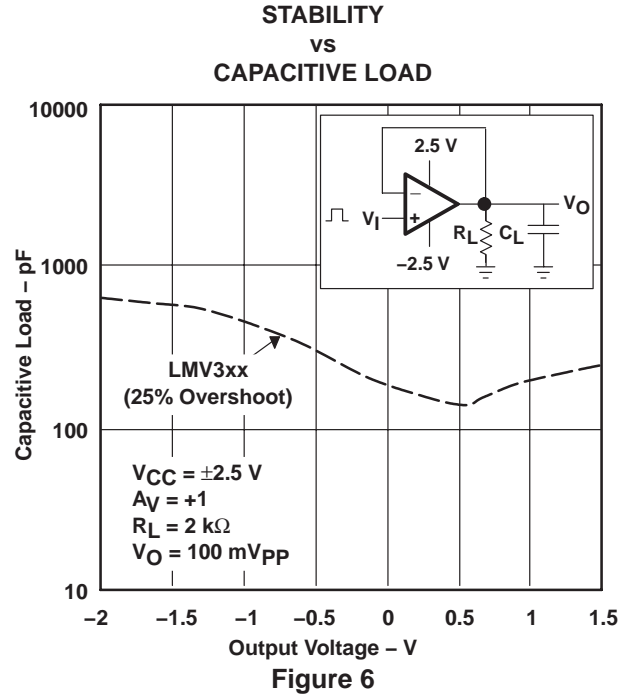
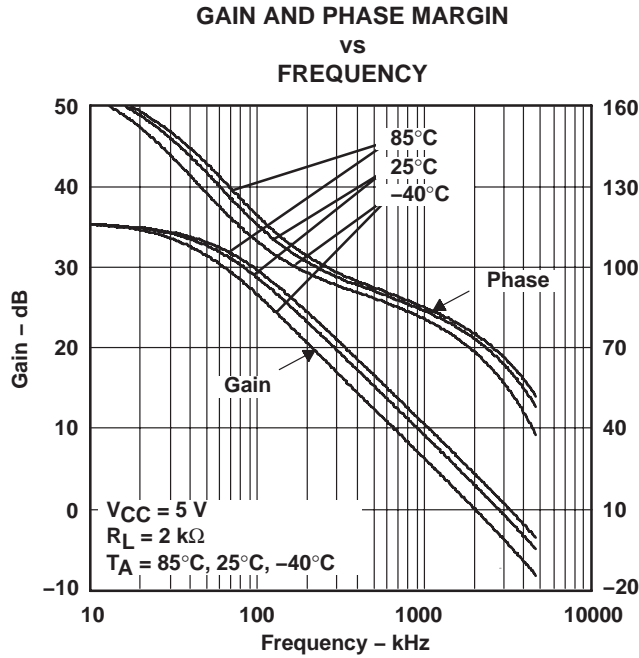

**LMV321-Q1 SINGLE, LMV358-Q1 DUAL, LMV324-Q1 QUAD
LOW-VOLTAGE RAIL-TO-RAIL OUTPUT
OPERATIONAL AMPLIFIERS**

SLOS415D – JUNE 2003 – REVISED OCTOBER 2004

TYPICAL CHARACTERISTICS

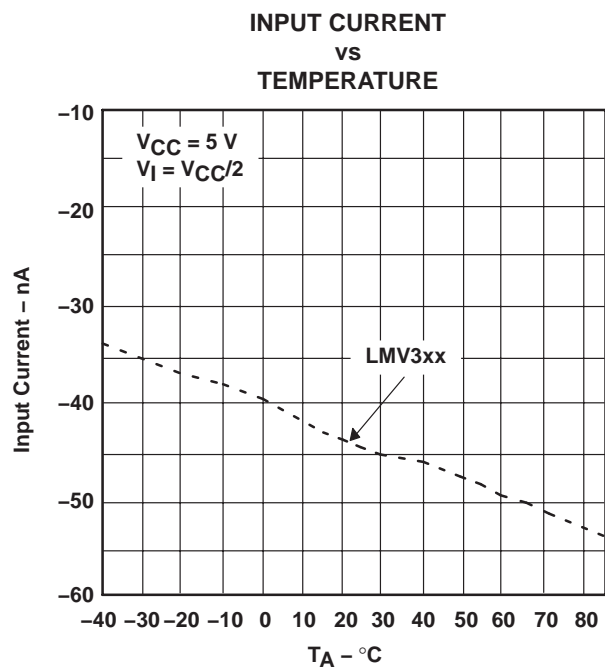
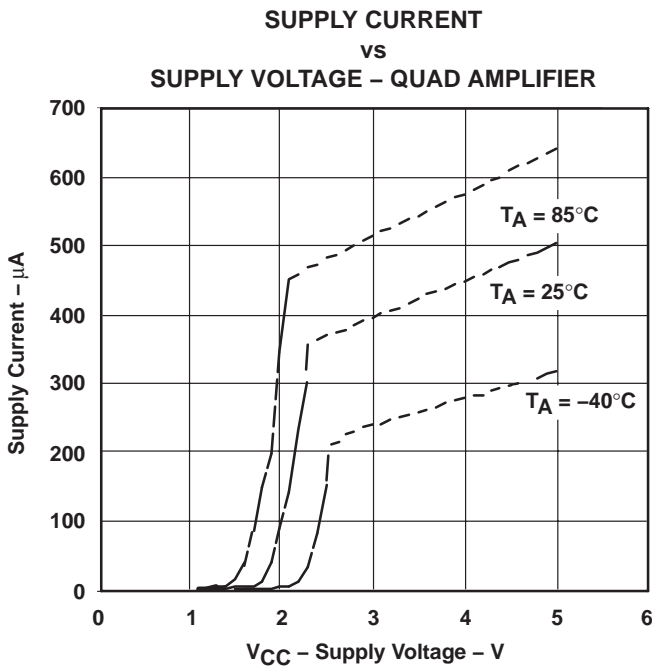
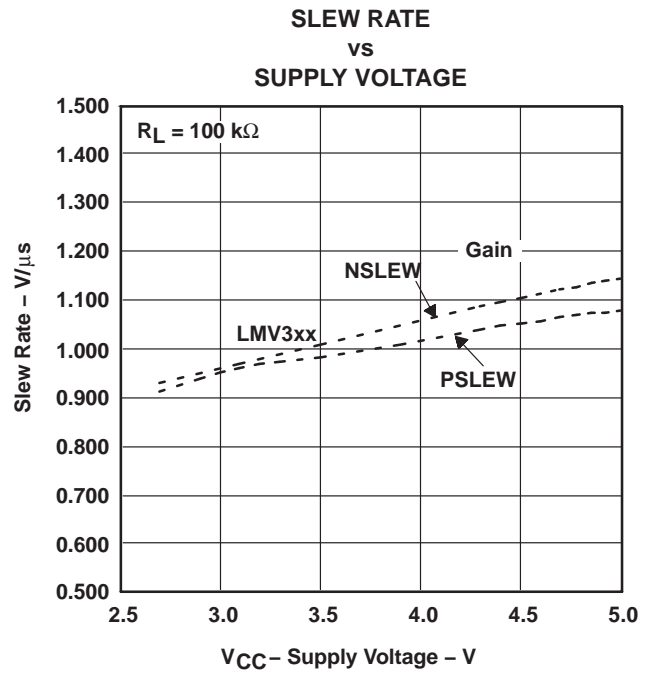
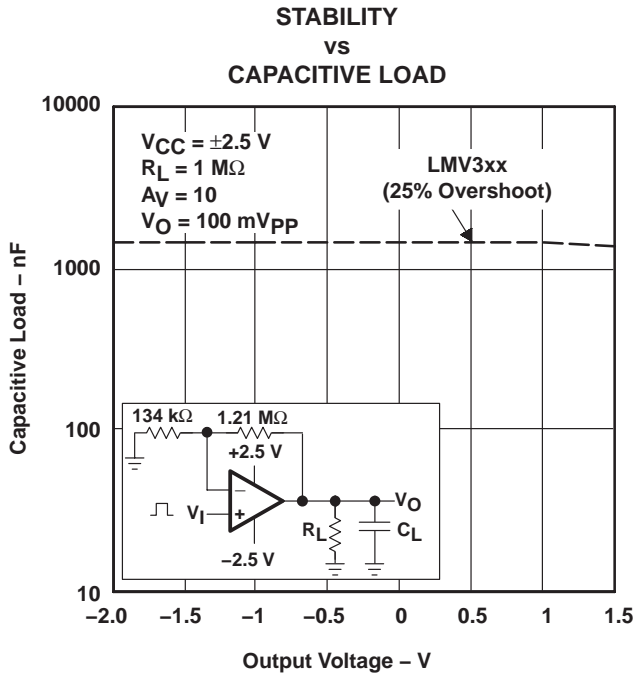

LMV321-Q1 SINGLE, LMV358-Q1 DUAL, LMV324-Q1 QUAD LOW-VOLTAGE RAIL-TO-RAIL OUTPUT OPERATIONAL AMPLIFIERS

SLOS415D – JUNE 2003 – REVISED OCTOBER 2004

TYPICAL CHARACTERISTICS

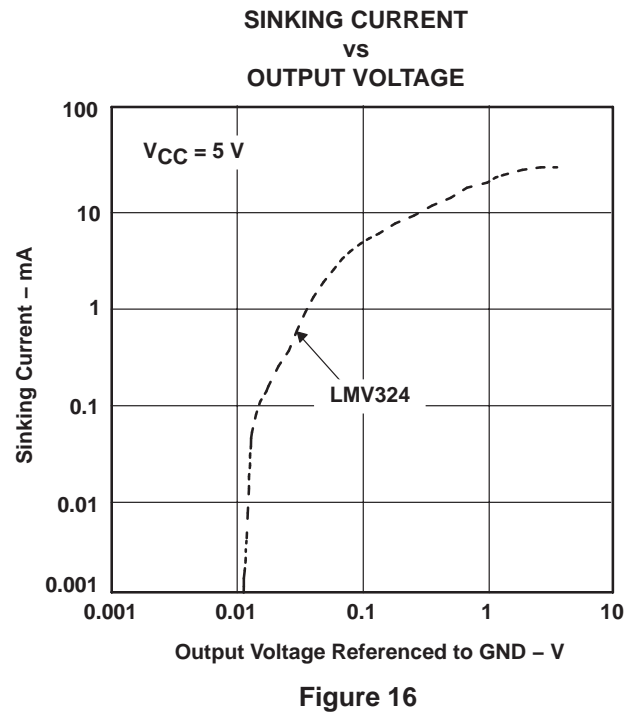
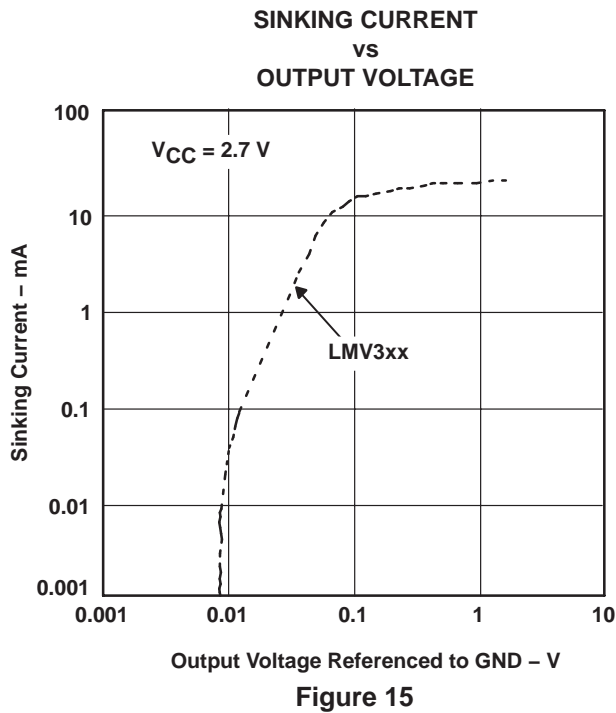
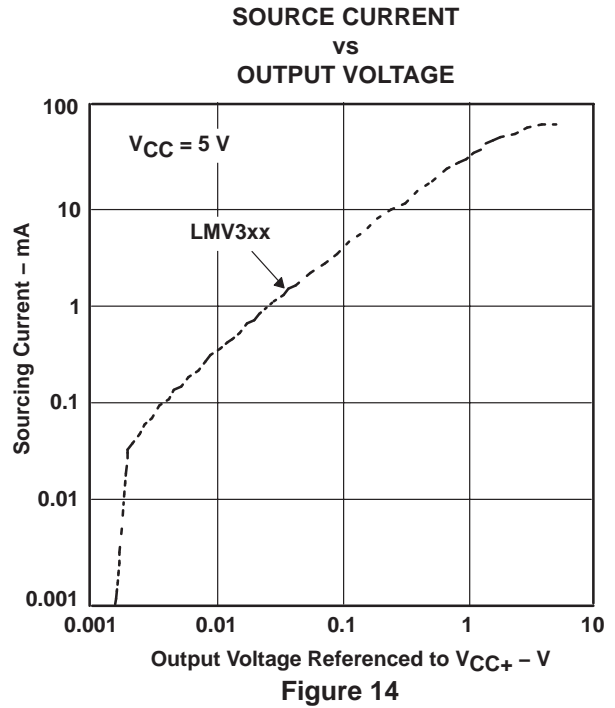
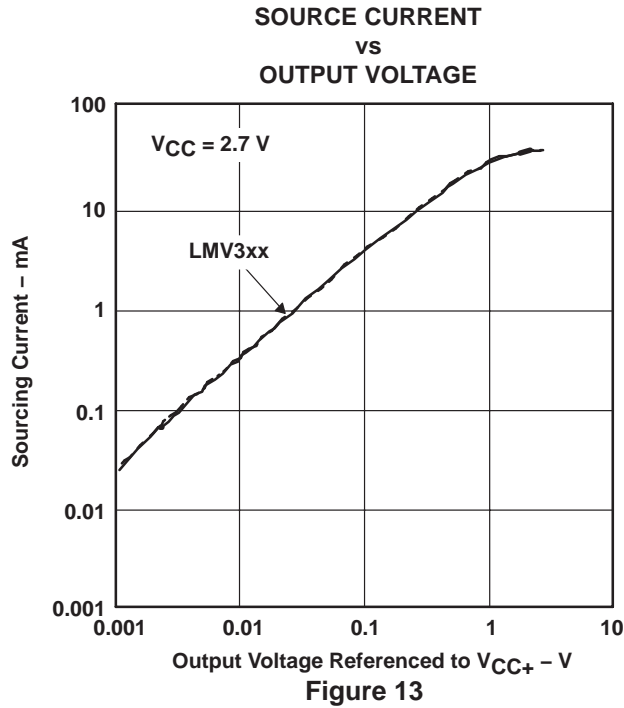

**LMV321-Q1 SINGLE, LMV358-Q1 DUAL, LMV324-Q1 QUAD
LOW-VOLTAGE RAIL-TO-RAIL OUTPUT
OPERATIONAL AMPLIFIERS**

SLOS415D – JUNE 2003 – REVISED OCTOBER 2004

TYPICAL CHARACTERISTICS

**SHORT-CIRCUIT CURRENT
vs
TEMPERATURE**

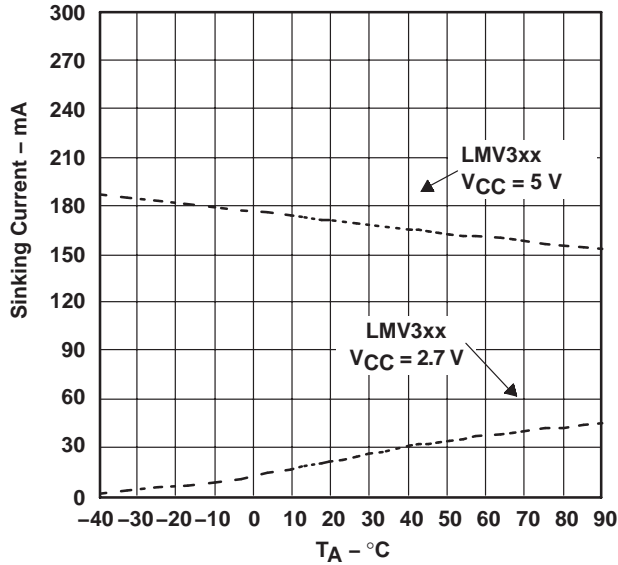

Figure 17

**SHORT-CIRCUIT CURRENT
vs
TEMPERATURE**

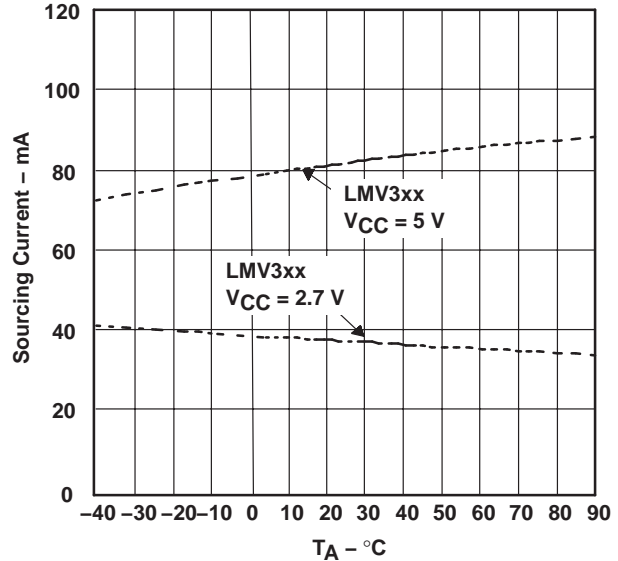

Figure 18

**-k_{SVR}
vs
FREQUENCY**

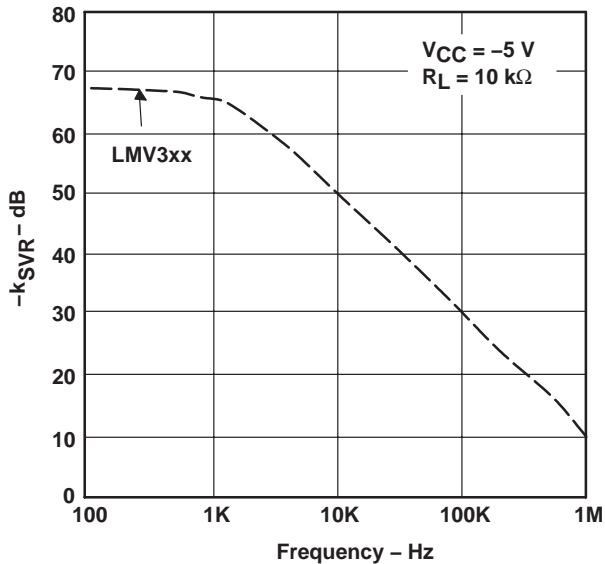

Figure 19

**+k_{SVR}
vs
FREQUENCY**

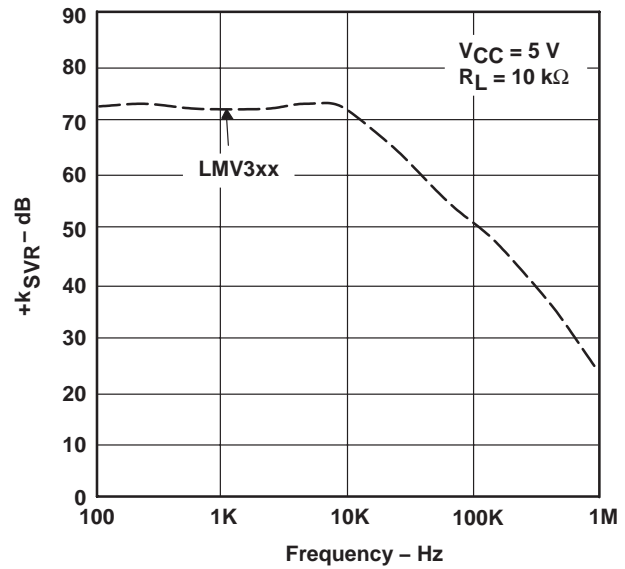
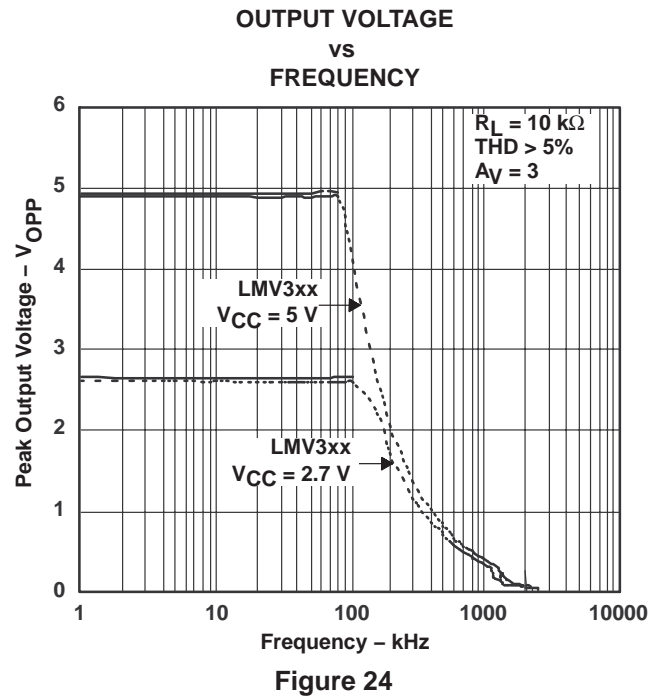
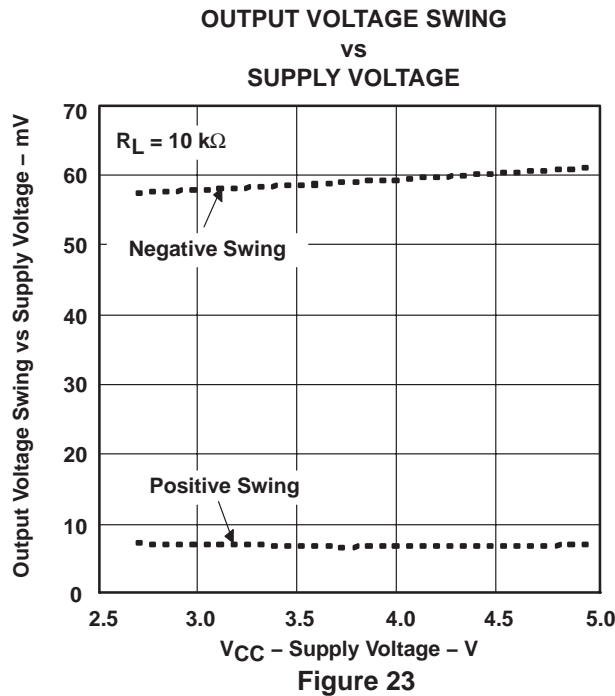
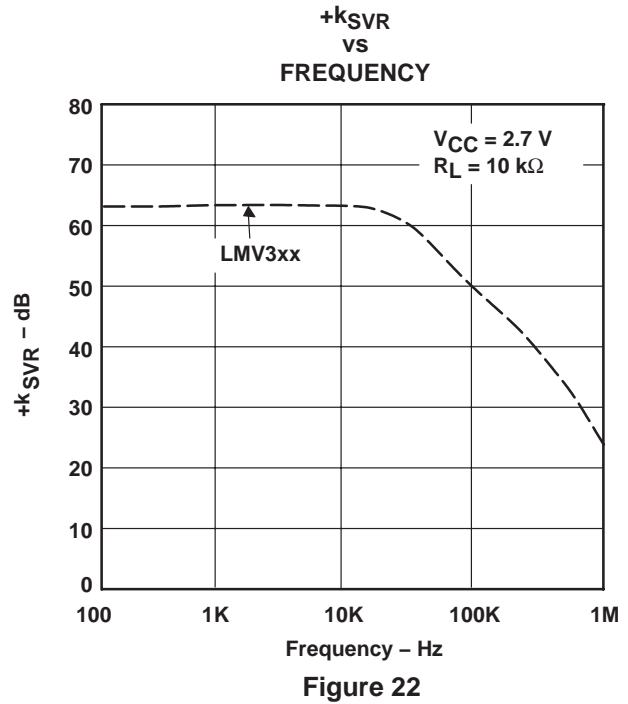
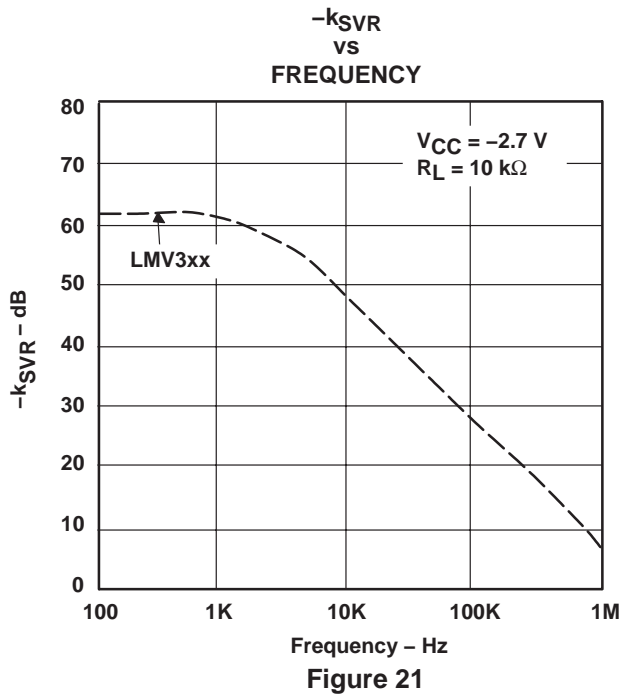

Figure 20

LMV321-Q1 SINGLE, LMV358-Q1 DUAL, LMV324-Q1 QUAD LOW-VOLTAGE RAIL-TO-RAIL OUTPUT OPERATIONAL AMPLIFIERS

SLOS415D – JUNE 2003 – REVISED OCTOBER 2004

TYPICAL CHARACTERISTICS



**LMV321-Q1 SINGLE, LMV358-Q1 DUAL, LMV324-Q1 QUAD
LOW-VOLTAGE RAIL-TO-RAIL OUTPUT
OPERATIONAL AMPLIFIERS**

SLOS415D – JUNE 2003 – REVISED OCTOBER 2004

TYPICAL CHARACTERISTICS

**OPEN-LOOP OUTPUT IMPEDANCE
VS
FREQUENCY**

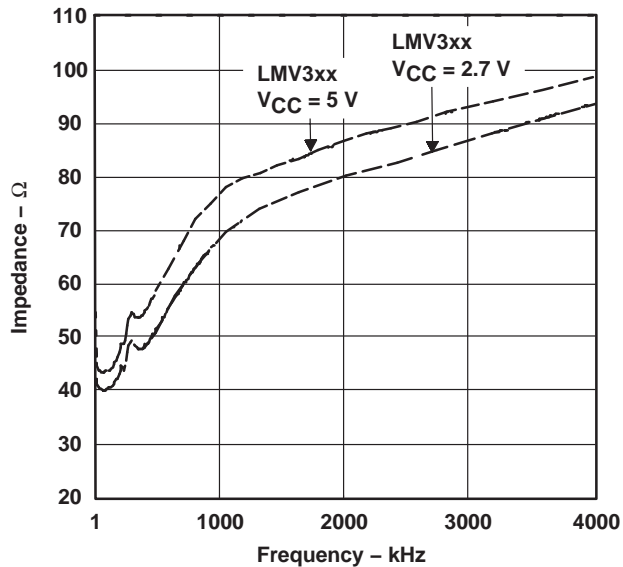

Figure 25

**CROSSTALK REJECTION
VS
FREQUENCY**

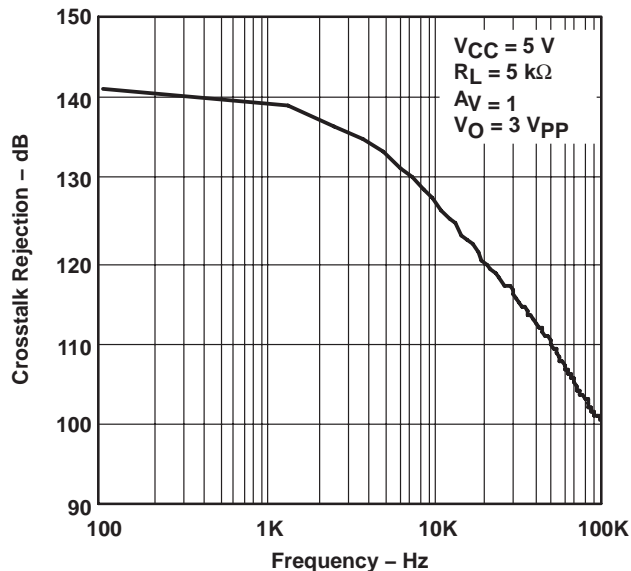
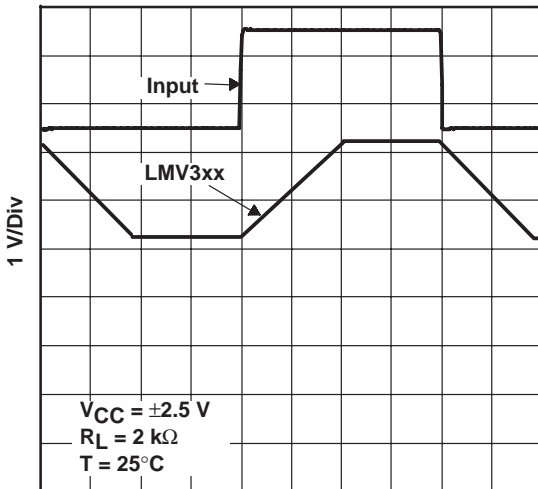

Figure 26

TYPICAL CHARACTERISTICS

NONINVERTING LARGE-SIGNAL
PULSE RESPONSE



1 $\mu\text{s}/\text{Div}$
Figure 27

NONINVERTING LARGE-SIGNAL
PULSE RESPONSE

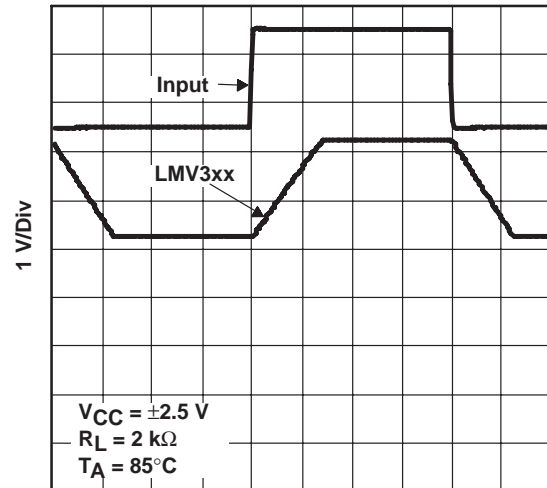

1 $\mu\text{s}/\text{Div}$
Figure 28

NONINVERTING LARGE-SIGNAL
PULSE RESPONSE

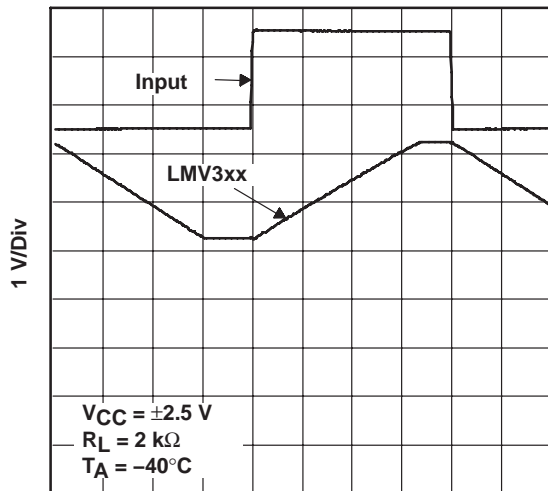

1 $\mu\text{s}/\text{Div}$
Figure 29

LMV321-Q1 SINGLE, LMV358-Q1 DUAL, LMV324-Q1 QUAD LOW-VOLTAGE RAIL-TO-RAIL OUTPUT OPERATIONAL AMPLIFIERS

SLOS415D – JUNE 2003 – REVISED OCTOBER 2004

TYPICAL CHARACTERISTICS

NONINVERTING SMALL-SIGNAL PULSE RESPONSE

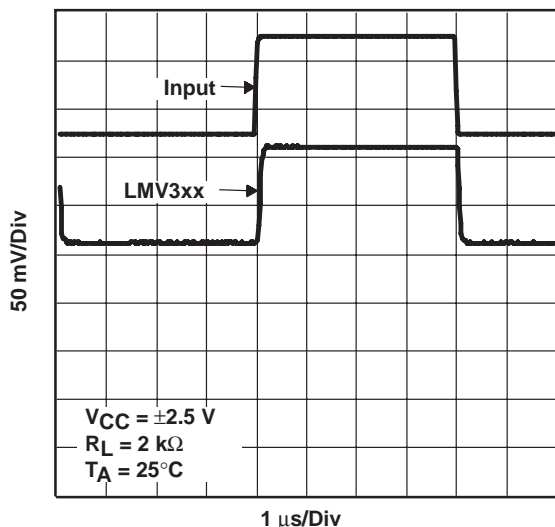

Figure 30

NONINVERTING SMALL-SIGNAL PULSE RESPONSE

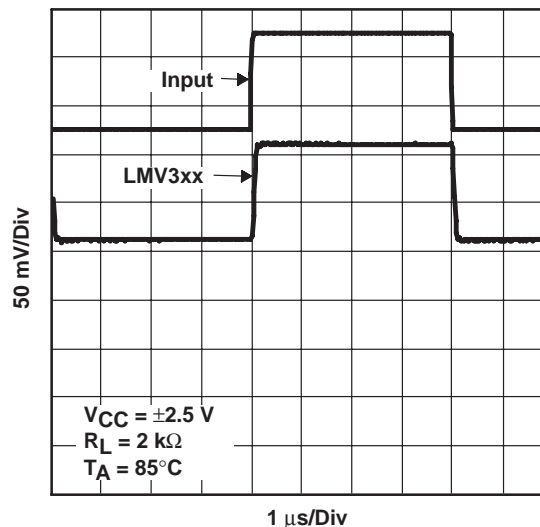

Figure 31

NONINVERTING SMALL-SIGNAL PULSE RESPONSE

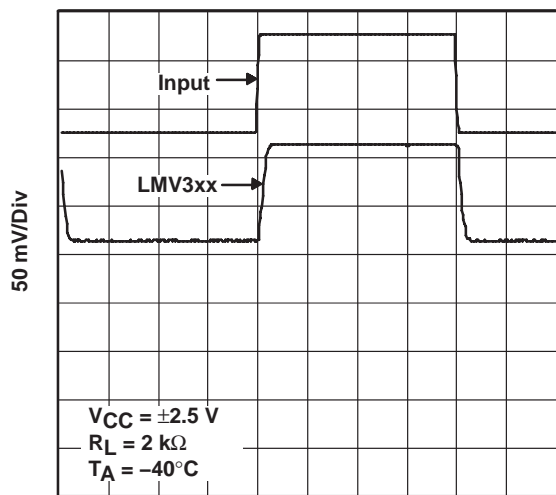

Figure 32

LMV321-Q1 SINGLE, LMV358-Q1 DUAL, LMV324-Q1 QUAD LOW-VOLTAGE RAIL-TO-RAIL OUTPUT OPERATIONAL AMPLIFIERS

SLOS415D – JUNE 2003 – REVISED OCTOBER 2004

TYPICAL CHARACTERISTICS

INVERTING LARGE-SIGNAL PULSE RESPONSE

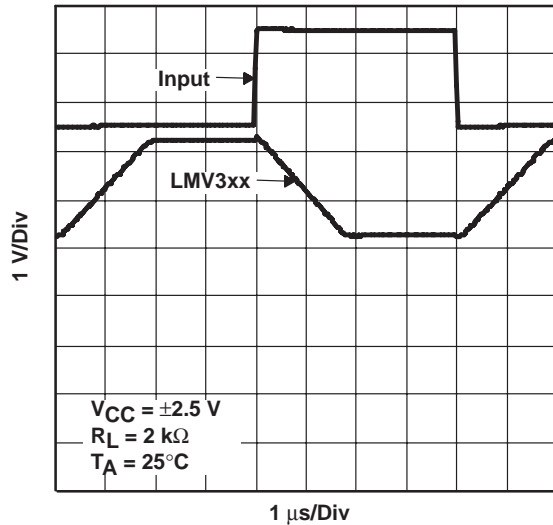

Figure 33

INVERTING LARGE-SIGNAL PULSE RESPONSE

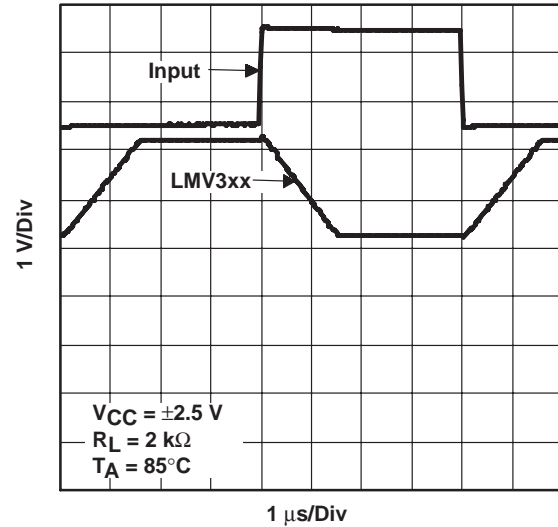

Figure 34

INVERTING LARGE-SIGNAL PULSE RESPONSE

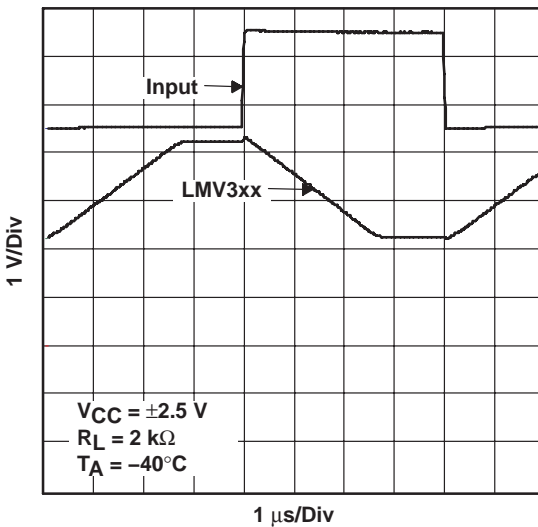

Figure 35

LMV321-Q1 SINGLE, LMV358-Q1 DUAL, LMV324-Q1 QUAD LOW-VOLTAGE RAIL-TO-RAIL OUTPUT OPERATIONAL AMPLIFIERS

SLOS415D – JUNE 2003 – REVISED OCTOBER 2004

TYPICAL CHARACTERISTICS

INVERTING SMALL-SIGNAL PULSE RESPONSE

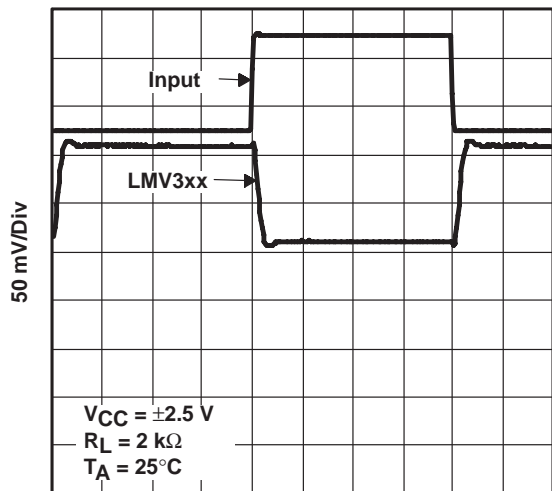

1 $\mu\text{s}/\text{Div}$
Figure 36

INVERTING SMALL-SIGNAL PULSE RESPONSE

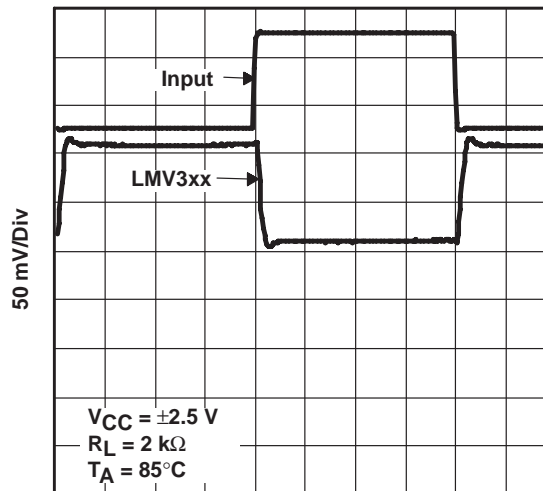

1 $\mu\text{s}/\text{Div}$
Figure 37

INVERTING SMALL-SIGNAL PULSE RESPONSE

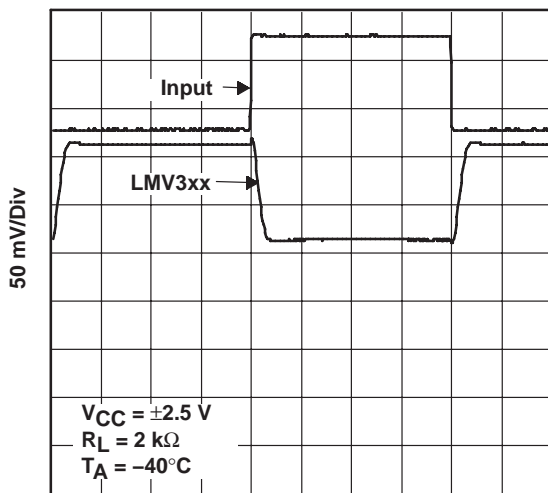

1 $\mu\text{s}/\text{Div}$
Figure 38

LMV321-Q1 SINGLE, LMV358-Q1 DUAL, LMV324-Q1 QUAD
 LOW-VOLTAGE RAIL-TO-RAIL OUTPUT
 OPERATIONAL AMPLIFIERS

SLOS415D – JUNE 2003 – REVISED OCTOBER 2004

TYPICAL CHARACTERISTICS

INPUT CURRENT NOISE
 vs
 FREQUENCY

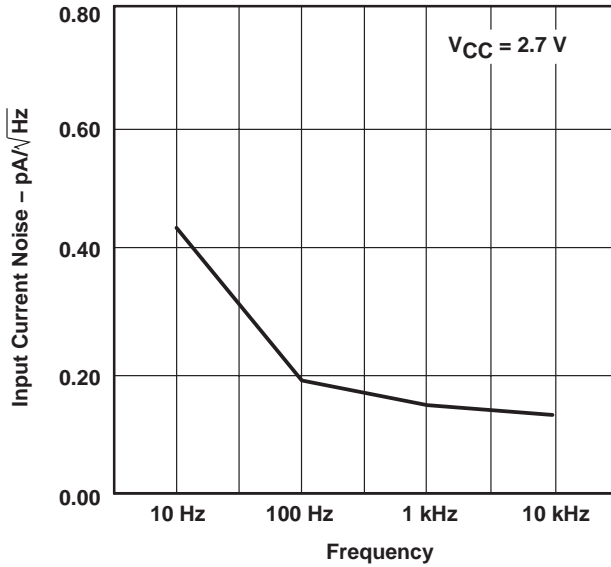

Figure 39

INPUT CURRENT NOISE
 vs
 FREQUENCY

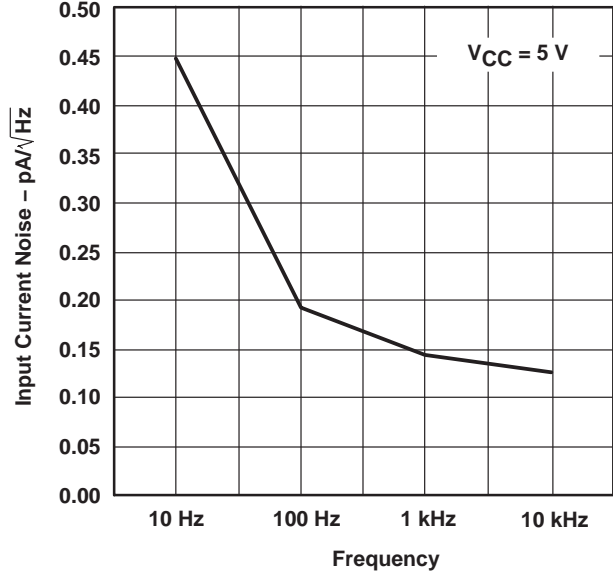

Figure 40

INPUT VOLTAGE NOISE
 vs
 FREQUENCY

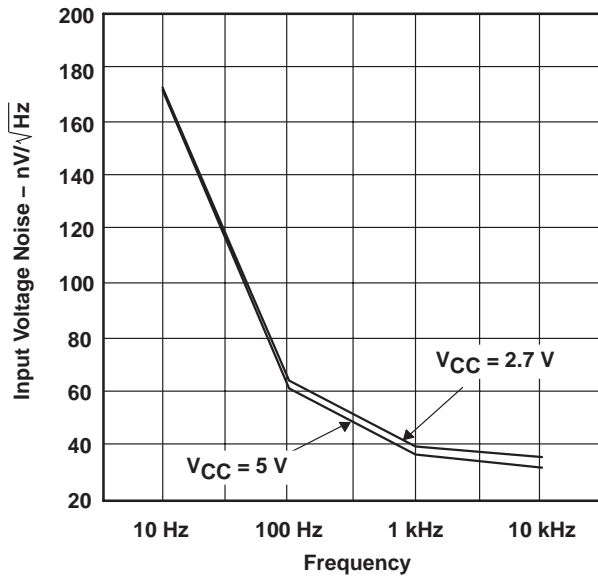
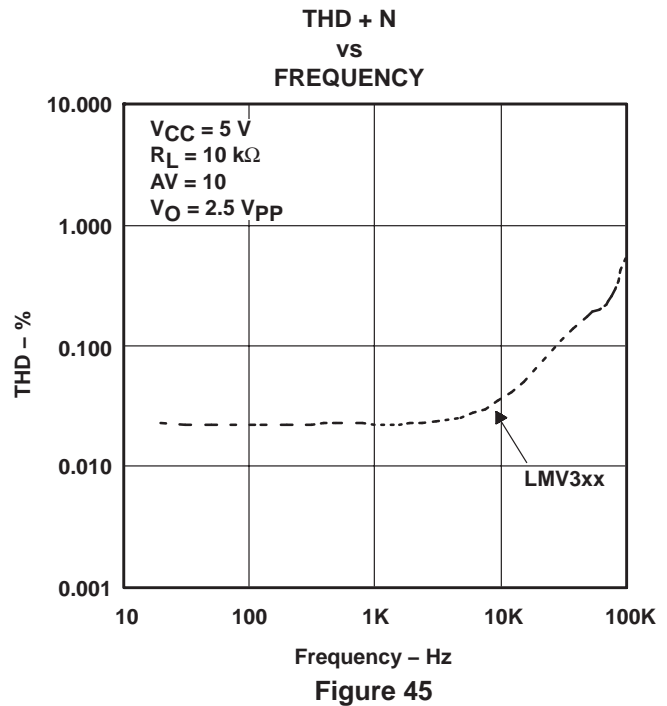
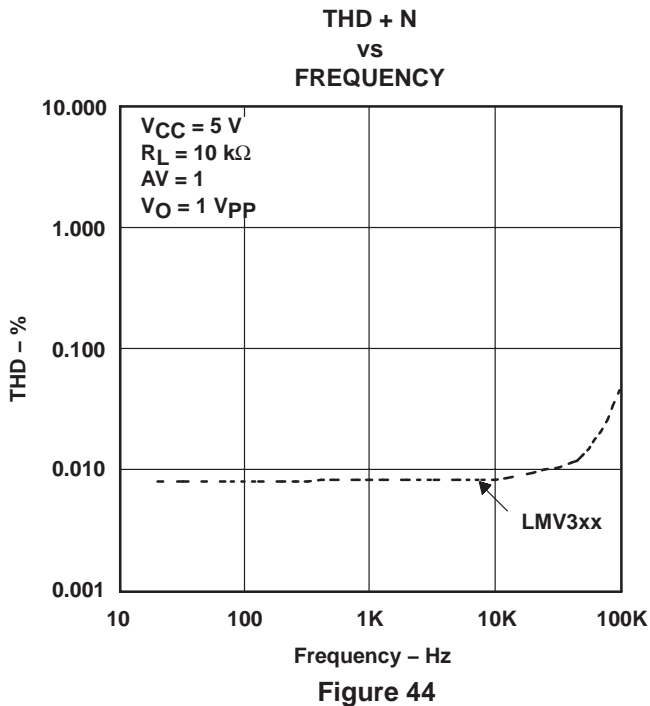
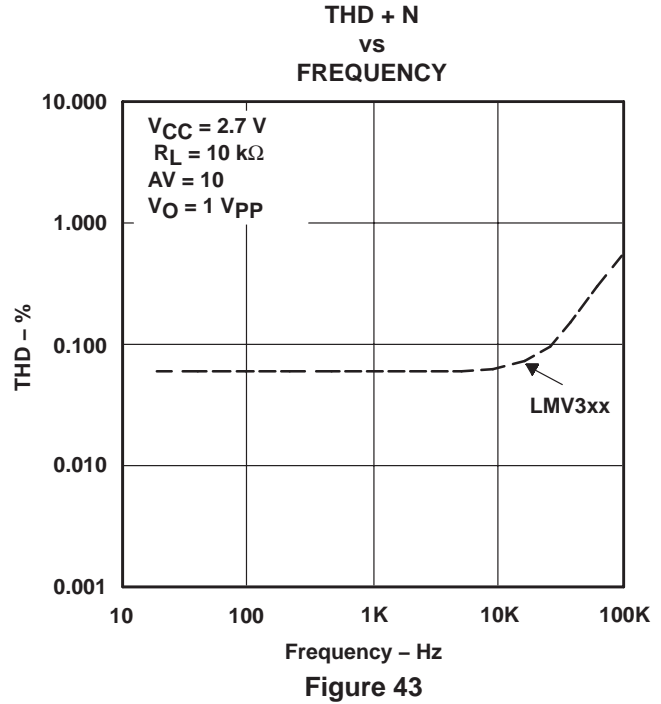
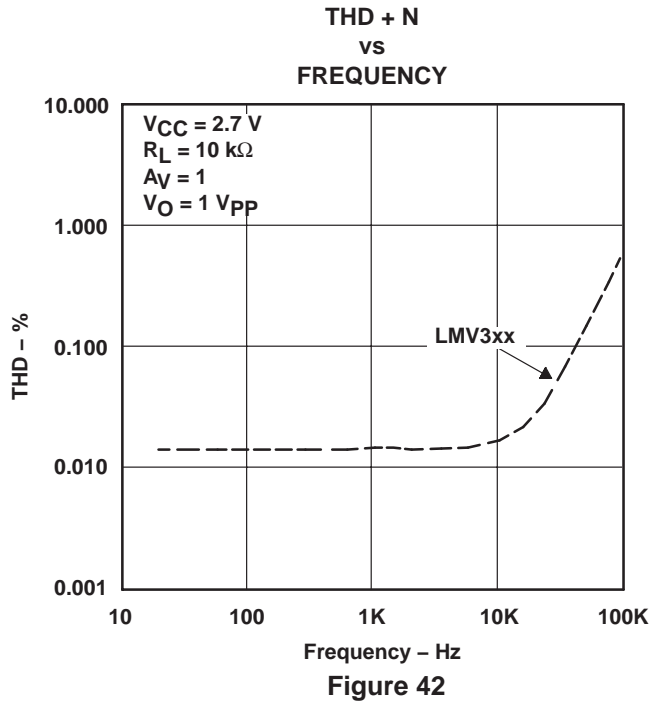

Figure 41

**LMV321-Q1 SINGLE, LMV358-Q1 DUAL, LMV324-Q1 QUAD
LOW-VOLTAGE RAIL-TO-RAIL OUTPUT
OPERATIONAL AMPLIFIERS**

SLOS415D – JUNE 2003 – REVISED OCTOBER 2004

TYPICAL CHARACTERISTICS



PACKAGING INFORMATION

| Orderable Device | Status ⁽¹⁾ | Package Type | Package Drawing | Pins | Package Qty | Eco Plan ⁽²⁾ | Lead/Ball Finish | MSL Peak Temp ⁽³⁾ |
|------------------|-----------------------|--------------|-----------------|------|-------------|-------------------------|------------------|--|
| LMV321IDBVRQ1 | ACTIVE | SOT-23 | DBV | 5 | 3000 | Green (RoHS & no Sb/Br) | CU NIPDAU | Level-1-260C-UNLIM |
| LMV321QDBVRQ1 | ACTIVE | SOT-23 | DBV | 5 | 3000 | Green (RoHS & no Sb/Br) | CU NIPDAU | Level-1-260C-UNLIM |
| LMV324IDRQ1 | ACTIVE | SOIC | D | 14 | 2500 | Pb-Free (RoHS) | CU NIPDAU | Level-2-250C-1 YEAR/ Level-1-235C-UNLIM |
| LMV324IPWRQ1 | ACTIVE | TSSOP | PW | 14 | 2000 | TBD | CU NIPDAU | Level-1-250C-UNLIM |
| LMV324QDQ1 | OBSOLETE | SOIC | D | 14 | | TBD | Call TI | Call TI |
| LMV324QDRG4Q1 | ACTIVE | SOIC | D | 14 | 2500 | Green (RoHS & no Sb/Br) | CU NIPDAU | Level-1-260C-UNLIM |
| LMV324QDRQ1 | ACTIVE | SOIC | D | 14 | 2500 | Pb-Free (RoHS) | CU NIPDAU | Level-2-250C-1 YEAR/ Level-1-235C-UNLIM |
| LMV324QPWRQ1 | ACTIVE | TSSOP | PW | 14 | 2000 | TBD | CU NIPDAU | Level-1-250C-UNLIM |
| LMV358IDRQ1 | ACTIVE | SOIC | D | 8 | 2500 | Pb-Free (RoHS) | CU NIPDAU | Level-2-250C-1 YEAR/ Level-1-235C-UNLIM |
| LMV358IPWRQ1 | ACTIVE | TSSOP | PW | 8 | 2000 | TBD | CU NIPDAU | Level-1-250C-UNLIM |
| LMV358QDQ1 | OBSOLETE | SOIC | D | 8 | | TBD | Call TI | Call TI |
| LMV358QDRQ1 | ACTIVE | SOIC | D | 8 | 2500 | Pb-Free (RoHS) | CU NIPDAU | Level-2-250C-1 YEAR/ Level-1-235C-UNLIM |
| LMV358QPWQ1 | OBSOLETE | TSSOP | PW | 8 | | TBD | Call TI | Call TI |
| LMV358QPWRQ1 | ACTIVE | TSSOP | PW | 8 | 2000 | TBD | CU NIPDAU | Level-1-250C-UNLIM |

⁽¹⁾ The marketing status values are defined as follows:

ACTIVE: Product device recommended for new designs.

LIFEBUY: TI has announced that the device will be discontinued, and a lifetime-buy period is in effect.

NRND: Not recommended for new designs. Device is in production to support existing customers, but TI does not recommend using this part in a new design.

PREVIEW: Device has been announced but is not in production. Samples may or may not be available.

OBSOLETE: TI has discontinued the production of the device.

⁽²⁾ Eco Plan - The planned eco-friendly classification: Pb-Free (RoHS), Pb-Free (RoHS Exempt), or Green (RoHS & no Sb/Br) - please check <http://www.ti.com/productcontent> for the latest availability information and additional product content details.

TBD: The Pb-Free/Green conversion plan has not been defined.

Pb-Free (RoHS): TI's terms "Lead-Free" or "Pb-Free" mean semiconductor products that are compatible with the current RoHS requirements for all 6 substances, including the requirement that lead not exceed 0.1% by weight in homogeneous materials. Where designed to be soldered at high temperatures, TI Pb-Free products are suitable for use in specified lead-free processes.

Pb-Free (RoHS Exempt): This component has a RoHS exemption for either 1) lead-based flip-chip solder bumps used between the die and package, or 2) lead-based die adhesive used between the die and leadframe. The component is otherwise considered Pb-Free (RoHS compatible) as defined above.

Green (RoHS & no Sb/Br): TI defines "Green" to mean Pb-Free (RoHS compatible), and free of Bromine (Br) and Antimony (Sb) based flame retardants (Br or Sb do not exceed 0.1% by weight in homogeneous material)

⁽³⁾ MSL, Peak Temp. -- The Moisture Sensitivity Level rating according to the JEDEC industry standard classifications, and peak solder temperature.

Important Information and Disclaimer:The information provided on this page represents TI's knowledge and belief as of the date that it is provided. TI bases its knowledge and belief on information provided by third parties, and makes no representation or warranty as to the accuracy of such information. Efforts are underway to better integrate information from third parties. TI has taken and continues to take reasonable steps to provide representative and accurate information but may not have conducted destructive testing or chemical analysis on incoming materials and chemicals. TI and TI suppliers consider certain information to be proprietary, and thus CAS numbers and other limited information may not be available for release.

In no event shall TI's liability arising out of such information exceed the total purchase price of the TI part(s) at issue in this document sold by TI

to Customer on an annual basis.

D (R-PDSO-G14)

PLASTIC SMALL-OUTLINE PACKAGE

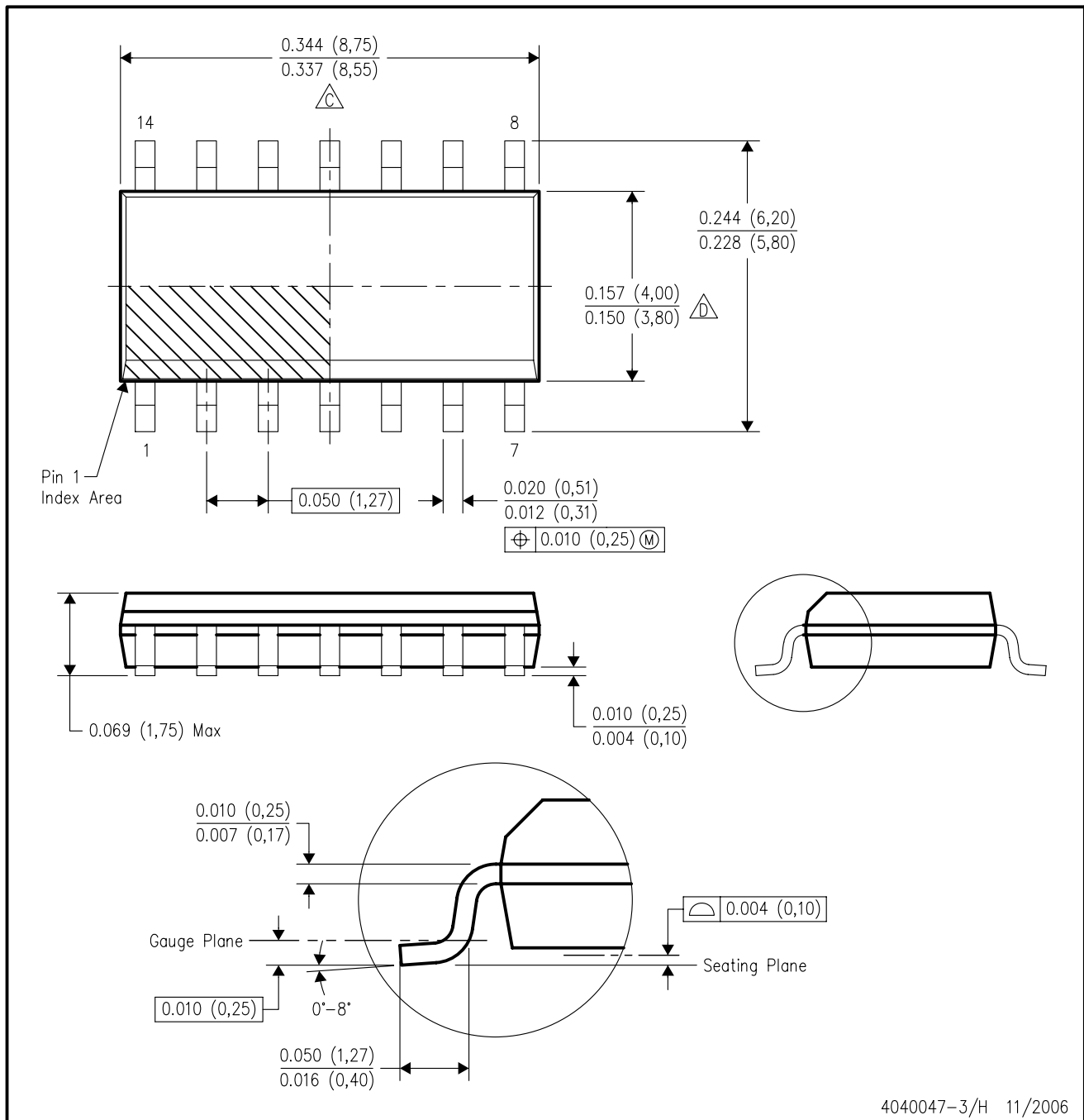

- NOTES:
- A. All linear dimensions are in inches (millimeters).
 - B. This drawing is subject to change without notice.
 - C. Body length does not include mold flash, protrusions, or gate burrs. Mold flash, protrusions, or gate burrs shall not exceed .006 (0,15) per end.
 - D. Body width does not include interlead flash. Interlead flash shall not exceed .017 (0,43) per side.
 - E. Reference JEDEC MS-012 variation AB.

D (R-PDSO-G8)

PLASTIC SMALL-OUTLINE PACKAGE

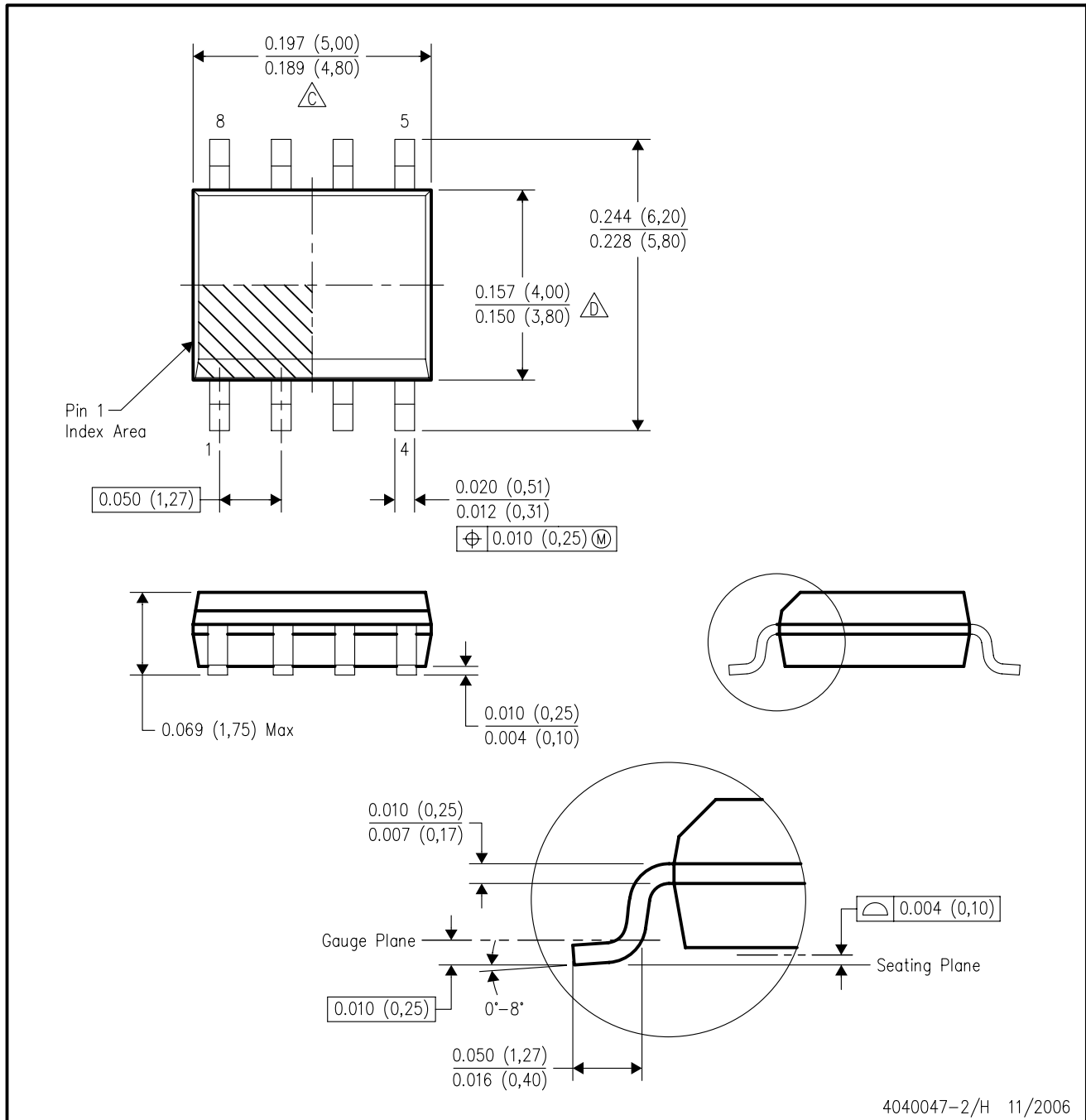

- NOTES:
- A. All linear dimensions are in inches (millimeters).
 - B. This drawing is subject to change without notice.
 - C. Body length does not include mold flash, protrusions, or gate burrs. Mold flash, protrusions, or gate burrs shall not exceed .006 (0,15) per end.
 - D. Body width does not include interlead flash. Interlead flash shall not exceed .017 (0,43) per side.
 - E. Reference JEDEC MS-012 variation AA.

PW (R-PDSO-G**)

PLASTIC SMALL-OUTLINE PACKAGE

14 PINS SHOWN



4040064/F 01/97

- NOTES: A. All linear dimensions are in millimeters.
 B. This drawing is subject to change without notice.
 C. Body dimensions do not include mold flash or protrusion not to exceed 0,15.
 D. Falls within JEDEC MO-153

IMPORTANT NOTICE

Texas Instruments Incorporated and its subsidiaries (TI) reserve the right to make corrections, modifications, enhancements, improvements, and other changes to its products and services at any time and to discontinue any product or service without notice. Customers should obtain the latest relevant information before placing orders and should verify that such information is current and complete. All products are sold subject to TI's terms and conditions of sale supplied at the time of order acknowledgment.

TI warrants performance of its hardware products to the specifications applicable at the time of sale in accordance with TI's standard warranty. Testing and other quality control techniques are used to the extent TI deems necessary to support this warranty. Except where mandated by government requirements, testing of all parameters of each product is not necessarily performed.

TI assumes no liability for applications assistance or customer product design. Customers are responsible for their products and applications using TI components. To minimize the risks associated with customer products and applications, customers should provide adequate design and operating safeguards.

TI does not warrant or represent that any license, either express or implied, is granted under any TI patent right, copyright, mask work right, or other TI intellectual property right relating to any combination, machine, or process in which TI products or services are used. Information published by TI regarding third-party products or services does not constitute a license from TI to use such products or services or a warranty or endorsement thereof. Use of such information may require a license from a third party under the patents or other intellectual property of the third party, or a license from TI under the patents or other intellectual property of TI.

Reproduction of TI information in TI data books or data sheets is permissible only if reproduction is without alteration and is accompanied by all associated warranties, conditions, limitations, and notices. Reproduction of this information with alteration is an unfair and deceptive business practice. TI is not responsible or liable for such altered documentation. Information of third parties may be subject to additional restrictions.

Resale of TI products or services with statements different from or beyond the parameters stated by TI for that product or service voids all express and any implied warranties for the associated TI product or service and is an unfair and deceptive business practice. TI is not responsible or liable for any such statements.

TI products are not authorized for use in safety-critical applications (such as life support) where a failure of the TI product would reasonably be expected to cause severe personal injury or death, unless officers of the parties have executed an agreement specifically governing such use. Buyers represent that they have all necessary expertise in the safety and regulatory ramifications of their applications, and acknowledge and agree that they are solely responsible for all legal, regulatory and safety-related requirements concerning their products and any use of TI products in such safety-critical applications, notwithstanding any applications-related information or support that may be provided by TI. Further, Buyers must fully indemnify TI and its representatives against any damages arising out of the use of TI products in such safety-critical applications.

TI products are neither designed nor intended for use in military/aerospace applications or environments unless the TI products are specifically designated by TI as military-grade or "enhanced plastic." Only products designated by TI as military-grade meet military specifications. Buyers acknowledge and agree that any such use of TI products which TI has not designated as military-grade is solely at the Buyer's risk, and that they are solely responsible for compliance with all legal and regulatory requirements in connection with such use.

TI products are neither designed nor intended for use in automotive applications or environments unless the specific TI products are designated by TI as compliant with ISO/TS 16949 requirements. Buyers acknowledge and agree that, if they use any non-designated products in automotive applications, TI will not be responsible for any failure to meet such requirements.

Following are URLs where you can obtain information on other Texas Instruments products and application solutions:

| Products | | Applications | |
|-----------------------|--|---------------------|--|
| Amplifiers | amplifier.ti.com | Audio | www.ti.com/audio |
| Data Converters | dataconverter.ti.com | Automotive | www.ti.com/automotive |
| DSP | dsp.ti.com | Broadband | www.ti.com/broadband |
| Interface | interface.ti.com | Digital Control | www.ti.com/digitalcontrol |
| Logic | logic.ti.com | Military | www.ti.com/military |
| Power Mgmt | power.ti.com | Optical Networking | www.ti.com/opticalnetwork |
| Microcontrollers | microcontroller.ti.com | Security | www.ti.com/security |
| RFID | www.ti-rfid.com | Telephony | www.ti.com/telephony |
| Low Power Wireless | www.ti.com/lpw | Video & Imaging | www.ti.com/video |
| | | Wireless | www.ti.com/wireless |

Mailing Address: Texas Instruments, Post Office Box 655303, Dallas, Texas 75265
Copyright © 2007, Texas Instruments Incorporated