

## LMK61E2 Ultra-Low Jitter Programmable Oscillator with Internal EEPROM

### 1 Features

- Ultra-low Noise, High Performance
  - Jitter: 90 fs RMS typical  $f_{OUT} > 100$  MHz
  - PSRR: -70 dBc, robust supply noise immunity
- Flexible Output Format; User Selectable
  - LVPECL up to 1 GHz
  - LVDS up to 900 MHz
  - HCSL up to 400 MHz
- Total frequency tolerance of  $\pm 50$  ppm
- System Level Features
  - Frequency margining: fine and coarse
  - Internal EEPROM: user configurable default settings
- Other Features
  - Device control: I<sup>2</sup>C
  - 3.3 V operating voltage
  - Industrial temperature range (-40°C to +85°C)
  - 7 mm x 5 mm 8-pin package

### 2 Applications

- High-performance replacement for crystal-, SAW-, or silicon-based Oscillators
- Switches, Routers, Network Line Cards, Base Band Units (BBU), Servers, Storage/SAN
- Test and Measurement
- Medical Imaging
- FPGA, Processor Attach

### 3 Description

The LMK61E2 is an ultra-low jitter PLLatinum™ programmable oscillator with a fractional-N frequency synthesizer with integrated VCO that generates commonly used reference clocks. The outputs can be configured as LVPECL or LVDS or HCSL.

The device features self startup from on-chip EEPROM that is factory programmed to generate 156.25 MHz LVPECL output. The device registers and EEPROM settings are fully programmable in-system via I<sup>2</sup>C serial interface. Internal power conditioning provide excellent power supply ripple rejection (PSRR), reducing the cost and complexity of the power delivery network. The device operates from a single 3.3 V  $\pm 5\%$  supply.

The device provides fine and coarse frequency margining options via I<sup>2</sup>C serial interface to support system design verification tests (DVT), such as standard compliance and system timing margin testing.

#### Device Information<sup>(1)</sup>

PART NUMBER	PACKAGE	BODY SIZE (NOM)
LMK61E2	8-pin QFM (SIA)	7.0 mm x 5.0 mm

(1) For all available packages, see the orderable addendum at the end of the data sheet.

#### Pinout and Simplified Block Diagram

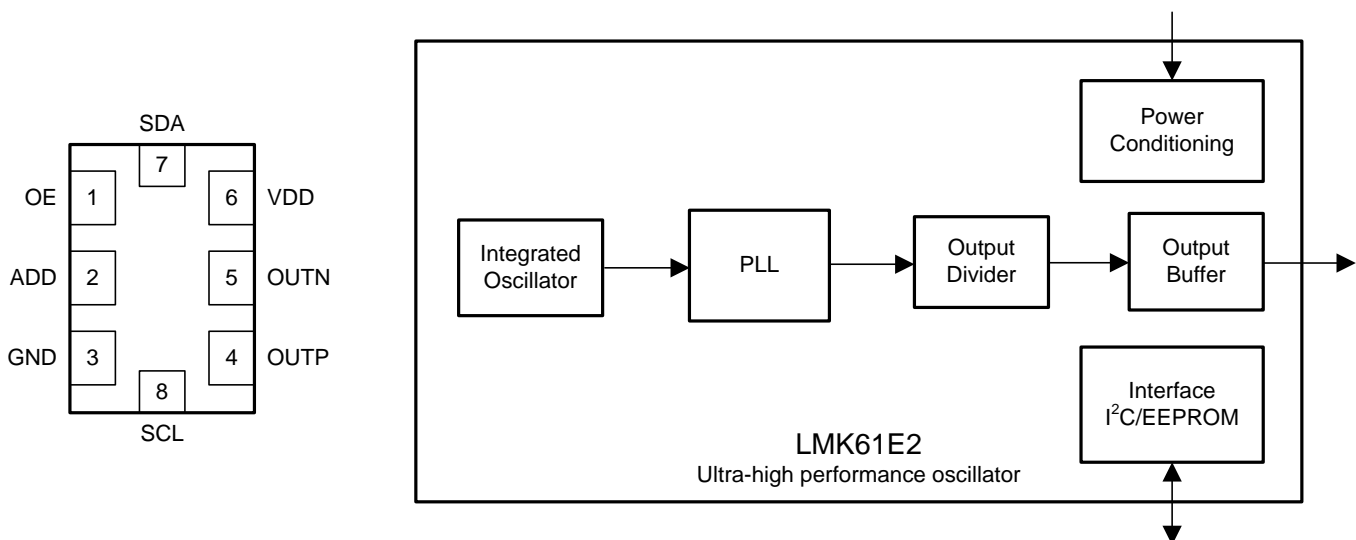

## Table of Contents

<b>1 Features</b> .....	<b>1</b>	Characteristics .....	<b>8</b>
<b>2 Applications</b> .....	<b>1</b>	6.19 Additional Reliability and Qualification .....	<b>8</b>
<b>3 Description</b> .....	<b>1</b>	6.20 Typical Performance Characteristics .....	<b>9</b>
<b>4 Revision History</b> .....	<b>2</b>	<b>7 Parameter Measurement Information</b> .....	<b>12</b>
<b>5 Pin Configuration and Functions</b> .....	<b>3</b>	7.1 Device Output Configurations .....	<b>12</b>
<b>6 Specifications</b> .....	<b>3</b>	<b>8 Detailed Description</b> .....	<b>14</b>
6.1 Absolute Maximum Ratings .....	<b>3</b>	8.1 Overview .....	<b>14</b>
6.2 ESD Ratings .....	<b>3</b>	8.2 Functional Block Diagram .....	<b>14</b>
6.3 Recommended Operating Conditions .....	<b>4</b>	8.3 Feature Description .....	<b>14</b>
6.4 Thermal Information .....	<b>4</b>	8.4 Device Functional Modes .....	<b>18</b>
6.5 Electrical Characteristics - Power Supply .....	<b>4</b>	8.5 Programming .....	<b>19</b>
6.6 LVPECL Output Characteristics .....	<b>4</b>	8.6 Register Map .....	<b>23</b>
6.7 LVDS Output Characteristics .....	<b>5</b>	8.7 EEPROM Map .....	<b>34</b>
6.8 HCSL Output Characteristics .....	<b>5</b>	<b>9 Application and Implementation</b> .....	<b>35</b>
6.9 OE Input Characteristics .....	<b>5</b>	9.1 Application Information .....	<b>35</b>
6.10 ADD Input Characteristics .....	<b>6</b>	9.2 Typical Applications .....	<b>35</b>
6.11 Frequency Tolerance Characteristics .....	<b>6</b>	<b>10 Power Supply Recommendations</b> .....	<b>41</b>
6.12 Power-On/Reset Characteristics (VDD) .....	<b>6</b>	<b>11 Layout</b> .....	<b>42</b>
6.13 I <sup>2</sup> C-Compatible Interface Characteristics (SDA, SCL) .....	<b>6</b>	11.1 Layout Guidelines .....	<b>42</b>
6.14 Spurious and PSRR Characteristics .....	<b>7</b>	<b>12 Device and Documentation Support</b> .....	<b>43</b>
6.15 Other Characteristics .....	<b>7</b>	12.1 Community Resources .....	<b>43</b>
6.16 PLL Clock Output Jitter Characteristics .....	<b>7</b>	12.2 Trademarks .....	<b>43</b>
6.17 Typical 156.25 MHz Output Phase Noise Characteristics .....	<b>7</b>	12.3 Electrostatic Discharge Caution .....	<b>43</b>
6.18 Typical 161.1328125 MHz Output Phase Noise Characteristics .....	<b>8</b>	12.4 Glossary .....	<b>43</b>
		<b>13 Mechanical, Packaging, and Orderable Information</b> .....	<b>43</b>

## 4 Revision History

DATE	REVISION	NOTES
September 2015	*	Initial Release

## 5 Pin Configuration and Functions

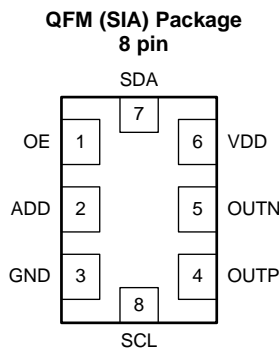

### Pin Functions

PIN		I/O	DESCRIPTION
NAME	NO.		
<b>POWER</b>			
GND	3	Ground	Device Ground.
VDD	6	Analog	3.3 V Power Supply.
<b>OUTPUT BLOCK</b>			
OUTP, OUTN	4, 5	Universal	Differential Output Pair (LVPECL, LVDS or HCSL).
<b>DIGITAL CONTROL / INTERFACES</b>			
ADD	2	LVC MOS	When left open, LSB of I <sup>2</sup> C slave address is set to "01". When tied to VDD, LSB of I <sup>2</sup> C slave address is set to "10". When tied to GND, LSB of I <sup>2</sup> C slave address is set to "00".
OE	1	LVC MOS	Output Enable (internal pullup). When set to low, output pair is disabled and set at high impedance.
SCL	8	LVC MOS	I <sup>2</sup> C Serial Clock (open-drain). Requires an external pull-up resistor to VDD.
SDA	7	LVC MOS	I <sup>2</sup> C Serial Data (bi-directional, open-drain). Requires an external pull-up resistor to VDD.

## 6 Specifications

### 6.1 Absolute Maximum Ratings

over operating free-air temperature range (unless otherwise noted)<sup>(1)</sup>

		MIN	MAX	UNIT
VDD	Device Supply Voltage	-0.3	3.6	V
V <sub>IN</sub>	Output Voltage Range for Logic Inputs	-0.3	VDD + 0.3	V
V <sub>OUT</sub>	Output Voltage Range for Clock Outputs	-0.3	VDD + 0.3	V
T <sub>J</sub>	Junction Temperature		150	°C
T <sub>STG</sub>	Storage Temperature	-40	125	°C

(1) Stresses beyond those listed under *Absolute Maximum Ratings* may cause permanent damage to the device. These are stress ratings only, which do not imply functional operation of the device at these or any other conditions beyond those indicated under *Recommended Operating Conditions*. Exposure to absolute maximum-rated conditions for extended periods may affect device reliability.

### 6.2 ESD Ratings

		VALUE	UNIT
V <sub>(ESD)</sub>	Electrostatic discharge	Human-body model (HBM), per ANSI/ESDA/JEDEC JS-001 <sup>(1)</sup>	±4000
		Charged-device model (CDM), per JEDEC specification JESD22-C101 <sup>(2)</sup>	±1500

(1) JEDEC document JEP155 states that 500 V HBM allows safe manufacturing with a standard ESD control process.

(2) JEDEC document JEP157 states that 250 V CDM allows safe manufacturing with a standard ESD control process.

### 6.3 Recommended Operating Conditions

over operating free-air temperature range (unless otherwise noted)

		MIN	NOM	MAX	UNIT
VDD	Device Supply Voltage	3.135	3.3	3.465	V
T <sub>A</sub>	Ambient Temperature	-40	25	85	°C
T <sub>J</sub>	Junction Temperature			125	°C
t <sub>RAMP</sub>	VDD Power-Up Ramp Time	0.1		100	ms

### 6.4 Thermal Information

THERMAL METRIC <sup>(1)</sup>	LMK61E2 <sup>(2) (3) (4)</sup>			UNIT	
	QFM (SIA)				
	8 PINS				
	Airflow (LFM) 0	Airflow (LFM) 200	Airflow (LFM) 400		
R <sub>θJA</sub>	Junction-to-ambient thermal resistance	54	44	41.2	°C/W
R <sub>θJC(top)</sub>	Junction-to-case (top) thermal resistance	34	n/a	n/a	
R <sub>θJB</sub>	Junction-to-board thermal resistance	36.7	n/a	n/a	
ψ <sub>JT</sub>	Junction-to-top characterization parameter	11.2	16.9	21.9	
ψ <sub>JB</sub>	Junction-to-board characterization parameter	36.7	37.8	38.9	
R <sub>θJC(bot)</sub>	Junction-to-case (bottom) thermal resistance	n/a	n/a	n/a	

(1) For more information about traditional and new thermal metrics, see the *Semiconductor and IC Package Thermal Metrics* application report, [SPRA953](#).

(2) The package thermal resistance is calculated on a 4 layer JEDEC board.

(3) Connected to GND with 3 thermal vias (0.3-mm diameter).

(4) ψ<sub>JB</sub> (junction to board) is used when the main heat flow is from the junction to the GND pad. Please refer to Thermal Considerations section for more information on ensuring good system reliability and quality.

### 6.5 Electrical Characteristics - Power Supply<sup>(1)</sup>

 VDD = 3.3 V ± 5%, T<sub>A</sub> = -40C to 85°C

PARAMETER	TEST CONDITIONS	MIN	TYP	MAX	UNIT	
IDD	Device Current Consumption	LVPECL <sup>(2)</sup>		162	208	mA
		LVDS		152	196	
		HCSL		155	196	
IDD-PD	Device Current Consumption when output is disabled	OE = GND		136		

(1) Refer to Parameter Measurement Information for relevant test conditions.

(2) On-chip power dissipation should exclude 40 mW, dissipated in the 150 ohm termination resistors, from total power dissipation.

### 6.6 LVPECL Output Characteristics<sup>(1)</sup>

 VDD = 3.3 V ± 5%, T<sub>A</sub> = -40C to 85°C

PARAMETER	TEST CONDITIONS	MIN	TYP	MAX	UNIT
f <sub>OUT</sub>	Output Frequency <sup>(2)</sup>	10		1000	MHz
V <sub>OD</sub>	Output Voltage Swing (V <sub>OH</sub> - V <sub>OL</sub> ) <sup>(2)</sup>	700	800	1200	mV
V <sub>OUT, DIFF, PP</sub>	Differential Output Peak-to-Peak Swing		2 x  V <sub>OD</sub>		V
V <sub>OS</sub>	Output Common Mode Voltage		VDD - 1.55		V
t <sub>R</sub> / t <sub>F</sub>	Output Rise/Fall Time (20% to 80%) <sup>(3)</sup>		120	200	ps
PN-Floor	Output Phase Noise Floor (f <sub>OFFSET</sub> > 10 MHz)	156.25 MHz		-165	dBc/Hz

(1) Refer to Parameter Measurement Information for relevant test conditions.

(2) An output frequency over f<sub>OUT</sub> max spec is possible, but output swing may be less than V<sub>OD</sub> min spec.

(3) Ensured by characterization.

## LVPECL Output Characteristics<sup>(1)</sup> (continued)

VDD = 3.3 V ± 5%, T<sub>A</sub> = -40°C to 85°C

PARAMETER	TEST CONDITIONS	MIN	TYP	MAX	UNIT
ODC	Output Duty Cycle <sup>(3)</sup>	45%		55%	

## 6.7 LVDS Output Characteristics<sup>(1)</sup>

VDD = 3.3 V ± 5%, T<sub>A</sub> = -40°C to 85°C

PARAMETER	TEST CONDITIONS	MIN	TYP	MAX	UNIT
f <sub>OUT</sub>	Output Frequency <sup>(1)</sup>	10		900	MHz
V <sub>OD</sub>	Output Voltage Swing (V <sub>OH</sub> - V <sub>OL</sub> ) <sup>(1)</sup>	300	390	480	mV
V <sub>OUT, DIFF, PP</sub>	Differential Output Peak-to-Peak Swing		2 x  V <sub>OD</sub>		V
V <sub>OS</sub>	Output Common Mode Voltage		1.2		V
t <sub>R</sub> / t <sub>F</sub>	Output Rise/Fall Time (20% to 80%) <sup>(2)</sup>		150	250	ps
PN-Floor	Output Phase Noise Floor (f <sub>OFFSET</sub> > 10 MHz)	156.25 MHz	-162		dBc/Hz
ODC	Output Duty Cycle <sup>(2)</sup>	45%		55%	
R <sub>OUT</sub>	Differential Output Impedance		125		Ohm

(1) An output frequency over f<sub>OUT</sub> max spec is possible, but output swing may be less than V<sub>OD</sub> min spec.

(2) Ensured by characterization.

## 6.8 HCSL Output Characteristics<sup>(1)</sup>

VDD = 3.3 V ± 5%, T<sub>A</sub> = -40°C to 85°C

PARAMETER	TEST CONDITIONS	MIN	TYP	MAX	UNIT
f <sub>OUT</sub>	Output Frequency	10		400	MHz
V <sub>OH</sub>	Output High Voltage	600		850	mV
V <sub>OL</sub>	Output Low Voltage	-100		100	mV
V <sub>CROSS</sub>	Absolute Crossing Voltage <sup>(2)(3)</sup>	250		475	mV
V <sub>CROSS-DELTA</sub>	Variation of V <sub>CROSS</sub> <sup>(2)(3)</sup>	0		140	mV
dV/dt	Slew Rate <sup>(4)</sup>	0.8		2	V/ns
PN-Floor	Output Phase Noise Floor (f <sub>OFFSET</sub> > 10 MHz)	100 MHz	-164		dBc/Hz
ODC	Output Duty Cycle <sup>(4)</sup>	45%		55%	

(1) Refer to Parameter Measurement Information for relevant test conditions.

(2) Measured from -150 mV to +150 mV on the differential waveform with the 300 mVpp measurement window centered on the differential zero crossing.

(3) Ensured by design.

(4) Ensured by characterization.

## 6.9 OE Input Characteristics

VDD = 3.3 V ± 5%, T<sub>A</sub> = -40°C to 85°C

PARAMETER	TEST CONDITIONS	MIN	TYP	MAX	UNIT
V <sub>IH</sub>	Input High Voltage	1.4			V
V <sub>IL</sub>	Input Low Voltage			0.6	V
I <sub>IH</sub>	Input High Current	V <sub>IH</sub> = VDD		40	uA
I <sub>IL</sub>	Input Low Current	V <sub>IL</sub> = GND		40	uA
C <sub>IN</sub>	Input Capacitance		2		pF

## 6.10 ADD Input Characteristics

 $V_{DD} = 3.3\text{ V} \pm 5\%$ ,  $T_A = -40^\circ\text{C}$  to  $85^\circ\text{C}$ 

PARAMETER	TEST CONDITIONS	MIN	TYP	MAX	UNIT
$V_{IH}$	Input High Voltage	1.4			V
$V_{IL}$	Input Low Voltage			0.4	V
$I_{IH}$	Input High Current	$V_{IH} = V_{DD}$		40	$\mu\text{A}$
$I_{IL}$	Input Low Current	$V_{IL} = \text{GND}$		40	$\mu\text{A}$
$C_{IN}$	Input Capacitance		2		pF

## 6.11 Frequency Tolerance Characteristics<sup>(1)</sup>

 $V_{DD} = 3.3\text{ V} \pm 5\%$ ,  $T_A = -40^\circ\text{C}$  to  $85^\circ\text{C}$ 

PARAMETER	TEST CONDITIONS	MIN	TYP	MAX	UNIT
$f_T$	Total Frequency Tolerance	-50		50	ppm

All output formats, frequency bands and device junction temperature up to  $125^\circ\text{C}$ ; includes initial freq tolerance, temperature & supply voltage variation, solder reflow and aging (10 years)

(1) Ensured by characterization.

## 6.12 Power-On/Reset Characteristics (VDD)

 $V_{DD} = 3.3\text{ V} \pm 5\%$ ,  $T_A = -40^\circ\text{C}$  to  $85^\circ\text{C}$ 

PARAMETER	TEST CONDITIONS	MIN	TYP	MAX	UNIT
$V_{THRESH}$	Threshold Voltage <sup>(1)</sup>	2.72		2.95	V
$V_{DROOP}$	Allowable Voltage Droop <sup>(2)</sup>			0.1	V
$t_{STARTUP}$	Startup Time <sup>(1)</sup>	Time elapsed from VDD at 3.135 V to output enabled		10	ms
$t_{OE-EN}$	Output enable time <sup>(2)</sup>	Time elapsed from OE at $V_{IH}$ to output enabled		50	$\mu\text{s}$
$t_{OE-DIS}$	Output disable time <sup>(2)</sup>	Time elapsed from OE at $V_{IL}$ to output disabled		50	$\mu\text{s}$

(1) Ensured by characterization.

(2) Ensured by design.

## 6.13 I<sup>2</sup>C-Compatible Interface Characteristics (SDA, SCL)<sup>(1)(2)</sup>

 $V_{DD} = 3.3\text{ V} \pm 5\%$ ,  $T_A = -40^\circ\text{C}$  to  $85^\circ\text{C}$ 

PARAMETER	TEST CONDITIONS	MIN	TYP	MAX	UNIT	
$V_{IH}$	Input High Voltage	1.2			V	
$V_{IL}$	Input Low Voltage			0.6	V	
$I_{IH}$	Input Leakage	-40		40	$\mu\text{A}$	
$C_{IN}$	Input Capacitance		2		pF	
$C_{OUT}$	Input Capacitance			400	pF	
$V_{OL}$	Output Low Voltage	$I_{OL} = 3\text{ mA}$		0.6	V	
$f_{SCL}$	I <sup>2</sup> C Clock Rate	100		400	kHz	
$t_{SU\_STA}$	START Condition Setup Time	SCL high before SDA low		0.6	$\mu\text{s}$	
$t_{H\_STA}$	START Condition Hold Time	SCL low after SDA low		0.6	$\mu\text{s}$	
$t_{PH\_SCL}$	SCL Pulse Width High			0.6	$\mu\text{s}$	
$t_{PL\_SCL}$	SCL Pulse Width Low			1.3	$\mu\text{s}$	
$t_{H\_SDA}$	SDA Hold Time	SDA valid after SCL low		0	0.9	$\mu\text{s}$
$t_{SU\_SDA}$	SDA Setup Time			115	ns	
$t_{R\_IN} / t_{F\_IN}$	SCL/SDA Input Rise and Fall Time			300	ns	

(1) Total capacitive load for each bus line  $\leq 400\text{ pF}$ .

(2) Ensured by design.

## I<sup>2</sup>C-Compatible Interface Characteristics (SDA, SCL)<sup>(1)(2)</sup> (continued)

VDD = 3.3 V ± 5%, T<sub>A</sub> = -40°C to 85°C

PARAMETER	TEST CONDITIONS	MIN	TYP	MAX	UNIT	
t <sub>F_OUT</sub>	SDA Output Fall Time	C <sub>BUS</sub> = 10 pF to 400 pF			250	ns
t <sub>SU_STOP</sub>	STOP Condition Setup Time	0.6			us	
t <sub>BUS</sub>	Bus Free Time between STOP and START	1.3			us	

### 6.14 Spurious and PSRR Characteristics<sup>(1)</sup>

VDD = 3.3 V, T<sub>A</sub> = 25°C, PLL bandwidth = 400 kHz, VCO Frequency = 5 GHz (Integer-N PLL) or 5.15625 GHz (Fractional-N PLL), Output Divider = 32, Output Type = LVPECL/LVDS/HCSL

PARAMETER	TEST CONDITIONS	MIN	TYP	MAX	UNIT
PSRR	Spurs Induced by 50 mV Power Supply Ripple <sup>(2)(3)</sup> at 156.25 MHz output, all output types	Sine wave at 50 kHz	-70		dBc
		Sine wave at 100 kHz	-70		
		Sine wave at 500 kHz	-70		
		Sine wave at 1 MHz	-70		
SPUR	Max spur power at 156.25 MHz output	All output types			dBc
	Max spur power at 161.1328125 MHz output	All output types			

(1) Refer to Parameter Measurement Information for relevant test conditions.

(2) Measured max spur level with 50 mVpp sinusoidal signal between 50 kHz and 1 MHz applied on VDD pin

(3)  $D_{J_{SPUR}}(ps, pk-pk) = [2 \cdot 10 \cdot (SPUR/20) / (\pi \cdot f_{OUT})] \cdot 1e6$ , where PSRR or SPUR in dBc and f<sub>OUT</sub> in MHz.

### 6.15 Other Characteristics

VDD = 3.3 V ± 5%, T<sub>A</sub> = -40°C to 85°C

PARAMETER	TEST CONDITIONS	MIN	TYP	MAX	UNIT
f <sub>VCO</sub>	VCO Frequency Range	4.6		5.6	GHz

### 6.16 PLL Clock Output Jitter Characteristics<sup>(1)(2)</sup>

VDD = 3.3 V ± 5%, T<sub>A</sub> = -40°C to 85°C

PARAMETER	TEST CONDITIONS	MIN	TYP	MAX	UNIT
RJ	RMS Phase Jitter <sup>(3)</sup> (12 kHz – 20 MHz) (1 kHz – 5 MHz)	f <sub>OUT</sub> ≥ 100 MHz, Integer-N PLL, All output types			fs RMS
RJ	RMS Phase Jitter <sup>(3)</sup> (12 kHz – 20 MHz) (1 kHz – 5 MHz)	f <sub>OUT</sub> ≥ 100 MHz, Fractional-N PLL, All output types			fs RMS

(1) Refer to Parameter Measurement Information for relevant test conditions.

(2) Phase jitter measured with Agilent E5052 signal source analyzer using a differential-to-single ended converter (balun or buffer).

(3) Ensured by characterization.

### 6.17 Typical 156.25 MHz Output Phase Noise Characteristics<sup>(1)(2)</sup>

VDD = 3.3 V, T<sub>A</sub> = 25°C, PLL bandwidth = 400 kHz, VCO Frequency = 5 GHz, Integer-N PLL, Output Divider = 32, Output Type = LVPECL/LVDS/HCSL

SYMBOL	PARAMETER	OUTPUT TYPE			UNITS
		LVPECL	LVDS	HCSL	
phn <sub>10k</sub>	Phase noise at 10 kHz offset	-143	-143	-143	dBc/Hz
Phn <sub>20k</sub>	Phase noise at 20 kHz offset	-143	-143	-143	dBc/Hz
phn <sub>100k</sub>	Phase noise at 100 kHz offset	-144	-144	-144	dBc/Hz
Phn <sub>200k</sub>	Phase noise at 200 kHz offset	-145	-145	-145	dBc/Hz

(1) Refer to Parameter Measurement Information for relevant test conditions.

(2) Phase jitter measured with Agilent E5052 signal source analyzer using a differential-to-single ended converter (balun or buffer).

**Typical 156.25 MHz Output Phase Noise Characteristics<sup>(1)(2)</sup> (continued)**

VDD = 3.3 V, T<sub>A</sub> = 25°C, PLL bandwidth = 400 kHz, VCO Frequency = 5 GHz, Integer-N PLL, Output Divider = 32, Output Type = LVPECL/LVDS/HCSL

SYMBOL	PARAMETER	OUTPUT TYPE			UNITS
		LVPECL	LVDS	HCSL	
phn <sub>1M</sub>	Phase noise at 1 MHz offset	-150	-150	-150	dBc/Hz
phn <sub>2M</sub>	Phase noise at 2 MHz offset	-154	-154	-154	dBc/Hz
phn <sub>10M</sub>	Phase noise at 10 MHz offset	-165	-162	-164	dBc/Hz
phn <sub>20M</sub>	Phase noise at 20 MHz offset	-165	-162	-164	dBc/Hz

**6.18 Typical 161.1328125 MHz Output Phase Noise Characteristics<sup>(1)(2)</sup>**

VDD = 3.3 V, T<sub>A</sub> = 25°C, PLL bandwidth = 400 kHz, VCO Frequency = 5.15625 GHz, Fractional-N PLL, Output Divider = 32, Output Type = LVPECL/LVDS/HCSL

SYMBOL	PARAMETER	OUTPUT TYPE			UNITS
		LVPECL	LVDS	HCSL	
phn <sub>10k</sub>	Phase noise at 10 kHz offset	-136	-136	-136	dBc/Hz
phn <sub>20k</sub>	Phase noise at 20 kHz offset	-136	-136	-136	dBc/Hz
phn <sub>100k</sub>	Phase noise at 100 kHz offset	-140	-140	-140	dBc/Hz
phn <sub>200k</sub>	Phase noise at 200 kHz offset	-141	-141	-141	dBc/Hz
phn <sub>1M</sub>	Phase noise at 1 MHz offset	-148	-148	-148	dBc/Hz
phn <sub>2M</sub>	Phase noise at 2 MHz offset	-156	-156	-156	dBc/Hz
phn <sub>10M</sub>	Phase noise at 10 MHz offset	-161	-159	-160	dBc/Hz
phn <sub>20M</sub>	Phase noise at 20 MHz offset	-162	-160	-161	dBc/Hz

(1) Refer to Parameter Measurement Information for relevant test conditions.

(2) Phase jitter measured with Agilent E5052 signal source analyzer using a differential-to-single ended converter (balun or buffer).

**6.19 Additional Reliability and Qualification**

PARAMETER	CONDITION / TEST METHOD
Mechanical Shock	MIL-STD-202, Method 213
Mechanical Vibration	MIL-STD-202, Method 204
Moisture Sensitivity Level	J-STD-020, MSL3

## 6.20 Typical Performance Characteristics

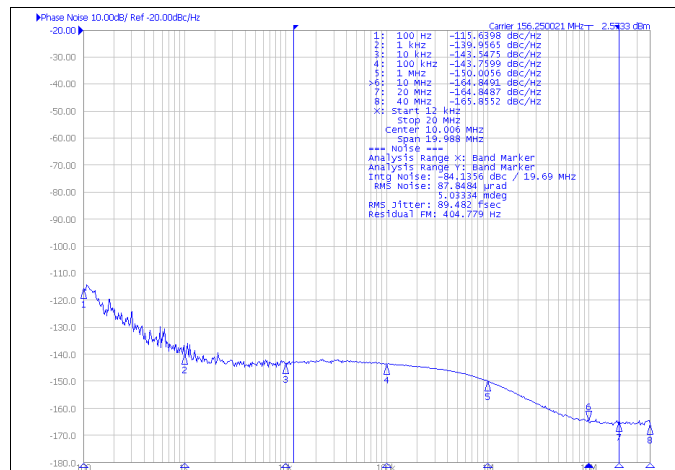

Figure 1. Closed Loop Phase Noise of LVPECL Differential Output at 156.25 MHz with PLL bandwidth at 400 kHz, Integer-N PLL, 5 GHz VCO Frequency, Output Divider = 32

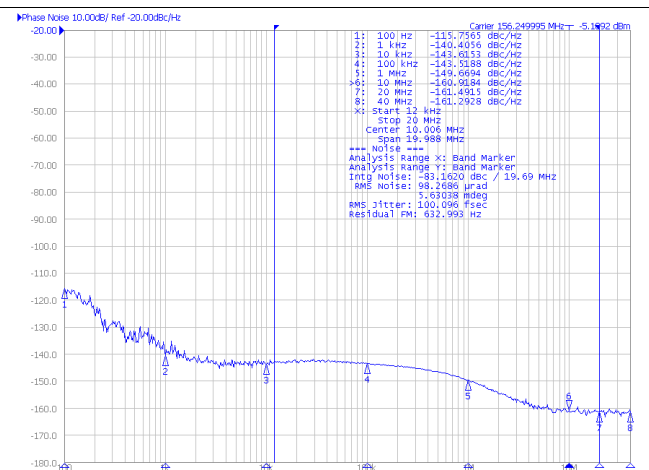

Figure 2. Closed Loop Phase Noise of LVDS Differential Output at 156.25 MHz with PLL bandwidth at 400 kHz, Integer-N PLL, 5 GHz VCO Frequency, Output Divider = 32

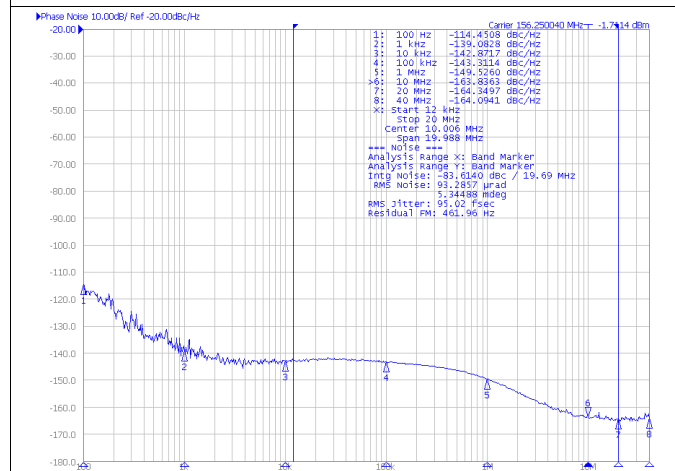

Figure 3. Closed Loop Phase Noise of HCMSEL Differential Output at 156.25 MHz with PLL bandwidth at 400 kHz, Integer-N PLL, 5 GHz VCO Frequency, Output Divider = 32

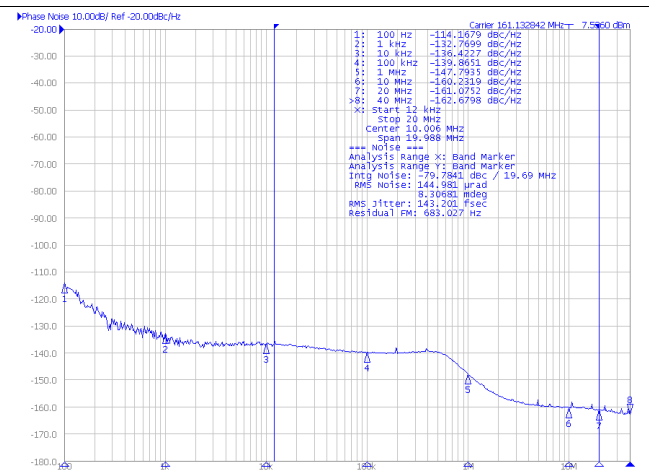

Figure 4. Closed Loop Phase Noise of LVPECL Differential Output at 161.1328125 MHz with PLL Bandwidth at 400 kHz, Fractional-N PLL, 5.15625 GHz VCO Frequency, Output Divider = 32

Typical Performance Characteristics (continued)

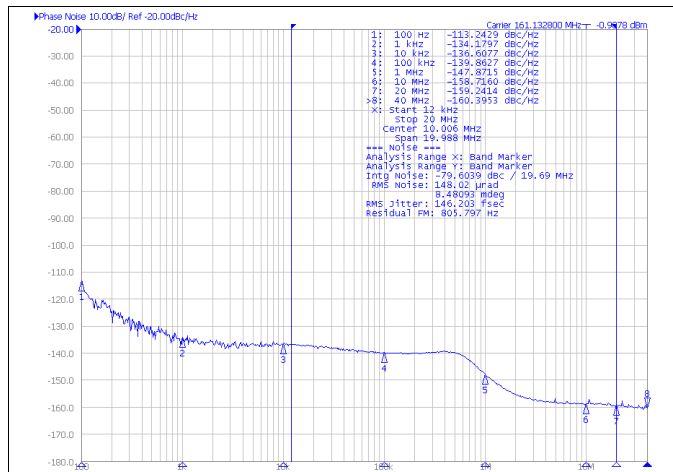

Figure 5. Closed Loop Phase Noise of LVDS Differential Output at 161.1328125 MHz with PLL bandwidth at 400 kHz, Fractional-N PLL, 5.15625 GHz VCO Frequency, Output Divider = 32

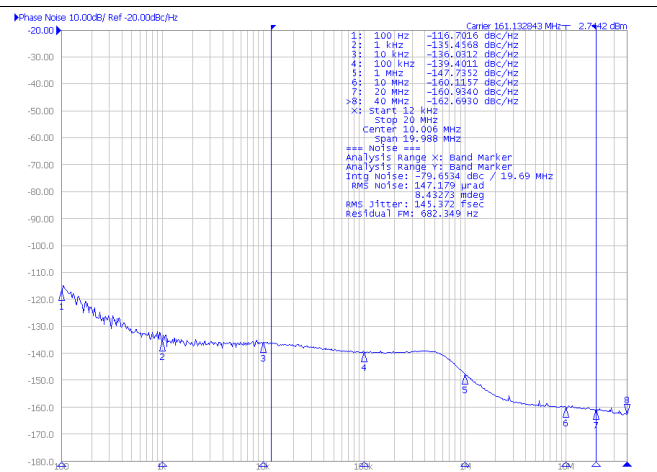

Figure 6. Closed Loop Phase Noise of HCSL Differential Output at 161.1328125 MHz with PLL bandwidth at 400 kHz, Fractional-N PLL, 5.15625 GHz VCO Frequency, Output Divider = 32

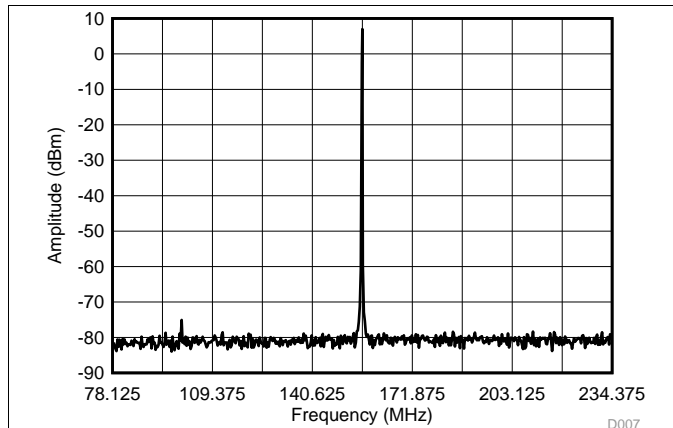

Figure 7. 156.25 ± 78.125 MHz LVPECL Differential Output Spectrum with PLL bandwidth at 400 kHz, Integer-N PLL, 5 GHz VCO Frequency, Output Divider = 32

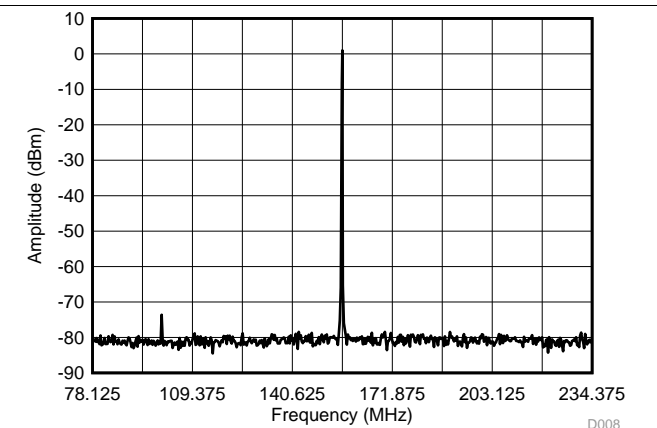

Figure 8. 156.25 ± 78.125 MHz LVDS Differential Output Spectrum with PLL bandwidth at 400 kHz, Integer-N PLL, 5 GHz VCO Frequency, Output Divider = 32

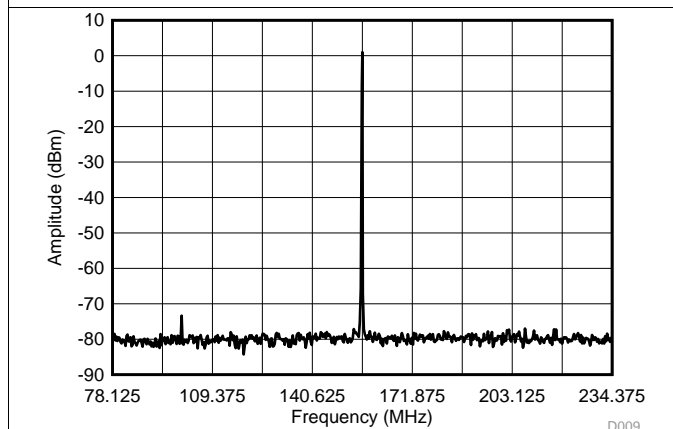

Figure 9. 156.25 ± 78.125 MHz HCSL Differential Output Spectrum with PLL bandwidth at 400 kHz, Integer-N PLL, 5 GHz VCO Frequency, Output Divider = 32

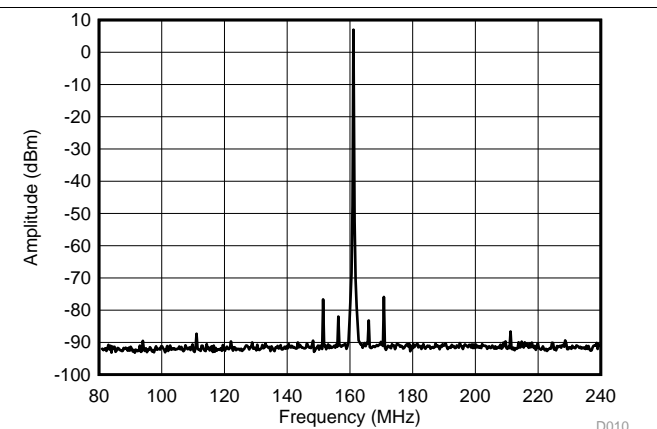
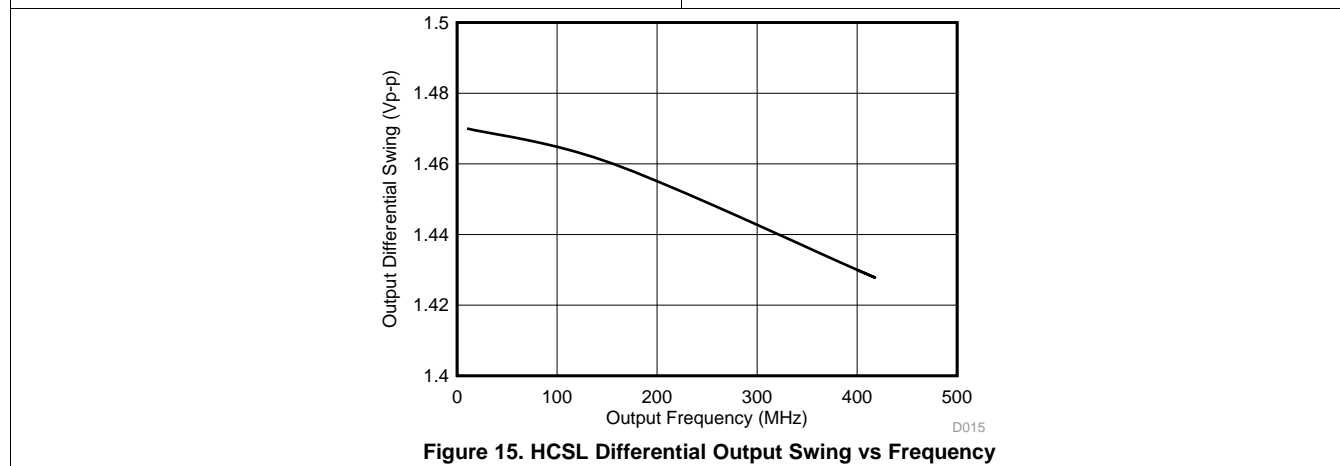
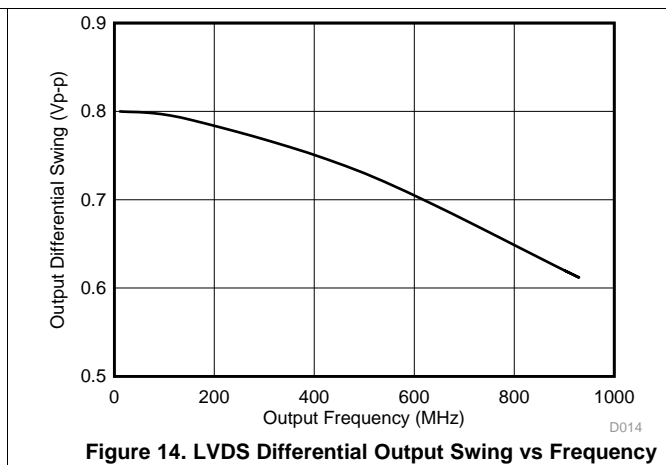
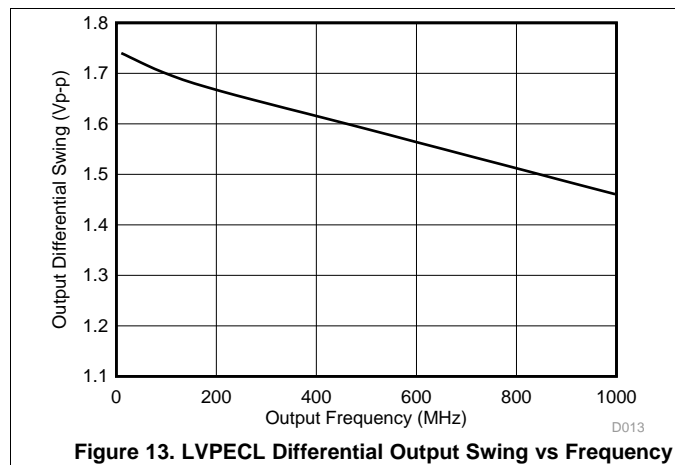
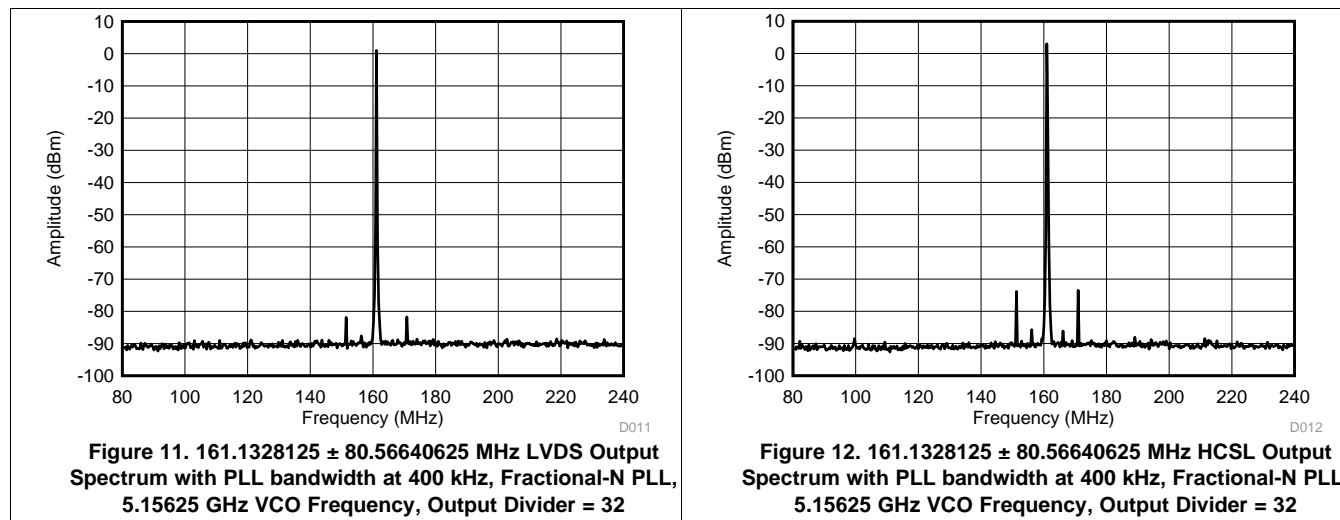

Figure 10. 161.1328125 ± 80.56640625 MHz LVPECL Differential Output Spectrum with PLL bandwidth at 400 kHz, Fractional-N PLL, 5.15625 GHz VCO Frequency, Output Divider = 32

Typical Performance Characteristics (continued)



## 7 Parameter Measurement Information

### 7.1 Device Output Configurations

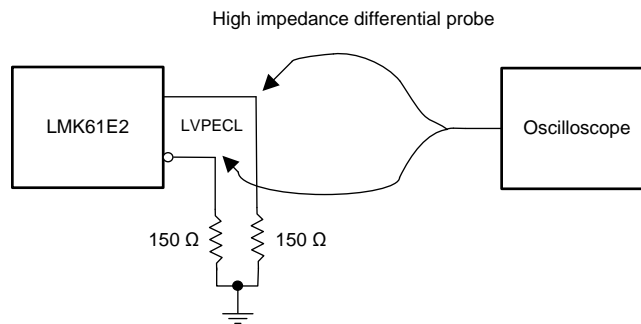

Figure 16. LVPECL Output DC Configuration during Device Test

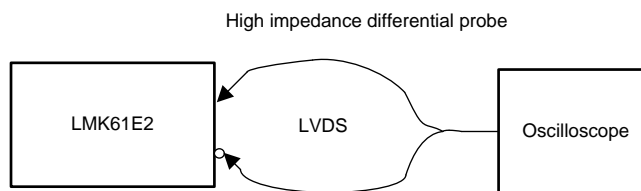

Figure 17. LVDS Output DC Configuration during Device Test

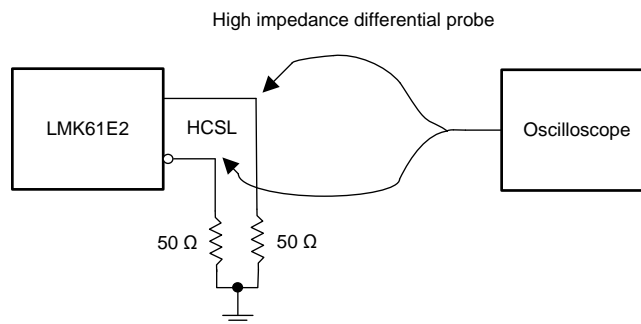

Figure 18. HCSL Output DC Configuration during Device Test

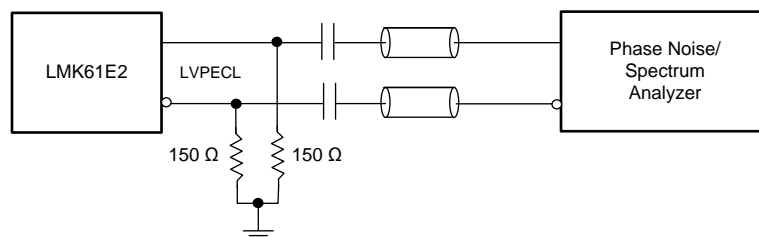

Figure 19. LVPECL Output AC Configuration during Device Test

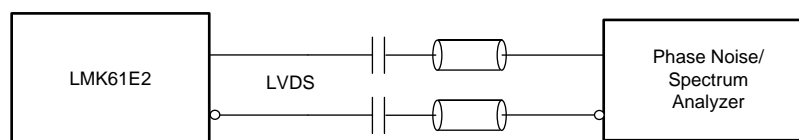

Figure 20. LVDS Output AC Configuration during Device Test

Device Output Configurations (continued)

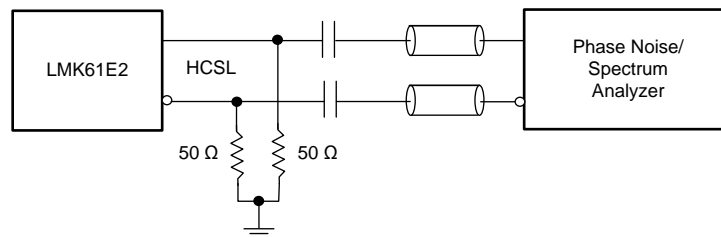

Figure 21. HCSL Output AC Configuration during Device Test

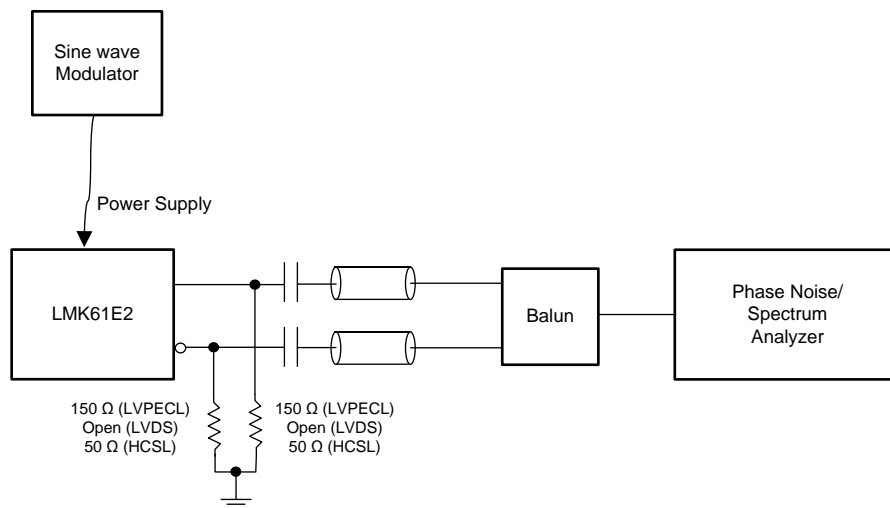

Figure 22. PSRR Test Setup

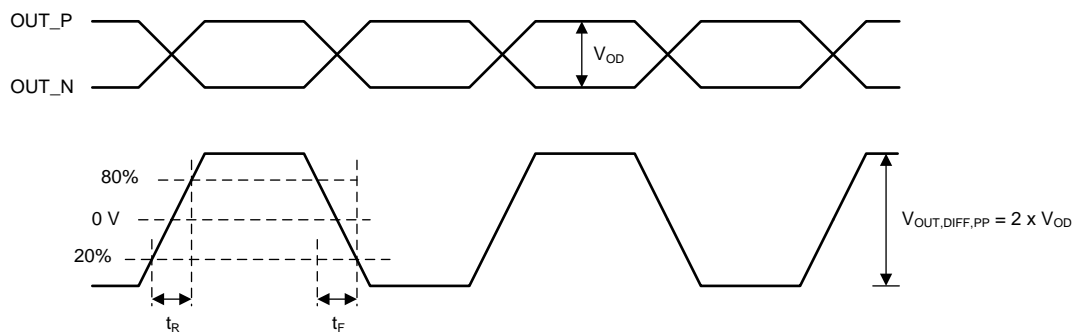

Figure 23. Differential Output Voltage and Rise/Fall Time

## 8 Detailed Description

### 8.1 Overview

The LMK61E2 is a programmable oscillator that generates commonly used reference clocks with less than 200 fs, rms max random jitter in integer PLL mode and less than 300 fs, rms max random jitter in fractional PLL mode.

### 8.2 Functional Block Diagram

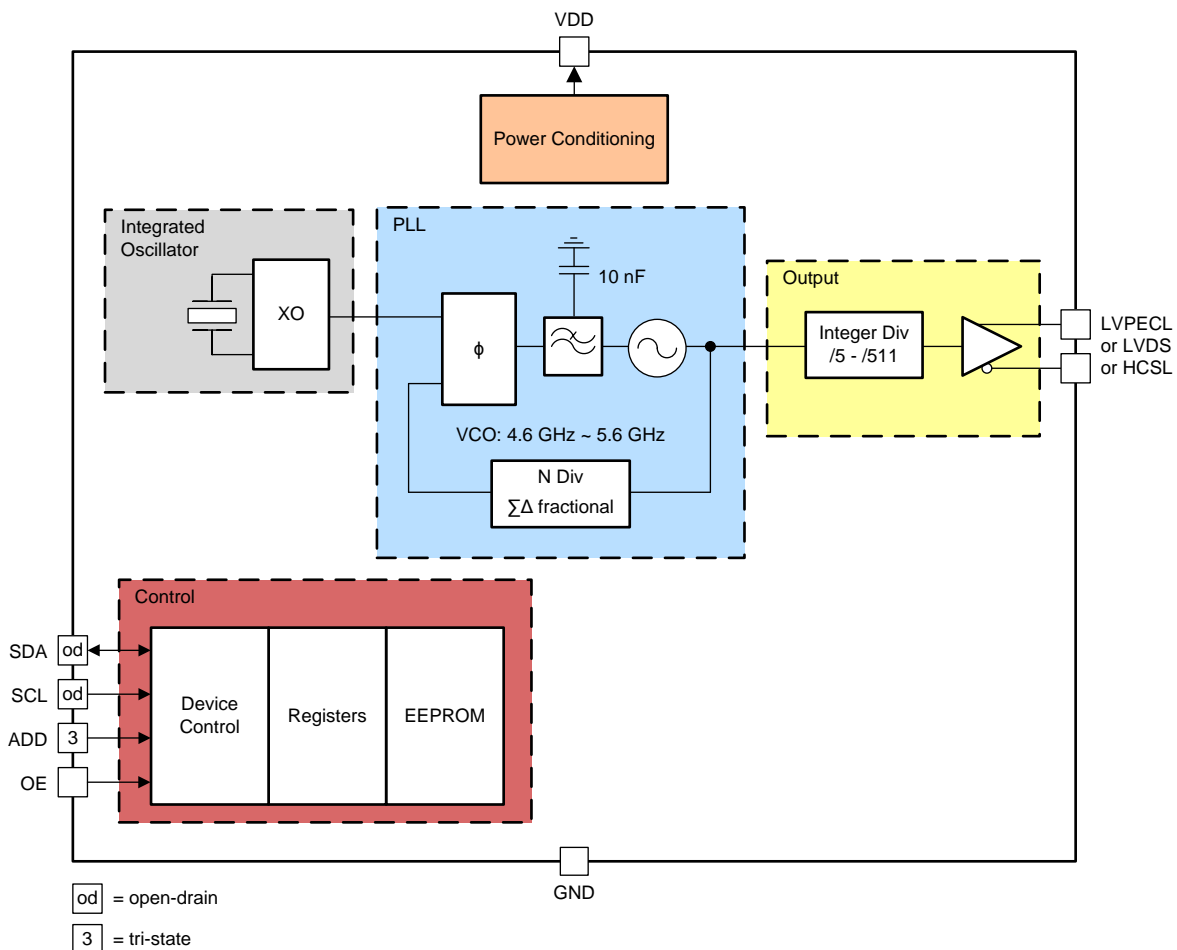

#### NOTE

Control blocks are compatible with 1.8/2.5/3.3 V I/O voltage levels.

### 8.3 Feature Description

#### 8.3.1 Device Block-Level Description

The LMK61E2 comprises of an integrated oscillator that includes a 50 MHz crystal, a fractional PLL with integrated VCO that supports a frequency range of 4.6 GHz to 5.6 GHz. The PLL block consists of a phase frequency detector (PFD), charge pump, integrated passive loop filter, a feedback divider that can support both integer and fractional values and a delta-sigma engine for noise suppression in fractional PLL mode. Completing the device is the combination of an integer output divider and a universal differential output buffer. The PLL is powered by on-chip low dropout (LDO) linear voltage regulators and the regulated supply network is partitioned

## Feature Description (continued)

such that the sensitive analog supplies are running from separate LDOs than the digital supplies which use their own LDO. The LDOs provide isolation to the PLL from any noise in the external power supply rail with a PSRR of better than -70 dBc at 50 kHz to 1 MHz ripple frequencies at 3.3 V device supply. The device supports fine and coarse frequency margining by changing the settings of the integrated oscillator and the output divider respectively.

### 8.3.2 Device Configuration Control

The LMK61E2 supports I<sup>2</sup>C programming interface where an I<sup>2</sup>C host can update any device configuration after the device enables the host interface and the host writes a sequence that updates the device registers. Once the device configuration is set, the host can also write to the on-chip EEPROM for a new set of powerup defaults based on the configuration pin settings in the soft pin configuration mode.

### 8.3.3 Register File Reference Convention

Figure 24 shows the method that this document employs to refer to an individual register bit or a grouping of register bits. If a drawing or text references an individual bit the format is to specify the register number first and the bit number second. The LMK61E2 contains 38 registers that are 8 bits wide. The register addresses and the bit positions both begin with the number zero (0). A period separates the register address and bit address. The first bit in the register file is address 'R0.0' meaning that it is located in Register 0 and is bit position 0. The last bit in the register file is address 'R31.7' referring to the 8th bit of register address 31 (the 32nd register in the device). Figure 24 also lists specific bit positions as a number contained within a box. A box with the register address encloses the group of boxes that represent the bits relevant to the specific device circuitry in context.

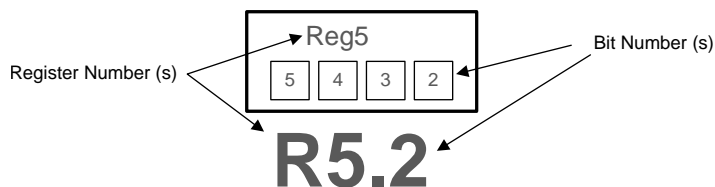

Figure 24. LMK61E2 Register Reference Format

### 8.3.4 Configuring the PLL

The PLL in LMK61E2 can be configured to accommodate various output frequencies either through I<sup>2</sup>C programming interface or in the absence of programming, the PLL defaults stored in EEPROM is loaded on powerup. The PLL can be configured by setting the Reference Doubler, Integrated PLL Loop Filter, Feedback Divider, and Output Divider.

For the PLL to operate in closed loop mode, the following condition in Equation 1 has to be met.

$$F_{VCO} = F_{REF} \times D \times [(INT + NUM/DEN)]$$

where

- F<sub>VCO</sub>: PLL/VCO Frequency (4.6 GHz to 5.6 GHz)
- F<sub>REF</sub>: 50 MHz reference input
- D: PLL input frequency doubler, 1=Disabled, 2=Enabled
- INT: PLL feedback divider integer value (12 bits, 1 to 4095)
- NUM: PLL feedback divider fractional numerator value ( 22 bits, 0 to 4194303)
- DEN: PLL feedback divider fractional denominator value ( 22 bits, 1 to 4194303)

The output frequency is related to the VCO frequency as given in Equation 2.

$$F_{OUT} = F_{VCO} / OUTDIV$$

where

- OUTDIV: Output divider value (9 bits, 5 to 511)

## Feature Description (continued)

### 8.3.5 Integrated Oscillator

The integrated oscillator in LMK61E2 features programmable load capacitances that can be set to either operate at exactly its nominal oscillation frequency or operate at a fixed frequency offset from its nominal oscillation frequency. This is done by programming R16 and R17. More details on frequency margining are provided in [Fine Frequency Margining](#).

### 8.3.6 Reference Doubler

The reference path has a frequency doubler that can be enabled by programming R34.5 = “1”. Enabling the doubler allows a higher comparison frequency for the PLL and would result in a 3 dB reduction in the in-band phase noise at the output of the LMK61E2. Enabling the doubler also results in higher reference and phase detector spurs which will be minimized by enabling the higher order components (R3, C3) of the loop filter and programmed to appropriate values. Disabling the doubler would result in higher in-band phase noise on the device output than when the doubler is enabled but the reference and phase detector spurs would be lower on the device output than when the doubler is enabled.

### 8.3.7 Phase Frequency Detector

The PFD of the PLL takes inputs from the reference path and the feedback divider output and produces an output that is dependent on the phase and frequency difference between the two inputs. The allowable range of frequencies at the inputs of the PFD is 50 MHz, when reference doubler is disabled, or 100 MHz, when reference doubler is enabled.

### 8.3.8 Feedback Divider (N)

The N divider of the PLL includes fractional compensation and can achieve any fractional denominator (DEN) from 1 to 4,194,303. The integer portion, INT, is the whole part of the N divider value and the fractional portion, NUM / DEN, is the remaining fraction. N, NUM, and DEN are programmed in R25, R26, R27, R28, R29, R30, R31, and R32. The total programmed N divider value, N, is determined by:  $N = INT + NUM / DEN$ . The output of the N divider sets the PFD frequency to the PLL and should equal 50 MHz, when reference doubler is disabled, or 100 MHz, when reference doubler is enabled.

### 8.3.9 Fractional Circuitry

The delta signal modulator is a key component of the fractional circuitry and is involved in noise shaping for better phase noise and spurs in the band of interest. The order of the delta sigma modulator is selectable between integer mode and third order, for fractional PLL mode, and can be programmed in R33[1-0]. The dithering mode is selectable between disabled, for integer PLL mode, and weak, for fractional PLL mode, and can be programmed in R33[3-2].

### 8.3.10 Charge Pump

The PLL has charge pump slices of 1.6 mA, to be used when PLL is set to fractional mode, or 6.4 mA, to be used when PLL is set to integer mode. These slices can be selected by programming R34[3-0]. When PLL is set to fractional mode, a phase shift needs to be introduced to ensure consistent performance across operating conditions and a value of “010” should be programmed in R35[6-4]. When PLL is set to integer mode, a value of “000” should be programmed in R35[6-4].

### 8.3.11 Loop Filter

The LMK61E2 features a fully integrated loop filter for the PLL and supports programmable loop bandwidth from 100 kHz to 1 MHz. The loop filter components, R2, C1, R3, C3, can be configured by programming R36, R37, R38 and R39 respectively. The LMK61E2 features a fixed value of C2 of 10 nF. When PLL is configured in the fractional mode, R35.2 should be set to “1”. When reference doubler is disabled for integer mode PLL, R35.2 should be set to “0” and R38[6-0] should be set to “0000000”. When reference doubler is enabled for integer mode PLL, R35.2 should be set to “1” and R38 and R39 are written with the appropriate values. [Figure 25](#) shows the loop filter structure of the PLL. It is important to set the PLL to best possible bandwidth to minimize output jitter. TI provides the WEBENCH Clock Architect Tool that makes it easy to select the right loop filter components.

## Feature Description (continued)

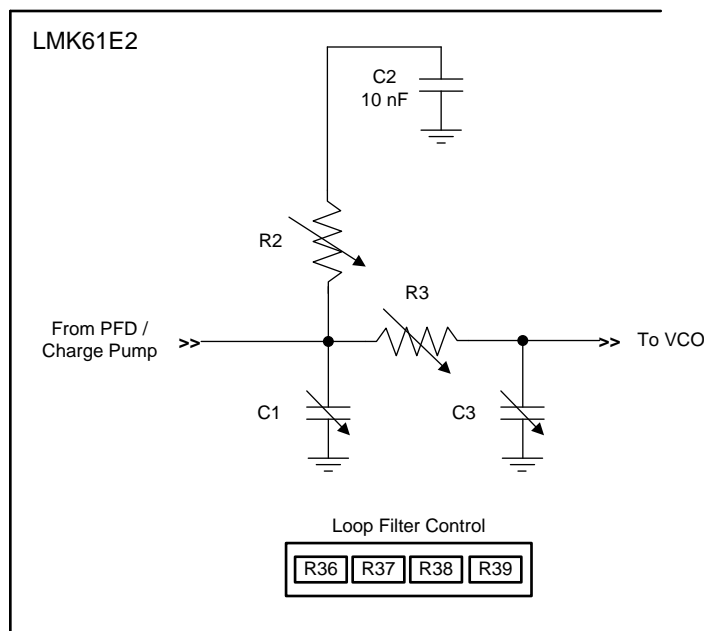

Figure 25. Loop Filter Structure of PLL

### 8.3.12 VCO Calibration

The PLL in LMK61E2 is made of LC VCO that is designed using high-Q monolithic inductors to oscillate between 4.6 GHz and 5.6 GHz and has low phase noise characteristics. The VCO must be calibrated to ensure that the clock outputs deliver optimal phase noise performance. Fundamentally, a VCO calibration establishes an optimal operating point within the tuning range of the VCO. Setting R72.1 to “1” causes a VCO recalibration and is necessary after device reconfiguration. VCO calibration automatically occurs on device power up.

### 8.3.13 High-Speed Output Divider

The high-speed output divider supports divide values of 5 to 511 and are programmed in R22 and R23. The output divider also supports coarse frequency margining that can initiate as low as a 5% change in the output frequency.

### 8.3.14 High-Speed Clock Output

The clock output can be configured as LVPECL, LVDS, or HCSL by programming R21.1 and R21.0. Interfacing to LVPECL, LVDS, or HCSL receivers are done either with direct coupling or with AC-coupling capacitor as shown in [Figure 3](#) - [Figure 8](#).

The LVDS output structure has integrated 125 ohm termination between each side (P and N) of the differential pair. The HCSL output structure is open drain and can be DC or AC coupled to HCSL receivers with appropriate termination scheme. The LVPECL output structure is an emitter follower requiring external termination.

### 8.3.15 Device Status

The PLL loss of lock and PLL calibration status can be monitored by reading R66.1 and R66.0. These bits represent a logic-high interrupt output and are self-cleared once the readback is complete.

#### 8.3.15.1 Loss of Lock

The PLL loss of lock detection circuit is a digital circuit that detects any frequency error, even a single cycle slip. Loss of lock may occur when an incorrect PLL configuration is programmed or the VCO has not been recalibrated.

## 8.4 Device Functional Modes

### 8.4.1 Interface and Control

The host (DSP, Microcontroller, FPGA, etc) configures and monitors the LMK61E2 via the I<sup>2</sup>C port. The host reads and writes to a collection of control/status bits called the register map. The device blocks can be controlled and monitored via a specific grouping of bits located within the register file. The host controls and monitors certain device Wide critical parameters directly via register control/status bits. In the absence of the host, the LMK61E2 can be configured to operate from its on-chip EEPROM. The EEPROM array is automatically copied to the device registers upon powerup. The user has the flexibility to re Write the contents of EEPROM from the SRAM up to a 100 times.

Within the device registers, there are certain bits that have read/write access. Other bits are read-only (an attempt to write to a read only bit will not change the state of the bit). Certain device registers and bits are reserved meaning that they must not be changed from their default reset state. Figure 28 shows interface and control blocks within LMK61E2 and the arrows refer to read access from and write access to the different embedded memories (EEPROM, SRAM).

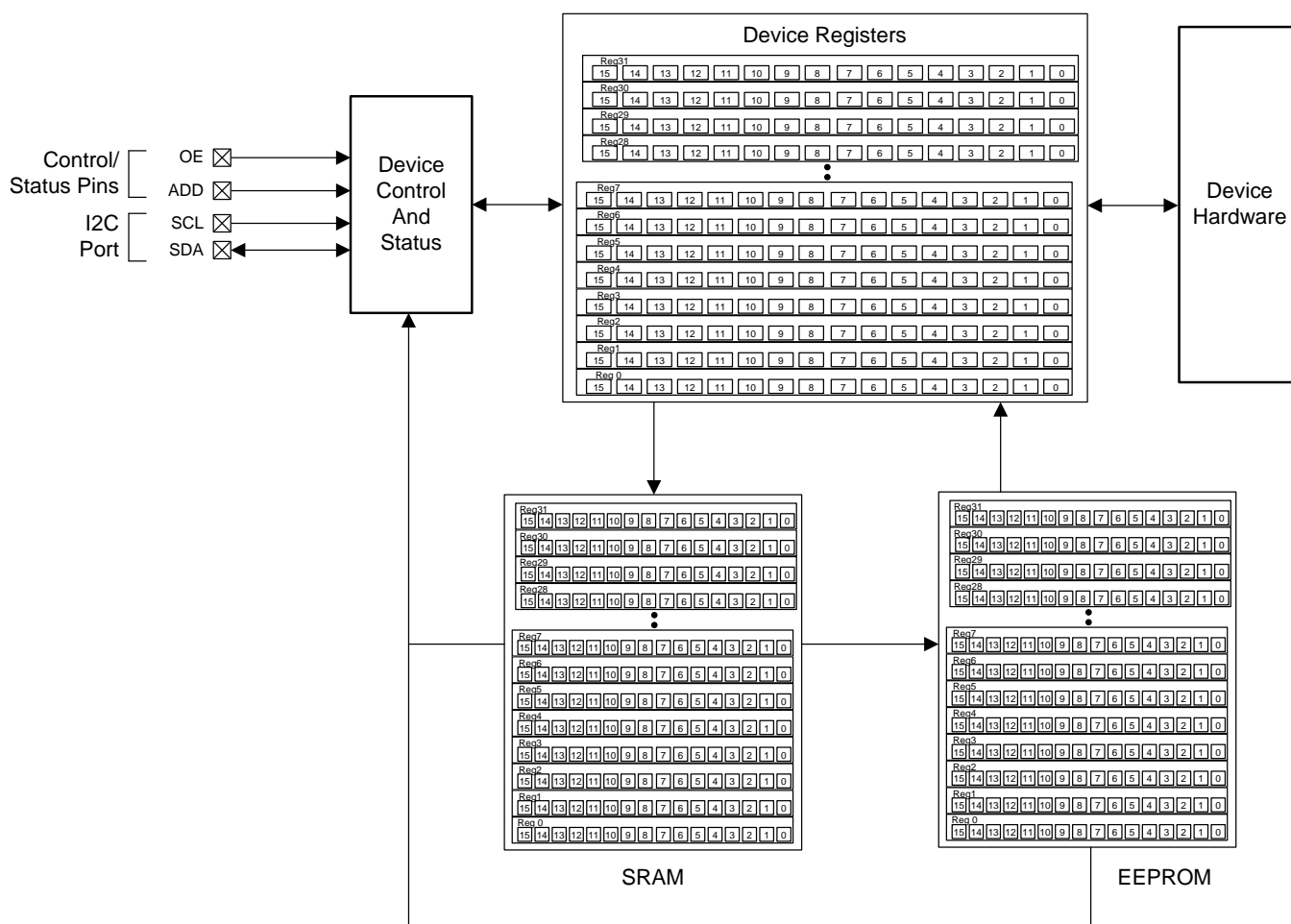

Figure 26. LMK61E2 Interface and Control Block

## 8.5 Programming

### 8.5.1 I<sup>2</sup>C Serial Interface

The I<sup>2</sup>C port on the LMK61E2 works as a slave device and supports both the 100 kHz standard mode and 400 kHz fast mode operations. Fast mode imposes a glitch tolerance requirement on the control signals. Therefore, the input receivers ignore pulses of less than 50 ns duration. The I<sup>2</sup>C timing is given in Table 4. The timing diagram is given in Figure 27.

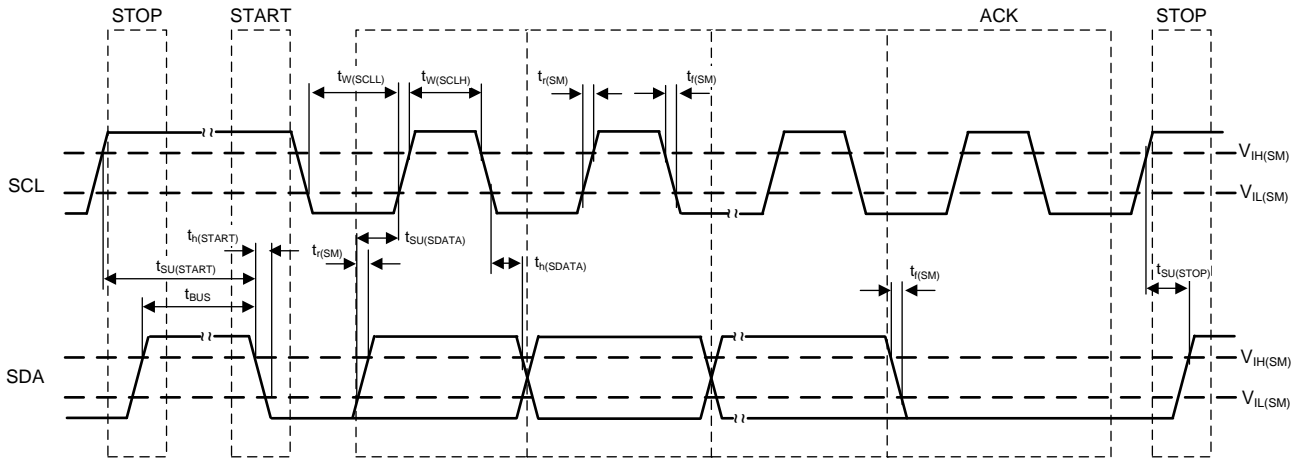

Figure 27. I<sup>2</sup>C Timing Diagram

In an I<sup>2</sup>C bus system, the LMK61E2 acts as a slave device and is connected to the serial bus (data bus SDA and lock bus SCL). These are accessed via a 7-bit slave address transmitted as part of an I<sup>2</sup>C packet. Only the device with a matching slave address responds to subsequent I<sup>2</sup>C commands. In soft pin mode, the LMK61E2 allows up to three unique slave devices to occupy the I<sup>2</sup>C bus based on the pin strapping of ADD (tied to VDD, GND or left open). The device slave address is 10110xx (the two LSBs are determined by the ADD pin).

During the data transfer through the I<sup>2</sup>C interface, one clock pulse is generated for each data bit transferred. The data on the SDA line must be stable during the high period of the clock. The high or low state of the data line can change only when the clock signal on the SCL line is low. The start data transfer condition is characterized by a high-to-low transition on the SDA line while SCL is high. The stop data transfer condition is characterized by a low-to-high transition on the SDA line while SCL is high. The start and stop conditions are always initiated by the master. Every byte on the SDA line must be eight bits long. Each byte must be followed by an acknowledge bit and bytes are sent MSB first. The I<sup>2</sup>C register structure of the LMK61E2 is shown in Figure 28.

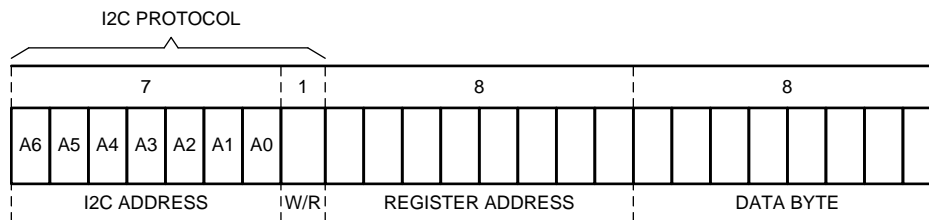

Figure 28. I<sup>2</sup>C Register Structure

The acknowledge bit (A) or non-acknowledge bit (A') is the 9th bit attached to any 8-bit data byte and is always generated by the receiver to inform the transmitter that the byte has been received (when A = 0) or not (when A' = 0). A = 0 is done by pulling the SDA line low during the 9th clock pulse and A' = 0 is done by leaving the SDA line high during the 9th clock pulse.

## Programming (continued)

The I<sup>2</sup>C master initiates the data transfer by asserting a start condition which initiates a response from all slave devices connected to the serial bus. Based on the 8-bit address byte sent by the master over the SDA line (consisting of the 7-bit slave address (MSB first) and an R/W' bit), the device whose address corresponds to the transmitted address responds by sending an acknowledge bit. All other devices on the bus remain idle while the selected device waits for data transfer with the master.

After the data transfer has occurred, stop conditions are established. In write mode, the master asserts a stop condition to end data transfer during the 10th clock pulse following the acknowledge bit for the last data byte from the slave. In read mode, the master receives the last data byte from the slave but does not pull SDA low during the 9th clock pulse. This is known as a non-acknowledge bit. By receiving the non-acknowledge bit, the slave knows the data transfer is finished and enters the idle mode. The master then takes the data line low during the low period before the 10th clock pulse, and high during the 10th clock pulse to assert a stop condition. A generic transaction is shown in [Figure 29](#).

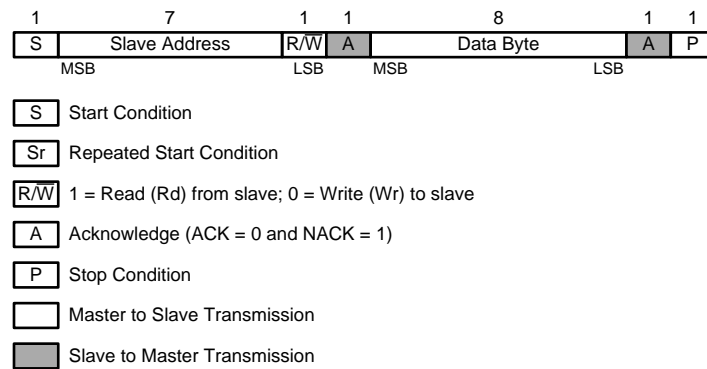

**Figure 29. Generic Programming Sequence**

The LMK61E2 I<sup>2</sup>C interface supports “Block Register Write/Read”, “Read/Write SRAM”, and “Read/Write EEPROM” operations. For “Block Register Write/Read” operations, the I<sup>2</sup>C master can individually access addressed registers that are made of an 8-bit data byte. The offset of the indexed register is encoded in the register address, as described in [Table 1](#) below.

**Table 1. Slave Address Byte**

DEVICE	A6	A5	A4	A3	A2	ADD	R/W
LMK61E2	1	0	1	1	0	00, 01 or 10	1/0

### 8.5.2 Block Register Write

The I<sup>2</sup>C “Block Register Write” transaction is illustrated in [Figure 30](#) and consists of the following sequence.

1. Master issues a Start Condition.
2. Master writes the 7-bit Slave Address following by a Write bit.
3. Master writes the 8-bit Register address as the CommandCode of the programming sequence.
4. Master writes one or more data bytes each of which should be acknowledged by the slave. The slave increments the internal register address after each byte.
5. Master issues a Stop Condition to terminate the transaction.

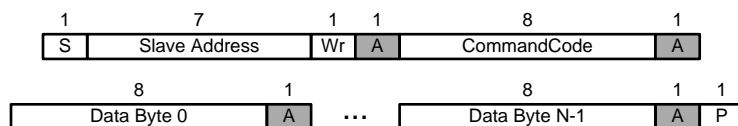
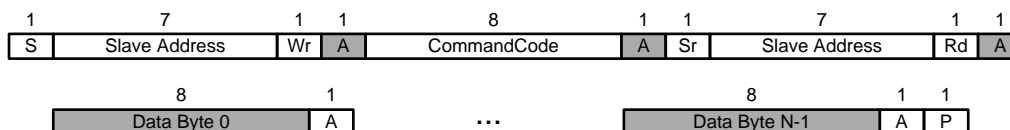

**Figure 30. “Block Register Write” Programming Sequence**

### 8.5.3 Block Register Read

The I<sup>2</sup>C “Block Register Read” transaction is illustrated in [Figure 31](#) and consists of the following sequence.

1. Master issues a Start Condition.
2. Master writes the 7-bit Slave Address followed by a Write bit.
3. Master writes the 8-bit Register address as the CommandCode of the programming sequence.
4. Master issues a Repeated Start Condition.
5. Master writes the 7-bit Slave Address following by a Read bit.
6. Slave returns one or more data bytes as long as the Master continues to acknowledge them. The slave increments the internal register address after each byte.
7. Master issues a Stop Condition to terminate the transaction.



**Figure 31. “Block Register Read” Programming Sequence**

### 8.5.4 Write SRAM

The on-chip SRAM is a volatile, shadow memory array used to temporarily store register data, and is intended only for programming the non Volatile EEPROM. The SRAM has the identical data format as the EEPROM map. The register configuration data can be transferred to the SRAM array through special memory access registers in the register map. In order to successfully program the SRAM, the complete base array and at least one page should be written. The following details the programming sequence to transfer the device registers into the SRAM.

1. Program the device registers to match a desired setting.
2. Write a “1” to R49.6. This ensures that the device registers are copied to the SRAM.

The SRAM can also be written with particular values according to the following programming sequence.

1. Write the SRAM address in R51.
2. Write the desired data byte in R53 in the same I<sup>2</sup>C transaction and this data byte will be written to the address specified in the step above. Any additional access that is part of the same transaction will cause the SRAM address to be incremented and a write will take place to the next SRAM address. Access to SRAM will terminate at the end of current I<sup>2</sup>C transaction.

#### NOTE

It is possible to increment SRAM address incorrectly when 2 successive accesses are made to R51.

### 8.5.5 Write EEPROM

The on-chip EEPROM is a non Volatile memory array used to permanently store register data for a custom device start-up configuration setting to initialize registers upon power-up or POR. The EEPROM is comprised of bits shown in the EEPROM Map. The transfer must first happen to the SRAM and then to the EEPROM. During “EEPROM write”, R49.2 is a “1” and the EEPROM contents cannot be accessed. The following details the programming sequence to transfer the entire contents of SRAM to EEPROM.

1. Make sure the “Write SRAM” procedure (Write SRAM) was done to commit the register settings to the SRAM with start-up configurations intended for programming to the EEPROM.
2. Write “0xBE” to R56. This provides basic protection from inadvertent programming of EEPROM.
3. Write a “1” to R49.0. This programs the entire SRAM contents to EEPROM. Once completed, the contents in R48 will increment by 1. R48 contains the total number of EEPROM programming cycles that are successfully completed.
4. Write “0x00” to R56 to protect against inadvertent programming of EEPROM.

### 8.5.6 Read SRAM

The contents of the SRAM can be read out, one word at a time, starting with that of the requested address. Following details the programming sequence for an SRAM read by address.

1. Write the SRAM address in R51.
2. The SRAM data located at the address specified in the step above can be obtained by reading R53 in the same I<sup>2</sup>C transaction. Any additional access that is part of the same transaction will cause the SRAM address to be incremented and a read will take place of the next SRAM address. Access to SRAM will terminate at the end of current I<sup>2</sup>C transaction.

---

#### NOTE

It is possible to increment SRAM address incorrectly when 2 successive accesses are made to R51.

---

### 8.5.7 Read EEPROM

The contents of the EEPROM can be read out, one word at a time, starting with that of the requested address. Following details the programming sequence for an EEPROM read by address.

1. Write the EEPROM address in R51.
2. The EEPROM data located at the address specified in the step above can be obtained by reading R52 in the same I<sup>2</sup>C transaction. Any additional access that is part of the same transaction will cause the EEPROM address to be incremented and a read will take place of the next EEPROM address. Access to EEPROM will terminate at the end of current I<sup>2</sup>C transaction.

---

#### NOTE

It is possible to increment EEPROM address incorrectly when 2 successive accesses are made to R51.

---

## 8.6 Register Map

Name	Addr	Reset	Bit7	Bit6	Bit5	Bit4	Bit3	Bit2	Bit1	Bit0	
VNDRID_BY1	0	0x10	VNDRID[15:8]								
VNDRID_BY0	1	0x0B	VNDRID[7:0]								
PRODID	2	0x33	PRODID[7:0]								
REVID	3	0x00	REVID[7:0]								
SLAVEADR	8	0xB0	SLAVEADR[7:1]							RSRVD	
EEREV	9	0x00	EEREV[7:0]								
DEV_CTL	10	0x01	RSRVD	PLL_PDN	RSRVD				ENCAL	AUTOSTRT	
XO_CAPCTRL_BY1	16	0x00	RSRVD							XO_CAPCTRL[1:0]	
XO_CAPCTRL_BY0	17	0x00	XO_CAPCTRL[9:2]								
DIFFCTL	21	0x01	DIFF_OUT_PD	RSRVD					OUT_SEL[1:0]		
OUTDIV_BY1	22	0x00	RSRVD								
OUTDIV_BY0	23	0x20	OUT_DIV[7:0]								
PLL_NDIV_BY1	25	0x00	RSRVD					PLL_NDIV[11:8]			
PLL_NDIV_BY0	26	0x64	PLL_NDIV[7:0]								
PLL_FRACNUM_BY2	27	0x00	RSRVD			PLL_NUM[21:16]					
PLL_FRACNUM_BY1	28	0x00	PLL_NUM[15:8]								
PLL_FRACNUM_BY0	29	0x00	PLL_NUM[7:0]								
PLL_FRACDEN_BY2	30	0x00	RSRVD			PLL_DEN[21:16]					
PLL_FRACDEN_BY1	31	0x00	PLL_DEN[15:8]								
PLL_FRACDEN_BY0	32	0x00	PLL_DEN[7:0]								
PLL_MASHCTRL	33	0x0C	RSRVD				PLL_DTHRMODE[1:0]		PLL_ORDER[1:0]		
PLL_CTRL0	34	0x24	RSRVD			PLL_D	RSRVD		PLL_CP[3:0]		
PLL_CTRL1	35	0x03	RSRVD		PLL_CP_PHASE_SHIFT[2:0]		RSRVD		PLL_DISABLE_4TH[2:0]		
PLL_LF_R2	36	0x28	PLL_LF_R2[7:0]								
PLL_LF_C1	37	0x00	RSRVD							PLL_LF_C1[2:0]	
PLL_LF_R3	38	0x00	RSRVD		PLL_LF_R3[6:0]						
PLL_LF_C3	39	0x00	RSRVD							PLL_LF_C3[2:0]	
PLL_CALCTRL	40	0x00	RSRVD				PLL_CLSDWAIT[1:0]		PLL_VCOWAIT[1:0]		

**LMK61E2**

SNAS674 – SEPTEMBER 2015

[www.ti.com](http://www.ti.com)
**Register Map (continued)**

Name	Addr	Reset	Bit7	Bit6	Bit5	Bit4	Bit3	Bit2	Bit1	Bit0
NVMSCRC	47	0x00	NVMSCRC[7:0]							
NVMCNT	48	0x00	NVMCNT[7:0]							
NVMCTL	49	0x10	RSRVD	REGCOMMIT	NVMCRCERR	NVMAUTCRC	NVMCOMMIT	NVMBUSY	NVMERASE	NVMPROG
NVMLCRC	50	0x00	NVMLCRC[7:0]							
MEMADR	51	0x00	RSRVD	MEMADR[6:0]						
NVMDAT	52	0x00	NVMDAT[7:0]							
RAMDAT	53	0x00	RAMDAT[7:0]							
NVMUNLK	56	0x00	NVMUNLK[7:0]							
INT_LIVE	66	0x00	RSRVD						LOL	CAL
SWRST	72	0x00	RSRVD						SWR2PLL	RSRVD

## 8.6.1 Register Descriptions

### 8.6.1.1 VNDRID\_BY1 Register; R0

VNDRID\_BY1 and VNDRID\_BY0 registers are used to store the unique 16-bit Vendor Identification number assigned to I<sup>2</sup>C vendors.

Bit #	Field	Type	Reset	NVM	Description
[7:0]	VNDRID[15:8]	R	0x10	N	Vendor Identification Number Byte 1.

### 8.6.1.2 VNDRID\_BY0 Register; R1

VNDRID\_BY1 and VNDRID\_BY0 registers are used to store the unique 16-bit Vendor Identification number assigned to I<sup>2</sup>C vendors.

Bit #	Field	Type	Reset	NVM	Description
[7:0]	VNDRID[7:0]	R	0xB	N	Vendor Identification Number Byte 0.

### 8.6.1.3 PRODID Register; R2

The Product Identification Number is a unique 8-bit identification number used to identify the LMK61E2.

Bit #	Field	Type	Reset	NVM	Description
[7:0]	PRODID[7:0]	R	0x33	N	Product Identification Number.

### 8.6.1.4 REVID Register; R3

The REVID register is used to identify the LMK61E2 mask revision.

Bit #	Field	Type	Reset	NVM	Description
[7:0]	REVID[7:0]	R	0x0	N	Device Revision Number. The Device Revision Number is used to identify the LMK61E2 mask-set revision used to fabricate this device.

### 8.6.1.5 SLAVEADR Register; R8

The SLAVEADR register reflects the 7-bit I<sup>2</sup>C Slave Address value initialized from from on-chip EEPROM.

Bit #	Field	Type	Reset	NVM	Description								
[7:1]	SLAVEADR[7:1]	R	0x58	Y	I <sup>2</sup> C Slave Address. This field holds the 7-bit Slave Address used to identify this device during I <sup>2</sup> C transactions. The two least significant bits of the address can be configured using ADD as shown.								
					<table border="1"> <thead> <tr> <th>SLAVEADR[2:1]</th> <th>ADD</th> </tr> </thead> <tbody> <tr> <td>00</td> <td>0</td> </tr> <tr> <td>01</td> <td>Float</td> </tr> <tr> <td>10</td> <td>1</td> </tr> </tbody> </table>	SLAVEADR[2:1]	ADD	00	0	01	Float	10	1
SLAVEADR[2:1]	ADD												
00	0												
01	Float												
10	1												
[0]	RSRVD	-	-	N	Reserved.								

### 8.6.1.6 EEREV Register; R9

The EEREV register provides an EEPROM image revision record. EEPROM Image Revision is automatically retrieved from EEPROM and stored in the EEREV register after a reset or after a NVM commit operation.

Bit #	Field	Type	Reset	NVM	Description
[7:0]	EEREV[7:0]	R	0x0	Y	EEPROM Image Revision ID

### 8.6.1.7 DEV\_CTL Register; R10

The DEV\_CTL register holds the control functions described in the following table.

Bit #	Field	Type	Reset	NVM	Description						
[7]	RESERVED	-	0	Y	Reserved.						
[6]	PLL_PDN	RW	0	Y	<p>PLL Powerdown. The PLL_PDN bit determines whether PLL is automatically enabled and calibrated after a hardware reset. If the PLL_PDN bit is set to 1 during normal operation then PLL is disabled and the calibration circuit is reset. When PLL_PDN is then cleared to 0 PLL is re-enabled and the calibration sequence is automatically restarted.</p> <table border="1"> <thead> <tr> <th>PLL_PDN</th> <th>Value</th> </tr> </thead> <tbody> <tr> <td>0</td> <td>PLL Enabled</td> </tr> <tr> <td>1</td> <td>PLL Disabled</td> </tr> </tbody> </table>	PLL_PDN	Value	0	PLL Enabled	1	PLL Disabled
PLL_PDN	Value										
0	PLL Enabled										
1	PLL Disabled										
[5:2]	RESERVED[5:2]	RW	0	Y	Reserved.						
[1]	ENCAL	RWSC	0	N	Enable Frequency Calibration. Triggers PLL/VCO calibration on both PLLs in parallel on 0 -> 1 transition of ENCAL. This bit is self-clearing and set to a 0 after PLL/VCO calibration is complete. In powerup or software rest mode, AUTOSTRT takes precedence.						
[0]	AUTOSTRT	RW	1	Y	Autostart. If AUTOSTRT is set to 1 the device will automatically attempt to achieve lock and enable outputs after a device reset. A device reset can be triggered by the power-on-reset, RESETn pin or by writing to the RESETN_SW bit. If AUTOSTRT is 0 then the device will halt after the configuration phase, a subsequent write to set the AUTOSTRT bit to 1 will trigger the PLL Lock sequence.						

### 8.6.1.8 XO\_CAPCTRL\_BY1 Register; R16

XO Margining Offset Value bits[9:8]

Bit #	Field	Type	Reset	NVM	Description
[7:2]	RSRVD[5:0]	-	-	N	Reserved.
[1:0]	XO_CAPCTRL [1:0]	RW	0x0	Y	XO Offset Value bits [1:0]

### 8.6.1.9 XO\_CAPCTRL\_BY0 Register; R17

XO margining Offset Value bits[7:0]

Bit #	Field	Type	Reset	NVM	Description
[7:0]	XO_CAPCTRL [9:2]	RW	0x0	Y	XO Offset Value bits[9:2]

### 8.6.1.10 DIFFCTL Register; R21

The DIFFCTL register provides control over Output.

Bit #	Field	Type	Reset	NVM	Description										
[7]	DIFF_OUT_PD	RW	0	N	Power down differential output buffer.										
[6:2]	RESERVED	-	-	N	Reserved.										
[1:0]	OUT_SEL[1:0]	RW	0x1	Y	<p>Channel Output Driver Format Select. The OUT_SEL field controls the Channel Output Driver as shown below.</p> <table border="1"> <thead> <tr> <th>OUT_SEL</th> <th>OUTPUT OPERATION</th> </tr> </thead> <tbody> <tr> <td>0</td> <td>Tri-State</td> </tr> <tr> <td>1</td> <td>LVPECL</td> </tr> <tr> <td>2</td> <td>LVDS</td> </tr> <tr> <td>3</td> <td>HCSL</td> </tr> </tbody> </table>	OUT_SEL	OUTPUT OPERATION	0	Tri-State	1	LVPECL	2	LVDS	3	HCSL
OUT_SEL	OUTPUT OPERATION														
0	Tri-State														
1	LVPECL														
2	LVDS														
3	HCSL														

### 8.6.1.11 OUTDIV\_BY1 Register; R22

The 8-bit output integer divider value is set by the OUTDIV\_BY1 and OUTDIV\_BY0 registers.

Bit #	Field	Type	Reset	NVM	Description																				
[7:1]	RESERVED	RW	0x0	Y	Reserved.																				
[0]	OUT_DIV[8]	RW	0	Y	Channel's Output Divider Byte 1. Bit 8 The Channel Divider, OUT_DIV, is a 9-bit divider. The valid values for OUT_DIV range from 5 to 511 as shown below.																				
					<table border="1"> <thead> <tr> <th>OUT_DIV</th> <th>DIVIDE RATIO</th> </tr> </thead> <tbody> <tr> <td>0-4</td> <td>RESERVED</td> </tr> <tr> <td>5</td> <td>5</td> </tr> <tr> <td>6</td> <td>6</td> </tr> <tr> <td>7</td> <td>7</td> </tr> <tr> <td>255</td> <td>255</td> </tr> <tr> <td>256</td> <td>256</td> </tr> <tr> <td>257</td> <td>257</td> </tr> <tr> <td>...</td> <td>...</td> </tr> <tr> <td>511</td> <td>511</td> </tr> </tbody> </table>	OUT_DIV	DIVIDE RATIO	0-4	RESERVED	5	5	6	6	7	7	255	255	256	256	257	257	...	...	511	511
OUT_DIV	DIVIDE RATIO																								
0-4	RESERVED																								
5	5																								
6	6																								
7	7																								
255	255																								
256	256																								
257	257																								
...	...																								
511	511																								

### 8.6.1.12 OUTDIV\_BY0 Register; R23

The 8-bit output integer divider value is set by the OUTDIV\_BY1 and OUTDIV\_BY0 registers.

Bit #	Field	Type	Reset	NVM	Description																		
[7:0]	OUT_DIV[7:0]	RW	0x20	Y	Channel's Output Divider Byte 0. Bit 8 The Channel Divider, OUT_DIV, is a 9-bit divider. The valid values for OUT_DIV range from 5 to 511 as shown below																		
					<table border="1"> <thead> <tr> <th>OUT_DIV</th> <th>DIVIDE RATIO</th> </tr> </thead> <tbody> <tr> <td>0-4</td> <td>RESERVED</td> </tr> <tr> <td>5</td> <td>5</td> </tr> <tr> <td>6</td> <td>6</td> </tr> <tr> <td>7</td> <td>7</td> </tr> <tr> <td>255</td> <td>255</td> </tr> <tr> <td>256</td> <td>256</td> </tr> <tr> <td>...</td> <td>...</td> </tr> <tr> <td>511</td> <td>511</td> </tr> </tbody> </table>	OUT_DIV	DIVIDE RATIO	0-4	RESERVED	5	5	6	6	7	7	255	255	256	256	...	...	511	511
OUT_DIV	DIVIDE RATIO																						
0-4	RESERVED																						
5	5																						
6	6																						
7	7																						
255	255																						
256	256																						
...	...																						
511	511																						

### 8.6.1.13 PLL\_NDIV\_BY1 Register; R25

The 12-bit N integer divider value for PLL is set by the PLL\_NDIV\_BY1 and PLL\_NDIV\_BY0 registers.

Bit #	Field	Type	Reset	NVM	Description
[7:4]	RSRVD	-	-	N	Reserved.
[3:0]	PLL_NDIV[11:8]	RW	0x0	Y	PLL N Divider Byte 1. PLL Integer N Divider bits [11:8].

### 8.6.1.14 PLL\_NDIV\_BY0 Register; R26

The PLL\_NDIV\_BY0 register is described in the following table.

Bit #	Field	Type	Reset	NVM	Description
[7:0]	PLL_NDIV[7:0]	RW	0x64	Y	PLL N Divider Byte 0. PLL Integer N Divider bits [7:0].

### 8.6.1.15 PLL\_FRACNUM\_BY2 Register; R27

The 21-bit Fractional Divider Numerator value for PLL is set by registers PLL\_FRACNUM\_BY2, PLL\_FRACNUM\_BY1 and PLL\_FRACNUM\_BY0.

Bit #	Field	Type	Reset	NVM	Description
[7:6]	RSRVD	-	-	N	Reserved.
[5:0]	PLL_NUM[21:16]	RW	0x0	Y	PLL Fractional Divider Numerator Byte 2. Bits [21:16]

### 8.6.1.16 PLL\_FRACNUM\_BY1 Register; R28

The PLL\_FRACNUM\_BY1 register is described in the following table.

Bit #	Field	Type	Reset	NVM	Description
[7:0]	PLL_NUM[15:8]	RW	0x0	Y	PLL Fractional Divider Numerator Byte 1. Bits [15:8].

### 8.6.1.17 PLL\_FRACNUM\_BY0 Register; R29

The PLL\_FRACNUM\_BY0 register is described in the following table.

Bit #	Field	Type	Reset	NVM	Description
[7:0]	PLL_NUM[7:0]	RW	0x0	Y	PLL Fractional Divider Numerator Byte 0. Bits [7:0].

### 8.6.1.18 PLL\_FRACDEN\_BY2 Register; R30

The 21-bit Fractional Divider Denominator value for PLL is set by registers PLL\_FRACDEN\_BY2, PLL\_FRACDEN\_BY1 and PLL\_FRACDEN\_BY0.

Bit #	Field	Type	Reset	NVM	Description
[7:6]	RSRVD	-	-	N	Reserved.
[5:0]	PLL_DEN[21:16]	RW	0x0	Y	PLL Fractional Divider Denominator Byte 2. Bits [21:16].

### 8.6.1.19 PLL\_FRACDEN\_BY1 Register; R31

The PLL\_FRACDEN\_BY1 register is described in the following table.

Bit #	Field	Type	Reset	NVM	Description
[7:0]	PLL_DEN[15:8]	RW	0x0	Y	PLL Fractional Divider Denominator Byte 1. Bits [15:8].

### 8.6.1.20 PLL\_FRACDEN\_BY0 Register; R32

The PLL\_FRACDEN\_BY0 register is described in the following table.

Bit #	Field	Type	Reset	NVM	Description
[7:0]	PLL_DEN[7:0]	RW	0x0	Y	PLL Fractional Divider Denominator Byte 0. Bits [7:0].

### 8.6.1.21 PLL\_MASHCTRL Register; R33

The PLL\_MASHCTRL register provides control of the fractional divider for PLL.

Bit #	Field	Type	Reset	NVM	Description										
[7:4]	RSRVD	-	-	N	Reserved.										
[3:2]	PLL_DTHRMODE[1:0]	RW	0x3	Y	Mash Engine dither mode control.										
					<table border="1"> <thead> <tr> <th>DITHERMODE</th> <th>Dither Configuration</th> </tr> </thead> <tbody> <tr> <td>00</td> <td>Weak</td> </tr> <tr> <td>01</td> <td>Reserved</td> </tr> <tr> <td>10</td> <td>Reserved</td> </tr> <tr> <td>11</td> <td>Dither Disabled</td> </tr> </tbody> </table>	DITHERMODE	Dither Configuration	00	Weak	01	Reserved	10	Reserved	11	Dither Disabled
DITHERMODE	Dither Configuration														
00	Weak														
01	Reserved														
10	Reserved														
11	Dither Disabled														

Bit #	Field	Type	Reset	NVM	Description	
[1:0]	PLL_ORDER[1:0]	RW	0x0	Y	Mash Engine Order.	
					<b>ORDER</b>	<b>Order Configuration</b>
					00	Integer Mode Divider
					01	Reserved
					10	Reserved
11	3rd order					

### 8.6.1.22 PLL\_CTRL0 Register; R34

The PLL\_CTRL1 register provides control of PLL. The PLL\_CTRL1 register fields are described in the following table.

Bit #	Field	Type	Reset	NVM	Description	
[7:6]	RESERVED	RW	0x0	Y	Reserved.	
[5]	PLL_D	RW	1	Y	PLL R Divider Frequency Doubler Enable. If PLL_D is 1 the R Divider Frequency Doubler is enabled.	
[4]	RSRVD	-	-	N	Reserved.	
[3:0]	PLL_CP[3:0]	RW	0x4	Y	PLL Charge Pump Gain.	
					<b>PLL_CP[3:0]</b>	<b>PLL Charge Pump Gain</b>
					1000	6.4 mA
					0100	1.6 mA

### 8.6.1.23 PLL\_CTRL1 Register; R35

The PLL\_CTRL3 register provides control of PLL. The PLL\_CTRL3 register fields are described in the following table.

Bit #	Field	Type	Reset	NVM	Description	
[7]	RSRVD	-	-	N	Reserved.	
[6:4]	PLL_CP_PHASE_SHIFT[2:0]	RW	0x0	Y	Program Charge Pump Phase Shift.	
					<b>PLL_CP_PHASE_SHIFT[2:0]</b>	<b>Ohms Delay Shift</b>
					000	1.5-M No delay
					001	6.8-k 1.3 ns for 100 MHz PFD
					010	8.5-k 1 ns for 100 MHz PFD
					011	10-k 0.9 ns for 100 MHz PFD
					100	14-k 1.3 ns for 50 MHz PFD
					101	17-k 1 ns for 50 MHz PFD
					110	20-k 0.9 ns for 50 MHz PFD
111	24-k 0.7 ns for 50 MHz PFD					
[3]	RSRVD	-	-	N	Reserved.	
[2]	PLL_DISABLE_4TH	RW	0x0	Y	Disable Capacitor in the low pass filter.	
					<b>PLL_DISABLE_4TH</b>	<b>MODE</b>
					0	2nd order loop filter recommended setting
1	Enables C3, 3rd order loop filter enabled					
[1:0]	RESERVED.	-	0x2	Y	Reserved.	

### 8.6.1.24 PLL\_LF\_R2 Register; R36

The PLL\_LF\_R2 register controls the value of the PLL Loop Filter R2.

Bit #	Field	Type	Reset	NVM	Description														
[7:0]	PLL_LF_R2[7:0]	RW	0x28	Y	PLL Loop Filter R2. Binary weighted resistor ladder. The resistance for each bit is shown in the table below.														
					<table border="1"> <thead> <tr> <th>PLL_LF_R2[7:0]</th> <th>R2 (ohms)</th> </tr> </thead> <tbody> <tr> <td>000000</td> <td>150</td> </tr> <tr> <td>000001</td> <td>400</td> </tr> <tr> <td>000010</td> <td>800</td> </tr> <tr> <td>000100</td> <td>1600</td> </tr> <tr> <td>001000</td> <td>3200</td> </tr> <tr> <td>010000</td> <td>6400</td> </tr> </tbody> </table>	PLL_LF_R2[7:0]	R2 (ohms)	000000	150	000001	400	000010	800	000100	1600	001000	3200	010000	6400
PLL_LF_R2[7:0]	R2 (ohms)																		
000000	150																		
000001	400																		
000010	800																		
000100	1600																		
001000	3200																		
010000	6400																		

### 8.6.1.25 PLL\_LF\_C1 Register; R37

The PLL\_LF\_C1 register controls the value of the PLL Loop Filter C1.

Bit #	Field	Type	Reset	NVM	Description
[7:3]	RSRVD	-	-	N	Reserved.
[2:0]	PLL_LF_C1[2:0]	RW	0x0	Y	PLL Loop Filter C1. The value in pF is given by $5 + 50 * \text{PLL\_LF\_C1}$ (in decimal).

### 8.6.1.26 PLL\_LF\_R3 Register; R38

The PLL\_LF\_R3 register controls the value of the PLL Loop Filter R3.

Bit #	Field	Type	Reset	NVM	Description																		
[7]	RSRVD	-	-	N	Reserved.																		
[6:0]	PLL_LF_R3[6:0]	RW	0x0	Y	PLL Loop Filter R3. Binary weighted resistor ladder. The resistance for each bit is shown in the table below.																		
					<table border="1"> <thead> <tr> <th>PLL_LF_R3[6:0]</th> <th>R3 (ohms)</th> </tr> </thead> <tbody> <tr> <td>0000000</td> <td>100</td> </tr> <tr> <td>0000001</td> <td>200</td> </tr> <tr> <td>0000010</td> <td>300</td> </tr> <tr> <td>0000100</td> <td>500</td> </tr> <tr> <td>0001000</td> <td>700</td> </tr> <tr> <td>0010000</td> <td>800</td> </tr> <tr> <td>0100000</td> <td>1600</td> </tr> <tr> <td>1000000</td> <td>3200</td> </tr> </tbody> </table>	PLL_LF_R3[6:0]	R3 (ohms)	0000000	100	0000001	200	0000010	300	0000100	500	0001000	700	0010000	800	0100000	1600	1000000	3200
PLL_LF_R3[6:0]	R3 (ohms)																						
0000000	100																						
0000001	200																						
0000010	300																						
0000100	500																						
0001000	700																						
0010000	800																						
0100000	1600																						
1000000	3200																						

### 8.6.1.27 PLL\_LF\_C3 Register; R39

The PLL\_LF\_C3 register controls the value of the PLL Loop Filter C3.

Bit #	Field	Type	Reset	NVM	Description
[7:3]	RSRVD	-	-	N	Reserved.
[2:0]	PLL_LF_C3[2:0]	RW	0x0	Y	PLL Loop Filter C3. The value in pF is given by $5 * \text{PLL\_LF\_C3}$ (in decimal).

### 8.6.1.28 PLL\_CALCTRL Register; R42

The PLL\_CALCTRL register is described in the following table.

Bit #	Field	Type	Reset	NVM	Description										
[7:4]	RSRVD	-	-	N	Reserved.										
[3:2]	PLL_CLSDWAIT[1:0]	RW	0x0	Y	Closed Loop Wait Period. The CLSDWAIT field sets the closed loop wait period, in periods of the always on clock as follows. <table border="1" data-bbox="878 447 1469 642"> <thead> <tr> <th>CLSDWAIT</th> <th>Anlog closed loop VCO stabilization time</th> </tr> </thead> <tbody> <tr> <td>0</td> <td>150us</td> </tr> <tr> <td>1</td> <td>300us</td> </tr> <tr> <td>2</td> <td>500us</td> </tr> <tr> <td>3</td> <td>2000us</td> </tr> </tbody> </table>	CLSDWAIT	Anlog closed loop VCO stabilization time	0	150us	1	300us	2	500us	3	2000us
CLSDWAIT	Anlog closed loop VCO stabilization time														
0	150us														
1	300us														
2	500us														
3	2000us														
[1:0]	PLL_VCOWAIT[1:0]	RW	0x0	Y	VCO Wait Period. <table border="1" data-bbox="878 684 1469 848"> <thead> <tr> <th>VCOWAIT</th> <th>VCO stabilization time</th> </tr> </thead> <tbody> <tr> <td>0</td> <td>20us</td> </tr> <tr> <td>1</td> <td>400us</td> </tr> <tr> <td>2</td> <td>4000us</td> </tr> <tr> <td>3</td> <td>10000us</td> </tr> </tbody> </table>	VCOWAIT	VCO stabilization time	0	20us	1	400us	2	4000us	3	10000us
VCOWAIT	VCO stabilization time														
0	20us														
1	400us														
2	4000us														
3	10000us														

### 8.6.1.29 NVMSCRC Register; R47

The NVMSCRC register holds the Stored CRC byte that has been retrieved from on-chip EEPROM.

Bit #	Field	Type	Reset	NVM	Description
[7:0]	NVMSCRC[7:0]	R	0x0	Y	NVM Stored CRC.

### 8.6.1.30 NVMCNT Register; R48

The NVMCNT register is intended to reflect the number of on-chip EEPROM Erase/Program cycles that have taken place in EEPROM. The count is automatically incremented by hardware and stored in EEPROM.

Bit #	Field	Type	Reset	NVM	Description
[7:0]	NVMCNT[7:0]	R	0x0	Y	NVM Program Count. The NVMCNT increments automatically after every EEPROM Erase/Program Cycle. The NVMCNT value is retrieved automatically after reset, after a NVM Commit operation or after a Erase/Program cycle. The NVMCNT register will increment until it reaches its maximum value of 255 after which no further increments will take place.

### 8.6.1.31 NVMCTL Register; R49

The NVMCTL register allows control of the on-chip EEPROM Memories.

Bit #	Field	Type	Reset	NVM	Description
[7]	RSRVD	-	-	N	Reserved.
[6]	REGCOMMIT	RWSC	0	N	REG Commit to NVM SRAM Array. The REGCOMMIT bit is used to initiate a transfer from the on-chip registers back to the corresponding location in the NVM SRAM Array. The REGCOMMIT bit is automatically cleared to 0 when the transfer is complete.
[5]	NVMCRERR	R	0	N	NVM CRC Error Indication. The NVMCRERR bit is set to 1 if a CRC Error has been detected when reading back from on-chip EEPROM during device configuration.
[4]	NVMAUTOCRC	RW	1	N	NVM Automatic CRC. When NVMAUTOCRC is 1 then the EEPROM Stored CRC byte is automatically calculated whenever a EEPROM program takes place.

Bit #	Field	Type	Reset	NVM	Description
[3]	NVMCOMMIT	RWSC	0	N	NVM Commit to Registers. The NVMCOMMIT bit is used to initiate a transfer of the on-chip EEPROM contents to internal registers. The transfer happens automatically after reset or when NVMCOMMIT is set to 1. The NVMCOMMIT bit is automatically cleared to 0. The I <sup>2</sup> C registers cannot be read while a NVM Commit operation is taking place.
[2]	NVMBUSY	R	0	N	NVM Program Busy Indication. The NVMBUSY bit is 1 during an on-chip EEPROM Erase/Program cycle. While NVMBUSY is 1 the on-chip EEPROM cannot be accessed.
[1]	NVMERASE	RWSC	0	N	NVM Erase Start. The NVMERASE bit is used to begin an on-chip EEPROM Erase cycle. The Erase cycle is only initiated if the immediately preceding I <sup>2</sup> C transaction was a write to the NVMUNLK register with the appropriate code. The NVMERASE bit is automatically cleared to 0. The NVM Erase operation takes around 115ms.
[0]	NVMPROG	RWSC	0	N	NVM Program Start. The NVMPROG bit is used to begin an on-chip EEPROM Program cycle. The Program cycle is only initiated if the immediately preceding I <sup>2</sup> C transaction was a write to the NVMUNLK register with the appropriate code. The NVMPROG bit is automatically cleared to 0. If the NVMERASE and NVMPROG bits are set simultaneously then an ERASE/PROGRAM cycle will be executed. The NVM Program operation takes around 115ms.

### 8.6.1.32 MEMADR Register; R51

The MEMADR register holds 7-bits of the starting address for on-chip SRAM or EEPROM access.

Bit #	Field	Type	Reset	NVM	Description
[7]	RSRVD	-	-	N	Reserved.
[6:0]	MEMADR[6:0]	RW	0x0	N	Memory Address. The MEMADR value determines the starting address for on-chip SRAM read/write access or on-chip EEPROM access. The internal address to access SRAM or EEPROM is automatically incremented; however the MEMADR register does not reflect the internal address in this way. When the SRAM or EEPROM arrays are accessed using the I <sup>2</sup> C interface only bits [4:0] of MEMADR are used to form the byte Wise address.

### 8.6.1.33 NVMDAT Register; R52

The NVMDAT register returns the on-chip EEPROM contents from the starting address specified by the MEMADR register.

Bit #	Field	Type	Reset	NVM	Description
[7:0]	NVMDAT[7:0]	R	0x0	N	EEPROM Read Data. The first time an I <sup>2</sup> C read transaction accesses the NVMDAT register address, either because it was explicitly targeted or because the address was auto-incremented, the read transaction will return the EEPROM data located at the address specified by the MEMADR register. Any additional read's which are part of the same transaction will cause the EEPROM address to be incremented and the next EEPROM data byte will be returned. The I <sup>2</sup> C address will no longer be auto-incremented, i.e the I <sup>2</sup> C address will be locked to the NVMDAT register after the first access. Access to the NVMDAT register will terminate at the end of the current I <sup>2</sup> C transaction.

### 8.6.1.34 RAMDAT Register; R53

The RAMDAT register provides read and write access to the SRAM that forms part of the on-chip EEPROM module.

Bit #	Field	Type	Reset	NVM	Description
[7:0]	RAMDAT[7:0]	RW	0x0	N	RAM Read/Write Data. The first time an I <sup>2</sup> C read or write transaction accesses the RAMDAT register address, either because it was explicitly targeted or because the address was auto-incremented, a read transaction will return the RAM data located at the address specified by the MEMADR register and a write transaction will cause the current I <sup>2</sup> C data to be written to the address specified by the MEMADR register. Any additional accesses which are part of the same transaction will cause the RAM address to be incremented and a read or write access will take place to the next SRAM address. The I <sup>2</sup> C address will no longer be auto-incremented, i.e the I <sup>2</sup> C address will be locked to the RAMDAT register after the first access. Access to the RAMDAT register will terminate at the end of the current I <sup>2</sup> C transaction.

### 8.6.1.35 NVMUNLK Register; R56

The NVMUNLK register provides a rudimentary level of protection to prevent inadvertent programming of the on-chip EEPROM.

Bit #	Field	Type	Reset	NVM	Description
[7:0]	NVMUNLK[7:0]	RW	0x0	N	NVM Prog Unlock. The NVMUNLK register must be written immediately prior to setting the NVMPROG bit of register NVMCTL, otherwise the Erase/Program cycle will not be triggered. NVMUNLK must be written with a value of 0xBE.

### 8.6.1.36 INT\_LIVE Register; R66

The INT\_LIVE register reflects the current status of the interrupt sources.

Bit #	Field	Type	Reset	NVM	Description
[7:2]	RESERVED.	R	0	N	Reserved.
[1]	LOL	R	0	N	Loss of Lock PLL.
[0]	CAL	R	0	N	Calibration Active PLL.

### 8.6.1.37 SWRST Register; R72

The SWRST1 register provides software reset control for specific on-chip modules. Each bit in this register is individually self cleared after a write operation. The SWRST1 register will always return 0x00 in a read transaction.

Bit #	Field	Type	Reset	NVM	Description
[7:2]	RESERVED.	RW	0x0	N	Reserved.
[1]	SWR2PLL	RWSC	0	N	Software Reset PLL. Setting SWR2PLL to 1 resets the PLL calibrator and clock dividers. This bit is automatically cleared to 0.
[0]	RESERVED.	-	0	N	Reserved.

**LMK61E2**

SNAS674 – SEPTEMBER 2015

[www.ti.com](http://www.ti.com)
**8.7 EEPROM Map**

Any bit that is labeled as "RSRVD" should be written with a "0".

Byte #	Bit7	Bit6	Bit5	Bit4	Bit3	Bit2	Bit1	Bit0
4	NVMSCRC[7]	NVMSCRC[6]	NVMSCRC[5]	NVMSCRC[4]	NVMSCRC[3]	NVMSCRC[2]	NVMSCRC[1]	NVMSCRC[0]
5	NVMCNT[7]	NVMCNT[6]	NVMCNT[5]	NVMCNT[4]	NVMCNT[3]	NVMCNT[2]	NVMCNT[1]	NVMCNT[0]
9	SLAVEADR[7]	SLAVEADR[6]	SLAVEADR[5]	SLAVEADR[4]	SLAVEADR[3]	RSRVD	RSRVD	RSRVD
10	EEREV[7]	EEREV[6]	EEREV[5]	EEREV[4]	EEREV[3]	EEREV[2]	EEREV[1]	EEREV[0]
11	RSRVD	PLL_PDN	RSRVD	RSRVD	RSRVD	RSRVD	AUTOSTRT	RSRVD
14	XO_PWRCTRL[0]	DELAY_CTRL[3]	DELAY_CTRL[2]	DELAY_CTRL[1]	DELAY_CTRL[0]	XO_TIMER[2]	XO_TIMER[1]	XO_TIMER[0]
15	RSRVD	XO_CAPCTRL[1]	XO_CAPCTRL[0]	XO_CAPCTRL[9]	XO_CAPCTRL[8]	XO_CAPCTRL[7]	XO_CAPCTRL[6]	XO_CAPCTRL[5]
16	XO_CAPCTRL[4]	XO_CAPCTRL[3]	XO_CAPCTRL[2]	RSRVD	RSRVD	RSRVD	RSRVD	RSRVD
19	RSRVD	RSRVD	RSRVD	RSRVD	RSRVD	RSRVD	RSRVD	OUT_SEL[2]
20	OUT_SEL[1]	OUT_SEL[0]	RSRVD	RSRVD	RSRVD	RSRVD	RSRVD	RSRVD
21	RSRVD	RSRVD	RSRVD	RSRVD	RSRVD	RSRVD	RSRVD	RSRVD
22	PLL_NDIV[11]	PLL_NDIV[10]	PLL_NDIV[9]	PLL_NDIV[8]	PLL_NDIV[7]	PLL_NDIV[6]	PLL_NDIV[5]	PLL_NDIV[4]
23	PLL_NDIV[3]	PLL_NDIV[2]	PLL_NDIV[1]	PLL_NDIV[0]	PLL_NUM[21]	PLL_NUM[20]	PLL_NUM[19]	PLL_NUM[18]
24	PLL_NUM[17]	PLL_NUM[16]	PLL_NUM[15]	PLL_NUM[14]	PLL_NUM[13]	PLL_NUM[12]	PLL_NUM[11]	PLL_NUM[10]
25	PLL_NUM[9]	PLL_NUM[8]	PLL_NUM[7]	PLL_NUM[6]	PLL_NUM[5]	PLL_NUM[4]	PLL_NUM[3]	PLL_NUM[2]
26	PLL_NUM[1]	PLL_NUM[0]	PLL_DEN[21]	PLL_DEN[20]	PLL_DEN[19]	PLL_DEN[18]	PLL_DEN[17]	PLL_DEN[16]
27	PLL_DEN[15]	PLL_DEN[14]	PLL_DEN[13]	PLL_DEN[12]	PLL_DEN[11]	PLL_DEN[10]	PLL_DEN[9]	PLL_DEN[8]
28	PLL_DEN[7]	PLL_DEN[6]	PLL_DEN[5]	PLL_DEN[4]	PLL_DEN[3]	PLL_DEN[2]	PLL_DEN[1]	PLL_DEN[0]
29	PLL_DTHRMODE[1]	PLL_DTHRMODE[0]	PLL_ORDER[1]	PLL_ORDER[0]	PLL_STRETCH	RSRVD	PLL_D	PLL_CP[3]
30	PLL_CP[2]	PLL_CP[1]	PLL_CP[0]	PLL_CP_PHASE_SHIFT[2]	PLL_CP_PHASE_SHIFT[1]	PLL_CP_PHASE_SHIFT[0]	PLL_DISABLE_4TH[2]	PLL_DISABLE_4TH[1]
31	PLL_DISABLE_4TH[0]	PLL_LF_R2[7]	PLL_LF_R2[6]	PLL_LF_R2[5]	PLL_LF_R2[4]	PLL_LF_R2[3]	PLL_LF_R2[2]	PLL_LF_R2[1]
32	PLL_LF_R2[0]	PLL_LF_C1[2]	PLL_LF_C1[1]	PLL_LF_C1[0]	PLL_LF_R3[6]	PLL_LF_R3[5]	PLL_LF_R3[4]	PLL_LF_R3[3]
33	PLL_LF_R3[2]	PLL_LF_R3[1]	PLL_LF_R3[0]	PLL_LF_C3[2]	PLL_LF_C3[1]	PLL_LF_C3[0]	RSRVD	RSRVD
34	RSRVD	OUT_DIV[8]	OUT_DIV[7]	OUT_DIV[6]	OUT_DIV[5]	OUT_DIV[4]	OUT_DIV[3]	OUT_DIV[2]
35	OUT_DIV[1]	OUT_DIV[0]	RSRVD	RSRVD	RSRVD	RSRVD	RSRVD	RSRVD

## 9 Application and Implementation

### NOTE

Information in the following applications sections is not part of the TI component specification, and TI does not warrant its accuracy or completeness. TI's customers are responsible for determining suitability of components for their purposes. Customers should validate and test their design implementation to confirm system functionality.

### 9.1 Application Information

The LMK61E2 is an ultra-low jitter programmable oscillator that can be used to provide reference clocks for high-speed serial links resulting in improved system performance. The LMK61E2 also supports a variety of features that aids the hardware designer during the system debug and validation phase.

### 9.2 Typical Applications

#### 9.2.1 Jitter Considerations in Serdes Systems

Jitter-sensitive applications such as 10 Gbps or 100 Gbps Ethernet, deploy a serial link utilizing a Serializer in the transmit section (TX) and a De-serializer in the receive section (RX). These SERDES blocks are typically embedded in an ASIC or FPGA. Estimating the clock jitter impact on the link budget requires understanding of the TX PLL bandwidth and the RX CDR bandwidth.

As can be seen in [Figure 32](#), the pass band region between the TX low pass cutoff and RX high pass cutoff frequencies is the range over which the reference clock jitter adds without any attenuation to the jitter budget of the link. Outside of these frequencies, the SERDES link will attenuate the reference clock jitter with a 20 dB/dec or even steeper roll-off. Modern ASIC or FPGA designs have some flexibility on deciding the optimal RX CDR bandwidth and TX PLL bandwidth. These bandwidths are typically set based on what is achievable in the ASIC or FPGA process node, without increasing design complexity, and on any jitter tolerance or wander specification that needs to be met, as related to the RX CDR bandwidth.

The overall allowable jitter in a serial link is dictated by IEEE or other relevant standards. For example, IEEE802.3ba states that the maximum transmit jitter (peak-peak) for 10 Gbps Ethernet should be no more than  $0.28 * UI$  and this equates to a 27.1516 ps, p-p for the overall allowable transmit jitter.

The jitter contributing elements are made up of the reference clock, generated potentially from a device like LMK61E2, the transmit medium, transmit driver etc. Only a portion of the overall allowable transmit jitter is allocated to the reference clock, typically 20% or lower. Therefore, the allowable reference clock jitter, for a 20% clock jitter budget, is 5.43 ps, p-p.

Jitter in a reference clock is made up of deterministic jitter (arising from spurious signals due to supply noise or mixing from other outputs or from the reference input) and random jitter (usually due to thermal noise and other uncorrelated noise sources). A typical clock tree in a serial link system consists of clock generators and fanout buffers. The allowable reference clock jitter of 5.43 ps, p-p is needed at the output of the fanout buffer. Modern fanout buffers have low additive random jitter (less than 100 fs, rms) with no substantial contribution to the deterministic jitter. Therefore, the clock generator and fanout buffer contribute to the random jitter while the primary contributor to the deterministic jitter is the clock generator. Rule of thumb, for modern clock generators, is to allocate 25% of allowable reference clock jitter to the deterministic jitter and 75% to the random jitter. This amounts to an allowable deterministic jitter of 1.36 ps, p-p and an allowable random jitter of 4.07 ps, p-p. For serial link systems that need to meet a bit error rate (BER) of  $10^{-12}$ , the allowable random jitter in root-mean-square is 0.29 ps, rms. This is calculated by dividing the p-p jitter by 14 for a BER of  $10^{-12}$ . Accounting for random jitter from the fanout buffer, the random jitter needed from the clock generator is 0.27 ps, rms. This is calculated by the root-mean-square subtraction from the desired jitter at the fanout buffer's output assuming 100 fs, rms of additive jitter from the fanout buffer.

With careful frequency planning techniques, like spur optimization (covered in the Spur Mitigation Techniques section) and on-chip LDOs to suppress supply noise, the LMK61E2 is able to generate clock outputs with deterministic jitter that is below 1 ps, p-p and random jitter that is below 0.2 ps, rms. This gives the serial link system with additional margin on the allowable transmit jitter resulting in a BER better than  $10^{-12}$ .

Typical Applications (continued)

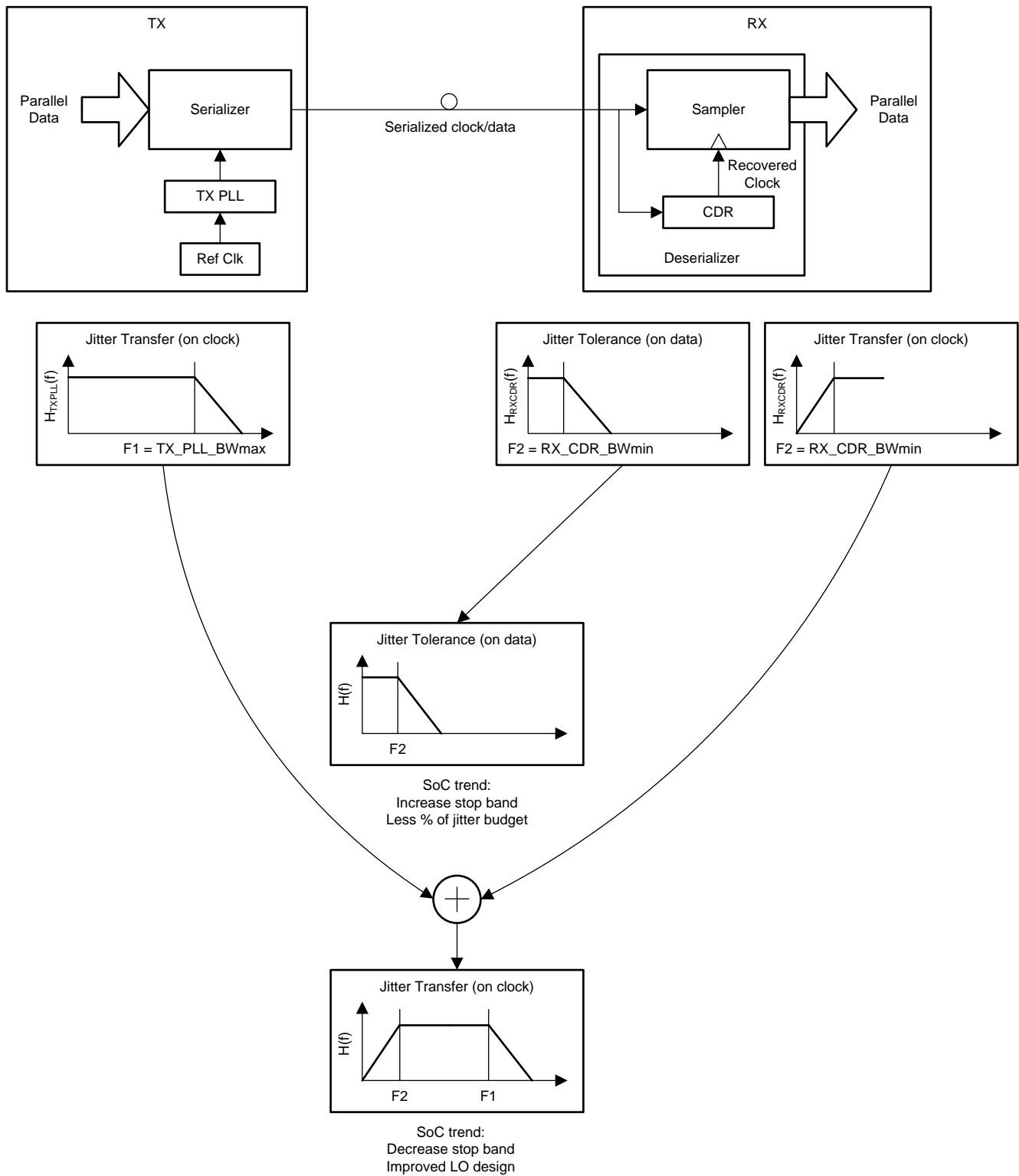

Figure 32. Dependence of Clock Jitter in Serial Links

## Typical Applications (continued)

### 9.2.2 Frequency Margining

#### 9.2.2.1 Fine Frequency Margining

IEEE802.3 dictates that Ethernet frames stay compliant to the standard specifications when clocked with a reference clock that is within  $\pm 100$  ppm of its nominal frequency. In the worst case, an RX node with its local reference clock at  $-100$  ppm from its nominal frequency should be able to work seamlessly with a TX node that has its own local reference clock at  $+100$  ppm from its nominal frequency. Without any clock compensation on the RX node, the read pointer will severely lag behind the write pointer and cause FIFO overflow errors. On the contrary, when the RX node's local clock operates at  $+100$  ppm from its nominal frequency and the TX node's local clock operates at  $-100$  ppm from its nominal frequency, FIFO underflow errors occur without any clock compensation.

In order to prevent such overflow and underflow errors from occurring, modern ASICs and FPGAs include a clock compensation scheme that introduces elastic buffers. Such a system, shown in Figure 33, is validated thoroughly during the validation phase by interfacing slower nodes with faster ones and ensuring compliance to IEEE802.3. The LMK61E2 provides the ability to fine tune the frequency of its outputs based on changing its load capacitance for the integrated oscillator. This fine tuning can be done via I<sup>2</sup>C as described in Integrated Oscillator. The change in load capacitance is implemented in a manner such that the output of LMK61E2 undergoes a smooth monotonic change in frequency.

#### 9.2.2.2 Coarse Frequency Margining

Certain systems require the processors to be tested at clock frequencies that are slower or faster by 5% or 10%. The LMK61E2 offers the ability to change its output divider for the desired change from its nominal output frequency as explained in the "High-Speed Output Divider" sub-section.

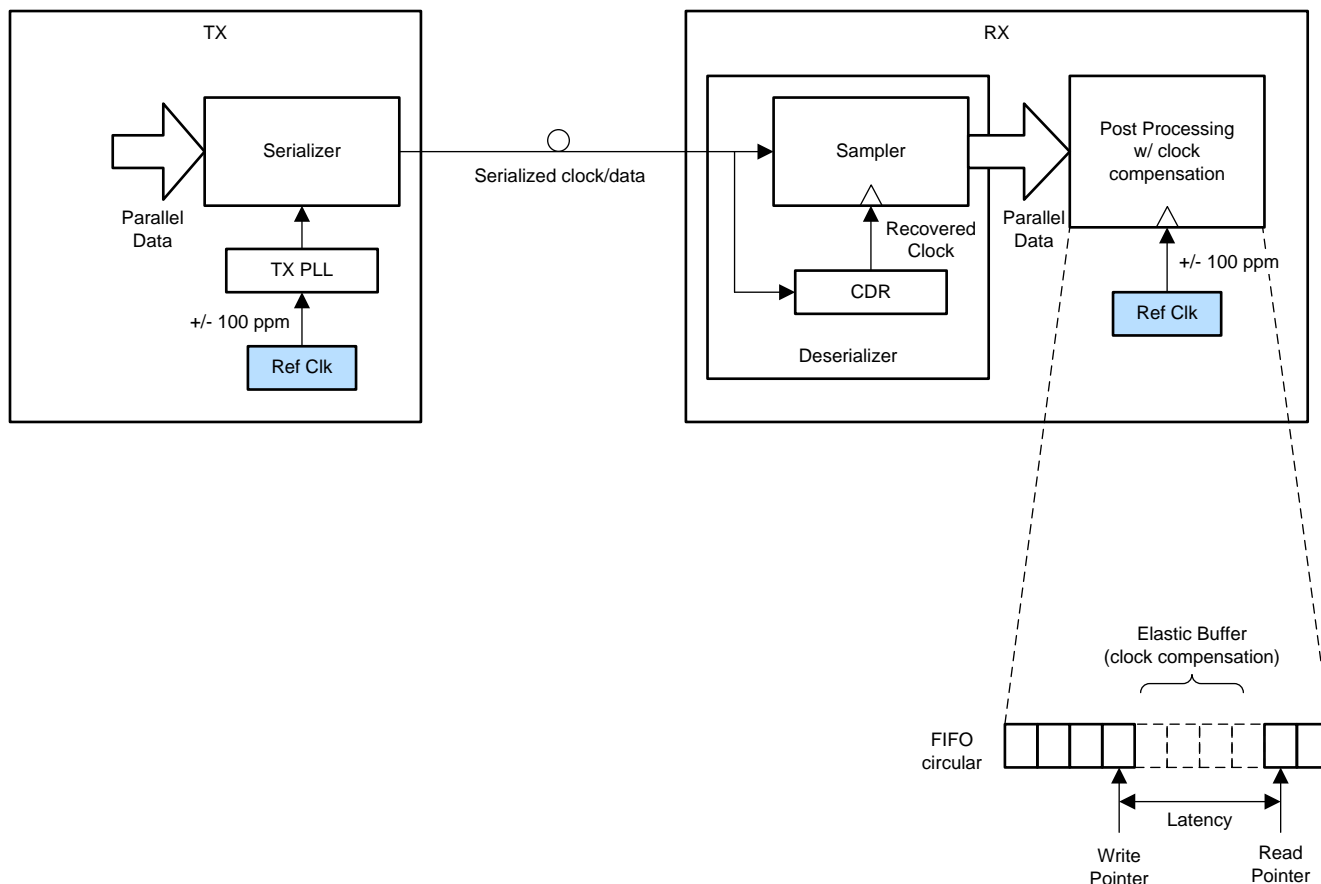

Figure 33. System Implementation with Clock Compensation for Standards Compliance

## Typical Applications (continued)

### 9.2.3 Design Requirements

Consider a typical wired communications application, like a top-of-rack switch, which needs to clock high data rate 10 Gbps or 100 Gbps Ethernet PHYs. In such systems, the clock is expected to be available upon powerup without the need for any device-level programming. An example of such a clock frequency would be a 156.25 MHz in LVPECL output format.

The section below describes the detailed design procedure to generate the required output frequencies for the above scenario using LMK61E2.

#### 9.2.3.1 Detailed Design Procedure

Design of all aspects of the LMK61E2 is simplified with software support that assists in part selection, part programming, loop filter design, and phase noise simulation. This design procedure will give a quick outline of the process.

##### 1. Device Selection

- The first step to calculate the specified VCO frequency given required output frequency. The device must be able to produce the VCO frequency that can be divided down to the required output frequency.
- The WEBENCH Clock Architect Tool from TI will aid in the selection of the right device that meets the customer's output frequency and format requirements.

##### 2. Device Configuration

- There are many device configurations to achieve the desired output frequency from a device. However there are some optimizations and trade-offs to be considered.
- The WEBENCH Clock Architect Tool attempts to maximize the phase detector frequency, use smallest dividers, and maximizes PLL charge pump current.
- These guidelines below may be followed when configuring PLL related dividers or other related registers:
  - For lowest possible in-band PLL flat noise, maximize phase detector frequency to minimize N divide value.
  - For lowest possible in-band PLL flat noise, maximize charge pump current. The highest value charge pump currents often have similar performance due to diminishing returns.
  - For fractional divider values, keep the denominator at highest value possible in order to minimize spurs. It is also best to use higher order modulator wherever possible for the same reason.
  - As a rule of thumb, keeping the phase detector frequency approximately between  $10 * \text{PLL loop bandwidth}$  and  $100 * \text{PLL loop bandwidth}$ . A phase detector frequency less than  $5 * \text{PLL bandwidth}$  may be unstable and a phase.

##### 3. PLL Loop Filter Design

- It is recommended to use the WEBENCH Clock Architect Tool to design your loop filter.
- Optimal loop filter design and simulation can be achieved when custom reference phase noise profiles are loaded into the software tool.
- While designing the loop filter, adjusting the charge pump current or N value can help with loop filter component selection. Lower charge pump currents and larger N values result in smaller component values but may increase impacts of leakage and reduce PLL phase noise performance.
- For a more detailed understanding of loop filter design can be found in Dean Banerjee's *PLL Performance, Simulation, and Design* ([www.ti.com/tool/pll\\_book](http://www.ti.com/tool/pll_book)).

##### 4. Device Programming

- The EVM programming software tool CodeLoader can be used to program the device with the desired configuration.

#### 9.2.3.2 Device Selection

Use the WEBENCH Clock Architect Tool. Enter the required output frequencies and formats into the tool. To use this device, find a solution using the LMK61E2.

#### 9.2.3.3 VCO Frequency Calculation

In this example, the VCO frequency of the LMK61E2 to generate 156.25 MHz can be calculated as 5 GHz.

## Typical Applications (continued)

### 9.2.3.4 Device Configuration

For this example, enter the desired output frequency and click on 'Generate Solutions'. Select LMK61E2 from the solution list. From the simulation page of the WEBENCH Clock Architect Tool, it can be seen that to maximize phase detector frequency, PLL R divider is set to 1, doubler is enabled and N divider is set to 50 for a PFD frequency of 100 MHz. This results in a VCO frequency of 5 GHz. At this point the design meets the output frequency requirements and it is possible to design a loop filter for system and simulate performance on the clock output.

### 9.2.3.5 PLL Loop Filter Design

In the WEBENCH Clock Architect Tool simulator, click on the PLL loop filter design button, then press recommend design. For the PLL loop filter, maximum phase detector frequency and maximum charge pump current are typically used. The tool recommends a loop filter that is designed to minimize jitter. The integrated loop filter's components are minimized with this recommendation as to allow maximum flexibility in achieving wide loop bandwidths for low PLL noise. With the recommended loop filter calculated, this loop filter is ready to be simulated.

The PLL loop filter's bode plot can additionally be viewed and adjustments can be made to the integrated components. The effective loop bandwidth and phase margin with the updated values is then calculated. The integrated loop filter components are good to use when attempting to eliminate certain spurs. The recommended procedure is to increase C3 capacitance, then R3 resistance. Large R3 resistance can result in degraded VCO phase noise performance.

### 9.2.3.6 Spur Mitigation Techniques

The LMK61E2 offers several programmable features for optimizing fractional spurs. In order to get the best out of these features, it makes sense to understand the different kinds of spurs as well as their behaviors, causes, and remedies. Although optimizing spurs may involve some trial and error, there are ways to make this process more systematic. TI offers the "Clock Design Tool" for more information and estimation of fractional spurs.

#### 9.2.3.6.1 Phase Detection Spur

The phase detector spur occurs at an offset from the carrier equal to the phase detector frequency,  $f_{PD}$ . To minimize this spur, a lower phase detector frequency should be considered. In some cases where the loop bandwidth is very wide relative to the phase detector frequency, some benefit might be gained from using a narrower loop bandwidth or adding poles to the loop filter by using R3 and C3 if previously unused, but otherwise the loop filter has minimal impact. Bypassing at the supply pins and board layout can also have an impact on this spur, especially at higher phase detector frequencies.

#### 9.2.3.6.2 Integer Boundary Fractional Spur

This spur occurs at an offset equal to the difference between the VCO frequency and the closest integer channel for the VCO. For instance, if the phase detector frequency is 100 MHz and the VCO frequency is 5003 MHz, then the integer boundary spur would be at 3 MHz offset. This spur can be either PLL or VCO dominated. If it is PLL dominated, decreasing the loop bandwidth and some of the programmable fractional words may impact this spur. If the spur is VCO dominated, then reducing the loop filter will not help, but rather reducing the phase detector and having good slew rate and signal integrity at the selected reference input will help.

#### 9.2.3.6.3 Primary Fractional Spur

These spurs occur at multiples of  $f_{PD}/DEN$  and are not the integer boundary spur. For instance, if the phase detector frequency is 100 MHz and the fraction is 3/100, the primary fractional spurs would be at 1 MHz, 2 MHz, 4 MHz, 5 MHz, 6 MHz etc. These are impacted by the loop filter bandwidth and modulator order. If a small frequency error is acceptable, then a larger equivalent fraction may improve these spurs. This larger unequivalent fraction pushes the fractional spur energy to much lower frequencies that where they are not impactful to the system performance.

## Typical Applications (continued)

### 9.2.3.6.4 Sub-Fractional Spur

These spurs appear at a fraction of  $f_{PD}/DEN$  and depend on modulator order. With the first order modulator, there are no sub-fractional spurs. The second order modulator can produce 1/2 sub-fractional spurs if the denominator is even. A third order modulator can produce sub-fractional spurs at 1/2, 1/3, or 1/6 of the offset, depending if it is divisible by 2 or 3. For instance, if the phase detector frequency is 100 MHz and the fraction is 3/100, no sub-fractional spurs for a first order modulator or sub-fractional spurs at multiples of 1.5 MHz for a second or third order modulator would be expected. Aside from strategically choosing the fractional denominator and using a lower order modulator, another tactic to eliminate these spurs is to use dithering and express the fraction in larger equivalent terms. Since dithering also adds phase noise, its level needs to be managed to achieve acceptable phase noise and spurious performance.

Table 2 gives a summary of the spurs discussed so far and techniques to mitigate them.

**Table 2. Spur and Mitigation Techniques**

SPUR TYPE	OFFSET	WAYS TO REDUCE	TRADE-OFFS
Phase Detector	$f_{PD}$	Reduce Phase Detector Frequency.	Although reducing the phase detector frequency does improve this spur, it also degrades phase noise.
Integer Boundary	$f_{VCO} \text{ mod } f_{PD}$	<b>Methods for PLL Dominated Spurs</b>	Reducing the loop bandwidth may degrade the total integrated noise if the bandwidth is too narrow.
		- Avoid the worst case VCO frequencies if possible.	
		- Ensure good slew rate and signal integrity at reference input.	
		- Reduce loop bandwidth or add more filter poles to suppress out of band spurs.	
		<b>Methods for VCO Dominated Spurs</b>	Reducing the phase detector may degrade the phase noise.
		- Avoid the worst case VCO frequencies if possible.	
		- Reduce Phase Detector Frequency.	
		- Ensure good slew rate and signal integrity at reference input.	
Primary Fractional	$f_{PD}/DEN$	- Decrease Loop Bandwidth.	Decreasing the loop bandwidth may degrade in-band phase noise. Also, larger unequivalent fractions don't always reduce spurs.
		- Change Modulator Order.	
		- Use Larger Unequivalent Fractions.	
Sub-Fractional	$f_{PD}/DEN/k$ k=2,3, or 6	- Use Dithering.	Dithering and larger fractions may increase phase noise.
		- Use Larger Equivalent Fractions.	
		- Use Larger Unequivalent Fractions.	
		- Reduce Modulator Order.	
		- Eliminate factors of 2 or 3 in denominator.	

## 10 Power Supply Recommendations

For best electrical performance of LMK61E2, it is preferred to utilize a combination of 10 uF, 1 uF and 0.1 uF on its power supply bypass network. It is also recommended to utilize component side mounting of the power supply bypass capacitors and it is best to use 0201 or 0402 body size capacitors to facilitate signal routing. Keep the connections between the bypass capacitors and the power supply on the device as short as possible. Ground the other side of the capacitor using a low impedance connection to the ground plane. [Figure 34](#) shows the layout recommendation for power supply decoupling of LMK61E2.

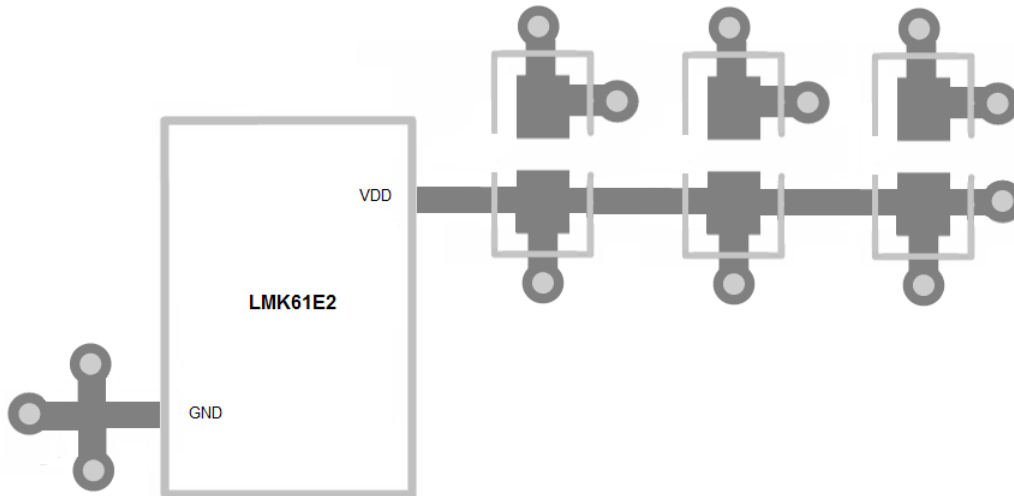

Figure 34. LMK61E2 Layout Recommendation for Power Supply and Ground

## 11 Layout

### 11.1 Layout Guidelines

The following sections provides recommendations for board layout, solder reflow profile and power supply bypassing when using LMK61E2 to ensure good thermal / electrical performance and overall signal integrity of entire system.

#### 11.1.1 Guarantee Thermal Reliability

The LMK61E2 is a high performance device. Therefore careful attention must be paid to device configuration and printed circuit board (PCB) layout with respect to power consumption. The ground pin needs to be connected to the ground plane of the PCB through three vias or more, as shown in [Figure 34](#), to maximize thermal dissipation out of the package.

[Equation 3](#) describes the relationship between the PCB temperature around the LMK61E2 and its junction temperature.

$$T_B = T_J - \Psi_{JB} * P$$

where

- $T_B$ : PCB temperature around the LMK61E2
  - $T_J$ : Junction temperature of LMK61E2
  - $\Psi_{JB}$ : Junction-to-board thermal resistance parameter of LMK61E2 (36.7°C/W without airflow)
  - $P$ : On-chip power dissipation of LMK61E2
- (3)

In order to ensure that the maximum junction temperature of LMK61E2 is below 125°C, it can be calculated that the maximum PCB temperature without airflow should be at 100°C or below when the device is optimized for best performance resulting in maximum on-chip power dissipation of 0.68 W.

#### 11.1.2 Best Practices for Signal Integrity

For best electrical performance and signal integrity of entire system with LMK61E2, it is recommended to route vias into decoupling capacitors and then into the LMK61E2. It is also recommended to increase the via count and width of the traces wherever possible. These steps ensure lowest impedance and shortest path for high frequency current flow. [Figure 34](#) shows the layout recommendation for LMK61E2.

#### 11.1.3 Recommended Solder Reflow Profile

It is recommended to follow the solder paste supplier's recommendations to optimize flux activity and to achieve proper melting temperatures of the alloy within the guidelines of J-STD-20. It is preferable for the LMK61E2 to be processed with the lowest peak temperature possible while also remaining below the components peak temperature rating as listed on the MSL label. The exact temperature profile would depend on several factors including maximum peak temperature for the component as rated on the MSL label, Board thickness, PCB material type, PCB geometries, component locations, sizes, densities within PCB, as well solder manufactures recommended profile, and capability of the reflow equipment to as confirmed by the SMT assembly operation.

## 12 Device and Documentation Support

### 12.1 Community Resources

The following links connect to TI community resources. Linked contents are provided "AS IS" by the respective contributors. They do not constitute TI specifications and do not necessarily reflect TI's views; see TI's [Terms of Use](#).

**TI E2E™ Online Community** *TI's Engineer-to-Engineer (E2E) Community*. Created to foster collaboration among engineers. At [e2e.ti.com](http://e2e.ti.com), you can ask questions, share knowledge, explore ideas and help solve problems with fellow engineers.

**Design Support** *TI's Design Support* Quickly find helpful E2E forums along with design support tools and contact information for technical support.

### 12.2 Trademarks

E2E is a trademark of Texas Instruments.

### 12.3 Electrostatic Discharge Caution



These devices have limited built-in ESD protection. The leads should be shorted together or the device placed in conductive foam during storage or handling to prevent electrostatic damage to the MOS gates.

### 12.4 Glossary

[SLYZ022](#) — *TI Glossary*.

This glossary lists and explains terms, acronyms, and definitions.

## 13 Mechanical, Packaging, and Orderable Information

The following pages include mechanical, packaging, and orderable information. This information is the most current data available for the designated devices. This data is subject to change without notice and revision of this document. For browser-based versions of this data sheet, refer to the left-hand navigation.

**PACKAGING INFORMATION**

Orderable Device	Status (1)	Package Type	Package Drawing	Pins	Package Qty	Eco Plan (2)	Lead/Ball Finish (6)	MSL Peak Temp (3)	Op Temp (°C)	Device Marking (4/5)	Samples
LMK61E2-SIAR	PREVIEW	QFM	SIA	8	2500	Green (RoHS & no Sb/Br)	Call TI	Level-3-260C-168 HR	-40 to 85	LMK61E2	
LMK61E2-SIAT	PREVIEW	QFM	SIA	8	250	Green (RoHS & no Sb/Br)	Call TI	Level-3-260C-168 HR	-40 to 85	LMK61E2	

(1) The marketing status values are defined as follows:

**ACTIVE:** Product device recommended for new designs.

**LIFEBUY:** TI has announced that the device will be discontinued, and a lifetime-buy period is in effect.

**NRND:** Not recommended for new designs. Device is in production to support existing customers, but TI does not recommend using this part in a new design.

**PREVIEW:** Device has been announced but is not in production. Samples may or may not be available.

**OBsolete:** TI has discontinued the production of the device.

(2) Eco Plan - The planned eco-friendly classification: Pb-Free (RoHS), Pb-Free (RoHS Exempt), or Green (RoHS & no Sb/Br) - please check <http://www.ti.com/productcontent> for the latest availability information and additional product content details.

**TBD:** The Pb-Free/Green conversion plan has not been defined.

**Pb-Free (RoHS):** TI's terms "Lead-Free" or "Pb-Free" mean semiconductor products that are compatible with the current RoHS requirements for all 6 substances, including the requirement that lead not exceed 0.1% by weight in homogeneous materials. Where designed to be soldered at high temperatures, TI Pb-Free products are suitable for use in specified lead-free processes.

**Pb-Free (RoHS Exempt):** This component has a RoHS exemption for either 1) lead-based flip-chip solder bumps used between the die and package, or 2) lead-based die adhesive used between the die and leadframe. The component is otherwise considered Pb-Free (RoHS compatible) as defined above.

**Green (RoHS & no Sb/Br):** TI defines "Green" to mean Pb-Free (RoHS compatible), and free of Bromine (Br) and Antimony (Sb) based flame retardants (Br or Sb do not exceed 0.1% by weight in homogeneous material)

(3) MSL, Peak Temp. - The Moisture Sensitivity Level rating according to the JEDEC industry standard classifications, and peak solder temperature.

(4) There may be additional marking, which relates to the logo, the lot trace code information, or the environmental category on the device.

(5) Multiple Device Markings will be inside parentheses. Only one Device Marking contained in parentheses and separated by a "~" will appear on a device. If a line is indented then it is a continuation of the previous line and the two combined represent the entire Device Marking for that device.

(6) Lead/Ball Finish - Orderable Devices may have multiple material finish options. Finish options are separated by a vertical ruled line. Lead/Ball Finish values may wrap to two lines if the finish value exceeds the maximum column width.

**Important Information and Disclaimer:** The information provided on this page represents TI's knowledge and belief as of the date that it is provided. TI bases its knowledge and belief on information provided by third parties, and makes no representation or warranty as to the accuracy of such information. Efforts are underway to better integrate information from third parties. TI has taken and continues to take reasonable steps to provide representative and accurate information but may not have conducted destructive testing or chemical analysis on incoming materials and chemicals. TI and TI suppliers consider certain information to be proprietary, and thus CAS numbers and other limited information may not be available for release.

In no event shall TI's liability arising out of such information exceed the total purchase price of the TI part(s) at issue in this document sold by TI to Customer on an annual basis.

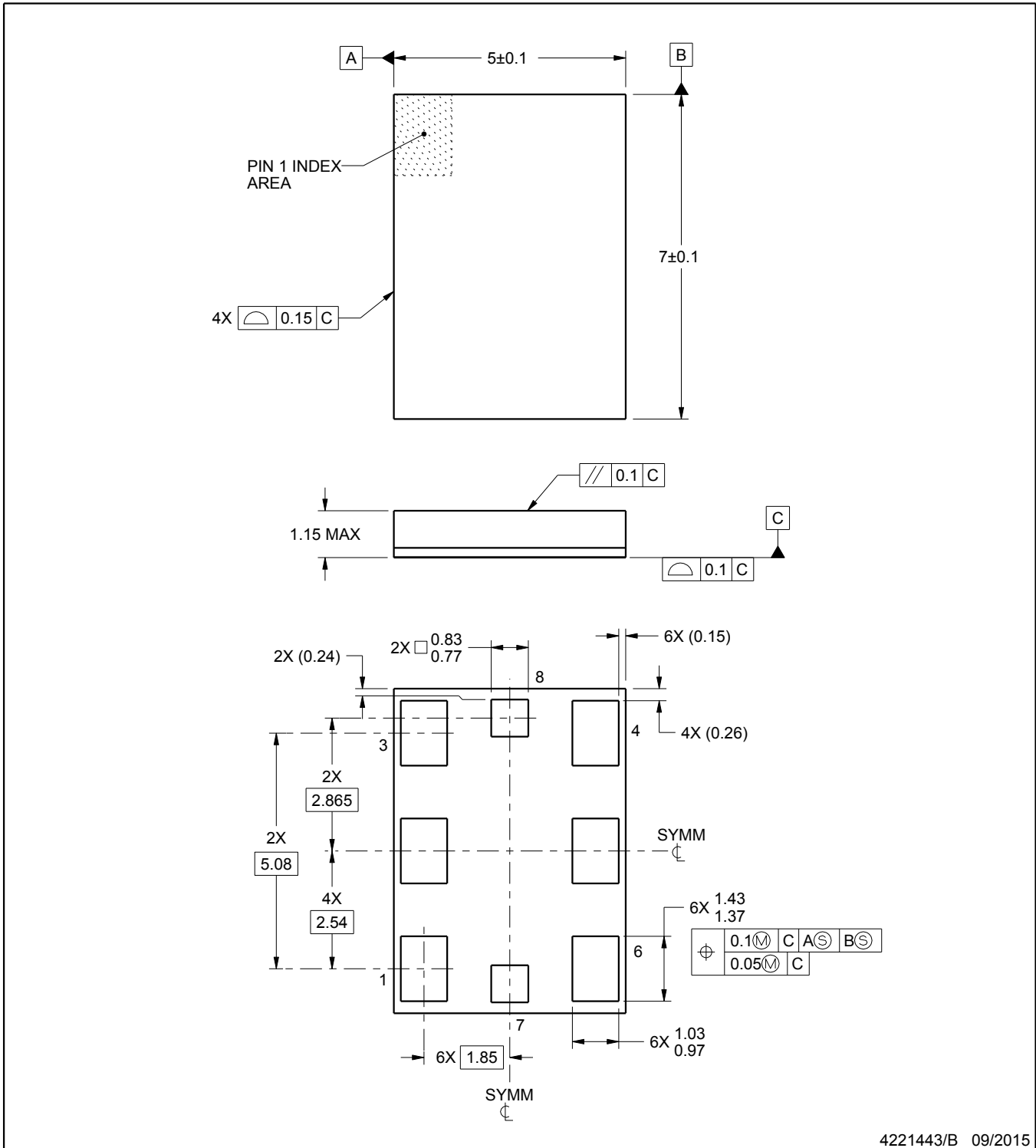
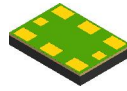

4221443/B 09/2015

NOTES:

1. All linear dimensions are in millimeters. Any dimensions in parenthesis are for reference only. Dimensioning and tolerancing per ASME Y14.5M.
2. This drawing is subject to change without notice.

# EXAMPLE BOARD LAYOUT

SIA0008B

QFM - 1.15 mm max height

QUAD FLAT MODULE

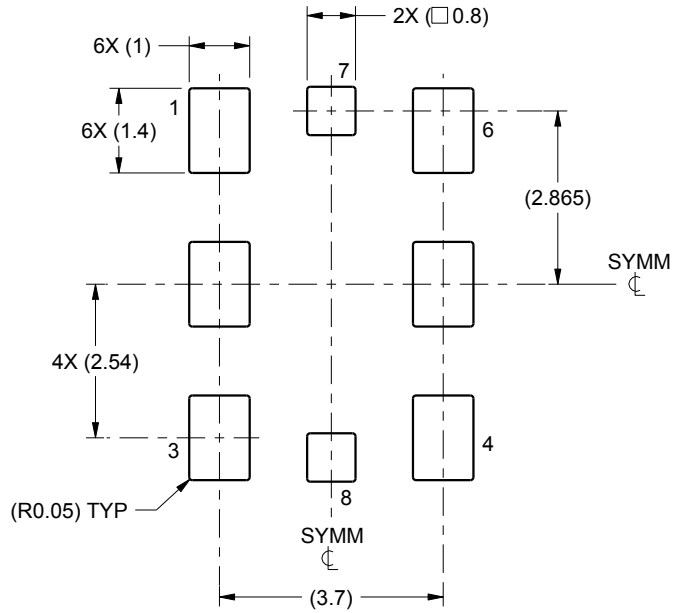

LAND PATTERN EXAMPLE  
1:1 RATIO WITH PACKAGE SOLDER PADS  
SCALE:8X

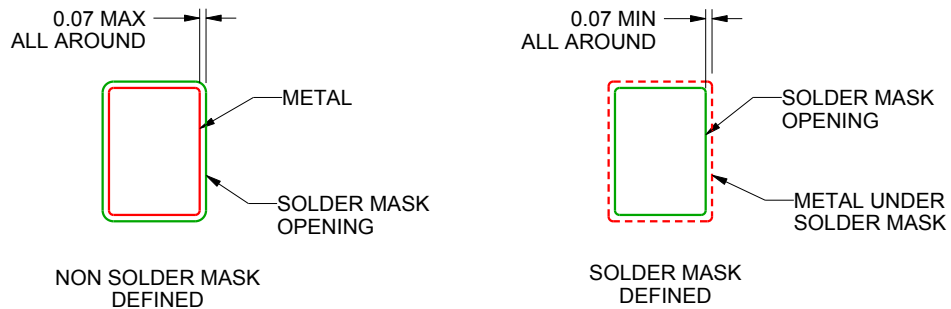

SOLDER MASK DETAILS  
NOT TO SCALE

4221443/B 09/2015

NOTES: (continued)

3. For more information, see Texas Instruments literature number SLUA271 ([www.ti.com/lit/sluea271](http://www.ti.com/lit/sluea271)).

# EXAMPLE STENCIL DESIGN

SIA0008B

QFM - 1.15 mm max height

QUAD FLAT MODULE

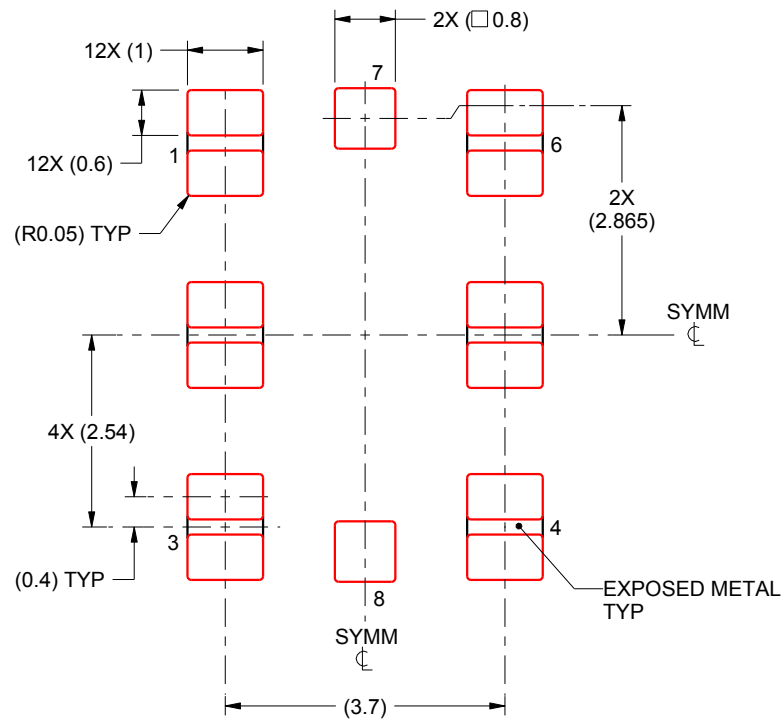

SOLDER PASTE EXAMPLE  
BASED ON 0.125 mm THICK STENCIL  
PRINTED SOLDER COVERAGE BY AREA  
PADS 1-3 & 4-6: 86%  
SCALE:10X

4221443/B 09/2015

NOTES: (continued)

4. Laser cutting apertures with trapezoidal walls and rounded corners may offer better paste release. IPC-7525 may have alternate design recommendations.

## IMPORTANT NOTICE

Texas Instruments Incorporated and its subsidiaries (TI) reserve the right to make corrections, enhancements, improvements and other changes to its semiconductor products and services per JESD46, latest issue, and to discontinue any product or service per JESD48, latest issue. Buyers should obtain the latest relevant information before placing orders and should verify that such information is current and complete. All semiconductor products (also referred to herein as "components") are sold subject to TI's terms and conditions of sale supplied at the time of order acknowledgment.

TI warrants performance of its components to the specifications applicable at the time of sale, in accordance with the warranty in TI's terms and conditions of sale of semiconductor products. Testing and other quality control techniques are used to the extent TI deems necessary to support this warranty. Except where mandated by applicable law, testing of all parameters of each component is not necessarily performed.

TI assumes no liability for applications assistance or the design of Buyers' products. Buyers are responsible for their products and applications using TI components. To minimize the risks associated with Buyers' products and applications, Buyers should provide adequate design and operating safeguards.

TI does not warrant or represent that any license, either express or implied, is granted under any patent right, copyright, mask work right, or other intellectual property right relating to any combination, machine, or process in which TI components or services are used. Information published by TI regarding third-party products or services does not constitute a license to use such products or services or a warranty or endorsement thereof. Use of such information may require a license from a third party under the patents or other intellectual property of the third party, or a license from TI under the patents or other intellectual property of TI.

Reproduction of significant portions of TI information in TI data books or data sheets is permissible only if reproduction is without alteration and is accompanied by all associated warranties, conditions, limitations, and notices. TI is not responsible or liable for such altered documentation. Information of third parties may be subject to additional restrictions.

Resale of TI components or services with statements different from or beyond the parameters stated by TI for that component or service voids all express and any implied warranties for the associated TI component or service and is an unfair and deceptive business practice. TI is not responsible or liable for any such statements.

Buyer acknowledges and agrees that it is solely responsible for compliance with all legal, regulatory and safety-related requirements concerning its products, and any use of TI components in its applications, notwithstanding any applications-related information or support that may be provided by TI. Buyer represents and agrees that it has all the necessary expertise to create and implement safeguards which anticipate dangerous consequences of failures, monitor failures and their consequences, lessen the likelihood of failures that might cause harm and take appropriate remedial actions. Buyer will fully indemnify TI and its representatives against any damages arising out of the use of any TI components in safety-critical applications.

In some cases, TI components may be promoted specifically to facilitate safety-related applications. With such components, TI's goal is to help enable customers to design and create their own end-product solutions that meet applicable functional safety standards and requirements. Nonetheless, such components are subject to these terms.

No TI components are authorized for use in FDA Class III (or similar life-critical medical equipment) unless authorized officers of the parties have executed a special agreement specifically governing such use.

Only those TI components which TI has specifically designated as military grade or "enhanced plastic" are designed and intended for use in military/aerospace applications or environments. Buyer acknowledges and agrees that any military or aerospace use of TI components which have **not** been so designated is solely at the Buyer's risk, and that Buyer is solely responsible for compliance with all legal and regulatory requirements in connection with such use.

TI has specifically designated certain components as meeting ISO/TS16949 requirements, mainly for automotive use. In any case of use of non-designated products, TI will not be responsible for any failure to meet ISO/TS16949.

### Products

Audio	<a href="http://www.ti.com/audio">www.ti.com/audio</a>
Amplifiers	<a href="http://amplifier.ti.com">amplifier.ti.com</a>
Data Converters	<a href="http://dataconverter.ti.com">dataconverter.ti.com</a>
DLP® Products	<a href="http://www.dlp.com">www.dlp.com</a>
DSP	<a href="http://dsp.ti.com">dsp.ti.com</a>
Clocks and Timers	<a href="http://www.ti.com/clocks">www.ti.com/clocks</a>
Interface	<a href="http://interface.ti.com">interface.ti.com</a>
Logic	<a href="http://logic.ti.com">logic.ti.com</a>
Power Mgmt	<a href="http://power.ti.com">power.ti.com</a>
Microcontrollers	<a href="http://microcontroller.ti.com">microcontroller.ti.com</a>
RFID	<a href="http://www.ti-rfid.com">www.ti-rfid.com</a>
OMAP Applications Processors	<a href="http://www.ti.com/omap">www.ti.com/omap</a>
Wireless Connectivity	<a href="http://www.ti.com/wirelessconnectivity">www.ti.com/wirelessconnectivity</a>

### Applications

Automotive and Transportation	<a href="http://www.ti.com/automotive">www.ti.com/automotive</a>
Communications and Telecom	<a href="http://www.ti.com/communications">www.ti.com/communications</a>
Computers and Peripherals	<a href="http://www.ti.com/computers">www.ti.com/computers</a>
Consumer Electronics	<a href="http://www.ti.com/consumer-apps">www.ti.com/consumer-apps</a>
Energy and Lighting	<a href="http://www.ti.com/energy">www.ti.com/energy</a>
Industrial	<a href="http://www.ti.com/industrial">www.ti.com/industrial</a>
Medical	<a href="http://www.ti.com/medical">www.ti.com/medical</a>
Security	<a href="http://www.ti.com/security">www.ti.com/security</a>
Space, Avionics and Defense	<a href="http://www.ti.com/space-avionics-defense">www.ti.com/space-avionics-defense</a>
Video and Imaging	<a href="http://www.ti.com/video">www.ti.com/video</a>

### TI E2E Community

[e2e.ti.com](http://e2e.ti.com)