

150-mA 100-V Step-Down Switching Regulator

Check for Samples: [LM5009](#)

FEATURES

- **Integrated N-Channel MOSFET**
- **150-mA output current capability**
- **Ultra-Fast Transient Response**
- **No loop compensation required**
- **Vin feed forward provides constant operating frequency**
- **Switching frequency can exceed 600 kHz**
- **Highly efficient operation**
- **2% accurate 2.5V feedback from -40°C to 125°C**
- **Internal startup regulator**
- **Intelligent current limit protection**
- **External shutdown control**
- **Thermal shutdown**
- **8-Pin VSSOP and thermally enhanced 8-Pin WSON packages**

APPLICATIONS

- **Heat sink eliminator for classic linear regulator applications**
- **12V, 24V, 36V, and 48V rectified AC systems**
- **42V Automotive**
- **Non-isolated AC mains charge coupled supplies**
- **LED Current Source**

DESCRIPTION

The LM5009 Step Down Switching Regulator features all of the functions needed to implement a low cost, efficient, Buck bias regulator. This device is capable of driving a 150 mA load current from a 9.5V to 95V input source. The switching frequency can exceed 600 kHz, depending on the input and output voltages. The output voltage may be set from 2.5V to 85V. This high voltage regulator contains an N-Channel buck switch and internal startup regulator. The device is easy to implement and is provided in the 8-pin VSSOP and the thermally enhanced 8-pin WSON packages. The LM5009 is a well suited alternative to a high voltage monolithic or discrete linear solution where the power loss becomes unacceptable. The regulator's operation is based on a control scheme using an ON time inversely proportional to VIN. This feature allows the operating frequency to remain relatively constant over load and input voltage variations. The control scheme requires no loop compensation, resulting in an ultra-fast transient response. An intelligent current limit is implemented with forced OFF time, which is inversely proportional to Vout. This scheme ensures short circuit protection while providing minimum foldback. Other features include: Thermal Shutdown, Vcc under-voltage lockout, Gate drive under-voltage lockout, and Maximum Duty Cycle limiter.

Typical Application Circuit

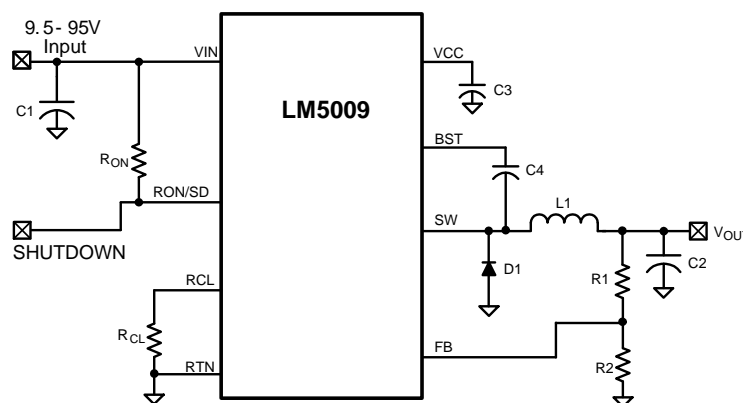

Figure 1. Basic Step-Down Regulator



Please be aware that an important notice concerning availability, standard warranty, and use in critical applications of Texas Instruments semiconductor products and disclaimers thereto appears at the end of this data sheet.

All trademarks are the property of their respective owners.

Connection Diagram

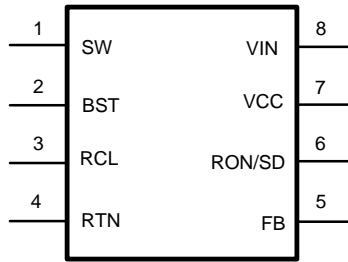

Figure 2. 8-Lead VSSOP or WSON

Pin Functions

Table 1. Pin Descriptions

Pin	Name	Description	Application Information
1	SW	Switching output	Power switching output. Connect to the inductor, re-circulating diode, and bootstrap capacitor.
2	BST	Boost Pin	An external capacitor is required between the BST and the SW pins. A 0.022 μF ceramic capacitor is recommended. An internal diode charges the capacitor from V_{CC} .
3	RCL	Current Limit off-time set pin	A resistor between this pin and RTN sets the off-time when current limit is detected. The off-time is preset to 35 μs if $\text{FB} = 0\text{V}$.
4	RTN	Ground pin	Ground for the entire circuit.
5	FB	Feedback input from Regulated Output	This pin is connected to the inverting input of the internal regulation comparator. The regulation threshold is 2.5V.
6	RON/SD	On-time set pin	A resistor between this pin and V_{IN} sets the switch on-time as a function of V_{IN} . The minimum recommended on-time is 250ns at the maximum input voltage. This pin can be used for remote shutdown.
7	VCC	Output from the internal high voltage startup regulator. Regulated at 7.0V.	If an auxiliary voltage is available to raise the voltage on this pin above the regulation set point (7V), the internal series pass regulator will shutdown, reducing the IC power dissipation. Do not exceed 14V. This voltage provides gate drive power for the internal Buck switch. An internal diode is provided between this pin and the BST pin. A local 0.1 μF decoupling capacitor is required.
8	VIN	Input voltage	Recommended operating range: 9.5V to 95V.
	EP	Exposed pad (WSON package only)	Exposed metal pad on the underside of the device. It is recommended to connect this to the PC board ground plane to aid in heat dissipation.



These devices have limited built-in ESD protection. The leads should be shorted together or the device placed in conductive foam during storage or handling to prevent electrostatic damage to the MOS gates.

Absolute Maximum Ratings⁽¹⁾

V_{IN} to RTN	-0.3V to 100V
BST to RTN	-0.3V to 114V
SW to RTN (Steady State)	-1V
ESD Rating, Human Body Model ⁽²⁾	2kV
BST to VCC	100V
BST to SW	14V
VCC to RTN	14V
All Other Inputs to RTN	-0.3 to 7V
Storage Temperature Range	-65°C to +150°C

(1) Absolute Maximum Ratings are limits beyond which damage to the device may occur. Operating Ratings are conditions under which operation of the device is intended to be functional. For specifications and test conditions, see the Electrical Characteristics.

(2) The human body model is a 100pF capacitor discharged through a 1.5k Ω resistor into each pin.

Operating Ratings⁽¹⁾

V_{IN}	9.5V to 95V
Operating Junction Temperature	-40°C to + 125°C

- (1) Absolute Maximum Ratings are limits beyond which damage to the device may occur. Operating Ratings are conditions under which operation of the device is intended to be functional. For specifications and test conditions, see the Electrical Characteristics.

Electrical Characteristics

Limits in standard type are for $T_J = 25^\circ\text{C}$ only, and limits in **boldface type** apply over the junction temperature (T_J) range of -40°C to $+125^\circ\text{C}$. Minimum and Maximum limits are specified through test, design, or statistical correlation. Typical values represent the most likely parametric norm at $T_J = 25^\circ\text{C}$, and are provided for reference purposes only. Unless otherwise stated, the following conditions apply: $V_{IN} = 48\text{V}$, $R_{ON} = 200\text{k}\Omega$. See ⁽¹⁾

Symbol	Parameter	Conditions	Min	Typ	Max	Unit
V_{CC} Supply						
V _{CC} Reg	V _{CC} Regulator Output		6.6	7	7.4	V
	V _{CC} Current Limit ⁽²⁾			9.5		mA
	V _{CC} undervoltage Lockout Voltage (V _{CC} increasing)			6.3		V
	V _{CC} Undervoltage Hysteresis			200		mV
	V _{CC} UVLO Delay (filter)	100mV overdrive		10		μs
	I _{IN} Operating Current	Non-Switching, FB = 3V		485	675	μA
	I _{IN} Shutdown Current	RON/SD = 0V		76	150	μA
Switch Characteristics						
	Buck Switch Rds(on)	I _{TEST} = 200mA ⁽³⁾		2.0	4.4	Ω
	Gate Drive UVLO	V _{BST} - V _{SW} Rising	3.4	4.5	5.5	V
	Gate Drive UVLO Hysteresis			430		mV
Current Limit						
	Current Limit Threshold		0.25	0.31	0.37	A
	Current Limit Response Time	I _{switch} Overdrive = 0.1A Time to Switch Off		400		ns
	OFF time generator (test 1)	FB=0V, R _{CL} = 100K		35		μs
	OFF time generator (test 2)	FB=2.3V, R _{CL} = 100K		2.56		μs
On Time Generator						
	T _{ON} - 1	V _{in} = 10V, R _{on} = 200K	2.15	2.77	3.5	μs
	T _{ON} - 2	V _{in} = 95V, R _{on} = 200K	200	300	420	ns
	Remote Shutdown Threshold	Rising	0.40	0.70	1.05	V
	Remote Shutdown Hysteresis			35		mV
Minimum Off Time						
	Minimum Off Timer	FB = 0V		300		ns
Regulation and OV Comparators						
	FB Reference Threshold	Internal reference, Trip point for switch ON	2.445	2.5	2.550	V
	FB Over-Voltage Threshold	Trip point for switch OFF		2.875		V
	FB Bias Current			1		nA
Thermal Shutdown						
T _{sd}	Thermal Shutdown Temperature			165		°C
	Thermal Shutdown Hysteresis			25		°C
Thermal Resistance						
θ _{JA}	Junction to Ambient	VSSOP Package		200		°C/W
		WSOP Package		40		°C/W

- (1) All electrical characteristics having room temperature limits are tested during production with $T_A = T_J = 25^\circ\text{C}$. All hot and cold limits are specified by correlating the electrical characteristics to process and temperature variations and applying statistical process control.
- (2) The V_{CC} output is intended as a self bias for the internal gate drive power and control circuits. Device thermal limitations limit external loading.
- (3) For devices procured in the WSON-8 package, the Rds(on) limits are specified by design characterization data only.

Typical Performance Characteristics

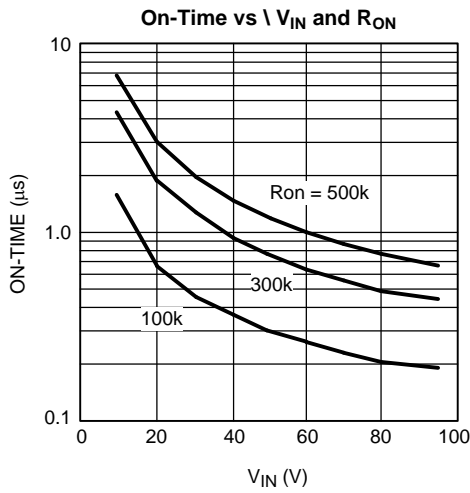

Figure 3.

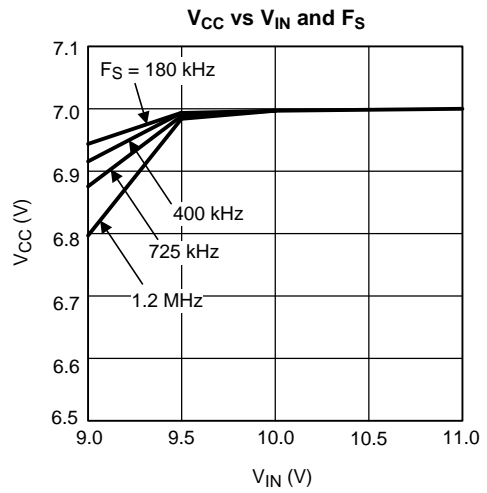

Figure 4.

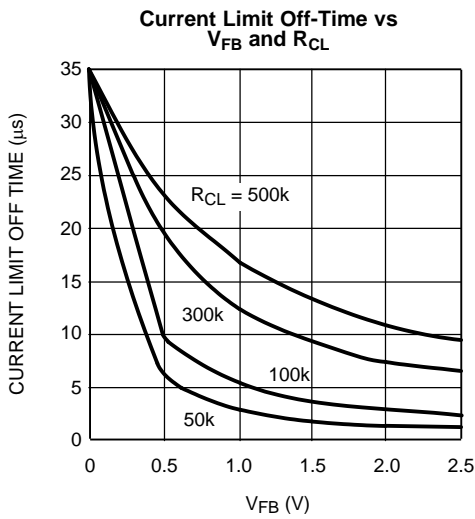

Figure 5.

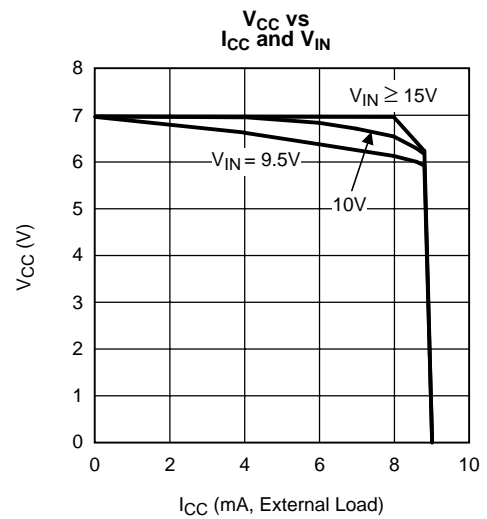

Figure 6.

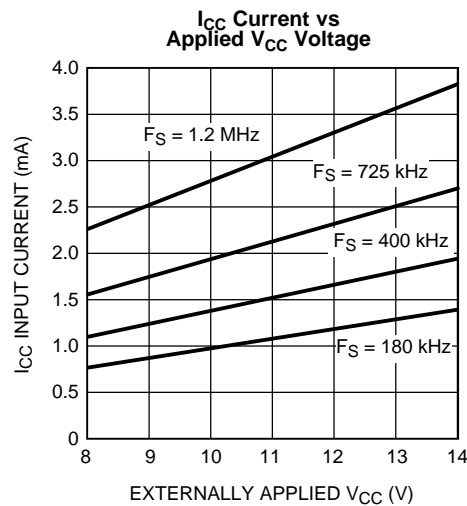

Figure 7.

TYPICAL APPLICATION CIRCUIT AND BLOCK DIAGRAM

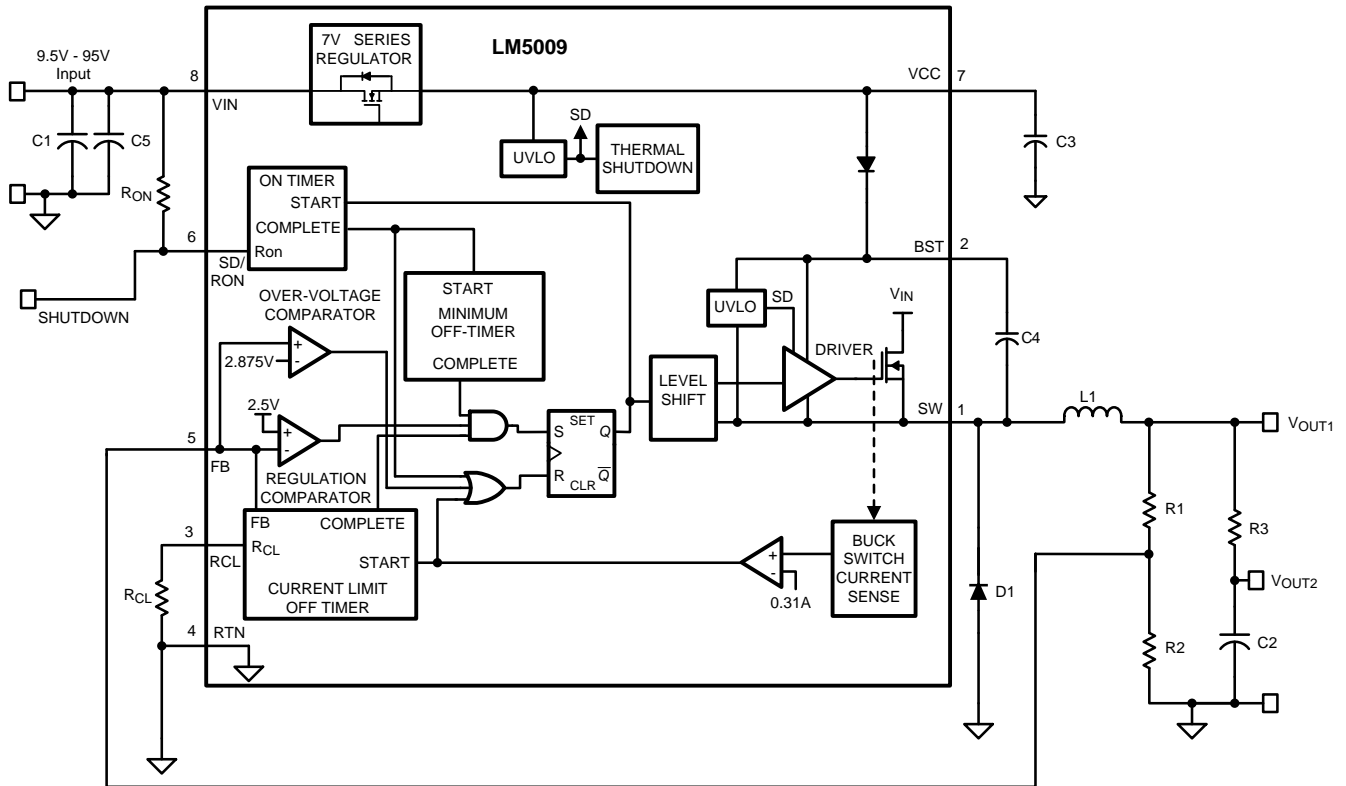

Figure 8.

FUNCTIONAL DESCRIPTION

The LM5009 Step Down Switching Regulator features all the functions needed to implement a low cost, efficient, Buck bias power converter. This high voltage regulator contains a 100 V N-Channel Buck Switch, is easy to implement and is provided in the VSSOP-8 and the thermally enhanced WSON-8 packages. The regulator is based on a control scheme using an on-time inversely proportional to V_{IN} . The control scheme requires no loop compensation. Current limit is implemented with forced off-time, which is inversely proportional to V_{OUT} . This scheme ensures short circuit protection while providing minimum foldback. The Functional Block Diagram of the LM5009 is shown in [Figure 8](#).

The LM5009 can be applied in numerous applications to efficiently regulate down higher voltages. This regulator is well suited for 48 Volt Telecom and the 42V Automotive power bus ranges. Additional features include: Thermal Shutdown, V_{CC} under-voltage lockout, Gate drive under-voltage lockout, Max Duty Cycle limit timer and the intelligent current limit off timer.

Control Circuit Overview

The LM5009 is a Buck DC-DC regulator that uses a control scheme in which the on-time varies inversely with line voltage (V_{IN}). Control is based on a comparator and the on-time one-shot, with the output voltage feedback (FB) compared to an internal reference (2.5V). If the FB level is below the reference the buck switch is turned on for a fixed time determined by the line voltage and a programming resistor (R_{ON}). Following the ON period the switch will remain off for at least the minimum off-timer period of 300 ns. If FB is still below the reference at that time the switch will turn on again for another on-time period. This will continue until regulation is achieved, at which time the off-time increases based on the required duty cycle.

The LM5009 operates in discontinuous conduction mode at light load currents, and continuous conduction mode at heavy load current. In discontinuous conduction mode, current through the output inductor starts at zero and ramps up to a peak during the on-time, then ramps back to zero before the end of the off-time. The next on-time period starts when the voltage at FB falls below the internal reference - until then the inductor current remains zero. In this mode the operating frequency is lower than in continuous conduction mode, and varies with load current. Therefore at light loads the conversion efficiency is maintained, since the switching losses reduce with the reduction in load and frequency. The discontinuous operating frequency can be calculated as follows:

$$F = \frac{V_{OUT}^2 \times L \times 1.28 \times 10^{20}}{R_L \times (R_{ON})^2} \quad (1)$$

where R_L = the load resistance

In continuous conduction mode, current flows continuously through the inductor and never ramps down to zero. In this mode the operating frequency is greater than the discontinuous mode frequency and remains relatively constant with load and line variations. The approximate continuous mode operating frequency can be calculated as follows:

$$F = \frac{V_{OUT}}{1.25 \times 10^{-10} \times R_{ON}} \quad (2)$$

The output voltage (V_{OUT}) is programmed by two external resistors as shown in [Figure 8](#). The regulation point is calculated as follows:

$$V_{OUT} = 2.5 \times (R1 + R2) / R2 \quad (3)$$

This regulator regulates the output voltage based on ripple voltage at the feedback input, requiring a minimum amount of ESR for the output capacitor C2. A minimum of 25mV of ripple voltage at the feedback pin (FB) is required for the LM5009. In cases where the capacitor ESR is too small, additional series resistance may be required (R3 in [Figure 8](#)).

For applications where lower output voltage ripple is required the output can be taken directly from a low ESR output capacitor, as shown in [Figure 9](#). However, R3 slightly degrades the load regulation.

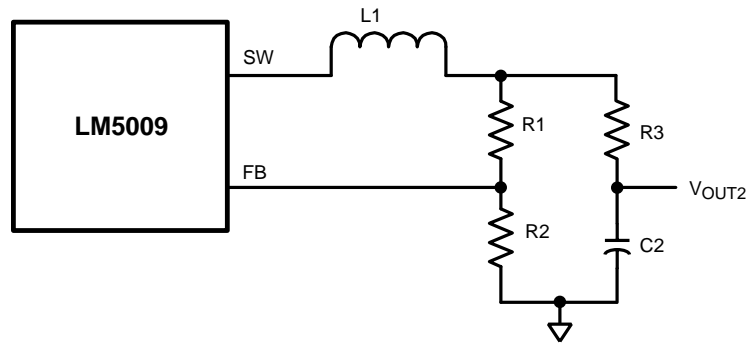

Figure 9. Low Ripple Output Configuration

High Voltage Start-Up Regulator

The LM5009 contains an internal high voltage start-up regulator. The input pin (V_{IN}) can be connected directly to line voltages up to 95 Volts, with transient capability to 100 volts. The regulator is internally current limited at 9.5mA. Upon power up, the regulator sources current into the external capacitor at V_{CC} ($C3$). When the voltage on the V_{CC} pin reaches the under-voltage lockout threshold of 6.3V, the buck switch is enabled.

In applications involving a high value for V_{IN} , where power dissipation in the V_{CC} regulator is a concern, an auxiliary voltage can be diode connected to the V_{CC} pin. Setting the voltage between 8V and 14V shuts off the internal regulator, reducing internal power dissipation. See Figure 10. The current required into the V_{CC} pin is shown in the Typical Performance Characteristics.

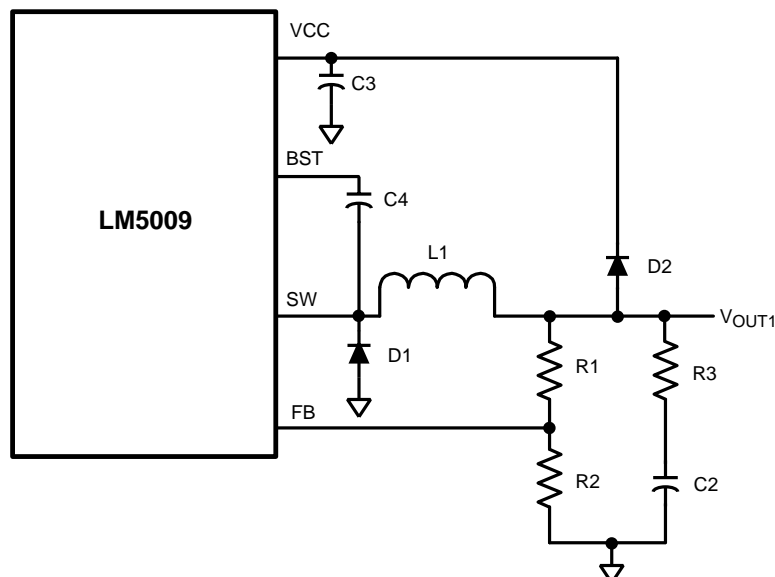

Figure 10. Self-Biased Configuration

Regulation Comparator

The feedback voltage at FB is compared to an internal 2.5V reference. In normal operation (the output voltage is regulated), an on-time period is initiated when the voltage at FB falls below 2.5V. The buck switch will stay on for the programmed on-time, causing the FB voltage to rise above 2.5V. After the on-time period, the buck switch will stay off until the FB voltage again falls below 2.5V. During start-up, the FB voltage will be below 2.5V at the end of each on-time, resulting in the minimum off-time. Bias current at the FB pin is less than 5 nA over temperature.

Over-Voltage Comparator

The feedback voltage at FB is compared to an internal 2.875V reference. If the voltage at FB rises above 2.875V the on-time pulse is immediately terminated. This condition can occur if the input voltage, or the output load, change suddenly. The buck switch will not turn on again until the voltage at FB falls below 2.5V.

ON-Time Generator and Shutdown

The on-time for the LM5009 is determined by the R_{ON} resistor, and is inversely proportional to the input voltage (V_{IN}), resulting in a nearly constant frequency as V_{IN} is varied over its range. The on-time equation is:

$$T_{ON} = 1.25 \times 10^{-10} \times R_{ON} / V_{IN} \quad (4)$$

R_{ON} should be selected for a minimum on-time (at maximum V_{IN}) greater than 250 ns, for proper current limit operation. This requirement limits the maximum frequency for each application, depending on V_{IN} and V_{OUT} .

The LM5009 can be remotely disabled by taking the RON/SD pin to ground. See Figure 11. The voltage at the RON/SD pin is between 1.7V and 5V, depending on V_{IN} and the value of the R_{ON} resistor.

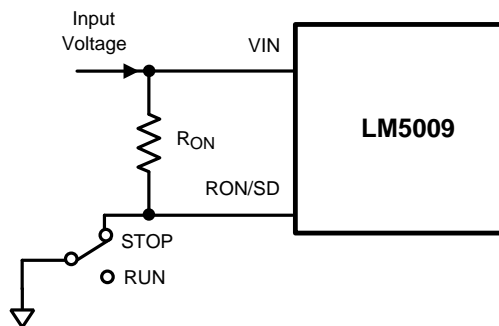

Figure 11. Shutdown Implementation

Current Limit

The LM5009 contains an intelligent current limit OFF timer. If the current in the Buck switch exceeds 0.31A the present cycle is immediately terminated, and a non-resettable OFF timer is initiated. The length of off-time is controlled by an external resistor (R_{CL}) and the FB voltage. When $FB = 0V$, a maximum off-time is required, and the time is preset to 35 μ s. This condition occurs when the output is shorted, and during the initial part of start-up. This amount of time ensures safe short circuit operation up to the maximum input voltage of 95V. In cases of overload where the FB voltage is above zero volts (not a short circuit) the current limit off-time will be less than 35 μ s. Reducing the off-time during less severe overloads reduces the amount of foldback, recovery time, and the start-up time. The off-time is calculated from the following equation:

$$T_{OFF} = \frac{10^{-5}}{0.285 + \frac{V_{FB}}{(6.35 \times 10^{-6} \times R_{CL})}} \quad (5)$$

The current limit sensing circuit is blanked for the first 50-70ns of each on-time so it is not falsely tripped by the current surge which occurs at turn-on. The current surge is required by the re-circulating diode (D1) for its turn-off recovery.

N-Channel Buck Switch and Driver

The LM5009 integrates an N-Channel buck switch and associated floating high voltage gate driver. The gate driver circuit works in conjunction with an external bootstrap capacitor and an internal high voltage diode. A 0.022- μ F ceramic capacitor (C4) connected between the BST pin and SW pin provides the voltage to the driver during the on-time.

During each off-time, the SW pin is at approximately -1V, and the bootstrap capacitor charges from V_{CC} through the internal diode. The minimum OFF timer ensures a minimum time each cycle to recharge the bootstrap capacitor.

An external re-circulating diode (D1) carries the inductor current after the internal buck switch turns off. This diode should be of the ultra-fast or Schottky type to minimize turn-on losses and current over-shoot.

Thermal Protection

The LM5009 should be operated so the junction temperature does not exceed 125°C during normal operation. An internal Thermal Shutdown circuit is provided to protect the LM5009 in the event of a higher than normal junction temperature. When activated, typically at 165°C, the controller is forced into a low power reset state, disabling the buck switch. This feature prevents catastrophic failures from accidental device overheating. When the junction temperature reduces below 140°C (typical hysteresis = 25°C), the buck switch is enabled, and normal operation is resumed.

APPLICATIONS INFORMATION

SELECTION OF EXTERNAL COMPONENTS

A guide for determining the component values will be illustrated with a design example. Refer to [Figure 8](#). The following steps will configure the LM5009 for:

- Input voltage range (V_{in}): 12V to 90V
- Output voltage (V_{OUT1}): 10V
- Load current (for continuous conduction mode): 100mA to 150mA

R1 and R2: From [Figure 8](#), $V_{OUT1} = V_{FB} \times (R1 + R2) / R2$, and since $V_{FB} = 2.5V$, the ratio of R1 to R2 calculates as 3:1. Standard values of 3.01 k Ω (R1) and 1.00 k Ω (R2) are chosen. Other values could be used as long as the 3:1 ratio is maintained. The selected values, however, provide a small amount of output loading (2.5 mA) in the event the main load is disconnected. This allows the circuit to maintain regulation until the main load is reconnected.

F_s and R_{ON}: Unless the application requires a specific frequency, the choice of frequency is generally a compromise since it affects the size of L1 and C2, and the switching losses. The maximum allowed frequency, based on a minimum on-time of 250 ns, is calculated from:

$$F_{MAX} = V_{OUT} / (V_{INMAX} \times 250 \text{ ns}) \quad (6)$$

For this exercise, $F_{max} = 444 \text{ kHz}$. From [Equation 2](#), R_{ON} calculates to 180 k Ω . A standard value 237 k Ω resistor will be used to allow for tolerances in [Equation 2](#), resulting in a nominal frequency of 337 kHz.

L1: The main parameter affected by the inductor is the output current ripple amplitude. The choice of inductor value therefore depends on both the minimum and maximum load currents, keeping in mind that the maximum ripple current occurs at maximum V_{in} .

a) **Minimum load current:** To maintain continuous conduction at minimum I_o (100 mA), the ripple amplitude (I_{OR}) must be less than 200 mA peak-to-peak so the lower peak of the waveform does not reach zero. L1 is calculated using the following equation:

$$L1 = \frac{V_{OUT1} \times (V_{IN} - V_{OUT1})}{I_{OR} \times F_s \times V_{IN}} \quad (7)$$

At $V_{in} = 90V$, $L1(\text{min})$ calculates to 132 μH . The next larger standard value (150 μH) is chosen and with this value I_{OR} calculates to 176 mA peak-to-peak at $V_{in} = 90V$, and 33 mA peak-to-peak at $V_{in} = 12V$.

b) **Maximum load current:** At a load current of 150 mA, the peak of the ripple waveform must not reach the minimum value of the LM5009's current limit threshold (250 mA). Therefore the ripple amplitude must be less than 200 mA peak-to-peak, which is already satisfied in the above calculation. With $L1 = 150 \mu\text{H}$, at maximum V_{in} and I_o , the peak of the ripple will be 238 mA. While L1 must carry this peak current without saturating or exceeding its temperature rating, it also must be capable of carrying the maximum value of the LM5009's current limit threshold (370 mA) without saturating, since the current limit is reached during startup.

C3: The capacitor on the V_{CC} output provides not only noise filtering and stability, but also prevents false triggering of the V_{CC} UVLO at the buck switch on/off transitions. For this reason, C3 should be no smaller than 0.1 μF .

C2, and R3: When selecting the output filter capacitor C2, the items to consider are ripple voltage due to its ESR, ripple voltage due to its capacitance, and the nature of the load.

a) **ESR and R3:** A low ESR for C2 is generally desirable so as to minimize power losses and heating within the capacitor. However, this regulator requires a minimum amount of ripple voltage at the feedback input for proper loop operation. For the LM5009 the minimum ripple required at pin 5 is 25 mV peak-to-peak, requiring a minimum ripple at V_{OUT1} of 100 mV. Since the minimum ripple current (at minimum V_{in}) is 33 mA peak-to-peak, the minimum ESR required at V_{OUT1} is 3 Ω . Since quality capacitors for SMPS applications have an ESR considerably less than this, R3 is inserted as shown in [Figure 8](#). R3's value, along with C2's ESR, must result in at least 25 mV peak-to-peak ripple at pin 5. Generally, R3 will be 0.5 Ω to 5.0 Ω .

b) **Nature of the Load:** The load can be connected to V_{OUT1} or V_{OUT2} . V_{OUT1} provides good regulation, but with a ripple voltage which ranges from 100 mV (at $V_{in} = 12V$) to 580 mV (at $V_{in} = 90V$). Alternatively, V_{OUT2} provides low ripple (3 mV to 13 mV) but lower regulation due to R3.

C2 should generally be no smaller than 3.3 μF . Typically, its value is 10 μF to 20 μF , with the optimum value determined by the load. If the load current is fairly constant, a small value suffices for C2. If the load current includes significant transients, a larger value is necessary. For each application, experimentation is needed to determine the optimum values for R3 and C2.

C) Ripple Reduction: The ripple amplitude at V_{OUT1} can be reduced by reducing R3, and adding a capacitor across R1 so as to transfer the ripple at V_{OUT1} directly to the FB pin, without attenuation. The new value of R3 is calculated from:

$$R3 = 25 \text{ mV} / I_{\text{OR}(\text{min})} \quad (8)$$

where $I_{\text{OR}(\text{min})}$ is the minimum ripple current amplitude - 33 mA p-p in this example. The added capacitor's value is calculated from:

$$C = T_{\text{ON}(\text{max})} / (R1 \parallel R2) \quad (9)$$

where $T_{\text{ON}(\text{max})}$ is the maximum on-time (at minimum V_{in}). The selected capacitor should be larger than the value calculated above.

R_{CL}: When a current limit condition is detected, the minimum off-time set by this resistor must be greater than the maximum normal off-time which occurs at maximum V_{in} . Using Equation 4, the minimum on-time is 0.329 μs , yielding a maximum off-time of 2.63 μs . This is increased by 82 ns (to 2.72 μs) due to a $\pm 25\%$ tolerance of the on-time. This value is then increased to allow for:

The response time of the current limit detection loop (400ns).

The off-time determined by Equation 5 has a $\pm 25\%$ tolerance:

$$t_{\text{OFFCL}(\text{MIN})} = (2.72 \mu\text{s} \times 1.25) + 0.4 \mu\text{s} = 3.8 \mu\text{s} \quad (10)$$

Using Equation 5, R_{CL} calculates to 167 k Ω (at $V_{\text{FB}} = 2.5\text{V}$). The closest standard value is 169 k Ω .

D1: The important parameters are reverse recovery time and forward voltage. The reverse recovery time determines how long the reverse current surge lasts each time the buck switch is turned on. The forward voltage drop is significant in the event the output is short-circuited as it is only this diode's voltage which forces the inductor current to reduce during the forced off-time. For this reason, a higher voltage is better, although that affects efficiency. A good choice is an ultrafast power or Schottky diode with a reverse recovery time of ≈ 30 ns, and a forward voltage drop of $\approx 0.7\text{V}$. Other types of diodes may have a lower forward voltage drop, but may have longer recovery times, or greater reverse leakage. D1's reverse voltage rating must be at least as great as the maximum V_{in} , and its current rating be greater than the maximum current limit threshold (370 mA).

C1: This capacitor's purpose is to supply most of the switch current during the on-time, and limit the voltage ripple at V_{IN} , on the assumption that the voltage source feeding V_{IN} has an output impedance greater than zero. At maximum load current, when the buck switch turns on, the current into pin 8 will suddenly increase to the lower peak of the output current waveform, ramp up to the peak value, then drop to zero at turn-off. The average input current during this on-time is the load current (150 mA). For a worst case calculation, C1 must supply this average load current during the maximum on-time. To keep the input voltage ripple to less than 2V (for this exercise), C1 calculates to:

$$C1 = \frac{I \times t_{\text{ON}}}{\Delta V} = \frac{0.15\text{A} \times 2.47 \mu\text{s}}{2.0\text{V}} = 0.185 \mu\text{F} \quad (11)$$

Quality ceramic capacitors in this value have a low ESR which adds only a few millivolts to the ripple. It is the capacitance which is dominant in this case. To allow for the capacitor's tolerance, temperature effects, and voltage effects, a 1.0 μF , 100V, X7R capacitor will be used.

C4: The recommended value is 0.022 μF for C4, as this is appropriate in the majority of applications. A high quality ceramic capacitor, with low ESR is recommended as C4 supplies the surge current to charge the buck switch gate at turn-on. A low ESR also ensures a quick recharge during each off-time. At minimum V_{IN} , when the on-time is at maximum, it is possible during start-up that C4 will not fully recharge during each 300 ns off-time. The circuit will not be able to complete the start-up, and achieve output regulation. This can occur when the frequency is intended to be low (e.g., $R_{\text{ON}} = 500\text{K}$). In this case C4 should be increased so it can maintain sufficient voltage across the buck switch driver during each on-time.

C5: This capacitor helps avoid supply voltage transients and ringing due to long lead inductance at V_{IN} . A low ESR, 0.1 μF ceramic chip capacitor is recommended, located close to the LM5009.

FINAL CIRCUIT

The final circuit is shown in [Figure 12](#). The circuit was tested, and the resulting performance is shown in [Figure 13](#) through [Figure 16](#). For these graphs, the load current was varied from 50mA to 200mA.

MINIMUM LOAD CURRENT

A minimum load current of 1 mA is required to maintain proper operation. If the load current falls below that level, the bootstrap capacitor may discharge during the long off-time, and the circuit will either shutdown, or cycle on and off at a low frequency. If the load current is expected to drop below 1 mA in the application, the feedback resistors should be chosen low enough in value so they provide the minimum required current at nominal V_{out} .

PC BOARD LAYOUT

The LM5009 regulation and over-voltage comparators are very fast, and as such will respond to short duration noise pulses. Layout considerations are therefore critical for optimum performance. The components at pins 1, 2, 3, 5, and 6 should be as physically close as possible to the IC, thereby minimizing noise pickup in the PC tracks. The current loop formed by D1, L1, and C2 should be as small as possible. The ground connection from C2 to C1 should be as short and direct as possible.

If the internal dissipation of the LM5009 produces excessive junction temperatures during normal operation, good use of the PC board's ground plane can help considerably to dissipate heat. The exposed pad on the bottom of the WSON-8 package can be soldered to a ground plane on the PC board, and that plane should extend out from beneath the IC to help dissipate the heat. Additionally, the use of wide PC board traces, where possible, can also help conduct heat away from the IC. Judicious positioning of the PC board within the end product, along with use of any available air flow (forced or natural convection) can help reduce the junction temperatures.

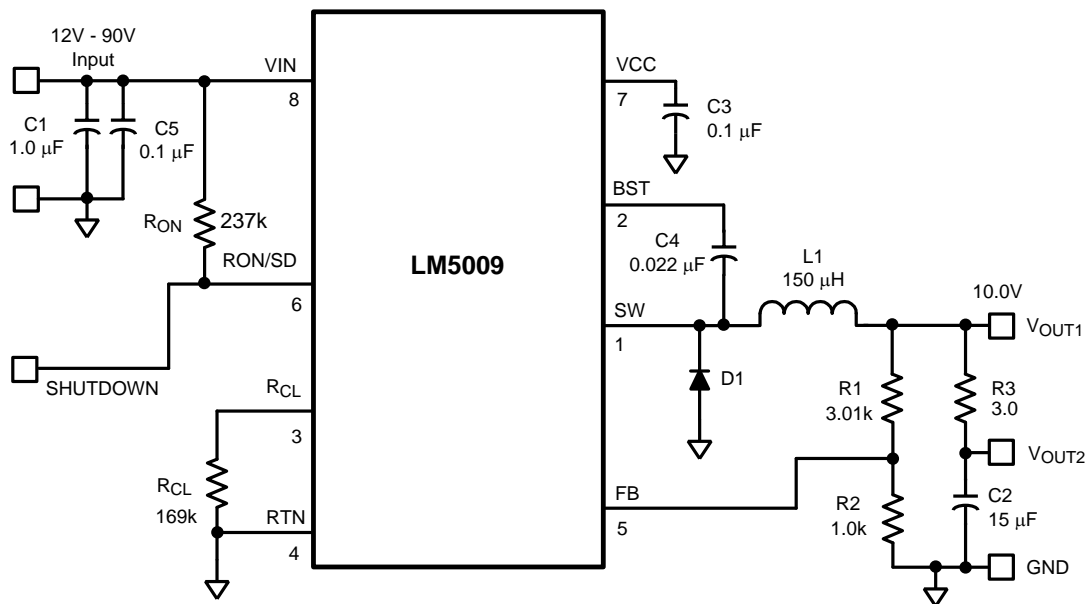

Figure 12. LM5009 Example Circuit

Table 2. Bill of Materials (Circuit of Figure 12)

Item	Description	Part Number	Value
C1	Ceramic Capacitor	TDK C4532X7R2A105M	1 μ F, 100V
C2	Ceramic Capacitor	TDK C4532X7R1E156M	15 μ F, 25V
C3	Ceramic Capacitor	Kemet C1206C104K5RAC	0.1 μ F, 50V
C4	Ceramic Capacitor	Kemet C1206C223K5RAC	0.022 μ F, 50V
C5	Ceramic Capacitor	TDK C3216X7R2A104M	0.1 μ F, 100V
D1	Schottky Power Diode	Diodes Inc. DFSL1100	100V, 1A
L1	Power Inductor	TDK SLF7045T-151MR33	150 μ H
R1	Resistor	Vishay CRCW12063011F	3.01 k Ω
R2	Resistor	Vishay CRCW12061001F	1.0 k Ω
R3	Resistor	Vishay CRCW12063R00F	3.0 Ω
R _{ON}	Resistor	Vishay CRCW12062373F	237 k Ω
R _{CL}	Resistor	Vishay CRCW12061693F	169 k Ω
U1	Switching Regulator	LM5009	

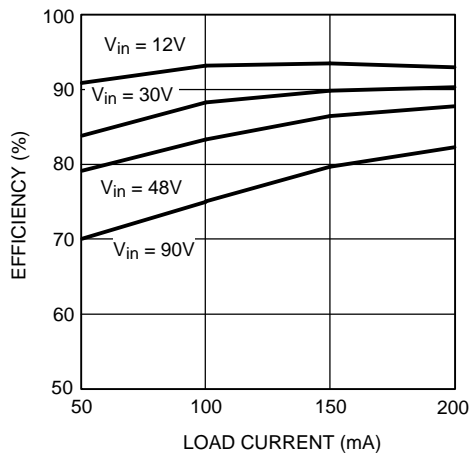

Figure 13. Efficiency vs Load Current and V_{IN}

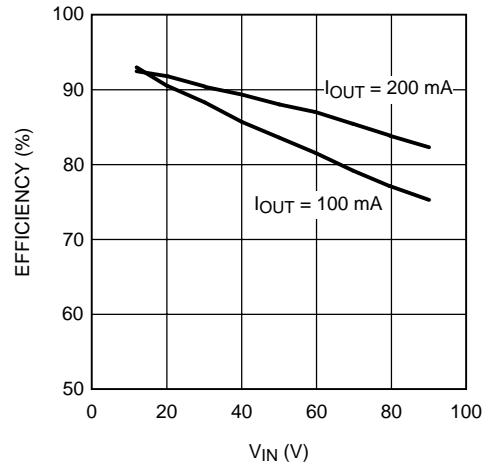

Figure 14. Efficiency vs V_{IN} and Load Current

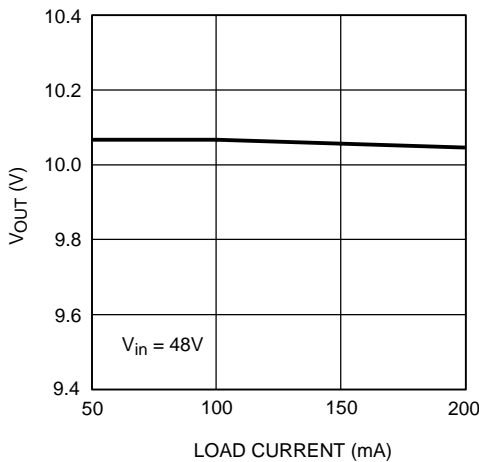

Figure 15. V_{OUT} vs Load Current

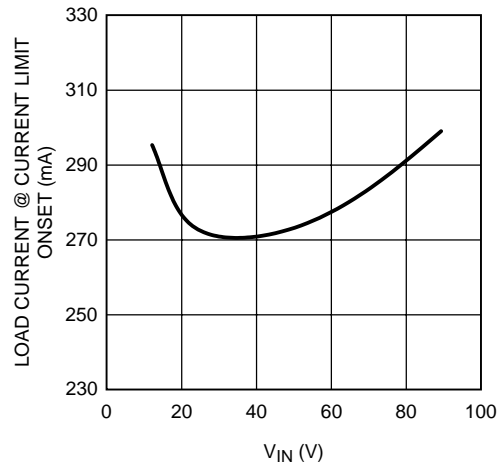

Figure 16. Current Limit vs V_{IN}

REVISION HISTORY

Changes from Revision F (February 2013) to Revision G	Page
<hr/> <ul style="list-style-type: none">• Changed layout of National Data Sheet to TI format	<hr/> 14

PACKAGING INFORMATION

Orderable Device	Status (1)	Package Type	Package Drawing	Pins	Package Qty	Eco Plan (2)	Lead/Ball Finish	MSL Peak Temp (3)	Op Temp (°C)	Top-Side Markings (4)	Samples
LM5009MM	ACTIVE	VSSOP	DGK	8	1000	TBD	Call TI	Call TI	-40 to 125	SLLB	Samples
LM5009MM/NOPB	ACTIVE	VSSOP	DGK	8	1000	Green (RoHS & no Sb/Br)	CU SN	Level-1-260C-UNLIM	-40 to 125	SLLB	Samples
LM5009MMX	ACTIVE	VSSOP	DGK	8	3500	TBD	Call TI	Call TI	-40 to 125	SLLB	Samples
LM5009MMX/NOPB	ACTIVE	VSSOP	DGK	8	3500	Green (RoHS & no Sb/Br)	CU SN	Level-1-260C-UNLIM	-40 to 125	SLLB	Samples
LM5009SDC	ACTIVE	WSON	NGU	8	1000	TBD	Call TI	Call TI	-40 to 125	5009SD	Samples
LM5009SDC/NOPB	ACTIVE	WSON	NGU	8	1000	Green (RoHS & no Sb/Br)	CU SN	Level-1-260C-UNLIM	-40 to 125	5009SD	Samples
LM5009SDCX	ACTIVE	WSON	NGU	8	4500	TBD	Call TI	Call TI	-40 to 125	5009SD	Samples
LM5009SDCX/NOPB	ACTIVE	WSON	NGU	8	4500	Green (RoHS & no Sb/Br)	CU SN	Level-1-260C-UNLIM	-40 to 125	5009SD	Samples

(1) The marketing status values are defined as follows:

ACTIVE: Product device recommended for new designs.

LIFEBUY: TI has announced that the device will be discontinued, and a lifetime-buy period is in effect.

NRND: Not recommended for new designs. Device is in production to support existing customers, but TI does not recommend using this part in a new design.

PREVIEW: Device has been announced but is not in production. Samples may or may not be available.

OBSOLETE: TI has discontinued the production of the device.

(2) Eco Plan - The planned eco-friendly classification: Pb-Free (RoHS), Pb-Free (RoHS Exempt), or Green (RoHS & no Sb/Br) - please check <http://www.ti.com/productcontent> for the latest availability information and additional product content details.

TBD: The Pb-Free/Green conversion plan has not been defined.

Pb-Free (RoHS): TI's terms "Lead-Free" or "Pb-Free" mean semiconductor products that are compatible with the current RoHS requirements for all 6 substances, including the requirement that lead not exceed 0.1% by weight in homogeneous materials. Where designed to be soldered at high temperatures, TI Pb-Free products are suitable for use in specified lead-free processes.

Pb-Free (RoHS Exempt): This component has a RoHS exemption for either 1) lead-based flip-chip solder bumps used between the die and package, or 2) lead-based die adhesive used between the die and leadframe. The component is otherwise considered Pb-Free (RoHS compatible) as defined above.

Green (RoHS & no Sb/Br): TI defines "Green" to mean Pb-Free (RoHS compatible), and free of Bromine (Br) and Antimony (Sb) based flame retardants (Br or Sb do not exceed 0.1% by weight in homogeneous material)

(3) MSL, Peak Temp. -- The Moisture Sensitivity Level rating according to the JEDEC industry standard classifications, and peak solder temperature.

(4) Only one of markings shown within the brackets will appear on the physical device.

Important Information and Disclaimer: The information provided on this page represents TI's knowledge and belief as of the date that it is provided. TI bases its knowledge and belief on information provided by third parties, and makes no representation or warranty as to the accuracy of such information. Efforts are underway to better integrate information from third parties. TI has taken and continues to take reasonable steps to provide representative and accurate information but may not have conducted destructive testing or chemical analysis on incoming materials and chemicals. TI and TI suppliers consider certain information to be proprietary, and thus CAS numbers and other limited information may not be available for release.

In no event shall TI's liability arising out of such information exceed the total purchase price of the TI part(s) at issue in this document sold by TI to Customer on an annual basis.

TAPE AND REEL INFORMATION

QUADRANT ASSIGNMENTS FOR PIN 1 ORIENTATION IN TAPE

*All dimensions are nominal

Device	Package Type	Package Drawing	Pins	SPQ	Reel Diameter (mm)	Reel Width W1 (mm)	A0 (mm)	B0 (mm)	K0 (mm)	P1 (mm)	W (mm)	Pin1 Quadrant
LM5009MM	VSSOP	DGK	8	1000	178.0	12.4	5.3	3.4	1.4	8.0	12.0	Q1
LM5009MM/NOPB	VSSOP	DGK	8	1000	178.0	12.4	5.3	3.4	1.4	8.0	12.0	Q1
LM5009MMX	VSSOP	DGK	8	3500	330.0	12.4	5.3	3.4	1.4	8.0	12.0	Q1
LM5009MMX/NOPB	VSSOP	DGK	8	3500	330.0	12.4	5.3	3.4	1.4	8.0	12.0	Q1
LM5009SDC	WSOP	NGU	8	1000	178.0	12.4	4.3	4.3	1.3	8.0	12.0	Q1
LM5009SDC/NOPB	WSOP	NGU	8	1000	178.0	12.4	4.3	4.3	1.3	8.0	12.0	Q1
LM5009SDCX	WSOP	NGU	8	4500	330.0	12.4	4.3	4.3	1.3	8.0	12.0	Q1
LM5009SDCX/NOPB	WSOP	NGU	8	4500	330.0	12.4	4.3	4.3	1.3	8.0	12.0	Q1

TAPE AND REEL BOX DIMENSIONS



*All dimensions are nominal

Device	Package Type	Package Drawing	Pins	SPQ	Length (mm)	Width (mm)	Height (mm)
LM5009MM	VSSOP	DGK	8	1000	203.0	190.0	41.0
LM5009MM/NOPB	VSSOP	DGK	8	1000	203.0	190.0	41.0
LM5009MMX	VSSOP	DGK	8	3500	349.0	337.0	45.0
LM5009MMX/NOPB	VSSOP	DGK	8	3500	349.0	337.0	45.0
LM5009SDC	WSON	NGU	8	1000	203.0	190.0	41.0
LM5009SDC/NOPB	WSON	NGU	8	1000	203.0	190.0	41.0
LM5009SDCX	WSON	NGU	8	4500	349.0	337.0	45.0
LM5009SDCX/NOPB	WSON	NGU	8	4500	349.0	337.0	45.0

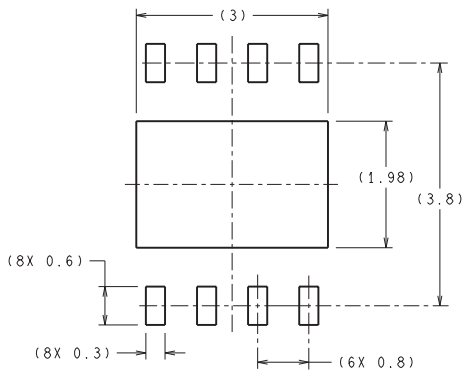
NGU0008B

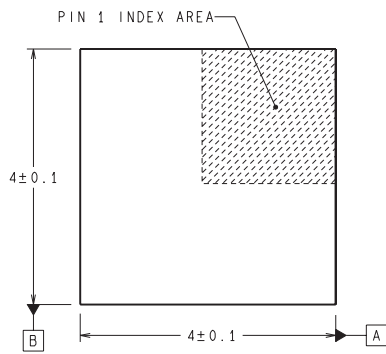

RECOMMENDED LAND PATTERN



DIMENSIONS ARE IN MILLIMETERS
DIMENSIONS IN () FOR REFERENCE ONLY

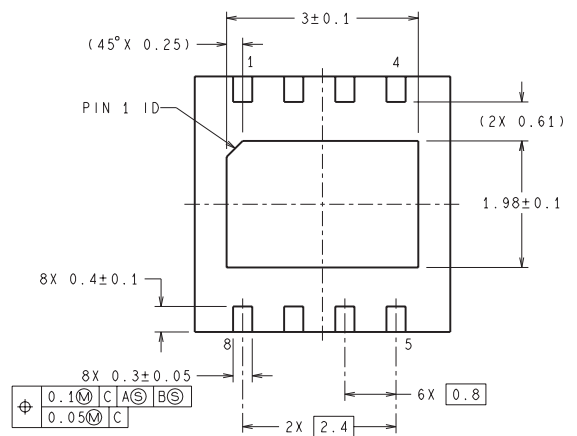
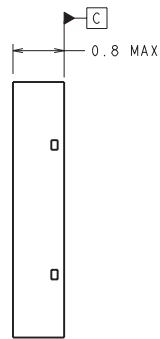
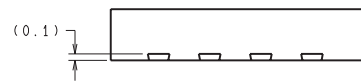

⊕	0.1	M	C	A	⊗	B	⊗
	0.05	M	C				

SDC08B (Rev A)

IMPORTANT NOTICE

Texas Instruments Incorporated and its subsidiaries (TI) reserve the right to make corrections, enhancements, improvements and other changes to its semiconductor products and services per JESD46, latest issue, and to discontinue any product or service per JESD48, latest issue. Buyers should obtain the latest relevant information before placing orders and should verify that such information is current and complete. All semiconductor products (also referred to herein as "components") are sold subject to TI's terms and conditions of sale supplied at the time of order acknowledgment.

TI warrants performance of its components to the specifications applicable at the time of sale, in accordance with the warranty in TI's terms and conditions of sale of semiconductor products. Testing and other quality control techniques are used to the extent TI deems necessary to support this warranty. Except where mandated by applicable law, testing of all parameters of each component is not necessarily performed.

TI assumes no liability for applications assistance or the design of Buyers' products. Buyers are responsible for their products and applications using TI components. To minimize the risks associated with Buyers' products and applications, Buyers should provide adequate design and operating safeguards.

TI does not warrant or represent that any license, either express or implied, is granted under any patent right, copyright, mask work right, or other intellectual property right relating to any combination, machine, or process in which TI components or services are used. Information published by TI regarding third-party products or services does not constitute a license to use such products or services or a warranty or endorsement thereof. Use of such information may require a license from a third party under the patents or other intellectual property of the third party, or a license from TI under the patents or other intellectual property of TI.

Reproduction of significant portions of TI information in TI data books or data sheets is permissible only if reproduction is without alteration and is accompanied by all associated warranties, conditions, limitations, and notices. TI is not responsible or liable for such altered documentation. Information of third parties may be subject to additional restrictions.

Resale of TI components or services with statements different from or beyond the parameters stated by TI for that component or service voids all express and any implied warranties for the associated TI component or service and is an unfair and deceptive business practice. TI is not responsible or liable for any such statements.

Buyer acknowledges and agrees that it is solely responsible for compliance with all legal, regulatory and safety-related requirements concerning its products, and any use of TI components in its applications, notwithstanding any applications-related information or support that may be provided by TI. Buyer represents and agrees that it has all the necessary expertise to create and implement safeguards which anticipate dangerous consequences of failures, monitor failures and their consequences, lessen the likelihood of failures that might cause harm and take appropriate remedial actions. Buyer will fully indemnify TI and its representatives against any damages arising out of the use of any TI components in safety-critical applications.

In some cases, TI components may be promoted specifically to facilitate safety-related applications. With such components, TI's goal is to help enable customers to design and create their own end-product solutions that meet applicable functional safety standards and requirements. Nonetheless, such components are subject to these terms.

No TI components are authorized for use in FDA Class III (or similar life-critical medical equipment) unless authorized officers of the parties have executed a special agreement specifically governing such use.

Only those TI components which TI has specifically designated as military grade or "enhanced plastic" are designed and intended for use in military/aerospace applications or environments. Buyer acknowledges and agrees that any military or aerospace use of TI components which have **not** been so designated is solely at the Buyer's risk, and that Buyer is solely responsible for compliance with all legal and regulatory requirements in connection with such use.

TI has specifically designated certain components as meeting ISO/TS16949 requirements, mainly for automotive use. In any case of use of non-designated products, TI will not be responsible for any failure to meet ISO/TS16949.

Products

Audio	www.ti.com/audio
Amplifiers	amplifier.ti.com
Data Converters	dataconverter.ti.com
DLP® Products	www.dlp.com
DSP	dsp.ti.com
Clocks and Timers	www.ti.com/clocks
Interface	interface.ti.com
Logic	logic.ti.com
Power Mgmt	power.ti.com
Microcontrollers	microcontroller.ti.com
RFID	www.ti-rfid.com
OMAP Applications Processors	www.ti.com/omap
Wireless Connectivity	www.ti.com/wirelessconnectivity

Applications

Automotive and Transportation	www.ti.com/automotive
Communications and Telecom	www.ti.com/communications
Computers and Peripherals	www.ti.com/computers
Consumer Electronics	www.ti.com/consumer-apps
Energy and Lighting	www.ti.com/energy
Industrial	www.ti.com/industrial
Medical	www.ti.com/medical
Security	www.ti.com/security
Space, Avionics and Defense	www.ti.com/space-avionics-defense
Video and Imaging	www.ti.com/video

TI E2E Community

e2e.ti.com