

# LM3553 1.2A Dual Flash LED Driver System with I<sup>2</sup>C Compatible Interface

Check for Samples: [LM3553](#)

## FEATURES

- Accurate and Programmable LED Current up to 1.2A in 128 Steps
- Total Solution Size < 30mm<sup>2</sup>
- 90% Peak Efficiency
- Drives 2 LEDs in Series with 1.2A from 5V Input
- Drives 2 LEDs in Series with 600mA from 3.0V Input
- Drives 1 LED with 1.2A from 3.0V Input
- Adjustable Over-Voltage Protection Allows for Single or Series LED Operation
- Four Operating Modes: Torch, Flash, Indicator, and Voltage Mode (4.98V)
- Programmable Flash Pulse Safety Timer in 16 Steps
- TX Input Ensures Synchronization with RF Power Amplifier Pulse or Prevents LED from Overheating
- LED Disconnect During Shutdown
- Flash/Imager Synchronization via F<sub>EN</sub> Pin
- Active Low Hardware Reset

- Multi-Function Pin ( $\overline{\text{RESET}}$  and GPIO)
- Low Profile 12-pin WSON Package (DQB0012A: 3mm x 3mm x 0.8mm, 0.4mm pitch)

## APPLICATIONS

- Camera Phone LED Flash
- Smartphone and PDA Flash
- LED Backlight

## DESCRIPTION

The LM3553 is a fixed frequency, current mode step-up DC/DC converter with two regulated current sinks. The device is capable of driving loads up to 1.2A from a single-cell Li-Ion battery.

The LM3553 includes a TX pin that forces Torch mode during a flash event allowing for synchronization between the RF power amplifier and Flash/Torch modes. It also includes a multi-function pin (M/F) that can serve as a GPIO and a hardware RESET pin.

The LM3553 is available in a 3mm by 3mm package.

## Typical Application Circuits

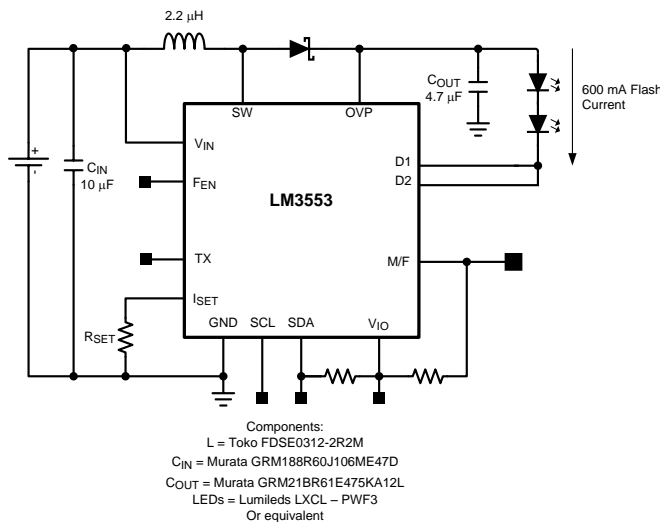
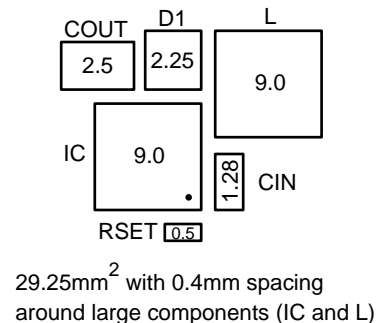
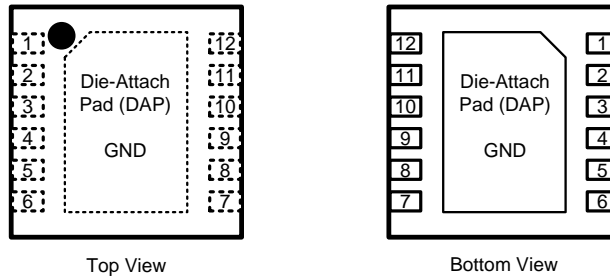

**Figure 1.**

**Figure 2. Solution Size**

Please be aware that an important notice concerning availability, standard warranty, and use in critical applications of Texas Instruments semiconductor products and disclaimers thereto appears at the end of this data sheet.

All trademarks are the property of their respective owners.

## Connection Diagram

### 12 Pin 3mm x 3mm WSON Package DQB0012A



### PIN DESCRIPTIONS

Pin	Name	Function
4	$V_{IN}$	Input Voltage. Input range: 2.7V to 5.5V.
5	SW	Switch Pin
6	OVP	Over Voltage Protection Pin
2, 11	D1, D2	Regulated current sink inputs
DAP	GND	Ground
1	$I_{SET}$	Current sense input. Connect a 1% 16.5k $\Omega$ resistor to ground to set the full scale LED current.
3	$F_{EN}$	Flash enable pin.
8	SCL	Serial clock pin.
10	SDA	Serial data I/O pin.
9	VIO	Digital Reference Voltage level input pin.
7	TX	RF PA synchronization control pin. High = Forced Torch mode.
12	M/F	Hardware RESET or General purpose I/O. Function set through Multi-Function Control Register



These devices have limited built-in ESD protection. The leads should be shorted together or the device placed in conductive foam during storage or handling to prevent electrostatic damage to the MOS gates.

### Absolute Maximum Ratings <sup>(1)(2)(3)</sup>

$V_{IN}$ pin: Voltage to GND	-0.3V to 6V
SW, OVP pin: Voltage to GND	-0.3V to 25V
D1, D2 pins: Voltage to GND	-0.3V to 25V
VIO, SCL, SDA	-0.3V to 6V
TX, FEN, M/F	-0.3V to 6V
Continuous Power Dissipation <sup>(4)</sup>	Internally Limited
Junction Temperature ( $T_{J-MAX}$ )	150°C
Storage Temperature Range	-65°C to +150
Maximum Lead Temperature (Soldering)	<sup>(5)</sup>
ESD Rating <sup>(6)</sup> Human Body Model	2.5kV

- (1) Absolute Maximum Ratings indicate limits beyond which damage to the component may occur. Operating Ratings are conditions under which operation of the device is specified. Operating Ratings do not imply performance limits. For performance limits and associated test conditions, see the Electrical Characteristics tables.
- (2) All voltages are with respect to the potential at the GND pin.
- (3) If Military/Aerospace specified devices are required, please contact the Texas Instruments Sales Office/ Distributors for availability and specifications.
- (4) Internal thermal shutdown circuitry protects the device from permanent damage. Thermal shutdown engages at  $T_J=140^\circ\text{C}$  (typ.) and disengages at  $T_J=120^\circ\text{C}$  (typ.).
- (5) For detailed soldering specifications and information, please refer to Texas Instruments Application Note: AN-1187 [SNOA401](#) for Recommended Soldering Profiles.
- (6) The human body model is a 100pF capacitor discharged through a 1.5k $\Omega$  resistor into each pin. (MIL-STD-883 3015.7)

## Operating Ratings <sup>(1)(2)</sup>

Input Voltage Range	2.7V to 5.5V
Junction Temperature (T <sub>J</sub> ) Range	-30°C to +125°C
Ambient Temperature (T <sub>A</sub> ) Range <sup>(3)</sup>	-30°C to +85°C

- (1) Absolute Maximum Ratings indicate limits beyond which damage to the component may occur. Operating Ratings are conditions under which operation of the device is specified. Operating Ratings do not imply performance limits. For performance limits and associated test conditions, see the Electrical Characteristics tables.
- (2) All voltages are with respect to the potential at the GND pin.
- (3) In applications where high power dissipation and/or poor package thermal resistance is present, the maximum ambient temperature may have to be derated. Maximum ambient temperature (T<sub>A-MAX</sub>) is dependent on the maximum operating junction temperature (T<sub>J-MAX-OP</sub> = 125°C), the maximum power dissipation of the device in the application (P<sub>D-MAX</sub>), and the junction-to-ambient thermal resistance of the part/package in the application (θ<sub>JA</sub>), as given by the following equation: T<sub>A-MAX</sub> = T<sub>J-MAX-OP</sub> – (θ<sub>JA</sub> × P<sub>D-MAX</sub>).

## Thermal Properties

Junction-to-Ambient Thermal Resistance (θ <sub>JA</sub> ), DQB0012A Package <sup>(1)</sup>	36.7°C/W
--	----------

- (1) Junction-to-ambient thermal resistance is highly application and board-layout dependent. In applications where high maximum power dissipation exists, special care must be paid to thermal dissipation issues in board design.

## Electrical Characteristics

Limits in standard typeface are for  $T_A = +25^\circ\text{C}$ . Limits in boldface type apply over the full operating junction temperature range ( $-30^\circ\text{C} \leq T_J \leq +125^\circ\text{C}$ ). Unless otherwise noted:  $V_{IN} = 3.6\text{V}$ ,  $R_{SET} = 16.5\text{k}\Omega$ ,  $V_{D1} = V_{D2} = 500\text{mV}$ , VFB bit = '0', FEN = '0', TX = '0', Flash Current Level = Full-Scale. <sup>(1)(2)(3)</sup>

Symbol	Parameter	Conditions	Min	Typ	Max	Units
$I_{LED-SUM}$	Flash LED Current: $I_{D1} + I_{D2}$	Flash Mode VDX = Regulation Voltage	<b>930</b>	1020	<b>1110</b>	mA
		Flash Mode VDX = Regulation Voltage RSET = 13.7k $\Omega$		1200		
$I_{LED-IND}$	Indicator Current Level	Indicator Mode		20		mA
$V_{MREG}$	Output Voltage Regulation in Voltage Mode	VM = '1', EN1 = EN0 = '0' No Load	<b>4.65</b>	4.98	<b>5.30</b>	V
$I_Q$	Quiescent Supply Current	$V_{D1,D2} = 0\text{V}$ (Switching)		1.0	<b>1.2</b>	mA
$I_{SD}$	Shutdown Supply Current	Device Disabled		3.8	<b>6.0</b>	$\mu\text{A}$
$I_{Dx} / I_{SET}$	LED Current to Set Current Ratio	$I_{Dx} = 500\text{mA}$		6770		A / A
$V_{SET}$	$I_{SET}$ Pin Voltage			1.24		V
$V_{D1,D2}$	Current Sink Regulation Voltage	VFB Bit = '0'		450		mV
		VFB Bit = '1'		350		
$I_{Dx-MATCH}$	Current Sink Matching	VDX = Regulation Voltage		2		%
$R_{DSON}$	NMOS Switch Resistance			0.25		$\Omega$
$I_{CL}$	NMOS Switch Current Limit	OCL Bit = '0'	<b>2.2</b>	2.5	<b>2.8</b>	A
		OCL Bit = '1'	<b>1.53</b>	1.70	<b>1.87</b>	
$I_{L-SW}$	SW Pin Leakage Current	Switch Off, $V_{SW} = 3.6\text{V}$ , OVP Mode = '0'		10		nA
$I_{L-Dx}$	D1, D2 Pin Leakage	$V_{Dx} = 3.5\text{V}$		10		nA
$V_{OVP}$	Output Over-Voltage Protection Trip Point	OVP Mode = '1'	<b>18.00</b>	18.90	<b>19.65</b>	V
		OVP Mode = '0'	<b>5.4</b>	5.6	<b>5.85</b>	
$OVP_{Hyst}$	Over-Voltage Protection Hysteresis OVP to Normal Operation	OVP Mode = '1'		1.6		V
		OVP Mode = '0'		0.6		
$I_{L-OVP}$	OVP Pin Leakage Current	$V_{OVP} = 3.6\text{V}$		10		nA
$f_{SW}$	Switching Frequency		<b>1.0</b>	1.2	<b>1.35</b>	MHz
$t_{FD-MIN}$	Minimum Flash Duration Step	$t_{FD-MIN} = 16 \div f_{SW}$		12.8		$\mu\text{sec.}$
$D_{MAX}$	Maximum Duty Cycle			92		%
$D_{MIN}$	Minimum Duty Cycle			6		%
$Th_{TX,F-EN}$	TX, FEN Pin Threshold	On	<b>1.0</b>		<b>VIN</b>	V
		Off	<b>0</b>		<b>0.6</b>	
<b>Multi-Function Pin (M/F) Voltage Specifications</b>						
$V_{M/F}$	Multi-Function Pin Threshold Voltages	Input Logic High "1"	<b>0.94</b>		<b>VIN</b>	V
		Input Logic Low "0"	<b>0</b>		<b>0.64</b>	
$V_{OL}$	Output Logic Low "0"	$I_{LOAD} = 4.2\text{mA}$ , GPIO Mode			<b>400</b>	mV
<b>I<sup>2</sup>C Compatible Voltage Specifications (SCL, SDIO, VIO)</b>						
VIO	Serial Bus Voltage Level		<b>1.45</b>		<b>VIN</b>	V
$V_{IL}$	Input Logic Low "0"	VIO = 3.0V	<b>0</b>		<b>0.38 x VIO</b>	V
$V_{IH}$	Input Logic High "1"	VIO = 3.0V	<b>0.55 x VIO</b>		<b>VIO</b>	V
$V_{OL}$	Output Logic Low "0"	$I_{LOAD} = 3.7\text{mA}$			<b>400</b>	mV

(1) All voltages are with respect to the potential at the GND pin.

(2) Min and Max limits are specified by design, test, or statistical analysis. Typical (Typ) numbers represent the most likely norm. Unless otherwise specified, conditions for Typ specifications are:  $V_{IN} = 3.6\text{V}$  and  $T_A = 25^\circ\text{C}$ .

(3) All testing for the LM3553 is done open-loop.

### Electrical Characteristics (continued)

Limits in standard typeface are for  $T_A = +25^\circ\text{C}$ . Limits in boldface type apply over the full operating junction temperature range ( $-30^\circ\text{C} \leq T_J \leq +125^\circ\text{C}$ ). Unless otherwise noted:  $V_{IN} = 3.6\text{V}$ ,  $R_{SET} = 16.5\text{k}\Omega$ ,  $V_{D1} = V_{D2} = 500\text{mV}$ , VFB bit = '0', FEN = '0', TX = '0', Flash Current Level = Full-Scale. <sup>(1)(2)(3)</sup>

Symbol	Parameter	Conditions	Min	Typ	Max	Units
<b>I<sup>2</sup>C Compatible Interface Timing Specifications (SCL, SDIO, VIO)</b>						
$t_1$	SCL (Clock Period)		<b>2.5</b>			$\mu\text{s}$
$t_2$	Data In Setup Time to SCL High		<b>100</b>			ns
$t_3$	Data Out stable After SCL Low		<b>0</b>			ns
$t_4$	SDA Low Setup Time to SCL Low (Start)		<b>100</b>			ns
$t_5$	SDA High Hold Time After SCL High (Stop)		<b>100</b>			ns

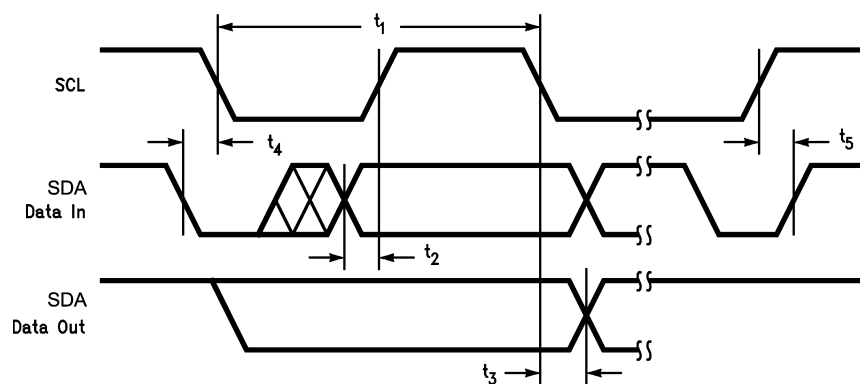

### Typical Performance Characteristics

Unless otherwise specified:  $T_A = 25^\circ\text{C}$ ;  $V_{IN} = 3.6\text{V}$ ;  $V_{M/F} = V_{IN}$ ;  $R_{SET} = 16.5\text{k}\Omega$ ;  $C_{IN} = 10\mu\text{F}$ ,  $C_{OUT} = 10\mu\text{F}$ ;  $L = 2.2\mu\text{H}$ ; VFB bit = CL bit = '0'; OVP bit = '0' for 1 LED and VFB = '1' for two series LEDs;.

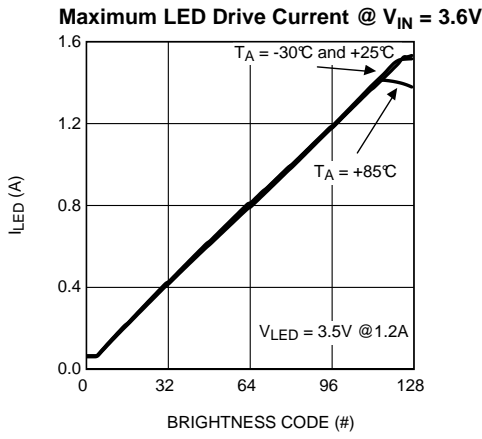

Figure 3.

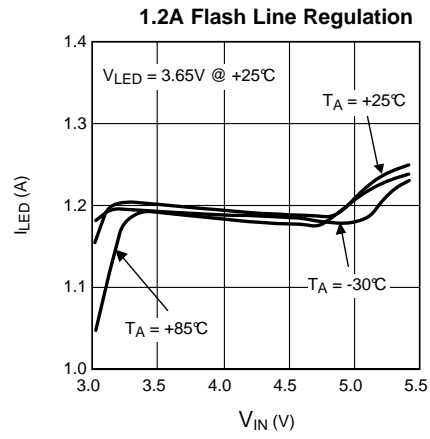

Figure 4.

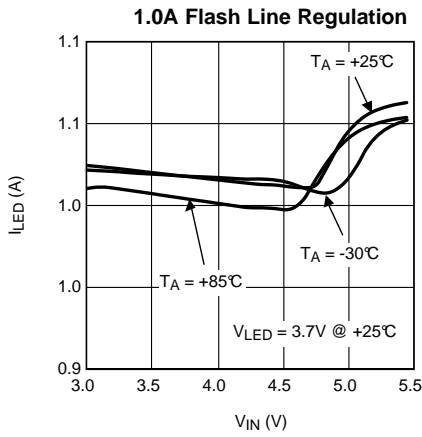

Figure 5.

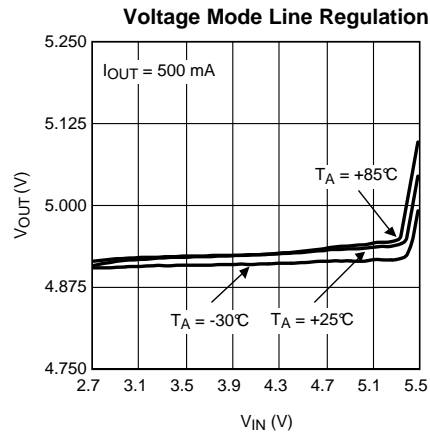

Figure 6.

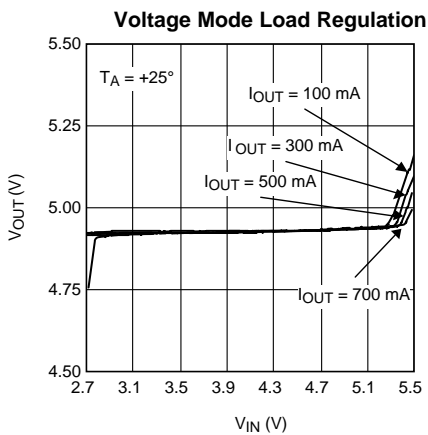

Figure 7.

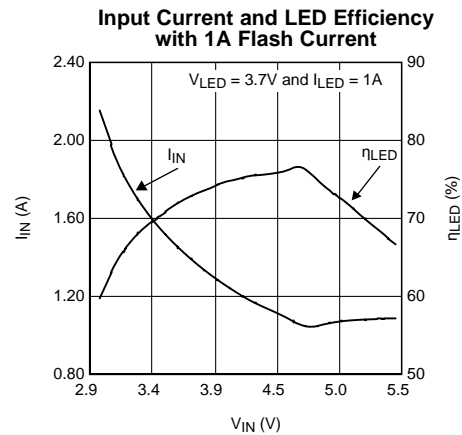

Figure 8.

### Typical Performance Characteristics (continued)

Unless otherwise specified:  $T_A = 25^\circ\text{C}$ ;  $V_{IN} = 3.6\text{V}$ ;  $V_{M/F} = V_{IN}$ ;  $R_{SET} = 16.5\text{k}\Omega$ ;  $C_{IN} = 10\mu\text{F}$ ;  $C_{OUT} = 10\mu\text{F}$ ;  $L = 2.2\mu\text{H}$ ; VFB bit = '0'; OVP bit = '0' for 1 LED and VFB = '1' for two series LEDs;

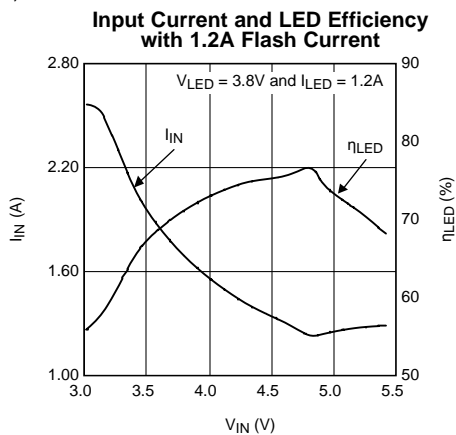

Figure 9.

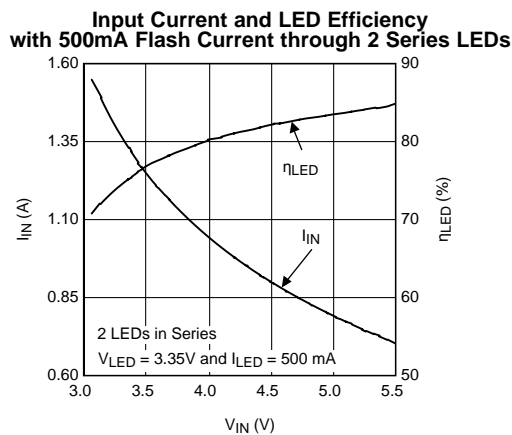

Figure 10.

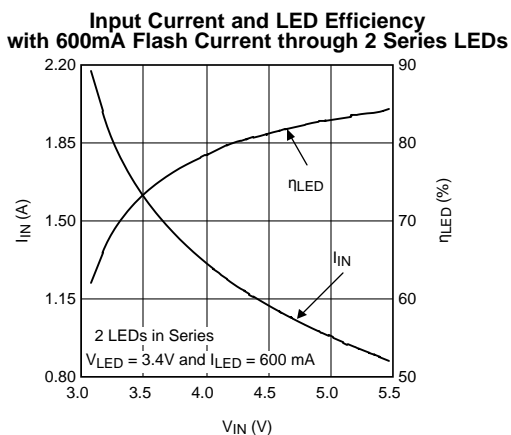

Figure 11.

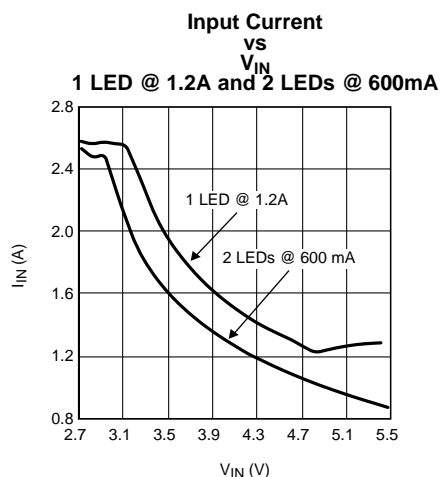

Figure 12.

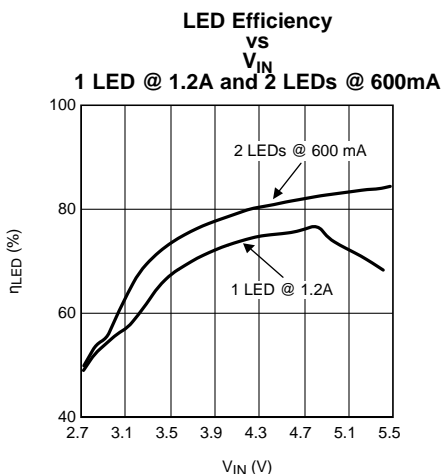

Figure 13.

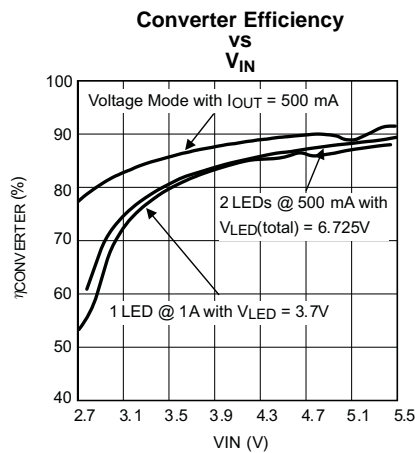
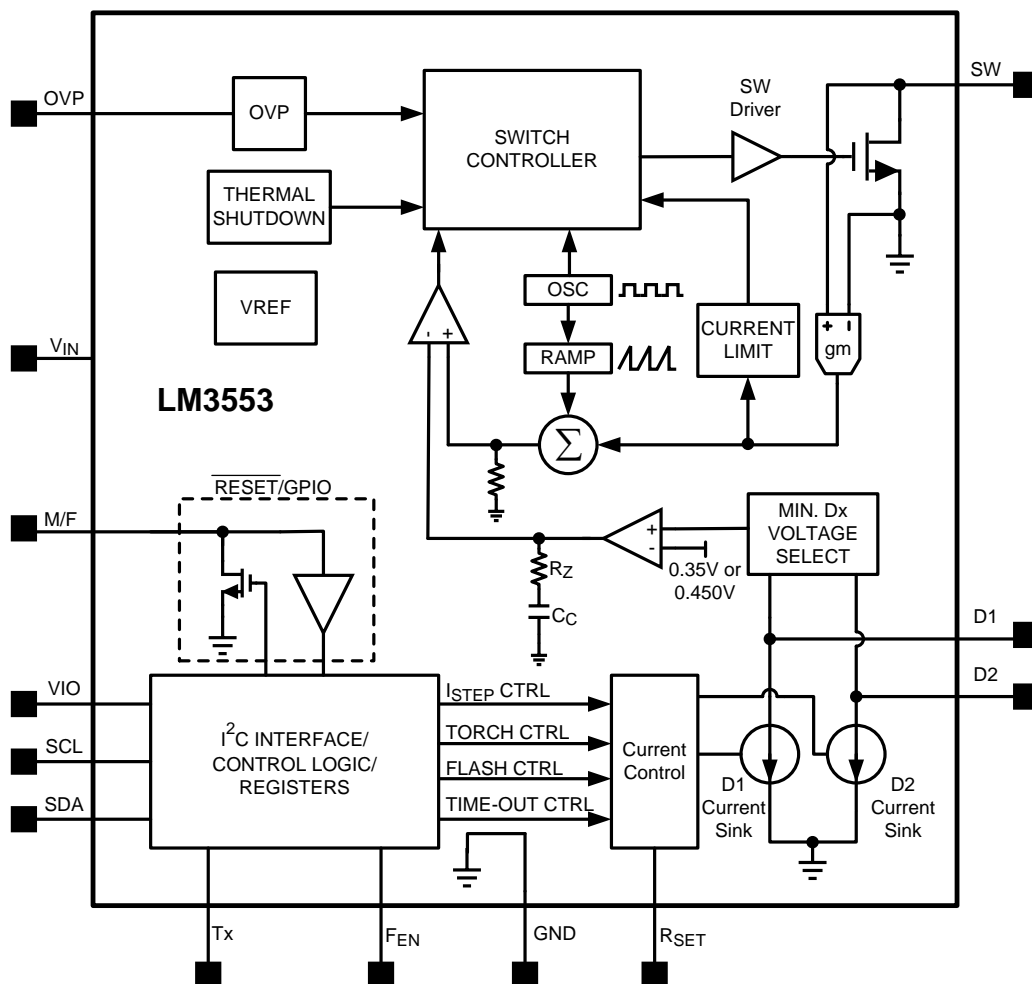

Figure 14.

## BLOCK DIAGRAM



## Circuit Description

### CIRCUIT COMPONENTS

#### *F<sub>EN</sub>* Pin

The flash enable pin,  $F_{EN}$ , provides an external method (non-I<sup>2</sup>C) for starting the flash pulse. When  $F_{EN}$  is pulled high, logic '1', the flash current level defined through the I<sup>2</sup>C interface, will be delivered to the Flash LED. If the  $F_{EN}$  pin is driven low during the flash pulse, the flash event will stop. In the event that  $F_{EN}$  is not pulled low during the flash pulse, the LM3553 will continue to deliver the flash current until the safety timer duration (set through the I<sup>2</sup>C interface) is reached.

The LM3553 does not provide a fixed off-time after the flash pulse has ended. Most flash LED manufacturers require that the flash pulse duration be 10% of the total Flash cycle. Example: If the flash pulse duration is set to be 200 milliseconds (Flash Duration Code= 0011), the recommended off time for the LED would be 1.8 seconds. Please consult the LED manufacturers datasheet for exact timing requirements.

If the LM3553 is placed in indicator mode or torch mode through the I<sup>2</sup>C interface and the  $F_{EN}$  pin is pulled high and then low, at the end of the flash event, the LM3553 will return to the mode stored in the General Purpose Register.

It is recommended that an external pull-down be placed between the  $F_{EN}$  pin and GND to prevent unwanted LED flashing during system start-up due to unknown control logic states.

### *T<sub>X</sub> Pin*

The transmission pin ( $T_X$ ) can be used to limit the current drawn from the battery during a PA transmission. When the  $T_X$  pin is driven high (logic '1') during a flash pulse, the LM3553 will switch to the programmed torch current level. Once the  $T_X$  pin is driven low (logic '0'), the LM3553 will return to the flash current if this event occurs within the original flash duration.

It is recommended that an external pull-down be placed between the  $T_X$  pin and GND to prevent unwanted LED flashing during system start-up due to unknown control logic states.

### *M/F Pin*

The multi-function pin (M/F) can be configured to provide hardware RESET or a general purpose input/output (GPIO). All functionality is programmed through the I<sup>2</sup>C compatible interface and set in the M/F pin functionality control register (address 0x20). The default function is a  $\overline{\text{RESET}}$ , where a logic '1' places the part in the normal operating mode, and a logic '0' places the part into a RESET state. A reset condition will place all LM3553 registers into their default states.

### *Connection Diagram*

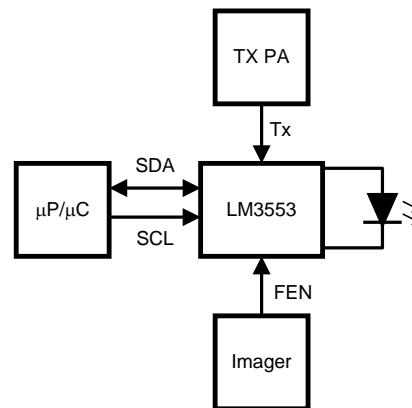

Figure 15. Typical System Configuration

### *I<sup>2</sup>C Compatible Interface*

#### DATA VALIDITY

The data on SDA line must be stable during the HIGH period of the clock signal (SCL). In other words, the state of the data line can only be changed when CLK is LOW.

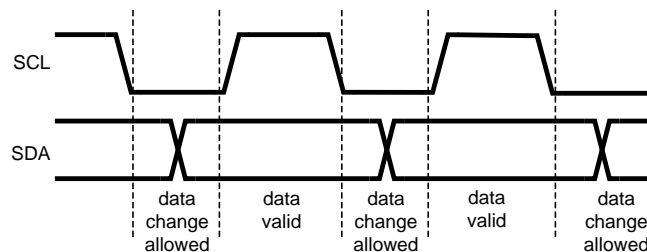
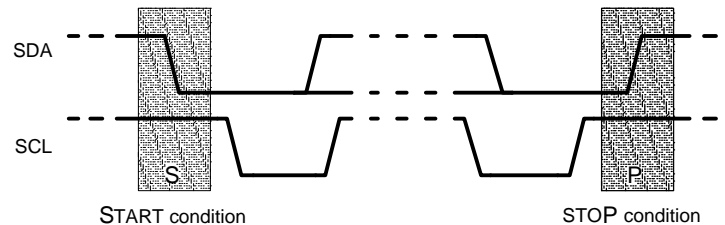

Figure 16. Data Validity Diagram

A pull-up resistor between VIO and SDA must be greater than  $[(V_{IO} - V_{OL}) / 3.7\text{mA}]$  to meet the  $V_{OL}$  requirement on SDA. Using a larger pull-up resistor results in lower switching current with slower edges, while using a smaller pull-up results in higher switching currents with faster edges.

## START AND STOP CONDITIONS

START and STOP conditions classify the beginning and the end of the I<sup>2</sup>C session. A START condition is defined as SDA signal transitioning from HIGH to LOW while SCL line is HIGH. A STOP condition is defined as the SDA transitioning from LOW to HIGH while SCL is HIGH. The I<sup>2</sup>C master always generates START and STOP conditions. The I<sup>2</sup>C bus is considered to be busy after a START condition and free after a STOP condition. During data transmission, the I<sup>2</sup>C master can generate repeated START conditions. First START and repeated START conditions are equivalent, function-wise. The data on SDA line must be stable during the HIGH period of the clock signal (SCL). In other words, the state of the data line can only be changed when CLK is LOW.

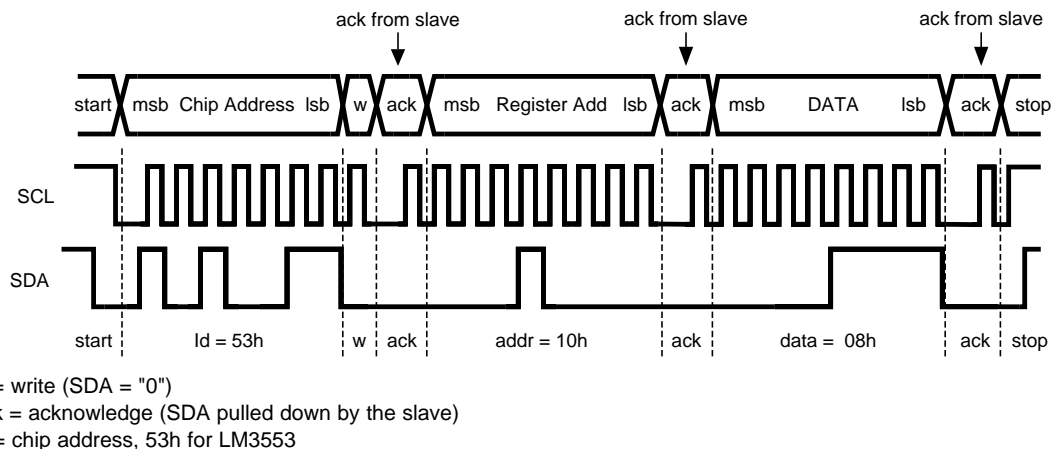

**Figure 17. Start and Stop Conditions**

## TRANSFERRING DATA

Every byte put on the SDA line must be eight bits long, with the most significant bit (MSB) being transferred first. Each byte of data has to be followed by an acknowledge bit. The acknowledge related clock pulse is generated by the master. The master releases the SDA line (HIGH) during the acknowledge clock pulse. The LM3553 pulls down the SDA line during the 9th clock pulse, signifying an acknowledge. The LM3553 generates an acknowledge after each byte has been received.

After the START condition, the I<sup>2</sup>C master sends a chip address. This address is seven bits long followed by an eighth bit which is a data direction bit (R/W). The LM3553 address is 53h. For the eighth bit, a "0" indicates a WRITE and a "1" indicates a READ. The second byte selects the register to which the data will be written. The third byte contains data to write to the selected register.



**Figure 18. Write Cycle**

## I<sup>2</sup>C COMPATIBLE CHIP ADDRESS

The chip address for LM3553 is 1010011, or 53hex.

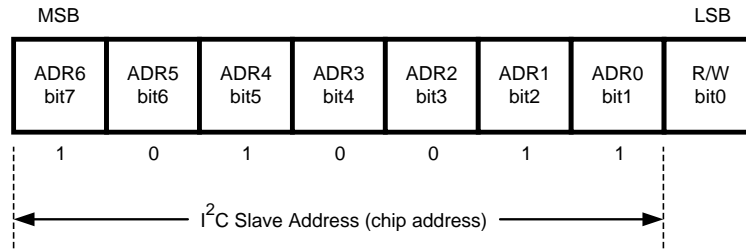

**INTERNAL REGISTERS OF LM3553**

Register	Internal Hex Address	Power On Value
General Purpose Register	0x10	0001 1000
Multi-Function Pin Control Register	0x20	1110 0000
Current Step Time Register	0x50	1111 1100
Torch Current Control Register	0xA0	1000 0000
Flash Current Control Register	0xB0	1000 0000
Flash Duration Control Register	0xC0	1111 0000

**General Purpose Register**

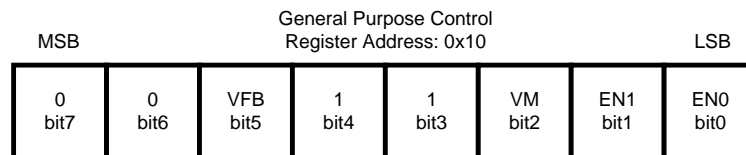

**EN0-EN1: Set Flash LED mode**

Indicator Mode sets I<sub>LED</sub> = 20mA. In this mode, D1 is enabled and D2 is disabled.

**VM:** Enables Voltage Mode. Current sinks D1 and D2 are turned off and the LM3553 will operate in a regulated voltage boost mode. Setting the VM bit to a '1' does not override the EN0 and EN1 bits stored in the general purpose register. The default setting is '0'. If the LM3553 is in Voltage Mode and an indicator, torch or flash command is issued, the LM3553 will turn on the D1 and D2 current sources and begin regulating the output voltage to a value equal to VFB (350mV or 450mV) + VLED.

VM	EN1	EN0	Function
0	0	0	Shutdown
0	0	1	Indicator Mode
0	1	0	Torch Mode
0	1	1	Flash Mode
1	0	0	Voltage Mode
1	0	1	Indicator Mode
1	1	0	Torch Mode
1	1	1	Flash Mode

**VFB:** Selects the regulation voltage for the LM3553. Setting this VFB bit to a '0' sets the regulation voltage to 450mV while setting the VFB bit to a '1' sets the regulation voltage to 350mV. Setting the VFB bit to a '1' during torch mode and/or lower current flash modes ( $I_{LED} < 1A$ ) will help improve the LED efficiency of the LM3553.

### M/F Pin Control Register

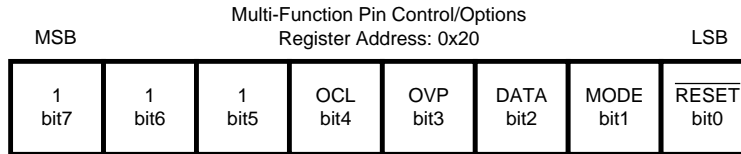

**$\overline{\text{RESET}}$ :** Enables M/F as hardware RESET. '0' = Hardware RESET, '1' = GPIO or current sink depending on the MODE bit. Default = '0'

**MODE:** Sets M/F mode. Default for MODE = '0'. '0' = GPI, and '1' = GPO

### NOTE

When M/F is configured as an input, data is transferred from GPI to DATA whenever an I<sup>2</sup>C write command is issued to the LM3553. When configuring M/F as a GPO, the first write needs to take the LM3553 out of RESET mode and a second write can then set the pin to the GPO.

**DATA:** GPIO Data. When the M/F is configured as an output (GPO), DATA sets the GPO level. Example: DATA = '1', M/F is set high or logic '1'. When the M/F pin is configured as an input (GPI), DATA stores the GPI level. Example: M/F = '1', DATA will be set to a '1'. Default for DATA = '0'.

**OVP:** Enables high-voltage OVP (OVP Bit = '1') or low-voltage OVP (OVP Bit = '0'). Default = low-voltage mode '0'

**OCL:** SW Pin Current Limit Selector Bit: If OCL = '0', the inductor current limit is 2.5A typ. If OCL = '1', the inductor current limit is 1.7A typ.

**Table 1. M/F Functionality Configuration Table**

$\overline{\text{RESET}}$	MODE	M/F Function
0	X	$\overline{\text{RESET}}$
1	0	GPI
1	1	GPO

### Current Step Time Register

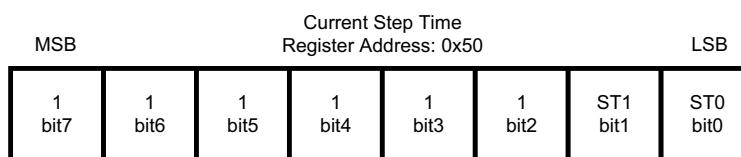

**ST1-ST0:** Sets current level stepping time for D1 and D2 during the beginning and end of the flash or torch current waveform. '00' = 25 $\mu$ s, '01' = 50 $\mu$ s, '10' = 100 $\mu$ s, '11' = 200 $\mu$ s.

The current ramp-up/ramp-down times can be approximated by the following equation:

$$T_{\text{RAMPUP/RAMPDOWN}} = (N_{\text{FLASH}} - N_{\text{START}} + 1) \times t_{\text{STEP}}$$

where

- N is equal to the decimal value of the brightness level
- ( $0 \leq N_{\text{FLASH}} \leq 127$  and  $0 \leq N_{\text{START}} \leq 31$ )

$N_{\text{START}} = N_{\text{TORCH}}$  if Torch is enabled before going into a flash. If going straight into a flash from an off-state,  $N_{\text{START}} = 0$ .

**Torch Current Control Register**

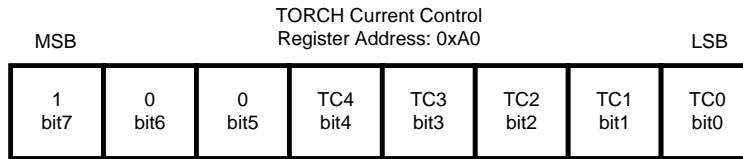

**TC6-TC0:** Sets Torch current level for D1 and D2. xxx1 1111 = Fullscale

**Flash Current Control Register**

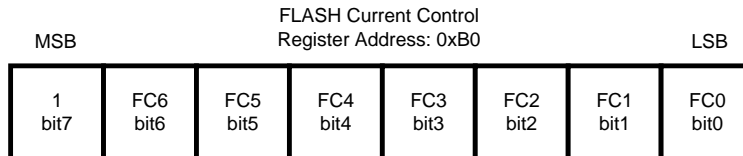

**FC6-FC0:** Sets Flash current level for D1 and D2. x111 1111 = Fullscale

**Current Level Equation**

The Full-Scale Flash Current Level is set through the use of an external resistor ( $R_{SET}$ ) connected to the  $I_{SET}$  pin. The  $R_{SET}$  selection equation can be used to set the current through each of the two current sinks, D1 and D2.

$$R_{SET} = 6770 \times 1.24V \div I_{Dx}$$

**Table 2.  $R_{SET}$  Selection Table**

$I_{Flash} = ID1 + ID2$	$R_{SET}$
500mA	33.6k $\Omega$
600mA	28k $\Omega$
1A	16.8k $\Omega$
1.2A	14k $\Omega$

The current through each current sink, D1 and D2, can be approximated by the following equation using the values stored in either the Torch or Flash Current Control registers.

$$I_{FLASH} \approx (N + 1) \times I_{LED\_TOTAL} \div 128$$

where N is the decimal equivalent number ( $0 \leq N \leq 127$  for Flash and  $0 \leq N \leq 31$  for Torch) stored in the Torch or Flash Current control registers and  $I_{LED\_TOTAL} = I_{D1} + I_{D2}$  @ Full-scale. Brightness codes 0 through 4 are repeated and each sets the total LED current to approximately 40mA.

**Flash Safety Timer Control Register**

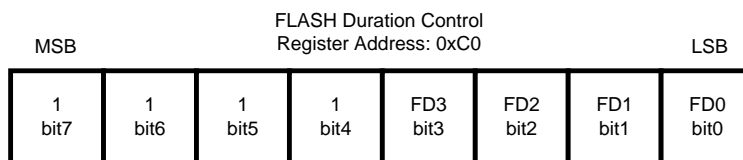

**FD3-FD0:** Sets Flash Duration for D1 and D2. 1111 = Fullscale

Safety Timer Duration Code (Binary)	Typical Safety Timer Duration (milliseconds)
0000	50
0001	100
0010	200
0011	300
0100	400
0101	500

Safety Timer Duration Code (Binary)	Typical Safety Timer Duration (milliseconds)
0110	600
0111	700
1000	800
1001	900
1010	1000
1011	1100
1100	1200
1101	1300
1110	1400
1111	3200

**Table 3. LM3553 Functionality Truth Table**

EN1	EN0	F <sub>EN</sub>	T <sub>x</sub>	Result
0	0	0	0	Shutdown
0	0	0	1	Shutdown
0	0	1	0	Flash
0	0	1	1	Torch
0	1	0	0	Indicator
0	1	0	1	Indicator
0	1	1	0	Flash
0	1	1	1	Torch
1	0	0	0	Torch
1	0	0	1	Torch
1	0	1	0	Flash
1	0	1	1	Torch
1	1	0	0	Flash
1	1	0	1	Torch
1	1	1	0	Flash
1	1	1	1	Torch

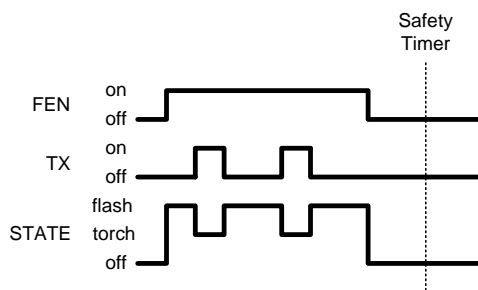

**Figure 19. FEN Terminated Pulse**

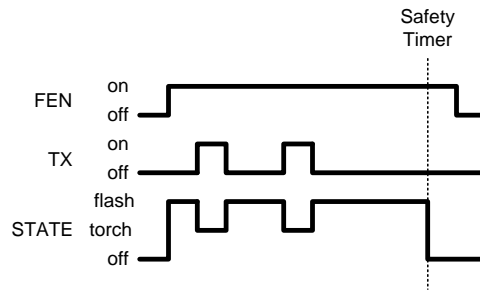

Figure 20. Safety Timer Terminated Pulse

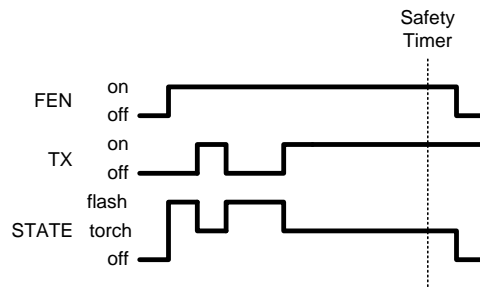

Figure 21. TX Terminated Pulse

## Application Information

### INDUCTOR SELECTION

The LM3553 is designed to use a 2.2µH inductor. When the device is boosting ( $V_{OUT} > V_{IN}$ ) the inductor is one of the biggest sources of efficiency loss in the circuit. Therefore, choosing an inductor with the lowest possible series resistance is important. Additionally, the saturation rating of the inductor should be greater than the maximum operating peak current of the LM3553. This prevents excess efficiency loss that can occur with inductors that operate in saturation and prevents over heating of the inductor and possible damage. For proper inductor operation and circuit performance ensure that the inductor saturation and the peak current limit setting of the LM3553 (2.6A or 1.8A) is greater than  $I_{PEAK}$ .  $I_{PEAK}$  can be calculated by:

$$I_{PEAK} = \frac{I_{LOAD}}{\eta} \times \frac{V_{OUT}}{V_{IN}} + \Delta I_L$$

where

$$\Delta I_L = \frac{V_{IN} \times (V_{OUT} - V_{IN})}{2 \times f_{SW} \times L \times V_{OUT}}$$

(1)

Table 4. Recommended Inductors

Manufacturer	Part#	L / I <sub>SAT</sub>
Toko	FDSE312-2R2M	2.2µH / 2.3A
Coilcraft	LPS4012-222ML	2.2µH / 2.3A
TDK	VLF4014ST-2R2M1R9	2.2µH / 2.0A

## CAPACITOR SELECTION

The LM3553 requires 2 external capacitors for proper operation ( $C_{IN} = 10\mu\text{F}$  recommended (4.7 $\mu\text{F}$  min.) and  $C_{OUT} = 10\mu\text{F}$  (single LED) or 4.7 $\mu\text{F}$  (series LEDs)). Surface-mount multi-layer ceramic capacitors are recommended. These capacitors are small, inexpensive and have very low equivalent series resistance (ESR <20m $\Omega$  typ.). Tantalum capacitors, OS-CON capacitors, and aluminum electrolytic capacitors are not recommended for use with the LM3553 due to their high ESR, as compared to ceramic capacitors.

For most applications, ceramic capacitors with X7R or X5R temperature characteristic are preferred for use with the LM3553. These capacitors have tight capacitance tolerance (as good as  $\pm 10\%$ ) and hold their value over temperature (X7R:  $\pm 15\%$  over -55°C to 125°C; X5R:  $\pm 15\%$  over -55°C to 85°C).

Capacitors with Y5V or Z5U temperature characteristic are generally not recommended for use with the LM3553. Capacitors with these temperature characteristics typically have wide capacitance tolerance (+80%, -20%) and vary significantly over temperature (Y5V: +22%, -82% over -30°C to +85°C range; Z5U: +22%, -56% over +10°C to +85°C range). Under some conditions, a nominal 1 $\mu\text{F}$  Y5V or Z5U capacitor could have a capacitance of only 0.1 $\mu\text{F}$ . Such detrimental deviation is likely to cause Y5V and Z5U capacitors to fail to meet the minimum capacitance requirements of the LM3553.

**The recommended voltage rating for the input capacitor is 10V (min = 6.3V). For a single flash LED, the recommended output capacitor voltage rating is 10V (min = 6.3V), and for series LEDs the recommended voltage is 25V (min = closest voltage rating above the sum of ( $V_{LED} \times N_{LEDs}$ ) and  $V_{FB}$ ). The recommended value takes into account the DC bias capacitance losses, while the minimum rating takes into account the OVP trip levels.**

## SCHOTTKY DIODE SELECTION

The output diode must have a reverse breakdown voltage greater than the maximum output voltage. The diodes average current rating should be high enough to handle the LM3553's output current. Additionally, the diodes peak current rating must be high enough to handle the peak inductor current. Schottky diodes are recommended due to their lower forward voltage drop (0.3V to 0.5V) compared to (0.8V) for PN junction diodes.

## LAYOUT CONSIDERATIONS

The WSON is a leadless package with very good thermal properties. This package has an exposed DAP (die attach pad) at the underside center of the package measuring 1.86mm x 2.2mm. The main advantage of this exposed DAP is to offer low thermal resistance when soldered to the thermal ground pad on the PCB. For good PCB layout a 1:1 ratio between the package and the PCB thermal land is recommended. To further enhance thermal conductivity, the PCB thermal ground pad may include vias to a 2nd layer ground plane. For more detailed instructions on mounting WSON packages, please refer to Texas Instruments Application Note AN-1187 [SNOA401](#).

The high switching frequencies and large peak currents make the PCB layout a critical part of the design. The proceeding steps must be followed to ensure stable operation and proper current source regulation.

1. If possible, divide ground into two planes, one for the return terminals of  $C_{OUT}$ ,  $C_{IN}$  and the I<sup>2</sup>C Bus, the other for the return terminals of  $R_{SET}$ . Connect both planes to the exposed DAP, but nowhere else.
2. Connect the inductor and the anode of D1(schottky) as close together as possible and place this connection as close as possible to the SW pin. This reduces the inductance and resistance of the switching node which minimizes ringing and excess voltage drops.
3. Connect the return terminals of the input capacitor and the output capacitor as close as possible to the exposed DAP and through low impedance traces.
4. Bypass  $V_{IN}$  with at least a 4.7 $\mu\text{F}$  ceramic capacitor. Connect the positive terminal of this capacitor as close as possible to  $V_{IN}$ .
5. Connect  $C_{OUT}$  as close as possible to the cathode of D1(schottky). This reduces the inductance and resistance of the output bypass node which minimizes ringing and voltage drops. This will improve efficiency and decrease the noise injected into the current sources.
6. Route the trace for  $R_{SET}$  away from the SW node to minimize noise injection.
7. Do not connect any external capacitor to the  $R_{SET}$  pin.

## THERMAL PROTECTION

Internal thermal protection circuitry disables the LM3553 when the junction temperature exceeds 150°C (typ.). This feature protects the device from being damaged by high die temperatures that might otherwise result from excessive power dissipation. The device will recover and operate normally when the junction temperature falls below 140°C (typ.). It is important that the board layout provide good thermal conduction to keep the junction temperature within the specified operating ratings.

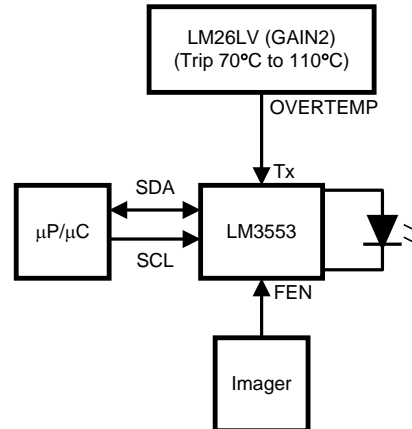

**Figure 22. External Temperature Sensor Diagram**

Using an external temperature sensor, such as the LM26LV, can help aid in the thermal protection of the flash LEDs as well as other components in a design. Connecting the OVERTEMP pin of the LM26LV to the TX pin on the LM3553 prevents the high current flash from turning on when the set temperature threshold on the LM26LV is reached. When the temperature trip point is reached, the OVERTEMP pin on the LM26LV will transition from a '0' to a '1' which in turn enables the LM3553's TX mode. When a flash is instantiated by either the imager or microprocessor, the LM3553 will only allow the flash LED current to reach the current level set in the Torch Current register as long as the temperature sensor is registering an over-temperature condition. Placing the temperature sensor close to the flash LEDs can help prevent the LEDs from reaching a temperature above the maximum specified limit due to high-current flashing in a high temperature ambient environment.

## LM3553 CONFIGURATIONS

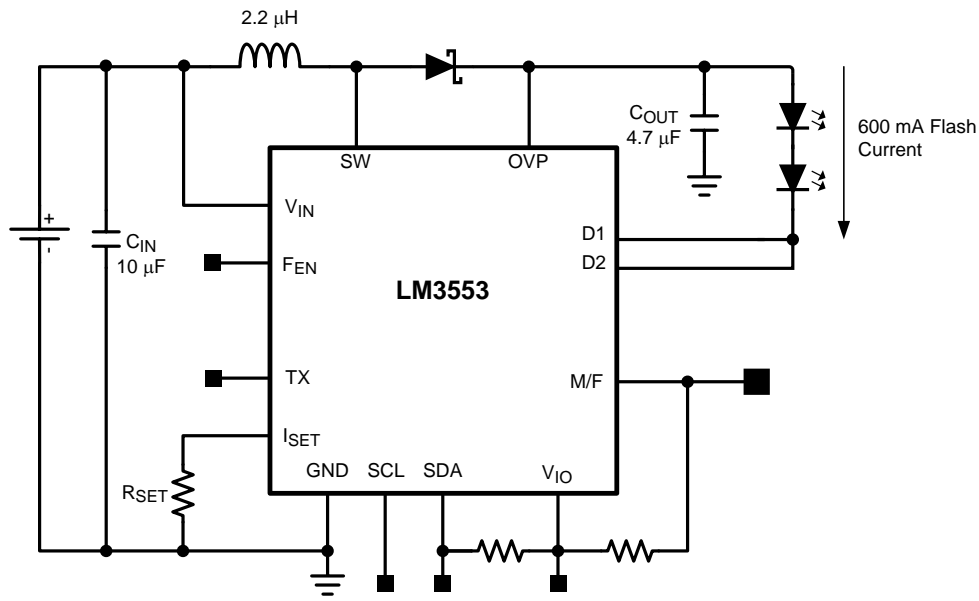

Components:  
 L = Toko FDSE0312-2R2M  
 $C_{IN}$  = Murata GRM188R60J106ME47D  
 $C_{OUT}$  = Murata GRM21BR61E475KA12L  
 LEDs = Lumileds LXCL – PWF3  
 Or equivalent

**Figure 23. 2 LEDs @ 600mA with Battery Input**

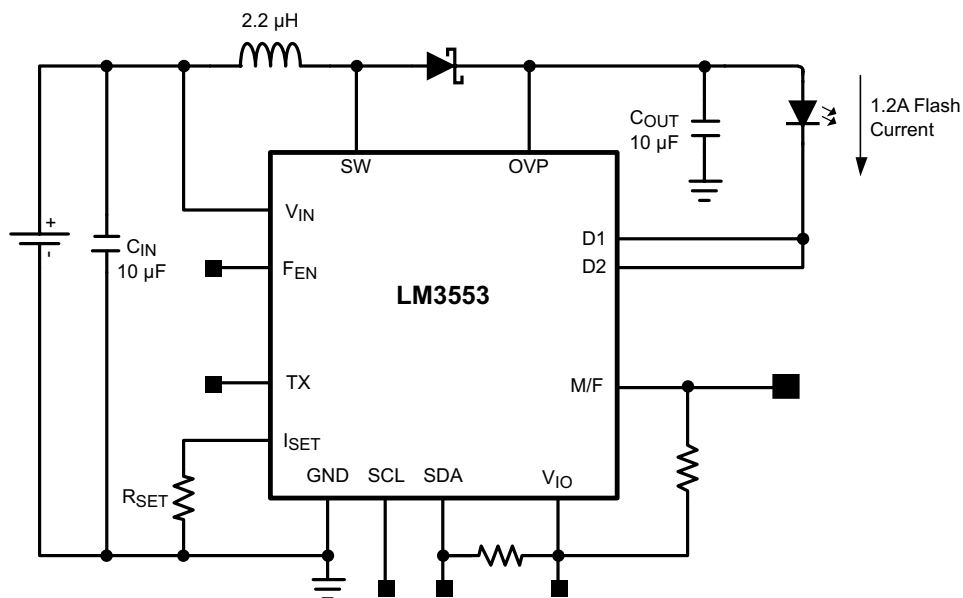

**Figure 24. 1 LED @ 1.2A with Battery Input**

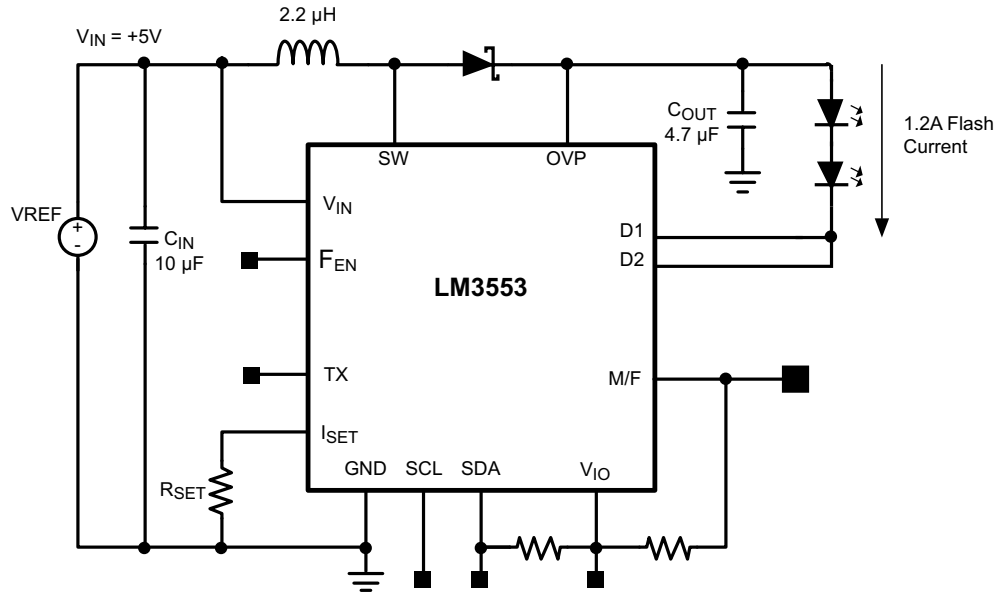

Figure 25. 2 LEDs @ 1.2A with +5V Input

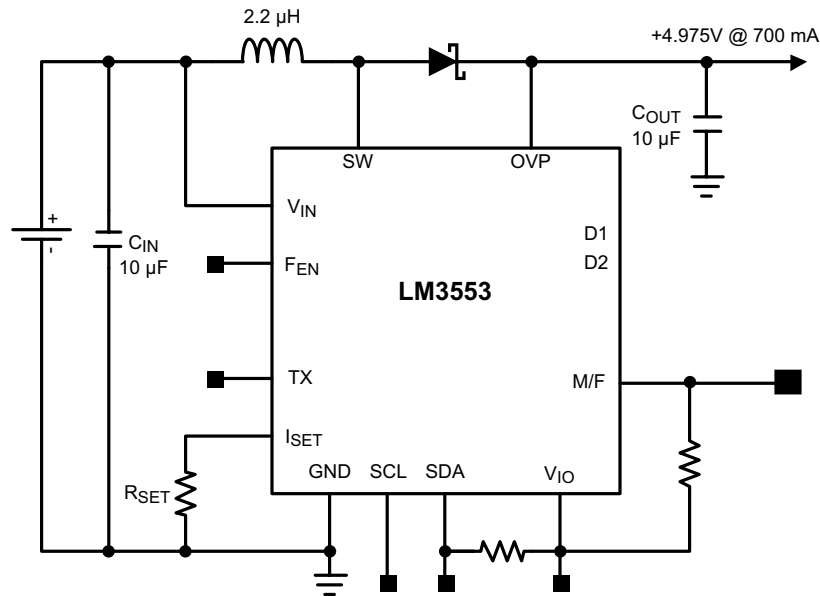

Figure 26. Voltage Mode @ 700mA with Battery Input

## REVISION HISTORY

Changes from Revision A (May 2013) to Revision B	Page
• Changed layout of National Data Sheet to TI format .....	<a href="#">19</a>

**PACKAGING INFORMATION**

Orderable Device	Status (1)	Package Type	Package Drawing	Pins	Package Qty	Eco Plan (2)	Lead/Ball Finish (6)	MSL Peak Temp (3)	Op Temp (°C)	Device Marking (4/5)	Samples
LM3553SD/NOPB	ACTIVE	WSON	DQB	12	1000	Green (RoHS & no Sb/Br)	CU SN	Level-3-260C-168 HR	-30 to 85	L3553	<a href="#">Samples</a>
LM3553SDX/NOPB	ACTIVE	WSON	DQB	12	4500	Green (RoHS & no Sb/Br)	CU SN	Level-3-260C-168 HR	-30 to 85	L3553	<a href="#">Samples</a>

(1) The marketing status values are defined as follows:

**ACTIVE:** Product device recommended for new designs.

**LIFEBUY:** TI has announced that the device will be discontinued, and a lifetime-buy period is in effect.

**NRND:** Not recommended for new designs. Device is in production to support existing customers, but TI does not recommend using this part in a new design.

**PREVIEW:** Device has been announced but is not in production. Samples may or may not be available.

**OBSOLETE:** TI has discontinued the production of the device.

(2) Eco Plan - The planned eco-friendly classification: Pb-Free (RoHS), Pb-Free (RoHS Exempt), or Green (RoHS & no Sb/Br) - please check <http://www.ti.com/productcontent> for the latest availability information and additional product content details.

**TBD:** The Pb-Free/Green conversion plan has not been defined.

**Pb-Free (RoHS):** TI's terms "Lead-Free" or "Pb-Free" mean semiconductor products that are compatible with the current RoHS requirements for all 6 substances, including the requirement that lead not exceed 0.1% by weight in homogeneous materials. Where designed to be soldered at high temperatures, TI Pb-Free products are suitable for use in specified lead-free processes.

**Pb-Free (RoHS Exempt):** This component has a RoHS exemption for either 1) lead-based flip-chip solder bumps used between the die and package, or 2) lead-based die adhesive used between the die and leadframe. The component is otherwise considered Pb-Free (RoHS compatible) as defined above.

**Green (RoHS & no Sb/Br):** TI defines "Green" to mean Pb-Free (RoHS compatible), and free of Bromine (Br) and Antimony (Sb) based flame retardants (Br or Sb do not exceed 0.1% by weight in homogeneous material)

(3) MSL, Peak Temp. - The Moisture Sensitivity Level rating according to the JEDEC industry standard classifications, and peak solder temperature.

(4) There may be additional marking, which relates to the logo, the lot trace code information, or the environmental category on the device.

(5) Multiple Device Markings will be inside parentheses. Only one Device Marking contained in parentheses and separated by a "~" will appear on a device. If a line is indented then it is a continuation of the previous line and the two combined represent the entire Device Marking for that device.

(6) Lead/Ball Finish - Orderable Devices may have multiple material finish options. Finish options are separated by a vertical ruled line. Lead/Ball Finish values may wrap to two lines if the finish value exceeds the maximum column width.

**Important Information and Disclaimer:** The information provided on this page represents TI's knowledge and belief as of the date that it is provided. TI bases its knowledge and belief on information provided by third parties, and makes no representation or warranty as to the accuracy of such information. Efforts are underway to better integrate information from third parties. TI has taken and continues to take reasonable steps to provide representative and accurate information but may not have conducted destructive testing or chemical analysis on incoming materials and chemicals. TI and TI suppliers consider certain information to be proprietary, and thus CAS numbers and other limited information may not be available for release.

In no event shall TI's liability arising out of such information exceed the total purchase price of the TI part(s) at issue in this document sold by TI to Customer on an annual basis.

## TAPE AND REEL INFORMATION



### QUADRANT ASSIGNMENTS FOR PIN 1 ORIENTATION IN TAPE



\*All dimensions are nominal

Device	Package Type	Package Drawing	Pins	SPQ	Reel Diameter (mm)	Reel Width W1 (mm)	A0 (mm)	B0 (mm)	K0 (mm)	P1 (mm)	W (mm)	Pin1 Quadrant
LM3553SD/NOPB	WSON	DQB	12	1000	178.0	12.4	3.3	3.3	1.0	8.0	12.0	Q1
LM3553SDX/NOPB	WSON	DQB	12	4500	330.0	12.4	3.3	3.3	1.0	8.0	12.0	Q1

**TAPE AND REEL BOX DIMENSIONS**



\*All dimensions are nominal

Device	Package Type	Package Drawing	Pins	SPQ	Length (mm)	Width (mm)	Height (mm)
LM3553SD/NOPB	WSON	DQB	12	1000	213.0	191.0	55.0
LM3553SDX/NOPB	WSON	DQB	12	4500	367.0	367.0	35.0

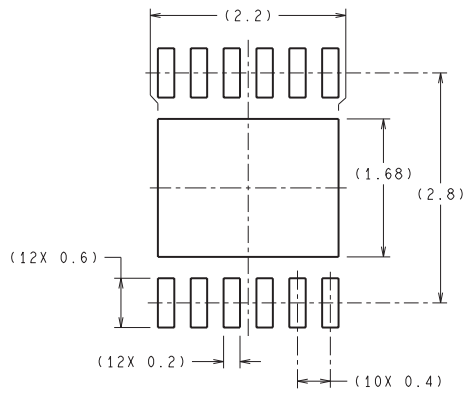
DQB0012A

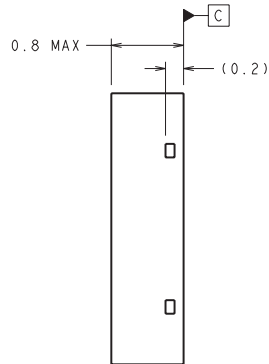
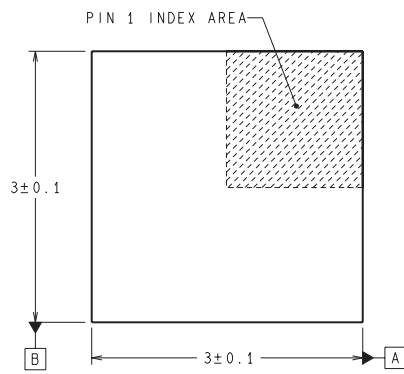

RECOMMENDED LAND PATTERN



DIMENSIONS ARE IN MILLIMETERS  
DIMENSIONS IN ( ) FOR REFERENCE ONLY

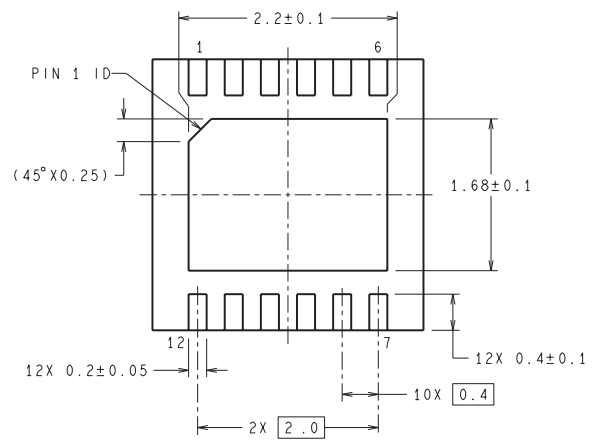
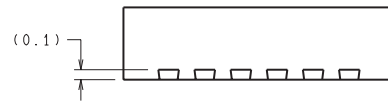

SDF12A (Rev B)

## IMPORTANT NOTICE

Texas Instruments Incorporated and its subsidiaries (TI) reserve the right to make corrections, enhancements, improvements and other changes to its semiconductor products and services per JESD46, latest issue, and to discontinue any product or service per JESD48, latest issue. Buyers should obtain the latest relevant information before placing orders and should verify that such information is current and complete. All semiconductor products (also referred to herein as "components") are sold subject to TI's terms and conditions of sale supplied at the time of order acknowledgment.

TI warrants performance of its components to the specifications applicable at the time of sale, in accordance with the warranty in TI's terms and conditions of sale of semiconductor products. Testing and other quality control techniques are used to the extent TI deems necessary to support this warranty. Except where mandated by applicable law, testing of all parameters of each component is not necessarily performed.

TI assumes no liability for applications assistance or the design of Buyers' products. Buyers are responsible for their products and applications using TI components. To minimize the risks associated with Buyers' products and applications, Buyers should provide adequate design and operating safeguards.

TI does not warrant or represent that any license, either express or implied, is granted under any patent right, copyright, mask work right, or other intellectual property right relating to any combination, machine, or process in which TI components or services are used. Information published by TI regarding third-party products or services does not constitute a license to use such products or services or a warranty or endorsement thereof. Use of such information may require a license from a third party under the patents or other intellectual property of the third party, or a license from TI under the patents or other intellectual property of TI.

Reproduction of significant portions of TI information in TI data books or data sheets is permissible only if reproduction is without alteration and is accompanied by all associated warranties, conditions, limitations, and notices. TI is not responsible or liable for such altered documentation. Information of third parties may be subject to additional restrictions.

Resale of TI components or services with statements different from or beyond the parameters stated by TI for that component or service voids all express and any implied warranties for the associated TI component or service and is an unfair and deceptive business practice. TI is not responsible or liable for any such statements.

Buyer acknowledges and agrees that it is solely responsible for compliance with all legal, regulatory and safety-related requirements concerning its products, and any use of TI components in its applications, notwithstanding any applications-related information or support that may be provided by TI. Buyer represents and agrees that it has all the necessary expertise to create and implement safeguards which anticipate dangerous consequences of failures, monitor failures and their consequences, lessen the likelihood of failures that might cause harm and take appropriate remedial actions. Buyer will fully indemnify TI and its representatives against any damages arising out of the use of any TI components in safety-critical applications.

In some cases, TI components may be promoted specifically to facilitate safety-related applications. With such components, TI's goal is to help enable customers to design and create their own end-product solutions that meet applicable functional safety standards and requirements. Nonetheless, such components are subject to these terms.

No TI components are authorized for use in FDA Class III (or similar life-critical medical equipment) unless authorized officers of the parties have executed a special agreement specifically governing such use.

Only those TI components which TI has specifically designated as military grade or "enhanced plastic" are designed and intended for use in military/aerospace applications or environments. Buyer acknowledges and agrees that any military or aerospace use of TI components which have *not* been so designated is solely at the Buyer's risk, and that Buyer is solely responsible for compliance with all legal and regulatory requirements in connection with such use.

TI has specifically designated certain components as meeting ISO/TS16949 requirements, mainly for automotive use. In any case of use of non-designated products, TI will not be responsible for any failure to meet ISO/TS16949.

### Products

Audio	<a href="http://www.ti.com/audio">www.ti.com/audio</a>
Amplifiers	<a href="http://amplifier.ti.com">amplifier.ti.com</a>
Data Converters	<a href="http://dataconverter.ti.com">dataconverter.ti.com</a>
DLP® Products	<a href="http://www.dlp.com">www.dlp.com</a>
DSP	<a href="http://dsp.ti.com">dsp.ti.com</a>
Clocks and Timers	<a href="http://www.ti.com/clocks">www.ti.com/clocks</a>
Interface	<a href="http://interface.ti.com">interface.ti.com</a>
Logic	<a href="http://logic.ti.com">logic.ti.com</a>
Power Mgmt	<a href="http://power.ti.com">power.ti.com</a>
Microcontrollers	<a href="http://microcontroller.ti.com">microcontroller.ti.com</a>
RFID	<a href="http://www.ti-rfid.com">www.ti-rfid.com</a>
OMAP Applications Processors	<a href="http://www.ti.com/omap">www.ti.com/omap</a>
Wireless Connectivity	<a href="http://www.ti.com/wirelessconnectivity">www.ti.com/wirelessconnectivity</a>

### Applications

Automotive and Transportation	<a href="http://www.ti.com/automotive">www.ti.com/automotive</a>
Communications and Telecom	<a href="http://www.ti.com/communications">www.ti.com/communications</a>
Computers and Peripherals	<a href="http://www.ti.com/computers">www.ti.com/computers</a>
Consumer Electronics	<a href="http://www.ti.com/consumer-apps">www.ti.com/consumer-apps</a>
Energy and Lighting	<a href="http://www.ti.com/energy">www.ti.com/energy</a>
Industrial	<a href="http://www.ti.com/industrial">www.ti.com/industrial</a>
Medical	<a href="http://www.ti.com/medical">www.ti.com/medical</a>
Security	<a href="http://www.ti.com/security">www.ti.com/security</a>
Space, Avionics and Defense	<a href="http://www.ti.com/space-avionics-defense">www.ti.com/space-avionics-defense</a>
Video and Imaging	<a href="http://www.ti.com/video">www.ti.com/video</a>

### TI E2E Community

[e2e.ti.com](http://e2e.ti.com)