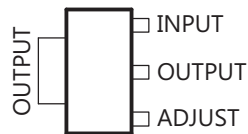
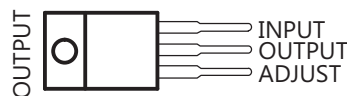
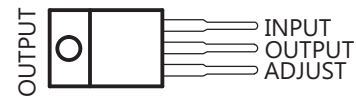
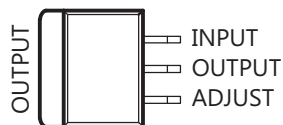
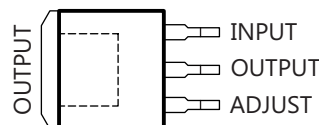

3-TERMINAL ADJUSTABLE REGULATOR

 Check for Samples: [LM317](#)

FEATURES

- Output Voltage Range Adjustable From 1.25 V to 37 V
- Output Current Greater Than 1.5 A
- Internal Short-Circuit Current Limiting
- Thermal Overload Protection
- Output Safe-Area Compensation

**DCY (SOT-223) PACKAGE
(TOP VIEW)**

**KC (TO-220) PACKAGE
(TOP VIEW)**

**KCS / KCT (TO-220) PACKAGE
(TOP VIEW)**

**KTE PACKAGE
(TOP VIEW)**

**KTT (TO-263) PACKAGE
(TOP VIEW)**

DESCRIPTION/ORDERING INFORMATION

The LM317 is an adjustable three-terminal positive-voltage regulator capable of supplying more than 1.5 A over an output-voltage range of 1.25 V to 37 V. It is exceptionally easy to use and requires only two external resistors to set the output voltage. Furthermore, both line and load regulation are better than standard fixed regulators.

In addition to having higher performance than fixed regulators, this device includes on-chip current limiting, thermal overload protection, and safe operating-area protection. All overload protection remains fully functional, even if the ADJUST terminal is disconnected.

The LM317 is versatile in its applications, including uses in programmable output regulation and local on-card regulation. Or, by connecting a fixed resistor between the ADJUST and OUTPUT terminals, the LM317 can function as a precision current regulator. An optional output capacitor can be added to improve transient response. The ADJUST terminal can be bypassed to achieve very high ripple-rejection ratios, which are difficult to achieve with standard three-terminal regulators.

Table 1. ORDERING INFORMATION⁽¹⁾

T _A	PACKAGE ⁽²⁾		ORDERABLE PART NUMBER	TOP-SIDE MARKING
0°C to 125°C	PowerFLEX™ – KTE	Reel of 2000	LM317KTER	OBSOLETE
	SOT-223 – DCY	Tube of 80	LM317DCY	L3
		Reel of 2500	LM317DCYR	
	TO-220 – KC	Tube of 50	LM317KC	OBSOLETE
	TO-220, short shoulder – KCS	Tube of 20	LM317KCS	LM317
	TO-220, short shoulder – KCT	Tube of 20	LM317KCT	LM317
	TO-263 – KTT	Reel of 500	LM317KTTR	LM317

(1) For the most current package and ordering information, see the Package Option Addendum at the end of this document, or see the TI web site at www.ti.com.

(2) Package drawings, thermal data, and symbolization are available at www.ti.com/packaging.



Please be aware that an important notice concerning availability, standard warranty, and use in critical applications of Texas Instruments semiconductor products and disclaimers thereto appears at the end of this data sheet.

PowerFLEX, PowerPAD are trademarks of Texas Instruments.

SCHEMATIC DIAGRAM

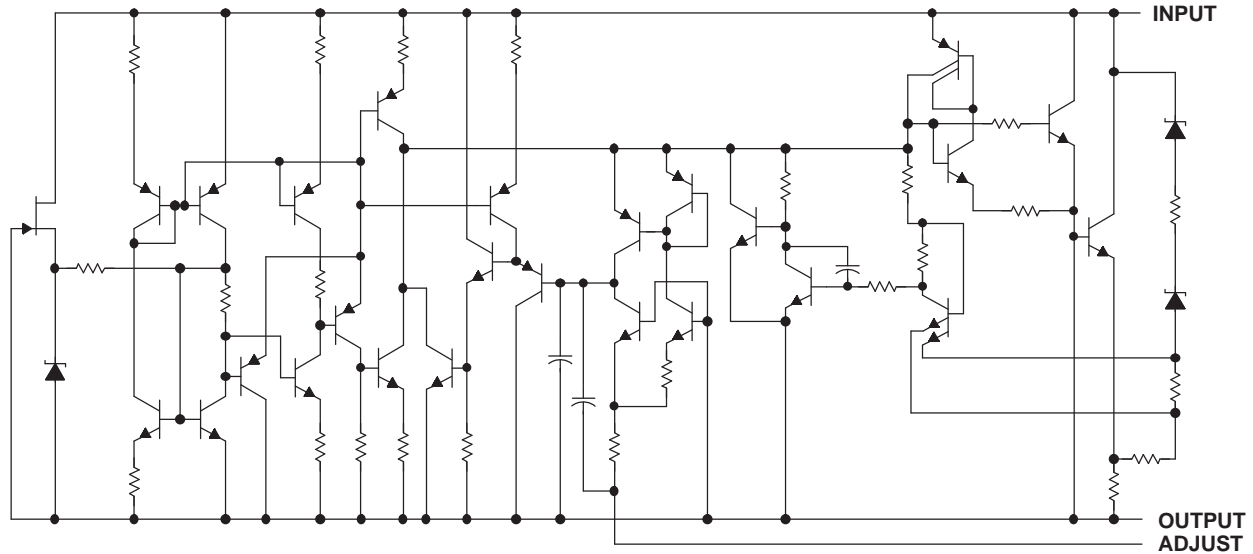
Absolute Maximum Ratings⁽¹⁾

over virtual junction temperature range (unless otherwise noted)

		MIN	MAX	UNIT
$V_I - V_O$	Input-to-output differential voltage		40	V
T_J	Operating virtual junction temperature		150	°C
	Lead temperature 1,6 mm (1/16 in) from case for 10 s		260	°C
T_{stg}	Storage temperature range	-65	150	°C

- (1) Stresses beyond those listed under "absolute maximum ratings" may cause permanent damage to the device. These are stress ratings only, and functional operation of the device at these or any other conditions beyond those indicated under "recommended operating conditions" is not implied. Exposure to absolute-maximum-rated conditions for extended periods may affect device reliability.

Package Thermal Data⁽¹⁾

PACKAGE	BOARD	θ_{JA}	θ_{JC}	θ_{JP} ⁽²⁾
PowerFLEX™ (KTE)	High K, JESD 51-5	23°C/W	11.6°C/W	
SOT-223 (DCY)	High K, JESD 51-7	53°C/W	30.6°C/W	
TO-220 (KC/KCS/KCT)	High K, JESD 51-5	19°C/W	17°C/W	3°C/W
TO-263 (KTT)	High K, JESD 51-5	25.3°C/W	18°C/W	1.94°C/W

- (1) Maximum power dissipation is a function of $T_J(\max)$, θ_{JA} , and T_A . The maximum allowable power dissipation at any allowable ambient temperature is $P_D = (T_J(\max) - T_A)/\theta_{JA}$. Operating at the absolute maximum T_J of 150°C can affect reliability.
- (2) For packages with exposed thermal pads, such as QFN, PowerPAD™, or PowerFLEX™, θ_{JP} is defined as the thermal resistance between the die junction and the bottom of the exposed pad.

Recommended Operating Conditions

		MIN	MAX	UNIT
$V_I - V_O$	Input-to-output differential voltage	3	40	V
I_O	Output current		1.5	A
T_J	Operating virtual junction temperature	0	125	°C

Electrical Characteristics

over recommended ranges of operating virtual junction temperature (unless otherwise noted)

PARAMETER	TEST CONDITIONS ⁽¹⁾		MIN	TYP	MAX	UNIT
Line regulation ⁽²⁾	$V_I - V_O = 3\text{ V to }40\text{ V}$	$T_J = 25^\circ\text{C}$		0.01	0.04	%V
		$T_J = 0^\circ\text{C to }125^\circ\text{C}$		0.02	0.07	
Load regulation	$I_O = 10\text{ mA to }1500\text{ mA}$	$C_{ADJ} = 10\ \mu\text{F}$, ⁽³⁾ $T_J = 25^\circ\text{C}$	$V_O \leq 5\text{ V}$		25	mV
			$V_O \geq 5\text{ V}$	0.1	0.5	% V_O
		$T_J = 0^\circ\text{C to }125^\circ\text{C}$	$V_O \leq 5\text{ V}$	20	70	mV
			$V_O \geq 5\text{ V}$	0.3	1.5	% V_O
Thermal regulation	20-ms pulse,	$T_J = 25^\circ\text{C}$		0.03	0.07	% V_O/W
ADJUST terminal current				50	100	μA
Change in ADJUST terminal current	$V_I - V_O = 2.5\text{ V to }40\text{ V}$, $P_D \leq 20\text{ W}$, $I_O = 10\text{ mA to }1500\text{ mA}$			0.2	5	μA
Reference voltage	$V_I - V_O = 3\text{ V to }40\text{ V}$, $P_D \leq 20\text{ W}$, $I_O = 10\text{ mA to }1500\text{ mA}$		1.2	1.25	1.3	V
Output-voltage temperature stability	$T_J = 0^\circ\text{C to }125^\circ\text{C}$			0.7		% V_O
Minimum load current to maintain regulation	$V_I - V_O = 40\text{ V}$			3.5	10	mA
Maximum output current	$V_I - V_O \leq 15\text{ V}$,	$P_D < P_{MAX}$ ⁽⁴⁾	1.5	2.2		A
	$V_I - V_O \leq 40\text{ V}$,	$P_D < P_{MAX}$ ⁽⁴⁾ , $T_J = 25^\circ\text{C}$	0.15	0.4		
RMS output noise voltage (% of V_O)	$f = 10\text{ Hz to }10\text{ kHz}$,	$T_J = 25^\circ\text{C}$		0.003		% V_O
Ripple rejection	$V_O = 10\text{ V}$,	$f = 120\text{ Hz}$	$C_{ADJ} = 0\ \mu\text{F}$ ⁽³⁾	57		dB
			$C_{ADJ} = 10\ \mu\text{F}$ ⁽³⁾	62	64	
Long-term stability	$T_J = 25^\circ\text{C}$			0.3	1	%/1k hr

- (1) Unless otherwise noted, the following test conditions apply: $|V_I - V_O| = 5\text{ V}$ and $I_{O\text{MAX}} = 1.5\text{ A}$, $T_J = 0^\circ\text{C to }125^\circ\text{C}$. Pulse testing techniques are used to maintain the junction temperature as close to the ambient temperature as possible.
- (2) Line regulation is expressed here as the percentage change in output voltage per 1-V change at the input.
- (3) C_{ADJ} is connected between the ADJUST terminal and GND.
- (4) Maximum power dissipation is a function of $T_J(\text{max})$, θ_{JA} , and T_A . The maximum allowable power dissipation at any allowable ambient temperature is $P_D = (T_J(\text{max}) - T_A)/\theta_{JA}$. Operating at the absolute maximum T_J of 150°C can affect reliability.

TYPICAL CHARACTERISTICS

LOAD REGULATION

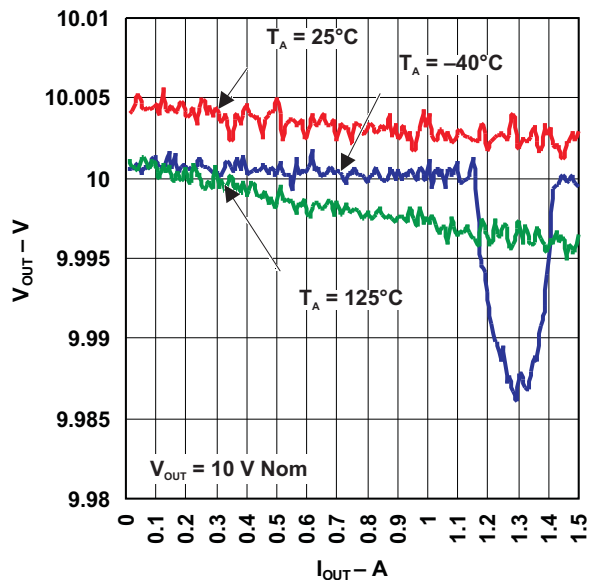

LOAD REGULATION

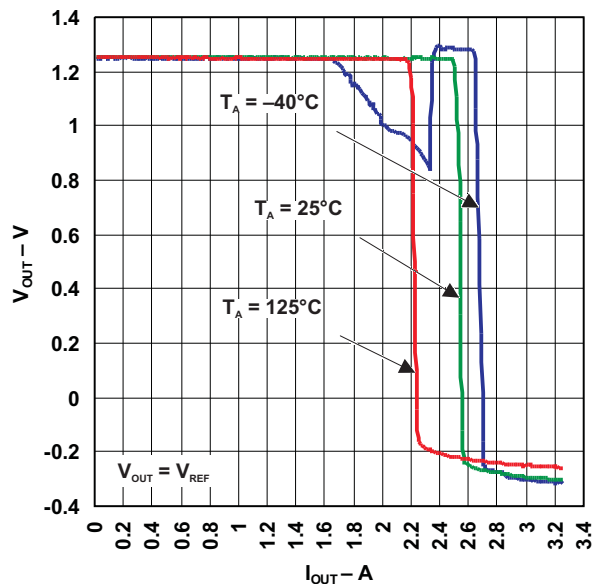

LOAD TRANSIENT RESPONSE

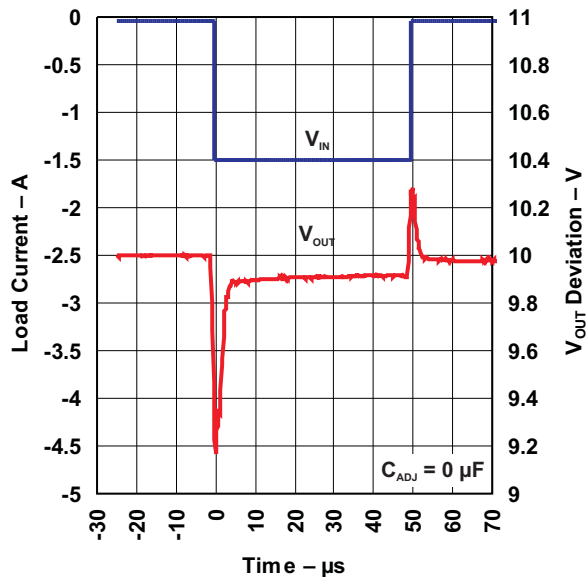

LOAD TRANSIENT RESPONSE

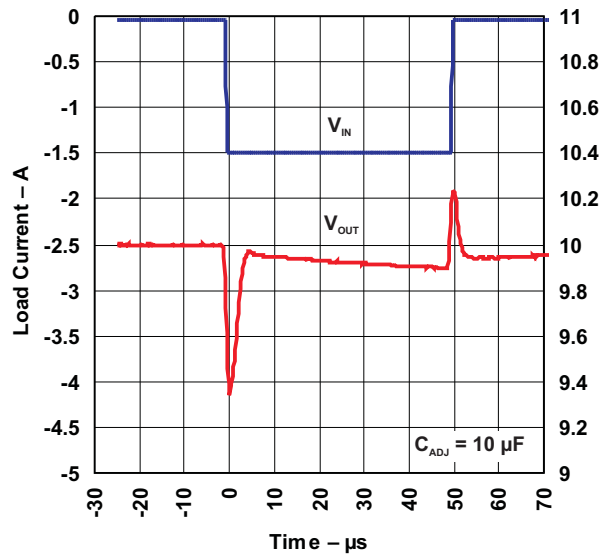

TYPICAL CHARACTERISTICS (continued)
 LINE REGULATION LINE TRANSIENT RESPONSE

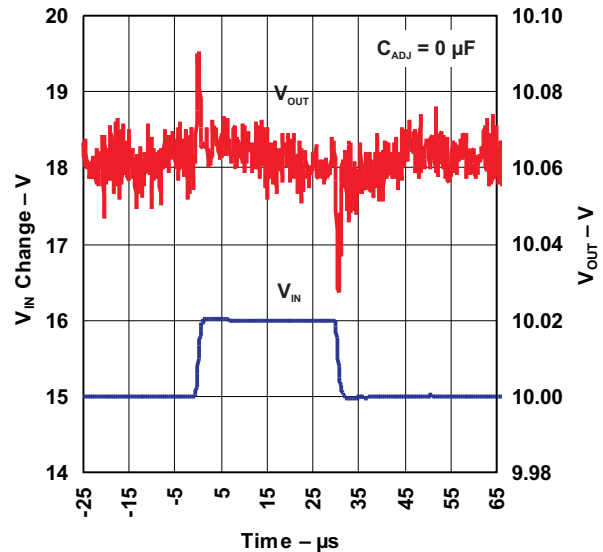
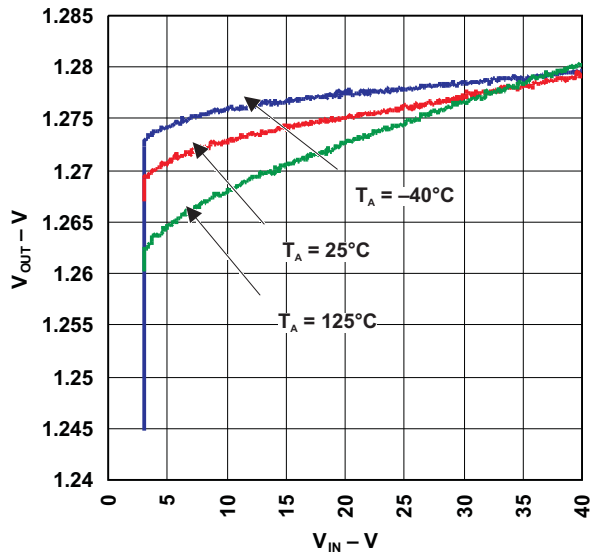

LINE TRANSIENT RESPONSE

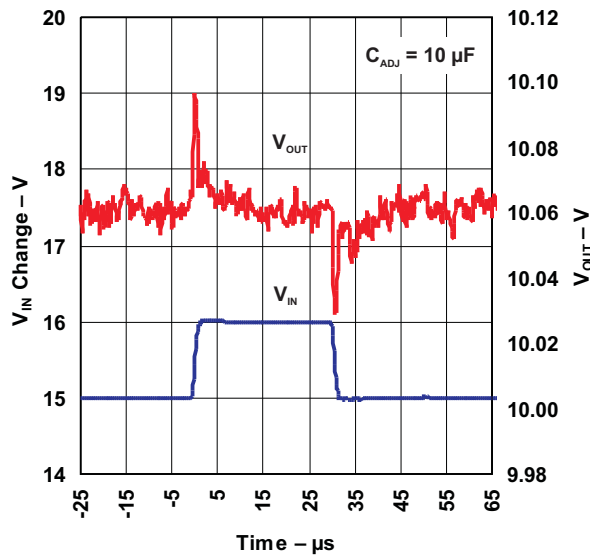

RIPPLE REJECTION
 vs
 FREQUENCY

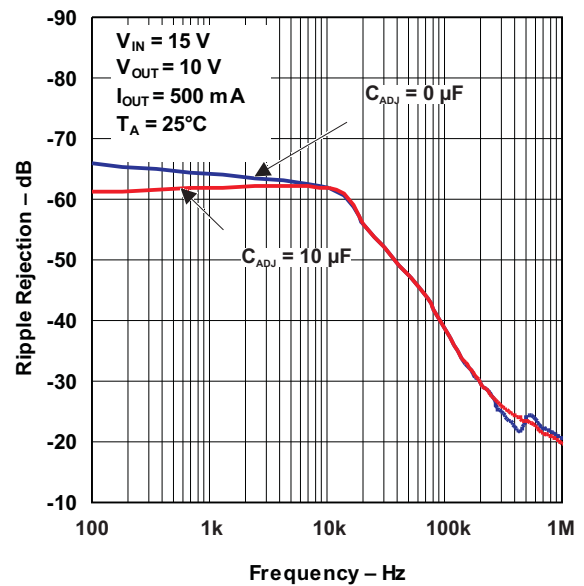

TYPICAL CHARACTERISTICS (continued)

**RIPPLE REJECTION
VS
OUTPUT CURRENT**

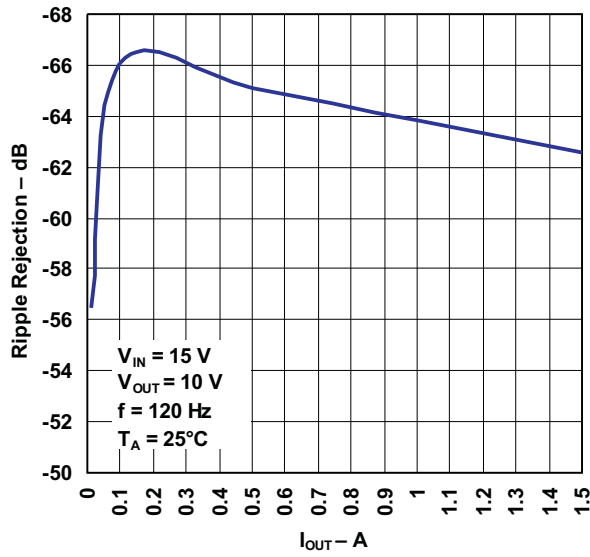

**RIPPLE REJECTION
VS
OUTPUT VOLTAGE**

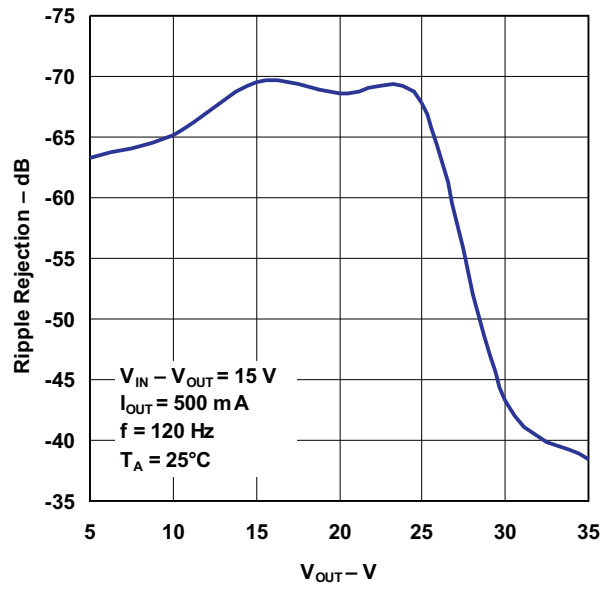

APPLICATION INFORMATION

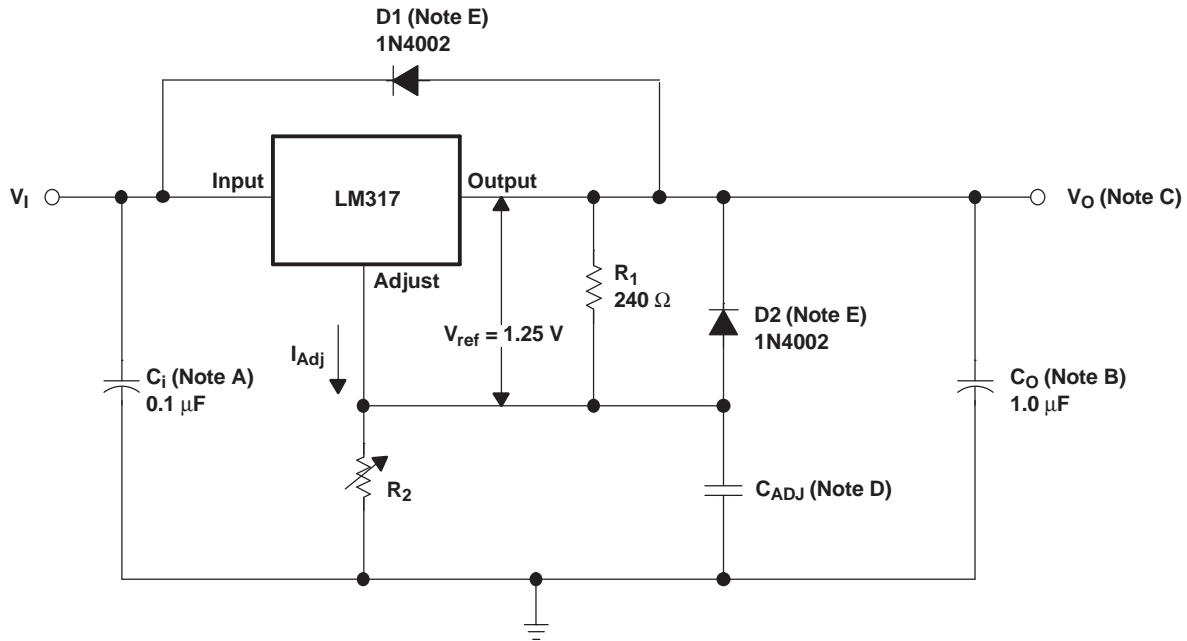

- NOTES: A. C_i is not required, but is recommended, particularly if the regulator is not in close proximity to the power-supply filter capacitors. A 0.1- μ F disc or 1- μ F tantalum provides sufficient bypassing for most applications, especially when adjustment and output capacitors are used.
- B. C_O improves transient response, but is not needed for stability.
- C. V_O is calculated as shown:

$$V_O = V_{ref} \left(1 + \frac{R_2}{R_1} \right) + (I_{Adj} \times R_2)$$

Because I_{Adj} typically is 50 μ A, it is negligible in most applications.

- D. C_{ADJ} is used to improve ripple rejection; it prevents amplification of the ripple as the output voltage is adjusted higher. If C_{ADJ} is used, it is best to include protection diodes.
- E. If the input is shorted to ground during a fault condition, protection diodes provide measures to prevent the possibility of external capacitors discharging through low-impedance paths in the IC. By providing low-impedance discharge paths for C_O and C_{ADJ} , respectively, D1 and D2 prevent the capacitors from discharging into the output of the regulator.

Figure 1. Adjustable Voltage Regulator

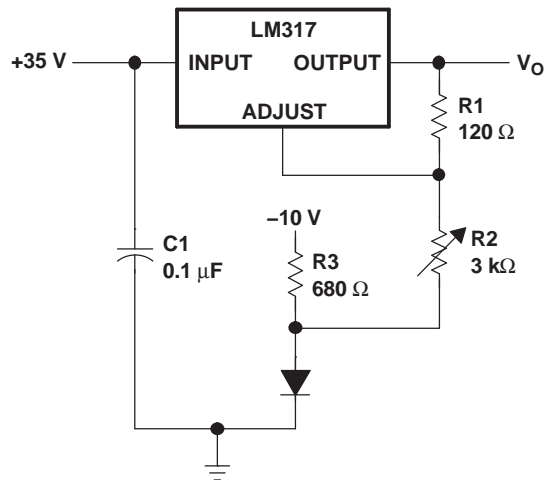

V_O is calculated as:

$$V_O = V_{ref} \left(1 + \frac{R2 + R3}{R1} \right) + I_{Adj}(R2 + R3) - 10 \text{ V}$$

Since I_{Adj} typically is 50 μA , it is negligible in most applications.

Figure 2. 0-V to 30-V Regulator Circuit

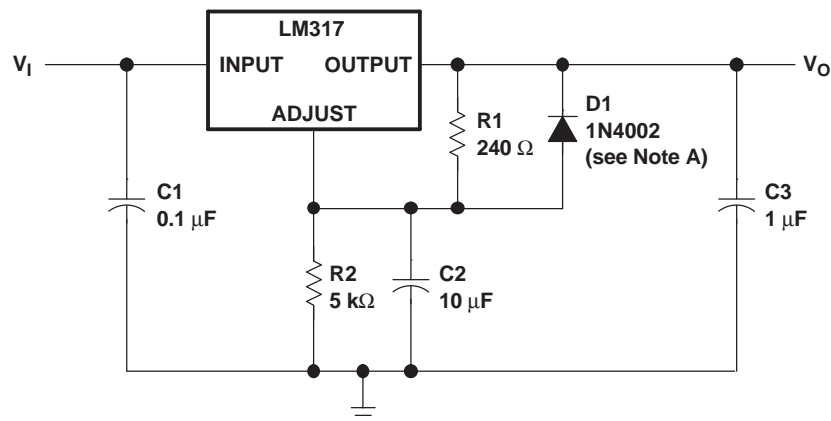

NOTE A: D1 discharges C2 if the output is shorted to ground.

Figure 3. Adjustable Regulator Circuit With Improved Ripple Rejection

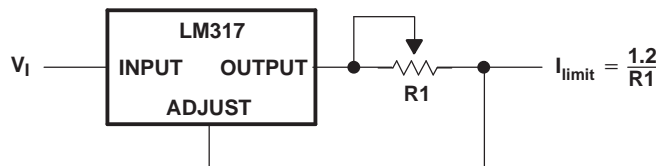

Figure 4. Precision Current-Limiter Circuit

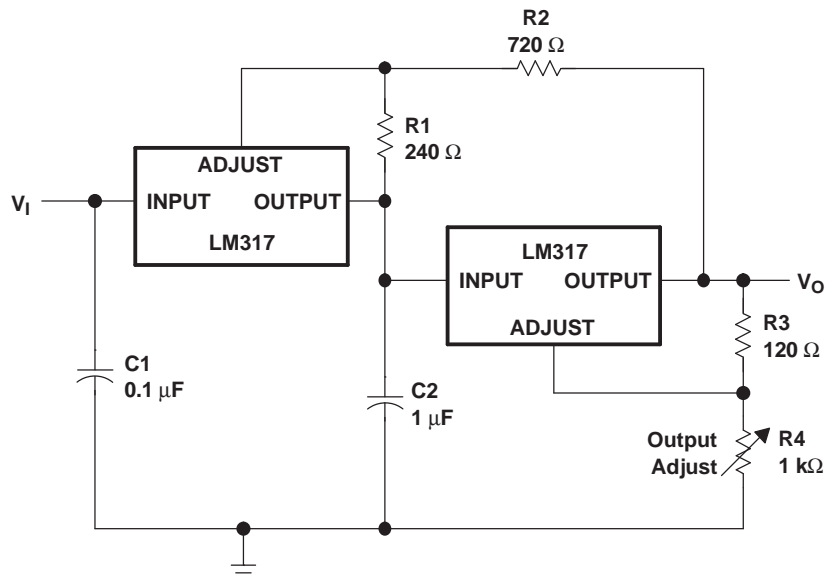

Figure 5. Tracking Preregulator Circuit

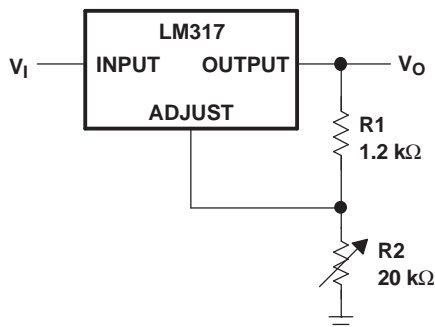
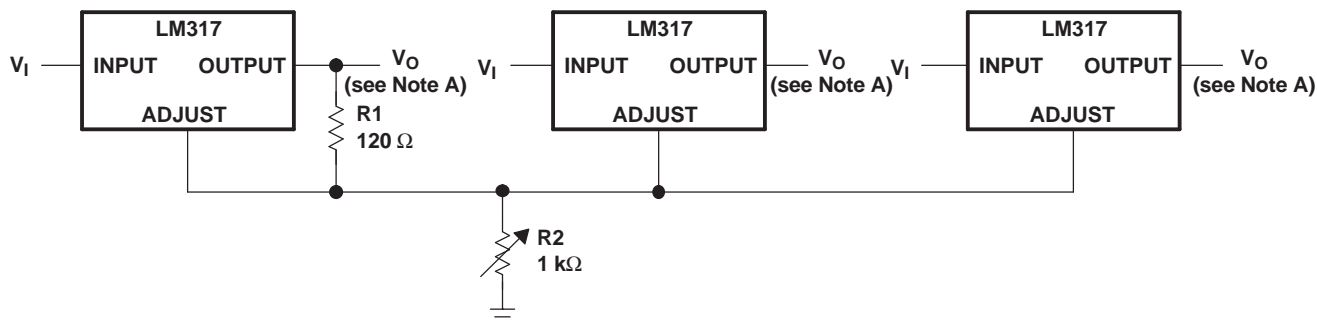
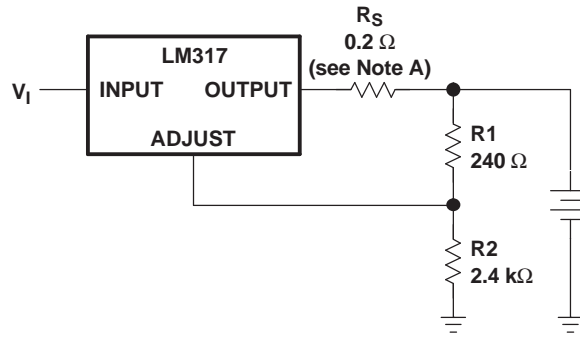

Figure 6. 1.25-V to 20-V Regulator Circuit With Minimum Program Current



NOTE A: Minimum load current from each output is 10 mA. All output voltages are within 200 mV of each other.

Figure 7. Adjusting Multiple On-Card Regulators With a Single Control



NOTE A: R_S controls the output impedance of the charger.

$$Z_{OUT} = R_S \left(1 + \frac{R_2}{R_1} \right)$$

The use of R_S allows for low charging rates with a fully charged battery.

Figure 8. Battery-Charger Circuit

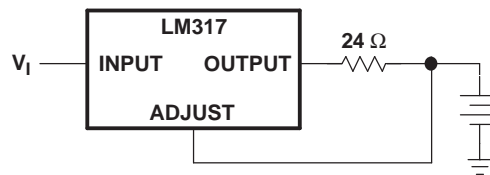

Figure 9. 50-mA Constant-Current Battery-Charger Circuit

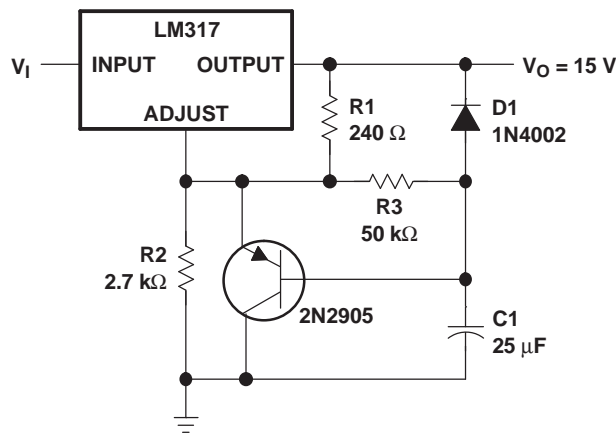

Figure 10. Slow Turn-On 15-V Regulator Circuit

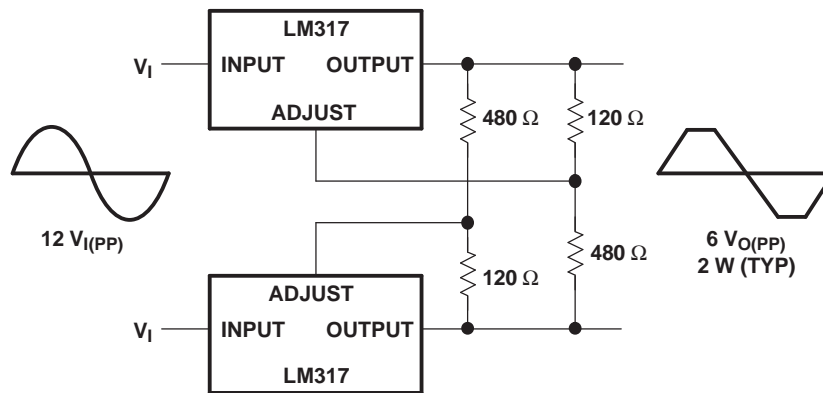
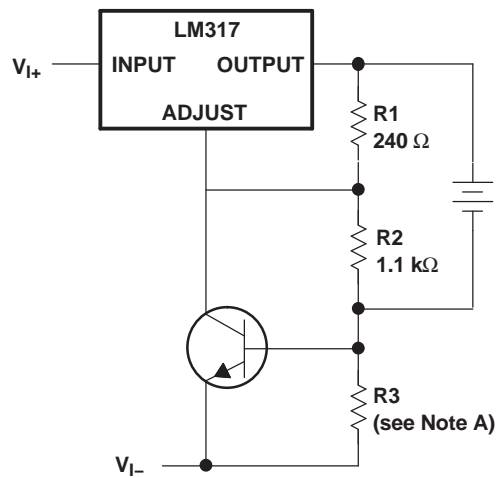

Figure 11. AC Voltage-Regulator Circuit



NOTE A: R3 sets the peak current (0.6 A for a 1-Ω resistor).

Figure 12. Current-Limited 6-V Charger Circuit

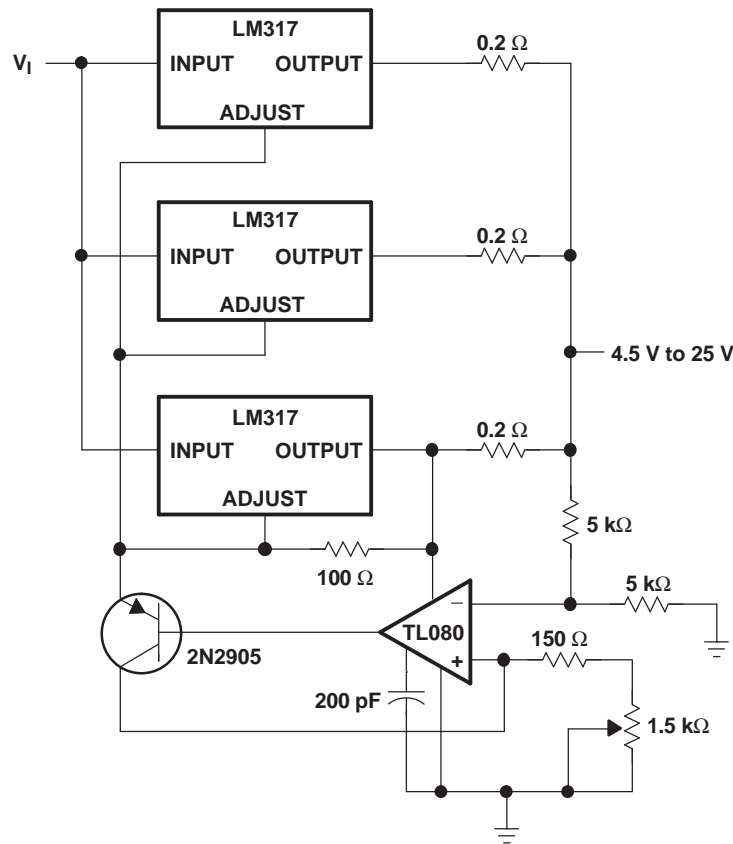
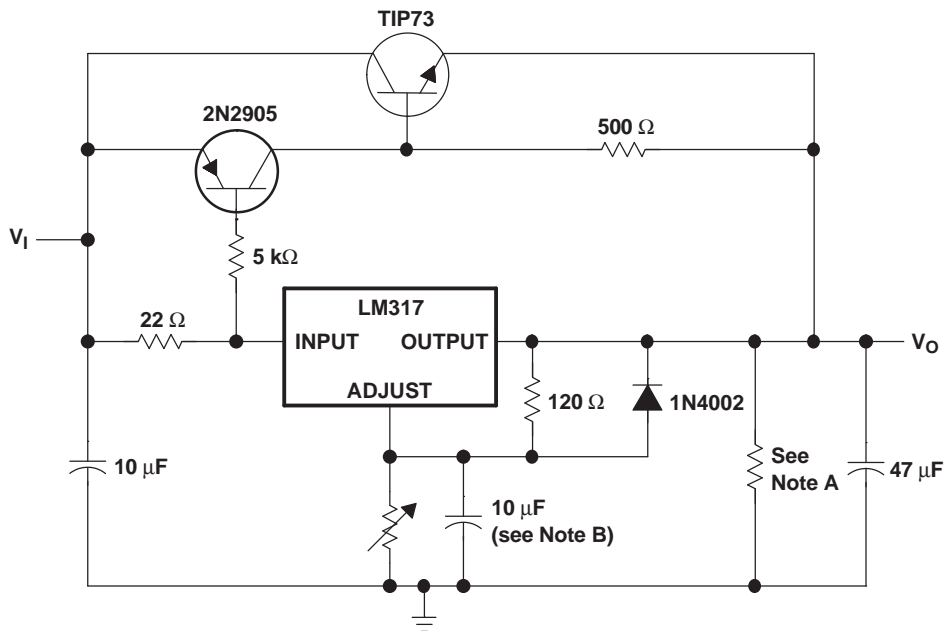

Figure 13. Adjustable 4-A Regulator Circuit



- NOTES: A. The minimum load current is 30 mA.
 B. This optional capacitor improves ripple rejection.

Figure 14. High-Current Adjustable Regulator Circuit

Changes from Revision U (Apr 2008) to Revision V**Page**

-
- Added KCT orderable part information 1
-

PACKAGING INFORMATION

Orderable Device	Status (1)	Package Type	Package Drawing	Pins	Package Qty	Eco Plan (2)	Lead/Ball Finish	MSL Peak Temp (3)	Op Temp (°C)	Top-Side Markings (4)	Samples
LM317DCY	ACTIVE	SOT-223	DCY	4	80	Green (RoHS & no Sb/Br)	CU SN	Level-2-260C-1 YEAR	0 to 125	L3	Samples
LM317DCYG3	ACTIVE	SOT-223	DCY	4	80	Green (RoHS & no Sb/Br)	CU SN	Level-2-260C-1 YEAR	0 to 125	L3	Samples
LM317DCYR	ACTIVE	SOT-223	DCY	4	2500	Green (RoHS & no Sb/Br)	CU SN	Level-2-260C-1 YEAR	0 to 125	L3	Samples
LM317DCYRG3	ACTIVE	SOT-223	DCY	4	2500	Green (RoHS & no Sb/Br)	CU SN	Level-2-260C-1 YEAR	0 to 125	L3	Samples
LM317KC	OBSOLETE	TO-220	KC	3		TBD	Call TI	Call TI	0 to 125	LM317	
LM317KCE3	OBSOLETE	TO-220	KC	3		TBD	Call TI	Call TI	0 to 125	LM317	
LM317KCS	ACTIVE	TO-220	KCS	3	50	Pb-Free (RoHS)	CU SN	N / A for Pkg Type	0 to 125	LM317	Samples
LM317KCSE3	ACTIVE	TO-220	KCS	3	50	Pb-Free (RoHS)	CU SN	N / A for Pkg Type	0 to 125	LM317	Samples
LM317KCT	ACTIVE	TO-220	KCT	3	50	Pb-Free (RoHS)	CU SN	N / A for Pkg Type	0 to 125		Samples
LM317KTER	OBSOLETE	PFM	KTE	3		TBD	Call TI	Call TI	0 to 125	LM317	
LM317KTTR	ACTIVE	DDPAK/ TO-263	KTT	3	500	Green (RoHS & no Sb/Br)	CU SN	Level-3-245C-168 HR	0 to 125	LM317	Samples
LM317KTTRG3	ACTIVE	DDPAK/ TO-263	KTT	3	500	Green (RoHS & no Sb/Br)	CU SN	Level-3-245C-168 HR	0 to 125	LM317	Samples

(1) The marketing status values are defined as follows:

ACTIVE: Product device recommended for new designs.

LIFEBUY: TI has announced that the device will be discontinued, and a lifetime-buy period is in effect.

NRND: Not recommended for new designs. Device is in production to support existing customers, but TI does not recommend using this part in a new design.

PREVIEW: Device has been announced but is not in production. Samples may or may not be available.

OBSOLETE: TI has discontinued the production of the device.

(2) Eco Plan - The planned eco-friendly classification: Pb-Free (RoHS), Pb-Free (RoHS Exempt), or Green (RoHS & no Sb/Br) - please check <http://www.ti.com/productcontent> for the latest availability information and additional product content details.

TBD: The Pb-Free/Green conversion plan has not been defined.

Pb-Free (RoHS): TI's terms "Lead-Free" or "Pb-Free" mean semiconductor products that are compatible with the current RoHS requirements for all 6 substances, including the requirement that lead not exceed 0.1% by weight in homogeneous materials. Where designed to be soldered at high temperatures, TI Pb-Free products are suitable for use in specified lead-free processes.

Pb-Free (RoHS Exempt): This component has a RoHS exemption for either 1) lead-based flip-chip solder bumps used between the die and package, or 2) lead-based die adhesive used between the die and leadframe. The component is otherwise considered Pb-Free (RoHS compatible) as defined above.

Green (RoHS & no Sb/Br): TI defines "Green" to mean Pb-Free (RoHS compatible), and free of Bromine (Br) and Antimony (Sb) based flame retardants (Br or Sb do not exceed 0.1% by weight in homogeneous material)

(3) MSL, Peak Temp. -- The Moisture Sensitivity Level rating according to the JEDEC industry standard classifications, and peak solder temperature.

(4) Only one of markings shown within the brackets will appear on the physical device.

Important Information and Disclaimer: The information provided on this page represents TI's knowledge and belief as of the date that it is provided. TI bases its knowledge and belief on information provided by third parties, and makes no representation or warranty as to the accuracy of such information. Efforts are underway to better integrate information from third parties. TI has taken and continues to take reasonable steps to provide representative and accurate information but may not have conducted destructive testing or chemical analysis on incoming materials and chemicals. TI and TI suppliers consider certain information to be proprietary, and thus CAS numbers and other limited information may not be available for release.

In no event shall TI's liability arising out of such information exceed the total purchase price of the TI part(s) at issue in this document sold by TI to Customer on an annual basis.

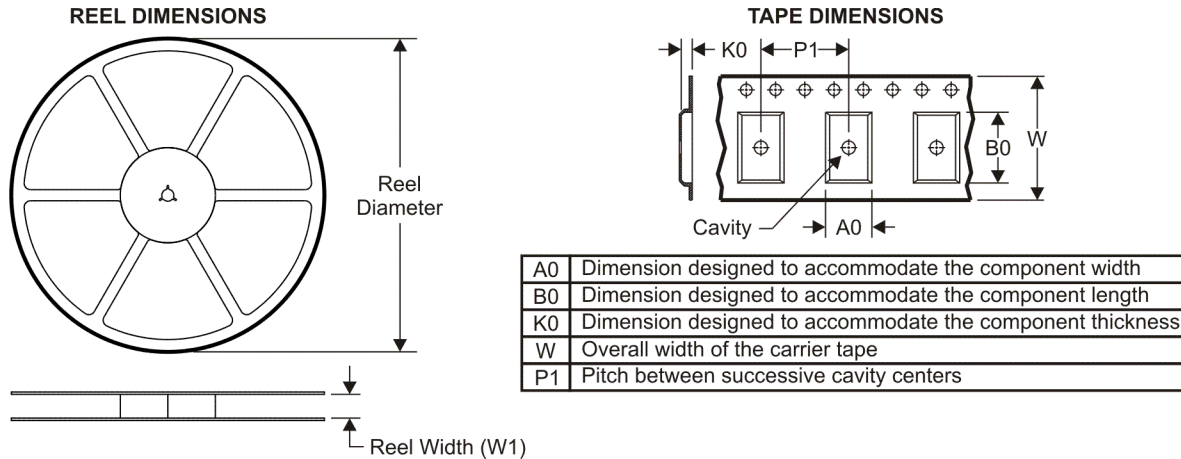
TAPE AND REEL INFORMATION

QUADRANT ASSIGNMENTS FOR PIN 1 ORIENTATION IN TAPE

*All dimensions are nominal

Device	Package Type	Package Drawing	Pins	SPQ	Reel Diameter (mm)	Reel Width W1 (mm)	A0 (mm)	B0 (mm)	K0 (mm)	P1 (mm)	W (mm)	Pin1 Quadrant
LM317DCYR	SOT-223	DCY	4	2500	330.0	12.4	7.05	7.4	1.9	8.0	12.0	Q3
LM317KTTR	DDPAK/ TO-263	KTT	3	500	330.0	24.4	10.6	15.8	4.9	16.0	24.0	Q2

TAPE AND REEL BOX DIMENSIONS

*All dimensions are nominal

Device	Package Type	Package Drawing	Pins	SPQ	Length (mm)	Width (mm)	Height (mm)
LM317DCYR	SOT-223	DCY	4	2500	340.0	340.0	38.0
LM317KTTR	DDPAK/TO-263	KTT	3	500	340.0	340.0	38.0

DCY (R-PDSO-G4)

PLASTIC SMALL-OUTLINE

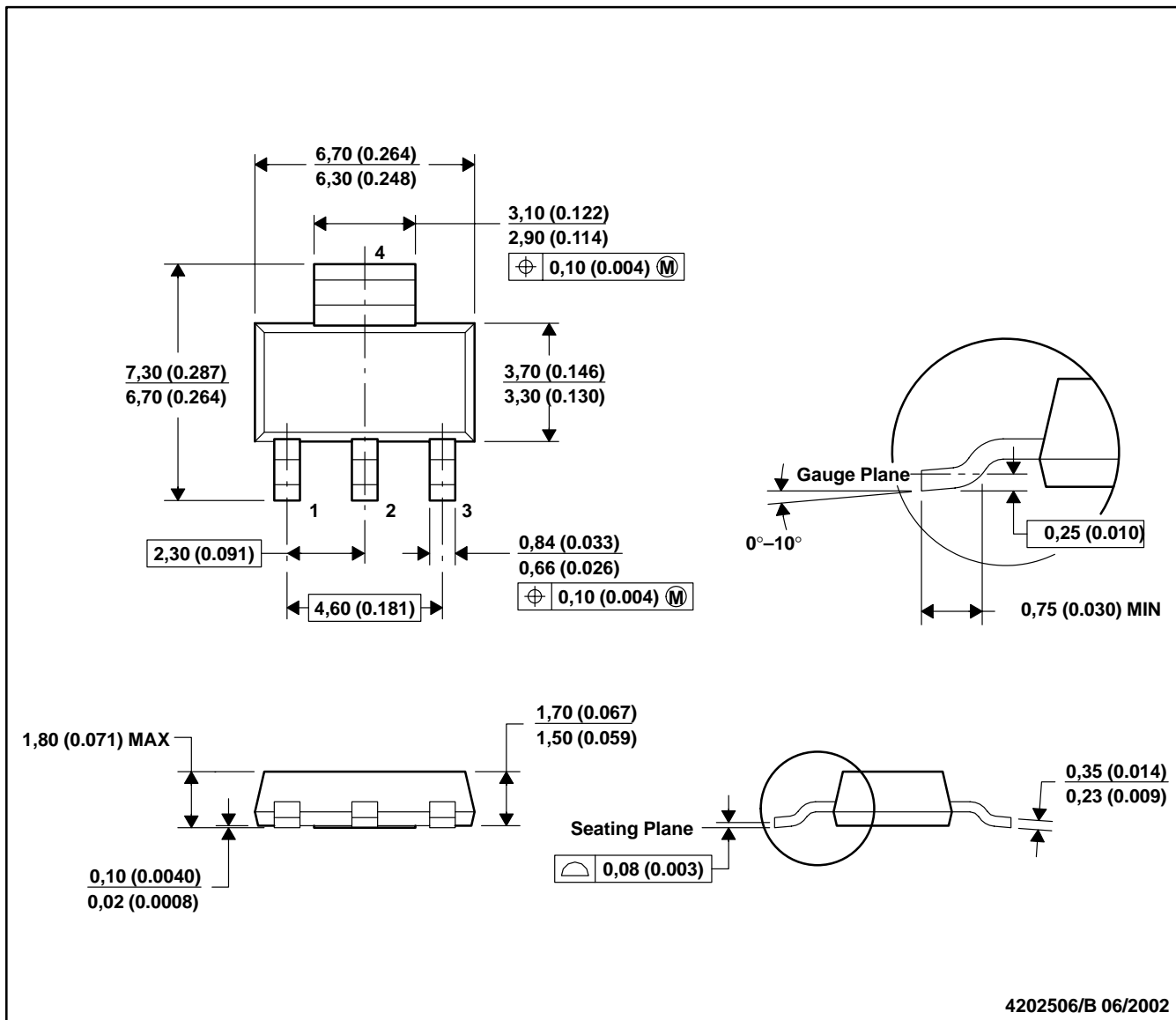

- NOTES: A. All linear dimensions are in millimeters (inches).
 B. This drawing is subject to change without notice.
 C. Body dimensions do not include mold flash or protrusion.
 D. Falls within JEDEC TO-261 Variation AA.

DCY (R-PDSO-G4)

PLASTIC SMALL OUTLINE

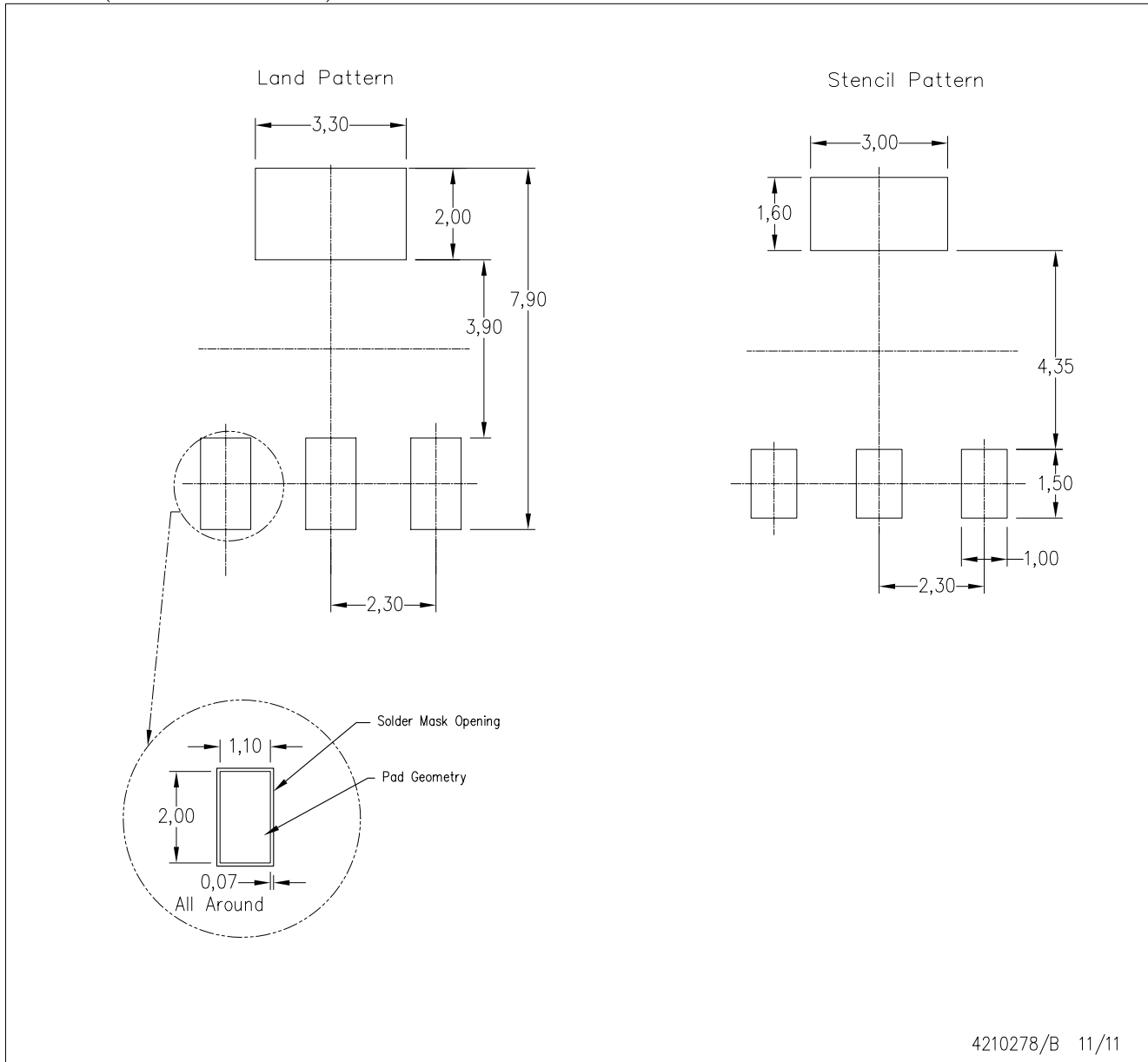

- NOTES:
- A. All linear dimensions are in millimeters.
 - B. This drawing is subject to change without notice.
 - C. Customers should place a note on the circuit board fabrication drawing not to alter the center solder mask defined pad.
 - D. Publication IPC-7351 is recommended for alternate designs.
 - E. Laser cutting apertures with trapezoidal walls and also rounding corners will offer better paste release. Customers should contact their board assembly site for stencil design recommendations.

KTE (R-PSFM-G3)

PowerFLEX™ PLASTIC FLANGE-MOUNT

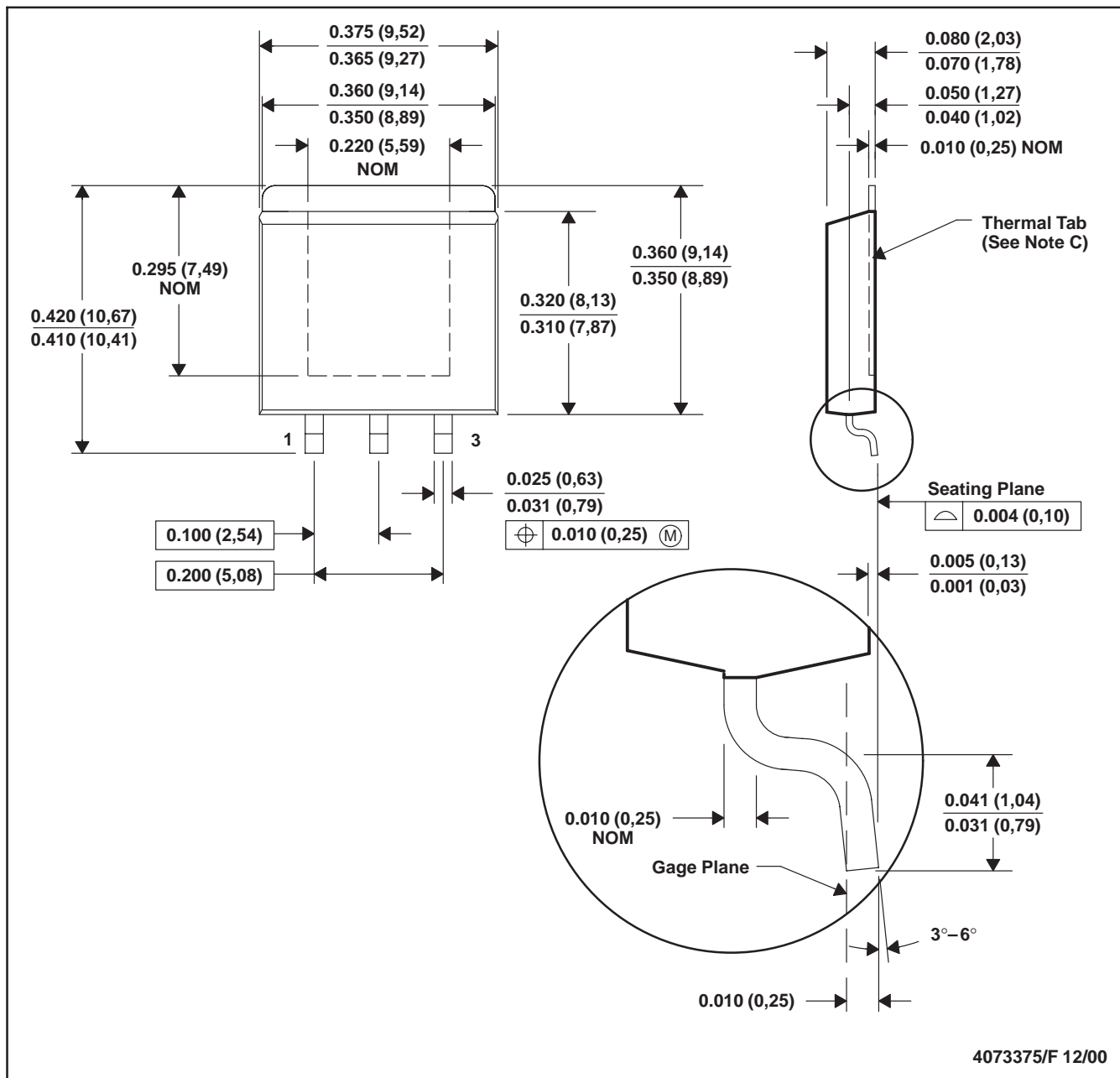

- NOTES: A. All linear dimensions are in inches (millimeters).
 B. This drawing is subject to change without notice.
 C. The center lead is in electrical contact with the thermal tab.
 D. Dimensions do not include mold protrusions, not to exceed 0.006 (0,15).
 E. Falls within JEDEC MO-169

PowerFLEX is a trademark of Texas Instruments.



KTT (R-PSFM-G3)

PLASTIC FLANGE-MOUNT PACKAGE

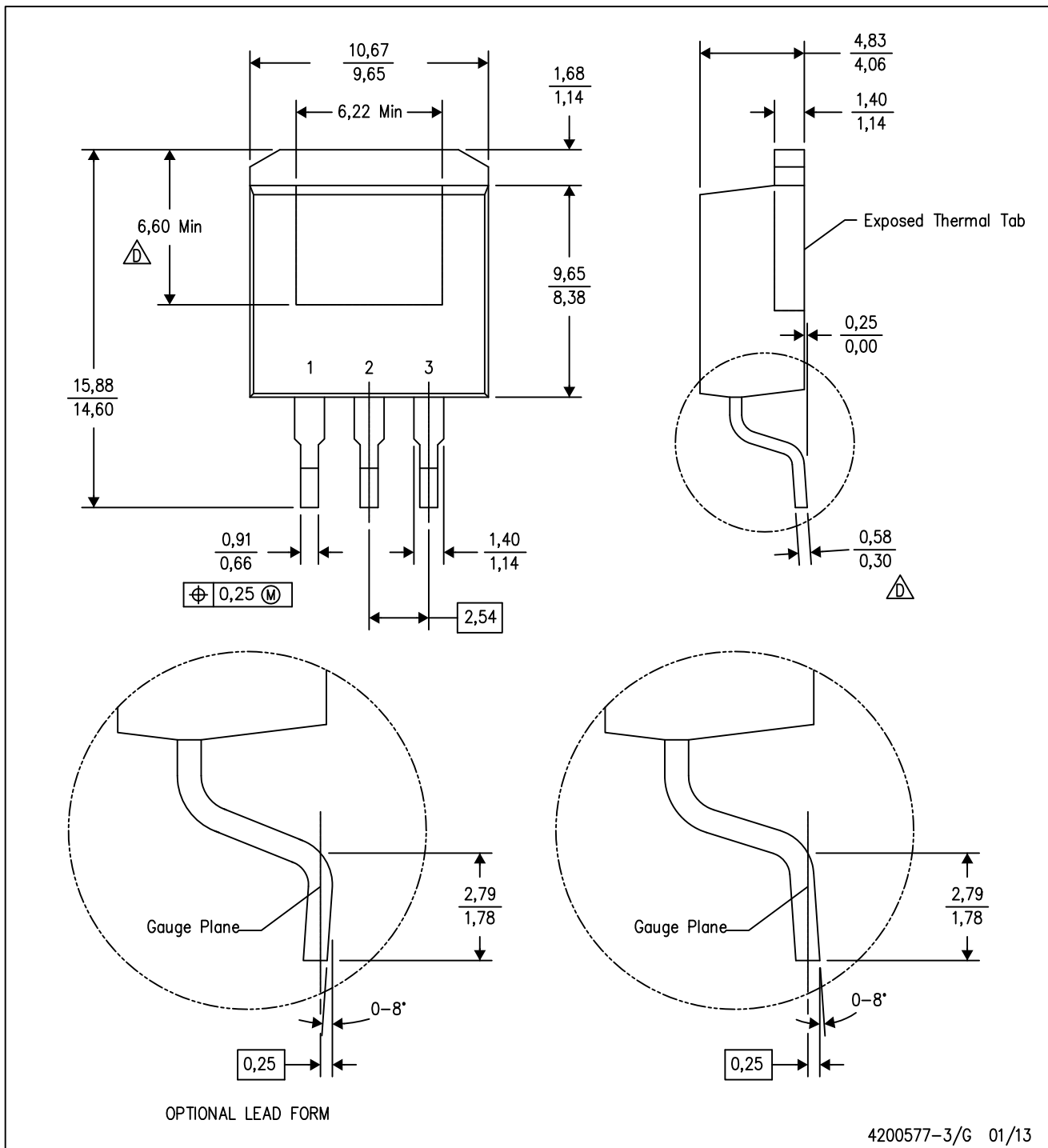

4200577-3/G 01/13

- NOTES:
- All linear dimensions are in millimeters.
 - This drawing is subject to change without notice.
 - Body dimensions do not include mold flash or protrusion. Mold flash or protrusion not to exceed 0.005 (0,13) per side.
 - \triangle Falls within JEDEC TO-263 variation AA, except minimum lead thickness and minimum exposed pad length.

KTT (R-PSFM-G3)

PLASTIC FLANGE-MOUNT PACKAGE

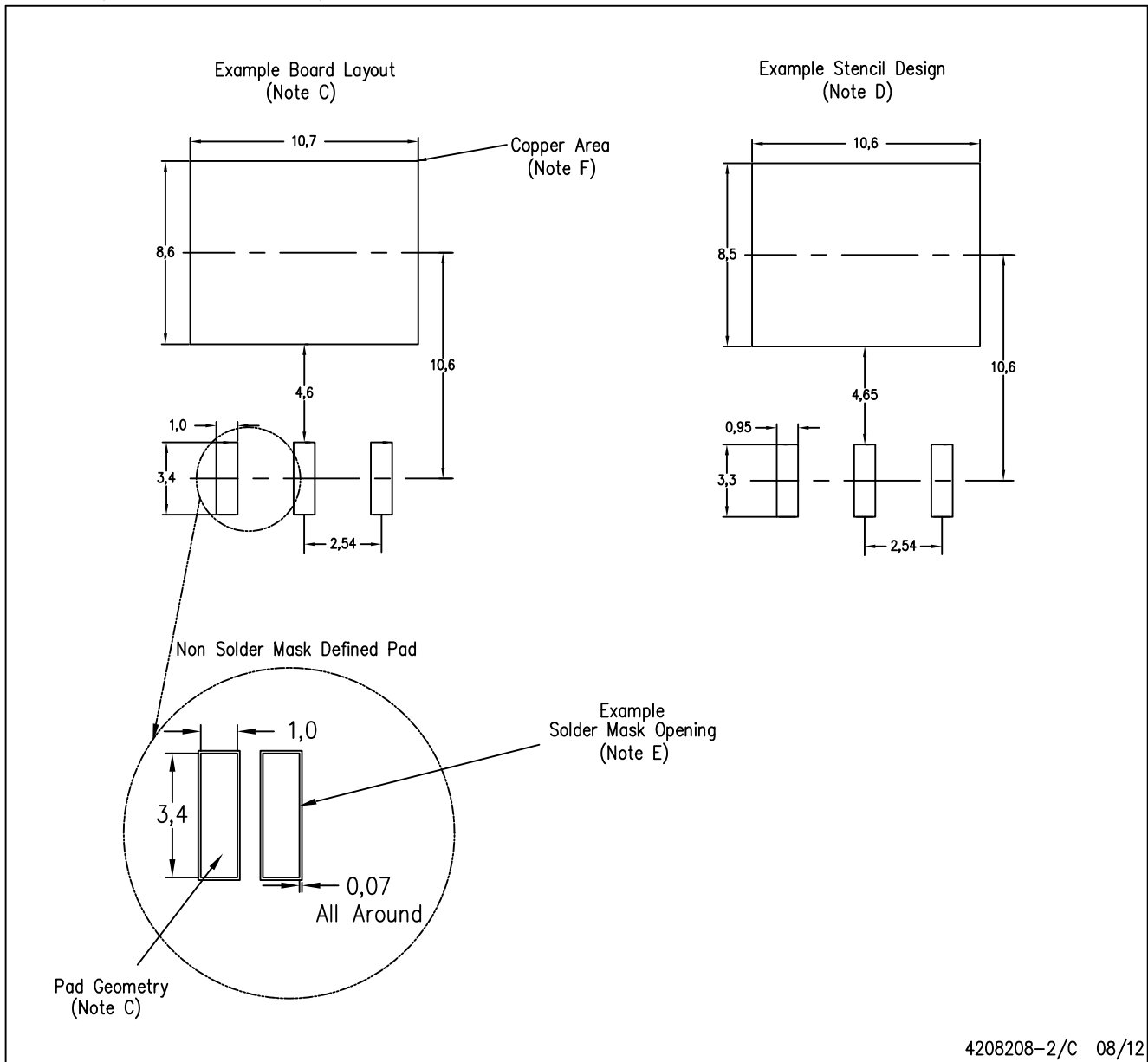

4208208-2/C 08/12

- NOTES:
- All linear dimensions are in millimeters.
 - This drawing is subject to change without notice.
 - Publication IPC-SM-782 is recommended for alternate designs.
 - Laser cutting apertures with trapezoidal walls and also rounding corners will offer better paste release. Customers should contact their board assembly site for stencil design recommendations. Refer to IPC-7525.
 - Customers should contact their board fabrication site for solder mask tolerances between and around signal pads.
 - This package is designed to be soldered to a thermal pad on the board. Refer to the Product Datasheet for specific thermal information, via requirements, and recommended thermal pad size. For thermal pad sizes larger than shown a solder mask defined pad is recommended in order to maintain the solderable pad geometry while increasing copper area.

KCS (R-PSFM-T3)

PLASTIC FLANGE-MOUNT PACKAGE

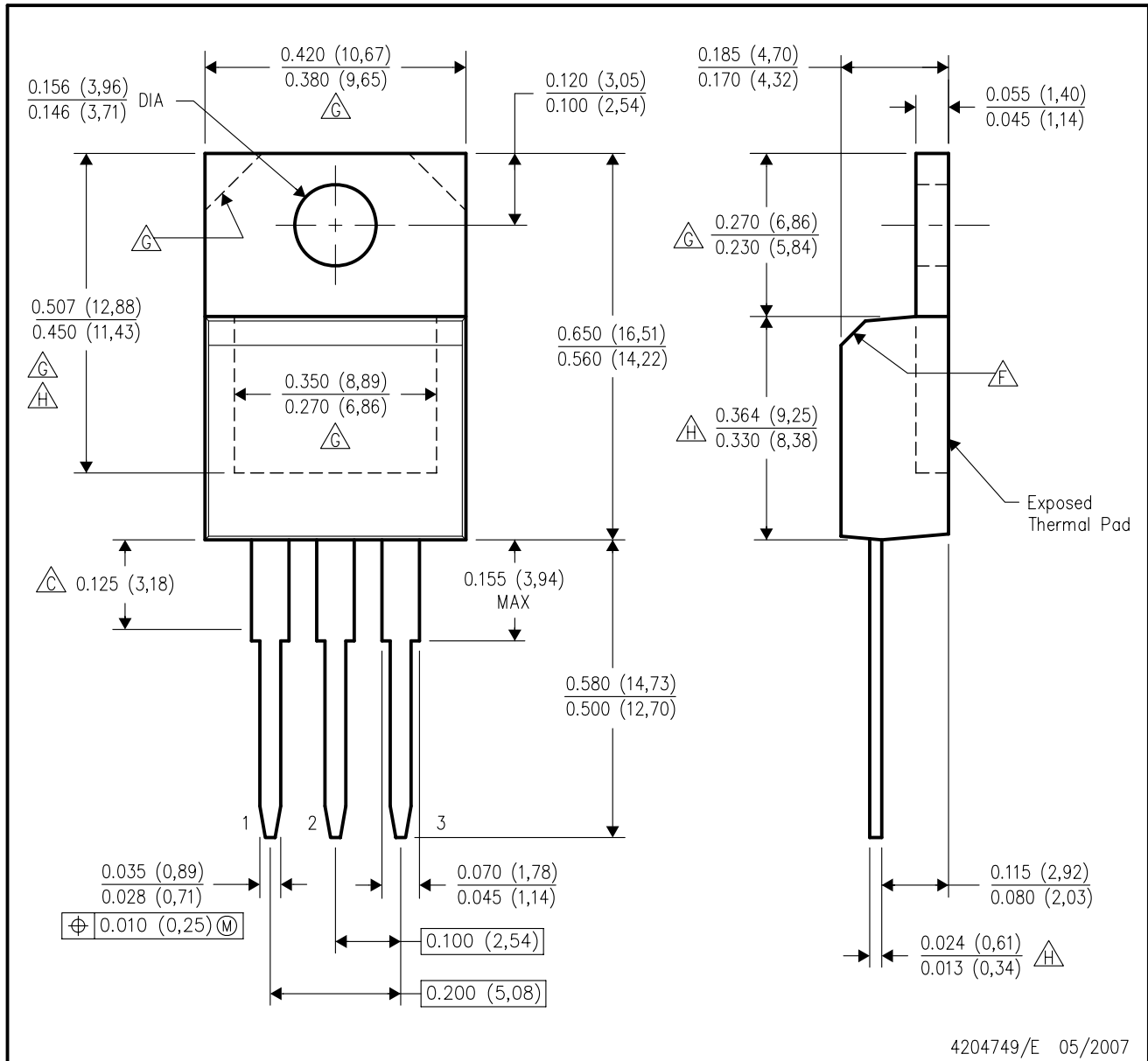

- NOTES:
- A. All linear dimensions are in inches (millimeters).
 - B. This drawing is subject to change without notice.
 - $\triangle C$ Lead dimensions are not controlled within this area.
 - D. All lead dimensions apply before solder dip.
 - E. The center lead is in electrical contact with the mounting tab.
 - $\triangle F$ The chamfer is optional.
 - $\triangle G$ Thermal pad contour optional within these dimensions.
 - $\triangle H$ Falls within JEDEC TO-220 variation AB, except minimum lead thickness, minimum exposed pad length, and maximum body length.

KCT (R-PSFM-T3)

PLASTIC FLANGE-MOUNT PACKAGE

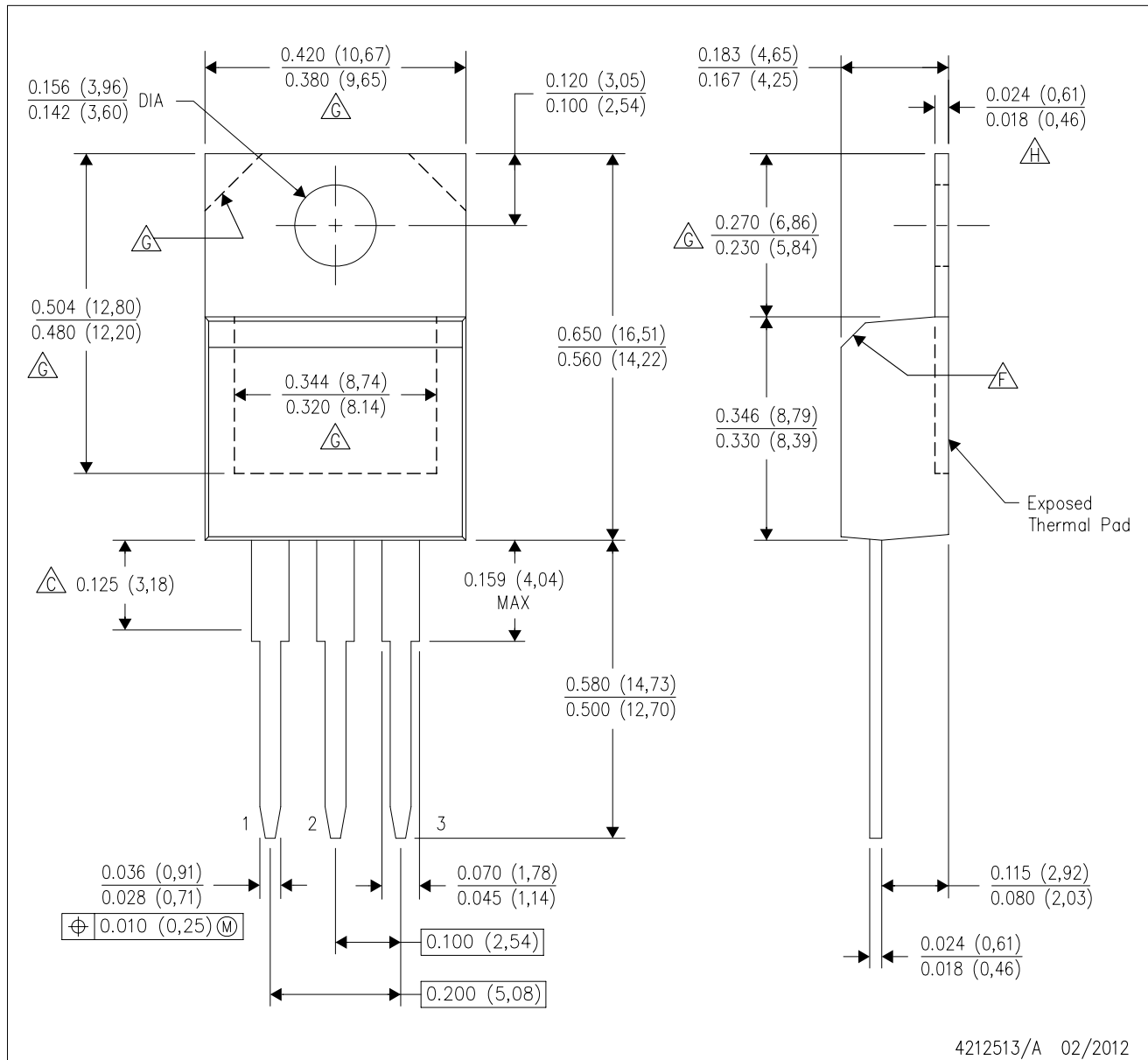

- NOTES:
- A. All linear dimensions are in inches (millimeters).
 - B. This drawing is subject to change without notice.
 - C. Lead dimensions are not controlled within this area.
 - D. All lead dimensions apply before solder dip.
 - E. The center lead is in electrical contact with the mounting tab.
 - F. The chamfer is optional.
 - G. Thermal pad contour optional within these dimensions.
 - H. Falls within JEDEC TO-220 variation AB, except minimum tab thickness.

IMPORTANT NOTICE

Texas Instruments Incorporated and its subsidiaries (TI) reserve the right to make corrections, enhancements, improvements and other changes to its semiconductor products and services per JESD46, latest issue, and to discontinue any product or service per JESD48, latest issue. Buyers should obtain the latest relevant information before placing orders and should verify that such information is current and complete. All semiconductor products (also referred to herein as "components") are sold subject to TI's terms and conditions of sale supplied at the time of order acknowledgment.

TI warrants performance of its components to the specifications applicable at the time of sale, in accordance with the warranty in TI's terms and conditions of sale of semiconductor products. Testing and other quality control techniques are used to the extent TI deems necessary to support this warranty. Except where mandated by applicable law, testing of all parameters of each component is not necessarily performed.

TI assumes no liability for applications assistance or the design of Buyers' products. Buyers are responsible for their products and applications using TI components. To minimize the risks associated with Buyers' products and applications, Buyers should provide adequate design and operating safeguards.

TI does not warrant or represent that any license, either express or implied, is granted under any patent right, copyright, mask work right, or other intellectual property right relating to any combination, machine, or process in which TI components or services are used. Information published by TI regarding third-party products or services does not constitute a license to use such products or services or a warranty or endorsement thereof. Use of such information may require a license from a third party under the patents or other intellectual property of the third party, or a license from TI under the patents or other intellectual property of TI.

Reproduction of significant portions of TI information in TI data books or data sheets is permissible only if reproduction is without alteration and is accompanied by all associated warranties, conditions, limitations, and notices. TI is not responsible or liable for such altered documentation. Information of third parties may be subject to additional restrictions.

Resale of TI components or services with statements different from or beyond the parameters stated by TI for that component or service voids all express and any implied warranties for the associated TI component or service and is an unfair and deceptive business practice. TI is not responsible or liable for any such statements.

Buyer acknowledges and agrees that it is solely responsible for compliance with all legal, regulatory and safety-related requirements concerning its products, and any use of TI components in its applications, notwithstanding any applications-related information or support that may be provided by TI. Buyer represents and agrees that it has all the necessary expertise to create and implement safeguards which anticipate dangerous consequences of failures, monitor failures and their consequences, lessen the likelihood of failures that might cause harm and take appropriate remedial actions. Buyer will fully indemnify TI and its representatives against any damages arising out of the use of any TI components in safety-critical applications.

In some cases, TI components may be promoted specifically to facilitate safety-related applications. With such components, TI's goal is to help enable customers to design and create their own end-product solutions that meet applicable functional safety standards and requirements. Nonetheless, such components are subject to these terms.

No TI components are authorized for use in FDA Class III (or similar life-critical medical equipment) unless authorized officers of the parties have executed a special agreement specifically governing such use.

Only those TI components which TI has specifically designated as military grade or "enhanced plastic" are designed and intended for use in military/aerospace applications or environments. Buyer acknowledges and agrees that any military or aerospace use of TI components which have **not** been so designated is solely at the Buyer's risk, and that Buyer is solely responsible for compliance with all legal and regulatory requirements in connection with such use.

TI has specifically designated certain components as meeting ISO/TS16949 requirements, mainly for automotive use. In any case of use of non-designated products, TI will not be responsible for any failure to meet ISO/TS16949.

Products

Audio	www.ti.com/audio
Amplifiers	amplifier.ti.com
Data Converters	dataconverter.ti.com
DLP® Products	www.dlp.com
DSP	dsp.ti.com
Clocks and Timers	www.ti.com/clocks
Interface	interface.ti.com
Logic	logic.ti.com
Power Mgmt	power.ti.com
Microcontrollers	microcontroller.ti.com
RFID	www.ti-rfid.com
OMAP Applications Processors	www.ti.com/omap
Wireless Connectivity	www.ti.com/wirelessconnectivity

Applications

Automotive and Transportation	www.ti.com/automotive
Communications and Telecom	www.ti.com/communications
Computers and Peripherals	www.ti.com/computers
Consumer Electronics	www.ti.com/consumer-apps
Energy and Lighting	www.ti.com/energy
Industrial	www.ti.com/industrial
Medical	www.ti.com/medical
Security	www.ti.com/security
Space, Avionics and Defense	www.ti.com/space-avionics-defense
Video and Imaging	www.ti.com/video

TI E2E Community

e2e.ti.com