

# LM2506 Low Power Mobile Pixel Link (MPL) Level 0, 18-bit RGB Display Interface Serializer and Deserializer

Check for Samples: [LM2506](#)

## FEATURES

- RGB Display Interface Support up to 800 x 300 ½SVGA Formats
- MPL-Level 0 Physical Layer using Two Data and One Clock Signal
- Low Power Consumption
- Pinout Mirroring Enables Straight Through Layout with Minimal vias
- Level Translation between Host and Display
- Auto Power Down on STOP PCLK
- Link Power Down Mode Reduces Quiescent Power Under < 10  $\mu$ A
- 1.74V to 2.0V Core / Analog Supply Voltage Range
- 1.74V to 3.0V I/O Supply Voltage Range
- –30C to 85C Operating Temperature Range

## SYSTEM BENEFITS

- Small Interface
- Low Power
- Low EMI
- Intrinsic Level Translation

## DESCRIPTION

The LM2506 device adapts RGB style display interfaces to the Mobile Pixel Link (MPL) Level zero serial link. The LM2506 supports one RGB display at up to 18-bit color depth and 800 X 300 pixels (over 216 Mbps and 13.2 MHz PCLK) is supported. A mode pin configures the device as a Serializer (SER) or Deserializer (DES) so the same chip can be used on both sides of the interface.

The interconnect is reduced from 22 signals to only 3 active signals with the LM2506 chipset easing flex interconnect design, size constraints and cost.

The LM2506 in SER mode resides beside an application, graphics or baseband processor and translates a parallel bus from LVCMOS levels to serial Mobile Pixel Link levels for transmission over a flex cable (or coax) and PCB traces to the DES located near the display module.

When the Power\_Down (PD\*) input is asserted on the SER, the MDn and MC line drivers are powered down to save current. The DES can be controlled by a separate Power\_Down input or via a signal from the SER (PD<sub>OUT</sub>\*).

The LM2506 implements the physical layer of the MPL Level 0 Standard (MPL-0) and a 150  $\mu$ A I<sub>B</sub> current (Class 0).

## Typical Application Diagram - Bridge Chips

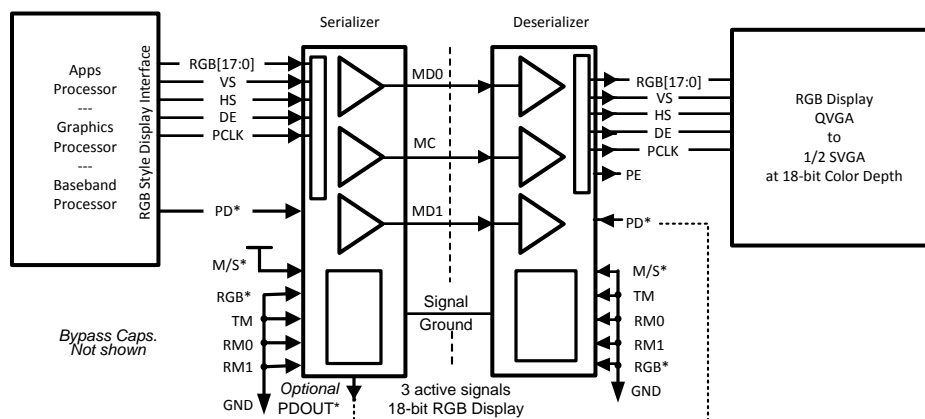

Please be aware that an important notice concerning availability, standard warranty, and use in critical applications of Texas Instruments semiconductor products and disclaimers thereto appears at the end of this data sheet.

All trademarks are the property of their respective owners.

### Typical Application Diagram - RGB Mode to Display Driver

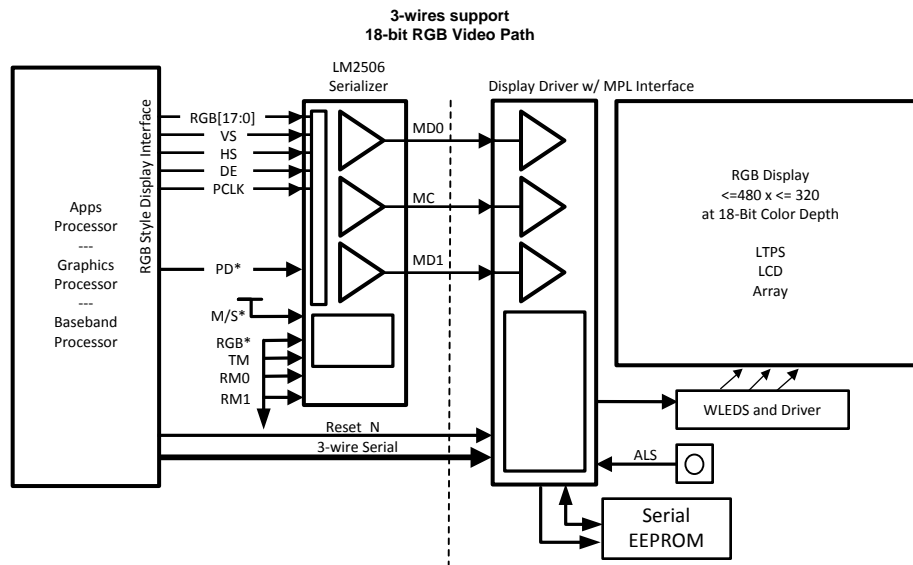

### Pin Descriptions - RGB Mode

Pin Name	No. of Pins	I/O, Type	Description	
			RGB Serializer	RGB Deserializer
<b>MPL SERIAL BUS PINS</b>				
MD[1:0]	2	IO, MPL	MPL Data Line Driver	MPL Data Receiver
MC	1	IO, MPL	MPL Clock Line Driver	MPL Clock Receiver
V <sub>SSA</sub>		Ground	MPL Ground - see Power/Ground Pins	
<b>CONFIGURATION/PARALLEL BUS PINS</b>				
RGB*	1	I, LVCMOS	RGB Mode Input <b>Tie Low</b>	
M/S*	1	I, LVCMOS	Tie High for Serializer (Master)	Tie Low for Deserializer (Slave)
TM	1	I, LVCMOS	Test Mode control input <b>Tie Low (normal mode)</b>	
RM0	1	I, LVCMOS	RGB Mode control input zero <b>Tie Low</b>	
RM1	1	I, LVCMOS	RGB Mode control input one <b>Tie Low</b>	
<b>CLOCK / POWER DOWN SIGNALS</b>				
PCLK	1	IO, LVCMOS	PCLK input	PCLK output
PD <sub>OUT</sub> *	1	O, LVCMOS	Power Down Output, L = device in Power Down H = Device active.	
PD*	1	I, LVCMOS	Power Down input, L = Powered down (sleep mode) H = active mode	
<b>PARALLEL INTERFACE SIGNALS</b>				
D[17:0]	18	IO, LVCMOS	RGB Data Bus inputs	RGB Data Bus outputs
VS	1	IO, LVCMOS	Vertical Sync. Input	Vertical Sync. Output
HS	1	IO, LVCMOS	Horizontal Sync. Input	Horizontal Sync. Output

**Pin Descriptions - RGB Mode (continued)**

Pin Name	No. of Pins	I/O, Type	Description	
			RGB Serializer	RGB Deserializer
DE	1	IO, LVCMOS	Data Enable Input	Data Enable Output
PE	1	O, LVCMOS	NA	Parity Error Output
<b>POWER/GROUND PINS</b>				
V <sub>DDA</sub>	1	Power	Power Supply Pin for the SER PLL and MPL Interface. 1.74V to 2.0V	
V <sub>SSA</sub>	1	Ground	Ground Pin for the MPL Interface, and analog circuitry.	
V <sub>DDcore</sub>	1	Power	Power Supply Pin for the digital core. 1.74V to 2.0V	
V <sub>SScore</sub>	1	Ground	Ground Pin for the digital core.	
V <sub>DDIO</sub>	2	Power	Power Supply Pin for the parallel interface I/Os. 1.74V to 3.0V	
V <sub>SSIO</sub>	2	Ground	Ground Pin for the parallel interface I/Os.	
V <sub>bulk</sub>	9		Connect to Ground - csBGA Package	
DAP	1		Connect to Ground - WQFN Package	



These devices have limited built-in ESD protection. The leads should be shorted together or the device placed in conductive foam during storage or handling to prevent electrostatic damage to the MOS gates.

**ABSOLUTE MAXIMUM RATINGS<sup>(1)(2)</sup>**

Supply Voltage (V <sub>DDA</sub> )		-0.3V to +2.2V
Supply Voltage (V <sub>DD</sub> )		-0.3V to +2.2V
Supply Voltage (V <sub>DDIO</sub> )		-0.3V to +3.6V
LVCMOS Input/Output Voltage		-0.3V to (V <sub>DDIO</sub> + 0.3V)
MPL Input/Output Voltage		-0.3V to V <sub>DDA</sub>
Junction Temperature		+150°C
Storage Temperature		-65°C to +150°C
Lead Temperature Soldering, 40 Seconds		+260°C
ESD Ratings:	HBM, 1.5 kΩ, 100 pF	≥±2 kV
	EIAJ, 0Ω, 200 pF	≥±200V
Maximum Package Power Dissipation Capacity at 25°C	NYC Package	1.8W
	Derate NYC Package above 25°C	15mW/°C
	RSB Package	1.8W
	Derate RSB Package above 25°C	15mW/°C

- (1) "Absolute Maximum Ratings" are those values beyond which the safety of the device cannot be specified. They are not meant to imply that the device should be operated at these limits. The tables of "Electrical Characteristics" specify conditions for device operation.
- (2) If Military/Aerospace specified devices are required, please contact the TI Sales Office/ Distributors for availability and specifications.

**RECOMMENDED OPERATING CONDITIONS**

		Min	Typ	Max	Units
Supply Voltage	V <sub>DDA</sub> to V <sub>SSA</sub> and V <sub>DDcore</sub> to V <sub>SScore</sub>	1.74	1.8	2.0	V
	V <sub>DDIO</sub> to V <sub>SSIO</sub>	1.74		3.0	V
PCLK Frequency		2		13.3	MHz
Ambient Temperature		-30	25	85	°C

## ELECTRICAL CHARACTERISTICS

Over recommended operating supply and temperature ranges unless otherwise specified. <sup>(1)</sup> <sup>(2)</sup>

Symbol	Parameter	Conditions		Min	Typ	Max	Units
<b>MPL</b>							
$I_{OLL}$	Logic Low Current (5X $I_B$ )			$3.67 I_B$	$5.0 I_B$	$6.33 I_B$	$\mu A$
$I_{OMS}$	Mid Scale Current <sup>(3)</sup> <sup>(4)</sup>			$2.1 I_B$	$3.0 I_B$	$3.9 I_B$	$\mu A$
$I_{OLH}$	Logic High Current (1X $I_B$ )			$0.7 I_B$	$1.0 I_B$	$1.4 I_B$	$\mu A$
$I_B$	Current Bias				150		$\mu A$
$I_{OFF}$	MPL Leakage Current	$V_{MPL} = 0.8V$		-2		+2	$\mu A$
<b>LVC MOS (1.74V to 3.0V Operation)</b>							
$V_{IH}$	Input Voltage High Level			$0.7 V_{DDIO}$		$V_{DDIO}$	V
$V_{IL}$	Input Voltage Low Level			GND		$0.3 V_{DDIO}$	V
$V_{HY}$	Input Hysteresis	$V_{DDIO} = 1.74V$			150		mV
		$V_{DDIO} = 3.0V$			200		mV
$I_{IH}$	Input Current High Level	Includes $I_{OZ}$	$V_{in} = V_{DDIO}$	-1	0	+1	$\mu A$
$I_{IL}$	Input Current Low Level		$V_{in} = GND$	-1	0	+1	$\mu A$
$V_{OH}$	Output Voltage High Level	$I_{OH} = -2 \text{ mA}$		$0.75 V_{DDIO}$		$V_{DDIO}$	V
$V_{OL}$	Output Voltage Low Level	$I_{OL} = 2 \text{ mA}$		$V_{SSIO}$		$0.2 V_{DDIO}$	V
<b>SUPPLY CURRENT</b>							
$I_{DD}$	Total Supply Current—Enabled Conditions: MC = 80 MHz, MD = 160 Mbps <sup>(5)</sup>	SER	$V_{DDIO}$		20	66	$\mu A$
			$V_{DD}/V_{DDA}$		5	12	mA
		DES	$V_{DDIO}$		4	10	mA
			$V_{DD}/V_{DDA}$		6	11	mA
	Supply Current—Enabled 1.8V <sup>(6)</sup>	SER	$V_{DDIO}$		10		$\mu A$
			$V_{DD}/V_{DDA}$		4.7		mA
DES		$V_{DDIO}$		2.3		mA	
		$V_{DD}/V_{DDA}$		6.2		mA	
$I_{DDZ}$	Supply Current—Disable $T_A = 25^\circ C$ Power Down Modes	SER PD* = L	$V_{DDIO}$		<1	2	$\mu A$
			$V_{DD}/V_{DDA}$		<1	2.2	$\mu A$
		SER Stop Clock	$V_{DDIO}$		<1	2	$\mu A$
			$V_{DD}/V_{DDA}$		<1	2.2	$\mu A$
		DES PD* = L	$V_{DDIO}$		<1	2	$\mu A$
			$V_{DD}/V_{DDA}$		<1	2.2	$\mu A$
PD	Power Dissipation	RGB <sup>(6)</sup>	SER		8.5		mW
			DES		15.3		mW

(1) Typical values are given for  $V_{DDIO} = 1.8V$  and  $V_{DD} = V_{DDA} = 1.8V$  and  $T_A = 25^\circ C$ .

(2) Current into a device pin is defined as positive. Current out of device pins is defined as negative. Voltages are referenced to Ground unless otherwise specified.

(3) MPL Current Threshold is set to be  $3XI_B$  by the MPL start up Sequence - this is a functional specification only.

(4) This is a functional parameter and is specified by design or characterization.

(5) Total Supply Current Conditions: RGB Mode, worst case data pattern, 13.3MHz PCLK, DES  $C_L = 15pF$ , TYP  $V_{DDIO} = V_{DDA} = V_{DDcore} = 1.8V$ , MAX  $V_{DDIO} = 3.0V$ , MAX  $V_{DDA} = V_{DDcore} = 2.0V$ .

(6) Supply Current Conditions: RGB Mode, PRBS case data pattern, 13.3MHz PCLK, DES  $C_L = 15pF$ , TYP  $V_{DDIO} = V_{DDA} = V_{DDcore} = 1.8V$ .

## SWITCHING CHARACTERISTICS

Over recommended operating supply and temperature ranges unless otherwise specified.<sup>(1)</sup>

Symbol	Parameter	Conditions	Min	Typ	Max	Units
<b>PARALLEL BUS TIMING</b>						
$t_{SET}$	Set Up Time	RGB Mode Inputs <a href="#">Figure 11</a>	5			ns
$t_{HOLD}$	Hold Time		5			ns
$t_{RISE}$	Rise Time	PCLK Output $C_L = 15$ pF, <a href="#">Figure 2</a>	$V_{DDIO} = 1.74V$	7	12	ns
			$V_{DDIO} = 3.0V$	3	7	ns
$t_{FALL}$	Fall Time		$V_{DDIO} = 1.74V$	7	11	ns
			$V_{DDIO} = 3.0V$	2	6	ns
<b>SERIAL BUS TIMING</b>						
$t_{DVBC}$	Serial Data Valid before Clock (Set Time)	DES Input <a href="#">Figure 1</a>	MC = 80MHz <sup>(2)</sup>	1.5		ns
$t_{DVAC}$	Serial Data Valid after Clock (Hold Time)			1.5		ns
<b>POWER UP TIMING</b>						
$t_0$	SER PLL Lock Counter			4,096		PCLK cycles
$t_1$	MC Pulse Width Low			180		MC cycles
$t_2$	MC Pulse Width High			180		MC cycles
$t_3$	MC H-L to Active State			180		MC cycles
$t_{PZclk}$	Enable Time - Clock Start RGB Mode	CLK to PDout*	See <a href="#">Figure 4</a>	7		PCLK cycles
<b>MPL POWER OFF TIMING</b>						
$t_{PAZ}$	Disable Time to Power Down	See <sup>(3)</sup>			2	ms
$t_{PXZclk}$	Disable Time - Clock Stop	PCLK to PD <sub>OUT</sub> * <a href="#">Figure 3</a>		7		PCLK cycles

(1) Typical values are given for  $V_{DDIO} = 1.8V$  and  $V_{DD} = V_{DDA} = 1.8V$  and  $T_A = 25^\circ C$ .

(2) This is a functional parameter and is specified by design or characterization.

(3) Specified functionally by the  $I_{DDZ}$  parameter. See also [Figure 8](#).

## RECOMMENDED INPUT TIMING REQUIREMENTS

Over recommended operating supply and temperature ranges unless otherwise specified.<sup>(1)</sup>

Symbol	Parameter	Conditions	Min	Typ	Max	Units
<b>SER PIXEL CLOCK (PCLK)</b>						
$f$	Pixel Clock Frequency		2		13.3	MHz
$t_{CP}$	Pixel Clock Period		75.2		500	ns
$PCLK_{DC}$	Pixel Clock Duty Cycle		30	50	70	%
$t_T$	Transition Time	See <sup>(2)</sup>	2			ns
$t_{STOPpclk}$	Pclock Stop Gap		300			ns

(1) Typical values are given for  $V_{DDIO} = 1.8V$  and  $V_{DD} = V_{DDA} = 1.8V$  and  $T_A = 25^\circ C$ .

(2) Maximum transition time is a function of clock rate and should be less than 30% of the clock period to preserve signal quality.

**TIMING DIAGRAMS**

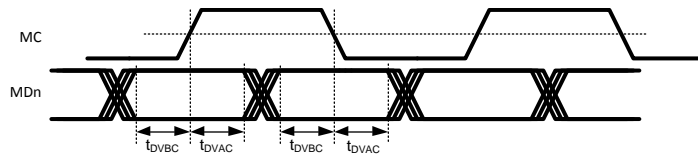

**Figure 1. Serial Data Valid—DES Input Set and Hold Time**

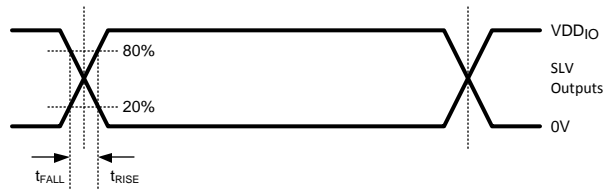

**Figure 2. DES Output Rise and Fall Time (PCLK)**

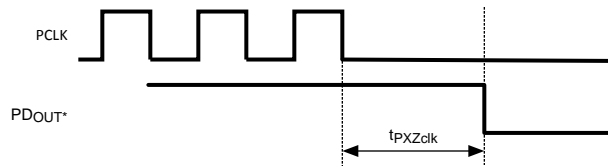

**Figure 3. Stop Clock Power Down (SER)**

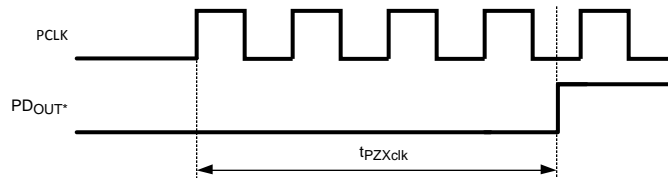

**Figure 4. Stop Clock Power Up (SER)**

## FUNCTIONAL DESCRIPTION

### BUS OVERVIEW

The LM2506 is a dual link SER/DES configurable part that supports an 18-bit RGB Display interface. The MPL physical layer is purpose-built for an extremely low power and low EMI data transmission while requiring the fewest number of signal lines. No external line components are required, as termination is provided internal to the MPL receiver. A maximum raw throughput of 320 Mbps (raw) is possible with this chipset. When the protocol overhead is taken into account, a maximum data throughput of 240 Mbps is possible. The MPL interface is designed for use with common 50Ω to 100Ω lines using standard materials and connectors. Lines may be microstrip or stripline construction. Total length of the interconnect is expected to be less than 20cm.

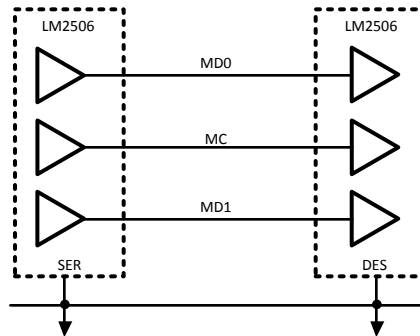

Figure 5. MPL Point-to-Point Bus

### SERIAL BUS TIMING

Data valid is relative to both edges for a RGB transaction as shown in Figure 6. Data valid is specified as: Data Valid before Clock, Data Valid after Clock, and Skew between data lines should be less than 500ps.

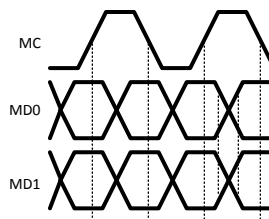

Figure 6. Dual Link Timing (WRITE)

### SERIAL BUS PHASES

There are three bus phases on the MPL serial bus. These are determined by the state of the MC and MD lines. The MPL bus phases are shown in Table 1.

The LM2506 supports MPL Level 0 Enhanced Protocol with a Class 0 PHY.

**Table 1. Link Phases<sup>(1)</sup>**

Name	MC State	MDn State	Phase Description	Pre-Phase	Post-Phase
OFF (O)	0	0	Link is Off	A, I or LU	LU
ACTIVE (A)	A	X	Data Out	LU, A, or I	A, I, or O
LINK-UP (LU)	H	-	SER initiated Link-Up	O	A, I, or O

**(1) Notes on MC/MD Line State:**

0 = no current (off)

L = Logic Low—The higher level of current on the MC and MD lines

H = Logic High—The lower level of current on the MC and MD lines

X = Low or High

A = Active Clock

**SERIAL BUS START UP TIMING**

In the Serial Bus OFF phase, SER transmitters for MD0, MD1 and MC are turned off such that zero current flows over the MPL lines. In addition, both the SER and the DES are internally held in a low power state. When the PD\* input pins are de-asserted (driven High) the SER enables its PLL and waits for enough time to pass for its PLL to lock. After the SER's PLL is locked ( $t_0 = 4,096$  PCLK Cycles), the SER will perform an MPL start up sequence. The DES will power up and await the start up sequence from the SER once its PD\* input is driven High.

The MPL start up sequence gives the DES an opportunity to optimize the current sources in its receivers to maximize noise margins. The SER begins the sequence by driving the MC line logically Low for 180 MC cycles ( $t_1$ ). At this point, the DES's receiver samples the MC current flow and adjusts itself to interpret that amount of current as a logical Low. Next the SER drives the MC line logically HIGH for 180 MC cycles ( $t_2$ ). The optimized current configuration is held as long as the MPL remains active. Next, the SER drives both the MC and the MD lines to a logical Low for another 180 MC cycles ( $t_3$ ), after which it begins to toggle the MC line at 6X the PCLK rate. The SER will continue to toggle the MC line as long as its PD\* pin remains de-asserted (High). At this point, video data is streaming to the DES.

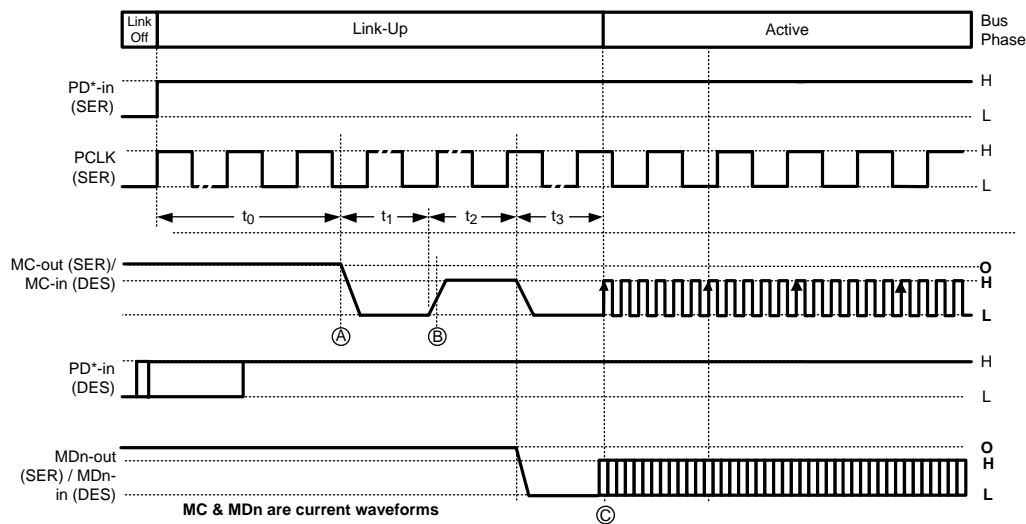
**Figure 7. Bus Power Up Timing**

Once power is applied and stable, the PCLK should be applied to the SER. Next the PD\* inputs are driven High to enable the SER and DES. The DES PD\* input may be driven High first, at the same time, or slightly later than the SER's PD\* input. The SER's PLL locks to the PCLK and the SER drives the MC line to the 5I (Logic Low) state at point "A" for  $t_1$ . Next the SER drives the MC line to the 1I (Logic High) state for  $t_2$ . On the  $T_1$  to  $t_2$  transition - point "B", the DES calibrates its current to that of the SER to maximize noise margins. Next the SER drives the MC and MD lines to the 5I (logic Low) state for  $t_3$ . At point "C", video data is now sampled and streamed to the DES.

## OFF PHASE

In the OFF phase, both SER and DES MPL transmitters are turned off with zero current flowing on the MC and MDn lines. Figure 8 shows the transition of the MPL bus into the OFF phase. If an MPL line is driven to a logical Low (high current) when the OFF phase is entered it may temporarily pass through as a logical High (low current) before reaching the zero line current state.

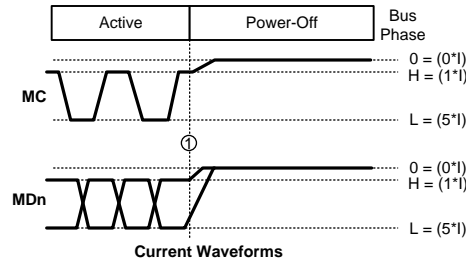

Figure 8. Bus Power Down Timing

## RGB VIDEO INTERFACE

The LM2506 is transparent to data format and control signal timing. Each PCLK, data inputs, HS, VS and DE are sampled. A PCLK by PCLK representation of these signals is duplicated on the opposite device after being transferred across the MPL Level-0 interface.

The LM2506 uses a multiple range PLL and an on-chip multiplier to accommodate a wide range of display formats. QVGA to ½SVGA can be supported within the 2 MHz to 13.3 MHz PCLK input range.

### Pixel Bandwidth = H. X V. X Color Depth X Frames

Pixel bandwidth is equal to display resolution times color depth times frame rate.

### Net Bandwidth = (Pixel BW)(24/18)(1.0 + % Blanking)

Net bandwidth is equal to the pixel bandwidth times the overhead times the blanking overhead.

### PCLK Rate = Net Bandwidth / 24

The PCLK rate is equal to the net bandwidth divided by the total number of bits.

Format	Hor. Pixels	Ver. Pixels	Color Depth	Frames fps	Pixel BW Mbps	Percent Blanking	Net BW Mbps	PCLK rate MHz
½SVGA	800	300	18	50	216	10	316	13.2
¾VGA	640	320	16	55	180	10	265	11
½VGA	320	480	18	55	152	10	223	9.3
QVGA	320	240	18	55	76	20	122	5.1

### Other RGB Color Depths

When transporting color depth below 18-bit, the 18-bit protocol can be used by offsetting the color data. The LSBs of the RGB are not used and data is offset toward the upper (MSB) end of the bit fields. Unused inputs should be tied off.

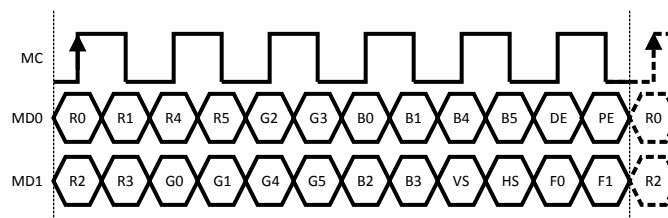
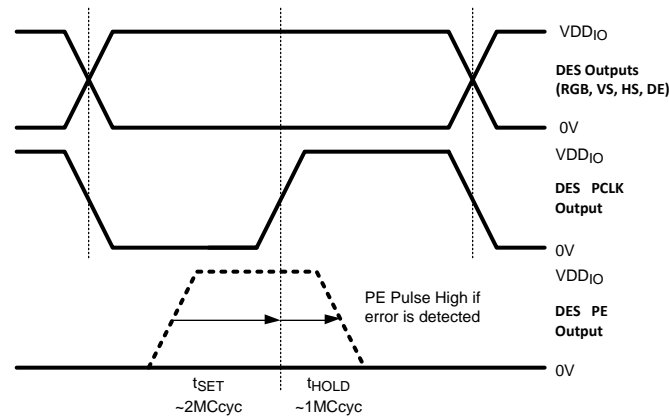

Figure 9. 18-bit RGB Display Mode Transaction

## Parity Error Output

Parity Status is output as a pulse on the Parity Error (PE) output pin (DES) whenever there is a parity error. These pulses could be counted or used by various diagnostic equipment. PE is a high going pulse that is 3 MC cycles long for each frame containing an error. The PCLK output can be used to sample the PE bit. SET time is nominally 2 MC cycles and a HOLD time of 1 MC cycle. The serial PE bit is Odd Parity and is based on the RGB, and Control (VS, HS, DE) bits only. See [Figure 10](#).



**Figure 10. PE Output Timing**

## SYNCHRONIZATION DETECT AND RECOVERY

If a data error or clock slip error occurs over the MPL link, the LM2506 can detect this condition and recover from it. The method chosen is a data transparent method, and has very little overhead because it does not use a data expansion coding method. For the 18-bit color transaction (or frame), it uses two bits that are already required in the 6-MC cycle transaction. Since double-edge clocking is used with two data signals, adding one clock cycle to the transaction actually adds four bits. One of these bits is absolutely required - data enable - thus the others are allocated to Parity and the frame sequence (F[1:0]). Therefore total overhead for each pixel is 3/24 or 12.5% in 18-bit RGB mode.

## HOST SIDE FUNCTION

The LM2506 in serializer mode simply increments the two bit field F[1:0] on every pixel or frame transmitted. Therefore every four frames, the pattern will repeat. It is very unlikely that this pattern would be found within the payload data, and if it were found, the probability that it would repeat for many frames becomes infinitely small.

## DISPLAY SIDE FUNCTION

The LM2506 in deserializer mode, upon a normal power up sequence, starts in the proper synchronization. It looks for the incrementing pattern for N (N = 4 or 8) pixels (frames) and finding it, starts to output the pixel gray scale data and timing signals.

If a random bit error occurs in the F[1:0] field, the hysteresis counter decrements by one, but the chip continues to output data normally. The next frame will likely recover, incrementing the hysteresis counter back to the maximum and things will continue normally. Likewise if a random bit error occurs in the gray scale data, it only effects that bit and transmission will continue normally on the next frame (pixel). The worst case data bit error would cause a one pixel wide glitch in the HS, VS or DE signals. This would likely cause a visible jump in the display, but it would recover in a maximum of one display frame time. (typically under 20mS)

If however, a clock slip or error occurs, the next N frames will be bad and the F[1:0] field will not be detected properly for each frame after the clock error. In this case, the hysteresis counter will decrement to zero quickly (again where N=4 or 8 pixels). This action shuts down the output data (output PCLK held Low), and initiates a search function for the incrementing sequence.

### Detecting the Incrementing Sequence

Acquiring synchronization from a random position requires looking only at the MD1 line, as this line contains the incrementing sequence F[1:0]. This is done by examining six two-bit pairs and comparing each pair to an incrementing sequence. A snapshot of the data is first taken and loaded into six two-bit adders. The adders increment by one and then compare the same bit positions in the next 12-bits. If a match is found a flag is set for that bit pair. This same procedure is followed until there is only one flag set. After only one flag is set, the synchronization is tested for the full count of the hysteresis counter (4 or 8 pixels) and then a valid synchronization is declared and pixel data and strobes are again output to the display.

In the best case, this parallel method of detecting sync is very fast. If only one flag exists on the first frame tested, then resynchronization can occur in as little as 6 pixel times (assuming NNE = no new errors). If however, random data emulates an incrementing sequence for several pixels of time, the process can take longer. It is data dependant.

It is important to note that a pathological case exists, as it does for most pattern detection methods, where the data can forever emulate this incrementing sequence, when in fact the true F[1:0] is not detected. This F'[1:0] (F prime) may occur for several pixels, but becomes linearly less probable as more and more data passes through the system.

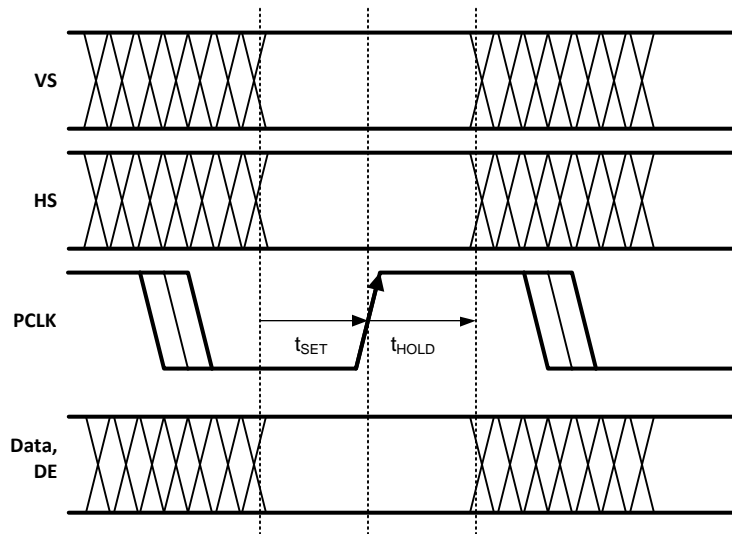

Figure 11. Serializer Mode Input Timing for RGB Interface

Table 2. Serializer Input Timing Parameters for RGB Interface<sup>(1)(2)</sup>

Sym.	Parameter	Min	Typ	Max	Units
$t_{SET}$	Data (RGB, DE, VS or HS) to PCLK - Set Time	5			ns
$t_{HOLD}$	PCLK to Data (RGB, DE, VS or HS) - Hold Time	5			ns

(1) Signal rise and fall times are equal to or less than 20ns

(2) Measurement of signal timing is made using 0.3 x VDDIO for the low state and 0.7 x VDDIO for the high state.

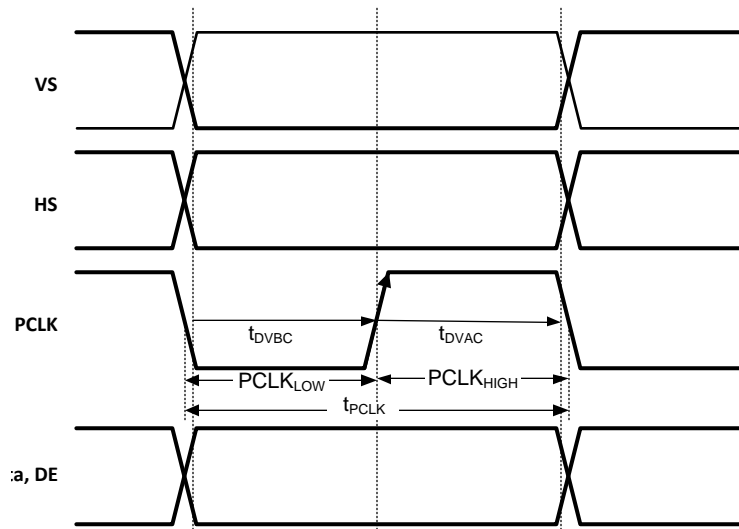

**Figure 12. Deserializer Mode Output Timing for RGB Interface**

**Table 3. Deserializer Output Timing Parameters for RGB Interface**

Sym.	Parameter		Min	Typ	Max	Units
$t_{DVBC}$	Data Valid before PCLK (rise) (1)	PCLK = 2 MHz	230			ns
		PCLK = 13.3 MHz	30			ns
$t_{DVAC}$	Data Valid after PCLK (rise) (1)	PCLK = 2 MHz	230			ns
		PCLK = 13.3 MHz	30			ns
$t_{PCLK}$	Pixel Clock Period		75.2		500	ns
PCLK <sub>LOW</sub>	Pixel Clock Low			50		%
PCLK <sub>HIGH</sub>	Pixel Clock High			50		%

(1) This is a functional parameter and is specified by design or characterization.

## LM2506 FEATURES AND OPERATION

### POWER SUPPLIES

The  $V_{DDcore}$  and  $V_{DDA}$  (MPL and PLL) must be connected to the same potential between 1.74V and 2.0V.  $V_{DDIO}$  powers the logic interface and may be powered between 1.74 and 3.0V to be compatible with a wide range of host and target devices. **On this device,  $V_{DDIO}$  should be powered up before  $V_{DDcore}/V_{DDA}$  or at the same time as  $V_{DDcore}/V_{DDA}$  for proper device configuration.**

### BYPASS RECOMMENDATIONS

Bypass capacitors should be placed near the power supply pins of the device. Use high frequency ceramic (surface mount recommended) 0.1  $\mu$ F capacitors. A 2.2 to 4.7  $\mu$ F Tantalum capacitor is recommended near the SER  $V_{DDA}$  pin for PLL bypass. Connect bypass capacitors with wide traces and use dual or larger via to reduce resistance and inductance of the feeds. Utilizing a thin spacing between power and ground planes will provide good high frequency bypass above the frequency range where most typical surface mount capacitors are less effective. To gain the maximum benefit from this, low inductance feed points are important. Also, adjacent signal layers can be filled to create additional capacitance. Minimize loops in the ground returns also for improved signal fidelity and lowest emissions.

### UNUSED/OPEN PINS

Unused inputs must be tied to the proper input level—do not float them. Unused outputs should be left open to minimize power dissipation.

## PHASE-LOCKED LOOP

When the LM2506 is configured as a RGB Serializer, a PLL is enabled to generate the serial link clock. The Phase-locked loop system generates the serial data clock at 6X of the input clock. The MC rate must be between 12 and 80 MHz (PCLKs from 2 to 13.3 MHz).

## MASTER(SER)/SLAVE(DES) SELECTION

The M/S\* pin is used to configure the device as either a SER or DES device. When the M/S\* pin is a Logic High, the Serializer (SER) configuration is selected. The Driver block is enabled for the MC line, and the MD lines. When the M/S\* pin is a Logic Low, the Deserializer (DES) configuration is selected. The Receiver block is enabled for the MC line, and the MD lines.

## POWER DOWN/OFF CONFIGURATION / OPTIONS AND CLOCK STOP

Power Up Operation - Upon the application of power to the LM2506, devices configured as a DES activate all outputs. Outputs are held in deasserted states, with all zeros on the data busses until valid data is received from the SER. If PD\* is asserted (Low) prior to the application of power, then the part remains in its power down state.

On both the SER and the DES, the PD\* pin resets the logic. **The PD\* pins should be held low until the power supply has ramped up and is stable and within specifications.**

Power Down and the use of the PD\* Input - When the PD\* signal is asserted low, the entire chip regardless of mode, powers down. A Low on the PD\* input pin will power down the entire device and turn off the line current to MD0, MD1, and MC. In this state the following outputs are driven to:

### SER:

PD<sub>OUT</sub> = Low

### DES:

DATAn = PCLK = Low,

VS = HS = DE = PE = Low

Multiple configurations for PowerDown are possible with the chipset. These depend on the operating mode and configuration chosen. Two possible applications are shown in Figure 13. RGB Modes are shown in (A) and (B). "A" provides PD\* input pins on both devices, this may be common or separate. In (B), the SER is controlled by the PCLK STOP feature and a PDOUT\* pin is provided to control the DES. When using the SER PD<sub>OUT</sub>\* mode, the V<sub>DDIO</sub> rails of the devices should be the same to meet the PD\* input thresholds of the DES.

The LM2506 provides a PCLK STOP feature on the SER device. Gating of the pixel clock signal can be used to generate a control signal for the SER to Power down or start up. When a loss of pixel clock is detected (PLL out of lock), the SER PD<sub>OUT</sub>\* pin is driven Low and the SER powers down. When a PCLK is reapplied, the SER powers up, and the PLL locks to the incoming clock signal. After 4,096 cycles (t<sub>0</sub>), the SER MPL outputs are enabled and the DES is calibrated. Once this is complete (t<sub>1</sub> + t<sub>2</sub> + t<sub>3</sub>), data transmission can occur. See Figure 3 and Figure 4. The stopping of the pixel clock should be done cleanly. Floating of the PCLK input pin is not recommended.

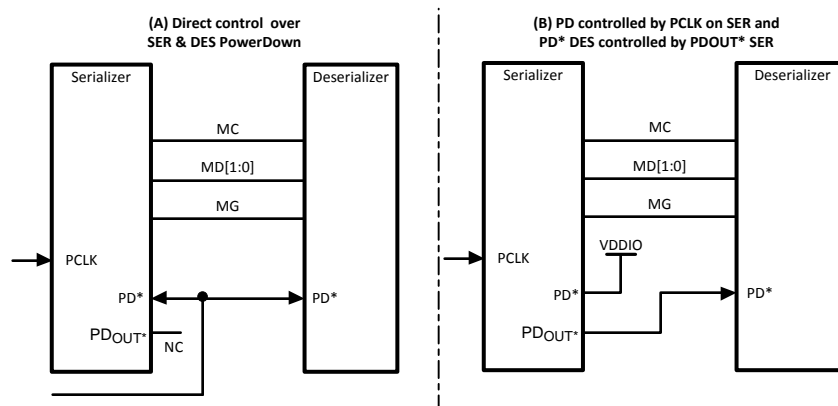

Figure 13. Power Down Control Options

## APPLICATION INFORMATION

### SYSTEM CONSIDERATIONS

When employing the MPL SER/DES chipset in place of a parallel bus, a few system considerations must be taken into account. VDDIO levels of the Host and SER must be compatible. VDDIO levels of the DES and the Display must be compatible. The LM2506 only supports **rising** edge clocking, both the Host and Display must be compatible with this.

### MPL SWAP FEATURE

The LM2506 provides a swap function of MPL MD lines depending upon the state of the M/S\* pin. This facilitates a straight through MPL interface design eliminating the needs for via and crossovers as shown on [Figure 14](#). The parallel bus pins are also swapped to facilitate a flow through orientation of parallel bus signals.

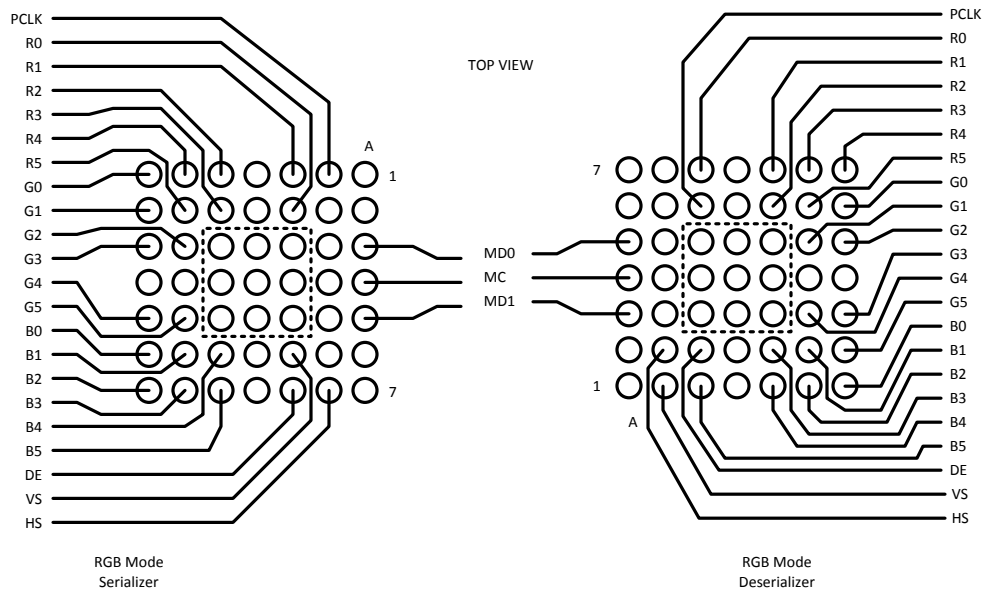

**Figure 14. MPL Interface Layout**

### Power and Ground - Bumped Package

Power and ground bump assignments are shown in [Figure 15](#). The nine center balls must be connected ground on the PCB for the csBGA package. See also, TI's Application Note AN-1126 ([SNOA021](#)), Ball Grid Array, for information on land pattern recommendations and escape routing guidelines.

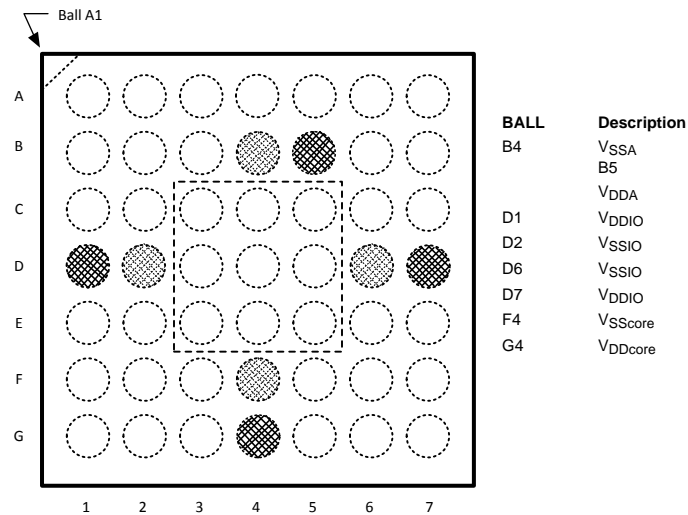

Figure 15. LM2506 PWR ( $V_{DD}$ ) and GND ( $V_{SS}$ ) Bumps (TOP VIEW)

### FLEX CIRCUIT RECOMMENDATIONS

The three MPL lines should generally run together to minimize any trace length differences (skew). For impedance control and also noise isolation (crosstalk), guard ground traces are recommended in between the signals. Commonly a Ground-Signal-Ground (GSGSGSG) layout is used. Locate fast edge rate and large swing signals further away to also minimize any coupling (unwanted crosstalk). In a stacked flex interconnect, crosstalk also needs to be taken into account in the above and below layers (vertical direction). To minimize any coupling locate MPL traces next to a ground layer. Power rails also tend to generate less noise than LVCMOS so they are also good candidates for use as isolation and separation.

The interconnect from the SER to the DES typically acts like a transmission line. Thus impedance control and ground returns are an important part of system design. Impedance should be in the 50 to 100 Ohm nominal range for the LM2506. Testing has been done with cables ranging from 40 to 110 Ohms without error (BER Testing). To obtain the impedance, adjacent grounds are typically required (1 layer flex), or a ground shield / layer. Total interconnect length is intended to be in the 20cm range, however 30cm is possible at lower data rates. Skew should be less than 500ps to maximize timing margins.

### GROUNDING

While the LM2506 employs three separate types of ground pins, these are intended to be connected together to a common ground plane. The separate ground pins help to isolate switching currents from different sections of the integrated circuit (IC). Also required is a nearby signal return (ground) for the MPL signals. These should be provided next to the MPL signals, as that will create the smallest current loop area. The grounds are also useful for noise isolation and impedance control.

### PCB RECOMMENDATIONS

General guidelines for the PCB design:

- Floor plan – locate MPL SER near the connector to limit chance of cross talk to high speed serial signals.
- Route serial traces together, minimize the number of layer changes to reduce loading.
- Use ground lines as guards to minimize any noise coupling (specifies distance).
- Avoid parallel runs with fast edge, large LVCMOS swings.
- Also use a GSGSG pinout in connectors (Board to Board or ZIF).
- DES device - follow similar guidelines.
- Bypass the device with MLC surface mount devices and thinly separated power and ground planes with low inductance feeds.
- High current returns should have a separate path with a width proportional to the amount of current carried to minimize any resulting IR effects.

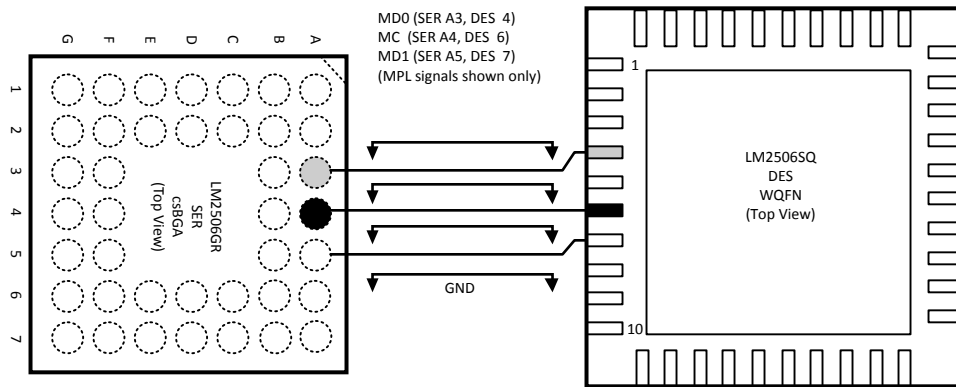

Figure 16. MPL Interface Layout

**CONNECTION DIAGRAM csBGA PACKAGE**

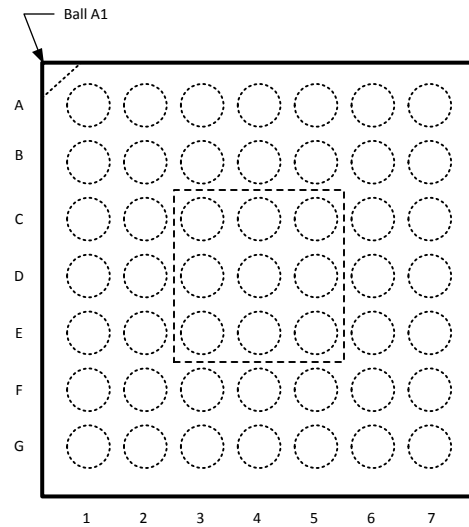

Figure 17. TOP VIEW  
(not to scale)

Table 4. RGB SER Pinout

SER	1	2	3	4	5	6	7
A	TM	RGB*	MD0	MC	MD1	RM1	M/S*
B	PCLK	PDOUT*	RM0	V <sub>SSA</sub>	V <sub>DDA</sub>	PD*	HS
C	R1	R0	V <sub>bulk</sub>	V <sub>bulk</sub>	V <sub>bulk</sub>	VS	DE
D	V <sub>DDIO</sub>	V <sub>SSIO</sub>	V <sub>bulk</sub>	V <sub>bulk</sub>	V <sub>bulk</sub>	V <sub>SSIO</sub>	V <sub>DDIO</sub>
E	R2	R3	V <sub>bulk</sub>	V <sub>bulk</sub>	V <sub>bulk</sub>	B4	B5
F	R4	R5	G2	V <sub>SScore</sub>	G5	B1	B3
G	G0	G1	G3	V <sub>DDcore</sub>	G4	B0	B2

Table 5. RGB DES Pinout

DES	1	2	3	4	5	6	7
A	TM	RGB*	MD1	MC	MD0	RM1	M/S*
B	VS	HS	RM0	V <sub>SSA</sub>	V <sub>DDA</sub>	PD*	PE
C	B5	DE	V <sub>bulk</sub>	V <sub>bulk</sub>	V <sub>bulk</sub>	PCLK	R0
D	V <sub>DDIO</sub>	V <sub>SSIO</sub>	V <sub>bulk</sub>	V <sub>bulk</sub>	V <sub>bulk</sub>	V <sub>SSIO</sub>	V <sub>DDIO</sub>
E	B4	B3	V <sub>bulk</sub>	V <sub>bulk</sub>	V <sub>bulk</sub>	R2	R1
F	B2	B1	G4	V <sub>SScore</sub>	G1	R5	R3
G	B0	G5	G3	V <sub>DDcore</sub>	G2	G0	R4

CONNECTION DIAGRAM - WQFN PACKAGE

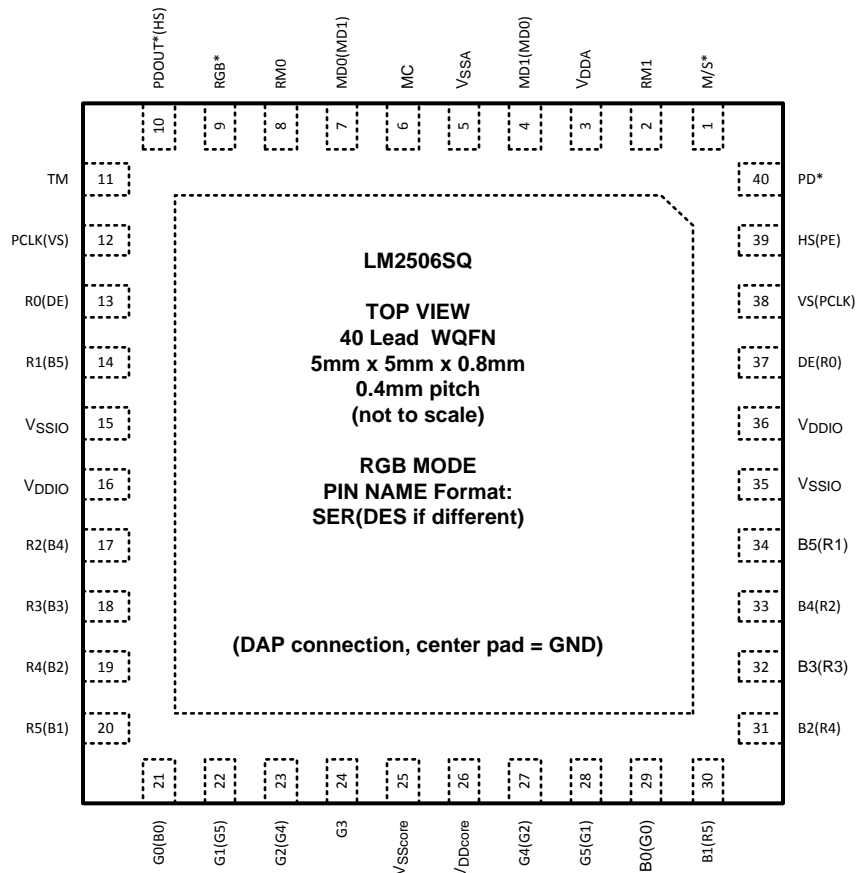

Figure 18. TOP VIEW — (not to scale)

**RGB Mode Pad Assignment<sup>(1)</sup>**

Pin #	SER	DES	Pin #	SER	DES
1	M/S*		21	G0	B0
2	RM1		22	G1	G5
3	V <sub>DDA</sub>		23	G2	G4
4	MD1		24	G3	
5	MD0V <sub>SSA</sub>		25	V <sub>SScore</sub>	
6	MC		26	V <sub>DDcore</sub>	
7	MD0	MD1	27	G4	G2
8	RM0		28	G5	G1
9	RGB*		29	B0	G0
10	PDOUT*	HS	30	B1	R5
11	TM		31	B2	R4
12	PCLK	VS	32	B3	R3
13	R0	DE	33	B4	R2
14	R1	B5	34	B5	R1
15	V <sub>SSIO</sub>		35	V <sub>SSIO</sub>	
16	V <sub>DDIO</sub>		36	V <sub>DDIO</sub>	
17	R2	B4	37	DE	R0
18	R3	B3	38	VS	PCLK
19	R4	B2	39	HS	PE
20	R5	B1	40	PD*	
DAP	GND		DAP	GND	

(1) Note: Pins are different between SER and DES configurations.

---

**REVISION HISTORY**

<b>Changes from Revision A (May 2013) to Revision B</b>	<b>Page</b>
• Changed layout of National Data Sheet to TI format .....	<a href="#">18</a>

---

**PACKAGING INFORMATION**

Orderable Device	Status (1)	Package Type	Package Drawing	Pins	Package Qty	Eco Plan (2)	Lead/Ball Finish (6)	MSL Peak Temp (3)	Op Temp (°C)	Device Marking (4/5)	Samples
LM2506GR/NOPB	ACTIVE	csBGA	NYC	49	1000	Green (RoHS & no Sb/Br)	CU SNAGCU	Level-1-260C-UNLIM	-30 to 85	L2506GR	<a href="#">Samples</a>
LM2506GRX/NOPB	ACTIVE	csBGA	NYC	49	3500	Green (RoHS & no Sb/Br)	CU SNAGCU	Level-1-260C-UNLIM	-30 to 85	L2506GR	<a href="#">Samples</a>
LM2506SQ/NOPB	ACTIVE	WQFN	RSB	40	1000	Green (RoHS & no Sb/Br)	CU SN	Level-3-260C-168 HR	-30 to 85	L2506SQ	<a href="#">Samples</a>
LM2506SQX/NOPB	ACTIVE	WQFN	RSB	40	4500	Green (RoHS & no Sb/Br)	CU SN	Level-3-260C-168 HR	-30 to 85	L2506SQ	<a href="#">Samples</a>

(1) The marketing status values are defined as follows:

**ACTIVE:** Product device recommended for new designs.

**LIFEBUY:** TI has announced that the device will be discontinued, and a lifetime-buy period is in effect.

**NRND:** Not recommended for new designs. Device is in production to support existing customers, but TI does not recommend using this part in a new design.

**PREVIEW:** Device has been announced but is not in production. Samples may or may not be available.

**OBSELETE:** TI has discontinued the production of the device.

(2) Eco Plan - The planned eco-friendly classification: Pb-Free (RoHS), Pb-Free (RoHS Exempt), or Green (RoHS & no Sb/Br) - please check <http://www.ti.com/productcontent> for the latest availability information and additional product content details.

**TBD:** The Pb-Free/Green conversion plan has not been defined.

**Pb-Free (RoHS):** TI's terms "Lead-Free" or "Pb-Free" mean semiconductor products that are compatible with the current RoHS requirements for all 6 substances, including the requirement that lead not exceed 0.1% by weight in homogeneous materials. Where designed to be soldered at high temperatures, TI Pb-Free products are suitable for use in specified lead-free processes.

**Pb-Free (RoHS Exempt):** This component has a RoHS exemption for either 1) lead-based flip-chip solder bumps used between the die and package, or 2) lead-based die adhesive used between the die and leadframe. The component is otherwise considered Pb-Free (RoHS compatible) as defined above.

**Green (RoHS & no Sb/Br):** TI defines "Green" to mean Pb-Free (RoHS compatible), and free of Bromine (Br) and Antimony (Sb) based flame retardants (Br or Sb do not exceed 0.1% by weight in homogeneous material)

(3) MSL, Peak Temp. - The Moisture Sensitivity Level rating according to the JEDEC industry standard classifications, and peak solder temperature.

(4) There may be additional marking, which relates to the logo, the lot trace code information, or the environmental category on the device.

(5) Multiple Device Markings will be inside parentheses. Only one Device Marking contained in parentheses and separated by a "~" will appear on a device. If a line is indented then it is a continuation of the previous line and the two combined represent the entire Device Marking for that device.

(6) Lead/Ball Finish - Orderable Devices may have multiple material finish options. Finish options are separated by a vertical ruled line. Lead/Ball Finish values may wrap to two lines if the finish value exceeds the maximum column width.

**Important Information and Disclaimer:**The information provided on this page represents TI's knowledge and belief as of the date that it is provided. TI bases its knowledge and belief on information provided by third parties, and makes no representation or warranty as to the accuracy of such information. Efforts are underway to better integrate information from third parties. TI has taken and continues to take reasonable steps to provide representative and accurate information but may not have conducted destructive testing or chemical analysis on incoming materials and chemicals. TI and TI suppliers consider certain information to be proprietary, and thus CAS numbers and other limited information may not be available for release.

In no event shall TI's liability arising out of such information exceed the total purchase price of the TI part(s) at issue in this document sold by TI to Customer on an annual basis.

**TAPE AND REEL INFORMATION**

**QUADRANT ASSIGNMENTS FOR PIN 1 ORIENTATION IN TAPE**

\*All dimensions are nominal

Device	Package Type	Package Drawing	Pins	SPQ	Reel Diameter (mm)	Reel Width W1 (mm)	A0 (mm)	B0 (mm)	K0 (mm)	P1 (mm)	W (mm)	Pin1 Quadrant
LM2506GR/NOPB	csBGA	NYC	49	1000	178.0	12.4	4.3	4.3	1.5	8.0	12.0	Q1
LM2506GRX/NOPB	csBGA	NYC	49	3500	330.0	12.4	4.3	4.3	1.5	8.0	12.0	Q1
LM2506SQ/NOPB	WQFN	RSB	40	1000	178.0	12.4	5.3	5.3	1.3	8.0	12.0	Q1
LM2506SQX/NOPB	WQFN	RSB	40	4500	330.0	12.4	5.3	5.3	1.3	8.0	12.0	Q1

**TAPE AND REEL BOX DIMENSIONS**

\*All dimensions are nominal

Device	Package Type	Package Drawing	Pins	SPQ	Length (mm)	Width (mm)	Height (mm)
LM2506GR/NOPB	csBGA	NYC	49	1000	210.0	185.0	35.0
LM2506GRX/NOPB	csBGA	NYC	49	3500	367.0	367.0	35.0
LM2506SQ/NOPB	WQFN	RSB	40	1000	213.0	191.0	55.0
LM2506SQX/NOPB	WQFN	RSB	40	4500	367.0	367.0	35.0

NYC0049A

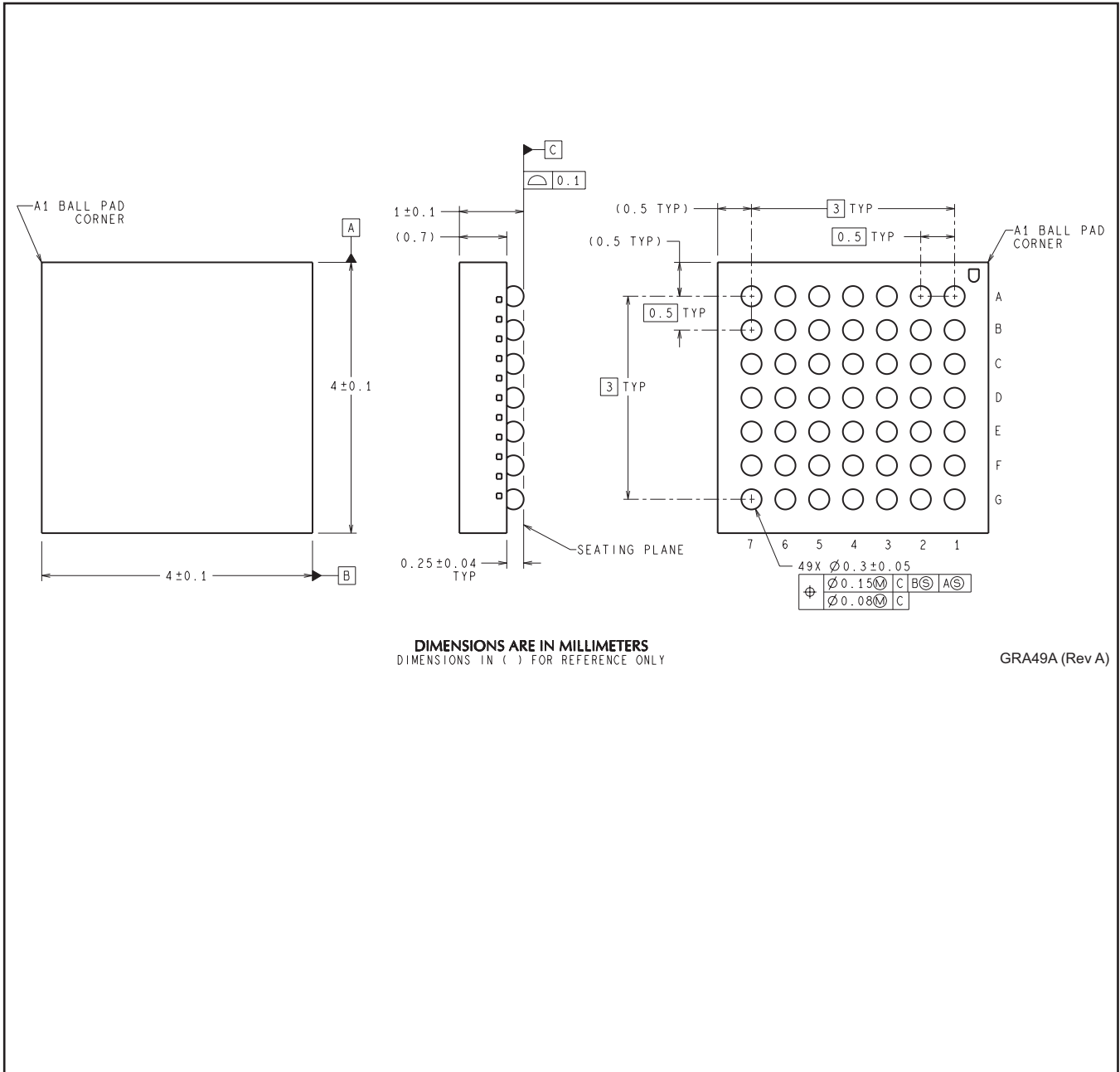

DIMENSIONS ARE IN MILLIMETERS  
DIMENSIONS IN ( ) FOR REFERENCE ONLY

GRA49A (Rev A)

RSB0040A

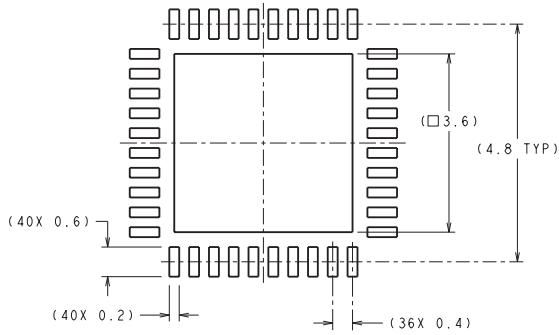

DIMENSIONS ARE IN MILLIMETERS  
DIMENSIONS IN ( ) FOR REFERENCE ONLY

RECOMMENDED LAND PATTERN

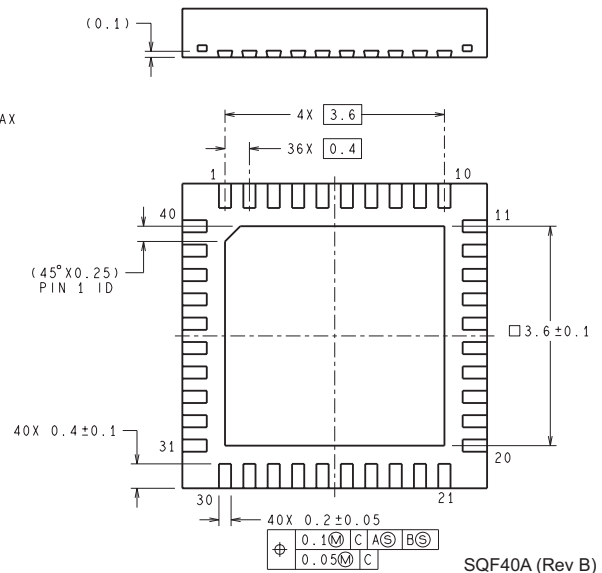
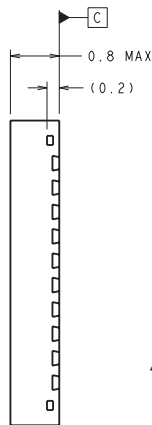
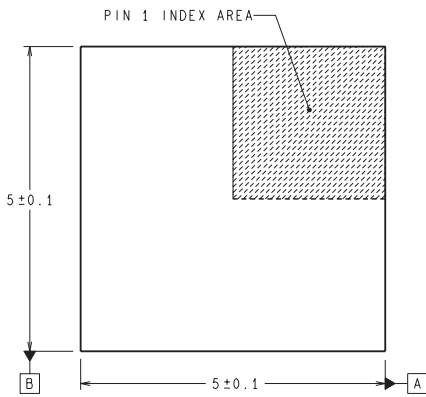

SQF40A (Rev B)

## IMPORTANT NOTICE

Texas Instruments Incorporated and its subsidiaries (TI) reserve the right to make corrections, enhancements, improvements and other changes to its semiconductor products and services per JESD46, latest issue, and to discontinue any product or service per JESD48, latest issue. Buyers should obtain the latest relevant information before placing orders and should verify that such information is current and complete. All semiconductor products (also referred to herein as "components") are sold subject to TI's terms and conditions of sale supplied at the time of order acknowledgment.

TI warrants performance of its components to the specifications applicable at the time of sale, in accordance with the warranty in TI's terms and conditions of sale of semiconductor products. Testing and other quality control techniques are used to the extent TI deems necessary to support this warranty. Except where mandated by applicable law, testing of all parameters of each component is not necessarily performed.

TI assumes no liability for applications assistance or the design of Buyers' products. Buyers are responsible for their products and applications using TI components. To minimize the risks associated with Buyers' products and applications, Buyers should provide adequate design and operating safeguards.

TI does not warrant or represent that any license, either express or implied, is granted under any patent right, copyright, mask work right, or other intellectual property right relating to any combination, machine, or process in which TI components or services are used. Information published by TI regarding third-party products or services does not constitute a license to use such products or services or a warranty or endorsement thereof. Use of such information may require a license from a third party under the patents or other intellectual property of the third party, or a license from TI under the patents or other intellectual property of TI.

Reproduction of significant portions of TI information in TI data books or data sheets is permissible only if reproduction is without alteration and is accompanied by all associated warranties, conditions, limitations, and notices. TI is not responsible or liable for such altered documentation. Information of third parties may be subject to additional restrictions.

Resale of TI components or services with statements different from or beyond the parameters stated by TI for that component or service voids all express and any implied warranties for the associated TI component or service and is an unfair and deceptive business practice. TI is not responsible or liable for any such statements.

Buyer acknowledges and agrees that it is solely responsible for compliance with all legal, regulatory and safety-related requirements concerning its products, and any use of TI components in its applications, notwithstanding any applications-related information or support that may be provided by TI. Buyer represents and agrees that it has all the necessary expertise to create and implement safeguards which anticipate dangerous consequences of failures, monitor failures and their consequences, lessen the likelihood of failures that might cause harm and take appropriate remedial actions. Buyer will fully indemnify TI and its representatives against any damages arising out of the use of any TI components in safety-critical applications.

In some cases, TI components may be promoted specifically to facilitate safety-related applications. With such components, TI's goal is to help enable customers to design and create their own end-product solutions that meet applicable functional safety standards and requirements. Nonetheless, such components are subject to these terms.

No TI components are authorized for use in FDA Class III (or similar life-critical medical equipment) unless authorized officers of the parties have executed a special agreement specifically governing such use.

Only those TI components which TI has specifically designated as military grade or "enhanced plastic" are designed and intended for use in military/aerospace applications or environments. Buyer acknowledges and agrees that any military or aerospace use of TI components which have **not** been so designated is solely at the Buyer's risk, and that Buyer is solely responsible for compliance with all legal and regulatory requirements in connection with such use.

TI has specifically designated certain components as meeting ISO/TS16949 requirements, mainly for automotive use. In any case of use of non-designated products, TI will not be responsible for any failure to meet ISO/TS16949.

### Products

Audio	<a href="http://www.ti.com/audio">www.ti.com/audio</a>
Amplifiers	<a href="http://amplifier.ti.com">amplifier.ti.com</a>
Data Converters	<a href="http://dataconverter.ti.com">dataconverter.ti.com</a>
DLP® Products	<a href="http://www.dlp.com">www.dlp.com</a>
DSP	<a href="http://dsp.ti.com">dsp.ti.com</a>
Clocks and Timers	<a href="http://www.ti.com/clocks">www.ti.com/clocks</a>
Interface	<a href="http://interface.ti.com">interface.ti.com</a>
Logic	<a href="http://logic.ti.com">logic.ti.com</a>
Power Mgmt	<a href="http://power.ti.com">power.ti.com</a>
Microcontrollers	<a href="http://microcontroller.ti.com">microcontroller.ti.com</a>
RFID	<a href="http://www.ti-rfid.com">www.ti-rfid.com</a>
OMAP Applications Processors	<a href="http://www.ti.com/omap">www.ti.com/omap</a>
Wireless Connectivity	<a href="http://www.ti.com/wirelessconnectivity">www.ti.com/wirelessconnectivity</a>

### Applications

Automotive and Transportation	<a href="http://www.ti.com/automotive">www.ti.com/automotive</a>
Communications and Telecom	<a href="http://www.ti.com/communications">www.ti.com/communications</a>
Computers and Peripherals	<a href="http://www.ti.com/computers">www.ti.com/computers</a>
Consumer Electronics	<a href="http://www.ti.com/consumer-apps">www.ti.com/consumer-apps</a>
Energy and Lighting	<a href="http://www.ti.com/energy">www.ti.com/energy</a>
Industrial	<a href="http://www.ti.com/industrial">www.ti.com/industrial</a>
Medical	<a href="http://www.ti.com/medical">www.ti.com/medical</a>
Security	<a href="http://www.ti.com/security">www.ti.com/security</a>
Space, Avionics and Defense	<a href="http://www.ti.com/space-avionics-defense">www.ti.com/space-avionics-defense</a>
Video and Imaging	<a href="http://www.ti.com/video">www.ti.com/video</a>

### TI E2E Community

[e2e.ti.com](http://e2e.ti.com)