

COVERED BY ONE OR MORE OF THE FOLLOWING PATENTS:  
 6142435; D 430,499; 431,920; 422,485.  
 INTERNATIONAL PATENT PENDING

PART NO.	DIM. "A" ±.015 [0.4]
LKSA-2-3-01	3/16 [4.8]
LKSA-2-4-01	1/4 [6.4]
LKSA-2-5-01	5/16 [7.9]
LKSA-2-6-01	3/8 [9.5]
LKSA-2-7-01	7/16 [11.1]
LKSA-2-8-01	1/2 [12.7]
LKSA-2-9-01	9/16 [14.3]
LKSA-2-10-01	5/8 [15.9]

TO SNAP-LOCK IN A .125±.002  
 [3.18±0.05] DIA. HOLE, IN A  
 .031-.078 [0.79-1.98] PANEL THICKNESS

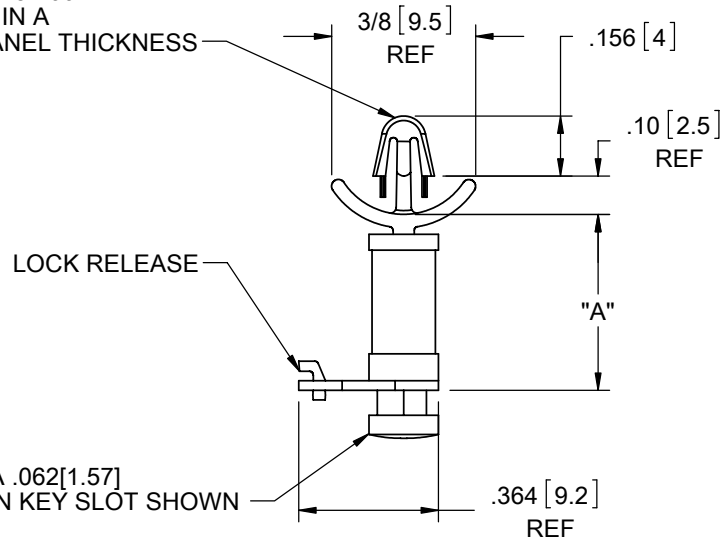
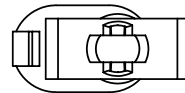

TO "SLIDE-LOCK" IN A .062[1.57]  
 PANEL THICKNESS, IN KEY SLOT SHOWN

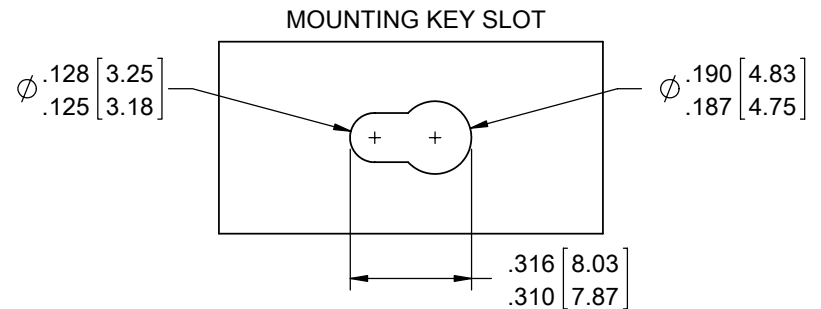
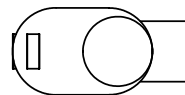
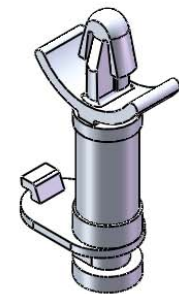
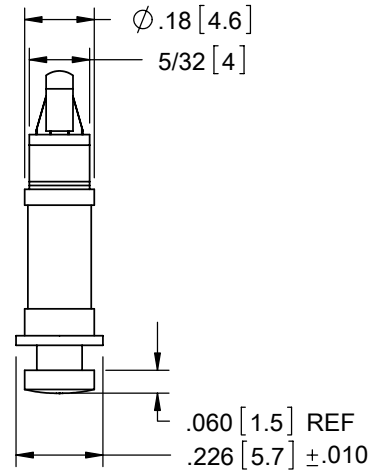

NOTES:

- MATERIAL: NYLON 6/6 UL 94 V-2 (RMS-01).  
 MATERIAL: NYLON 6/6 UL 94 V-0 (RMS-19),  
 AVAILABLE BY SPECIAL ORDER ONLY.
- COLOR: NATURAL.
- ALTERNATE UNITS FOR REFERENCE ONLY.

REV.	DESCRIPTION	ENGR.	DATE
C	REDRAWN, SEE ECN #1208 FOR CHANGES	SK	11/29/06
-	SEE ENGINEERING FOR REV A-B	-	----

TITLE: <b>LOCKING KEY SLOT 2-.125 ARROWHEAD</b>						DWG IN IN [MM] FINAL			
CREATED USING SOLIDWORKS TOLERANCES UNLESS NOTED XX=±.010 .XXX=±.005 FRAC.=±1/64 ANG.=±1°		FILE #: LKSA SHEET: 1 OF 1 SHEET SIZE: A RE: RICHCO, INC.	DWN: SK DT: 11/21/06	APP: RT CHKD: SJ	PART # <b>SEE TABLE</b>		PRINT TYPE <b>CA</b>		
RICHCO, INC. ENG@RICHCO-INC.COM (773) 539-4060									