

# Controller/Driver

## LEC□/JXC□ Series

### <Single Axis Controllers>

Step Data Input Type ..... Page 560

Step Motor  
(Servo/24 VDC)/  
LECP6 Series



Servo Motor  
(24 VDC)/  
LECA6 Series



Gateway Unit .. Page 572

LEC-G Series



Programless Type .. Page 576

Step Motor  
(Servo/24 VDC)/  
LECP1 Series



Programless Type  
(With Stroke Study) .... Page 583

Step Motor  
(Servo/24 VDC)/  
LECP2 Series

Specialized for LEM series



Pulse Input Type ... Page 590

Step Motor  
(Servo/24 VDC)/  
LECPA Series



CC-Link Direct Input Type ... Page 600

LECPMJ Series



EtherCAT®/EtherNet/IP™/PROFINET/DeviceNet™/IO-Link Direct Input Type ..... Page 603-5

JXC□ Series

EtherCAT®



EtherNet/IP™



PROFINET



DeviceNet™



IO-Link



### <Multi-Axis Controllers>

EtherNet/IP™ Direct Input Type ..... Page 606-1

For 3 axes JXC92 Series



Parallel I/O/EtherNet/IP™ Direct Input Type ..... Page 606-1

For 4 axes JXC73 Series  
JXC83 Series



JXC93 Series  
EtherNet/IP™





# Simple Setting to Use Straight Away

## Easy Mode for Simple Setting

If you want to use it right away, select "Easy Mode."

Step motor (Servo/24 VDC) **LECP6**

Servo motor (24 VDC) **LECA6**

### <When a PC is used> Controller setting software

- Step data setting, test drive, jogging and move for the constant rate can be set and operated on one screen.

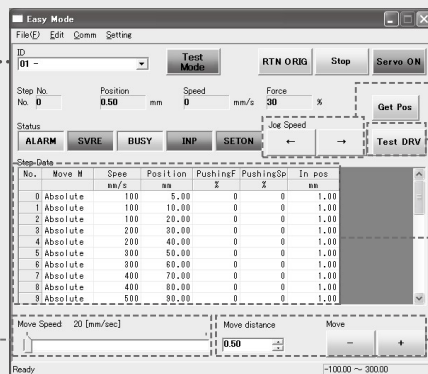

Jogging

Start testing

Step data setting

Move for the constant rate

Setting of jog and speed of the constant rate

### <When a TB (teaching box) is used>

- Simple screen without scrolling promotes ease of setting and operating.
- Pick up an icon from the first screen to select a function.
- Set up the step data and check the monitor on the second screen.



#### Example of setting the step data

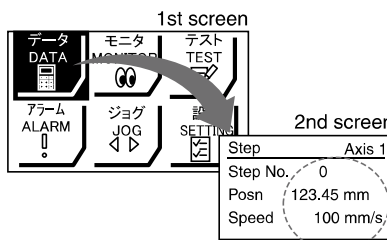

It can be registered by "SET" after entering the values.

#### Example of checking the operation status

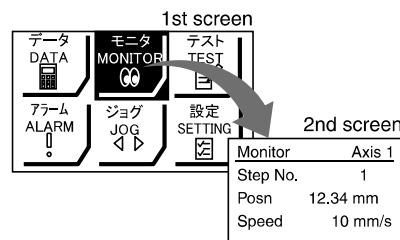

Operation status can be checked.

### Teaching box screen

- Data can be set with position and speed. (Other conditions are already set.)

Step	Axis 1
Step No.	0
Posn	50.00 mm
Speed	200 mm/s



Step	Axis 1
Step No.	1
Posn	80.00 mm
Speed	100 mm/s

## ⊙ Normal Mode for Detailed Setting

Select normal mode when detailed setting is required.

- Step data can be set in detail.
- Parameters can be set.
- Signals and terminal status can be monitored.
- JOG and constant rate movement, return to origin, test drive and testing of forced output can be performed.

### <When a PC is used> Controller setting software

- Step data setting, parameter setting, monitor, teaching, etc., are indicated in different windows.

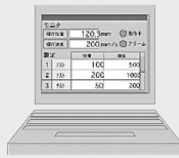

Step data setup window

Parameter setup window

Monitoring window

Teaching window

### <When a TB (teaching box) is used>

- Multiple step data can be stored in the teaching box, and transferred to the controller.
- Continuous test drive by up to 5 step data.

### Teaching box screen

- Each function (step data setting, test, monitor, etc.) can be selected from the main menu.

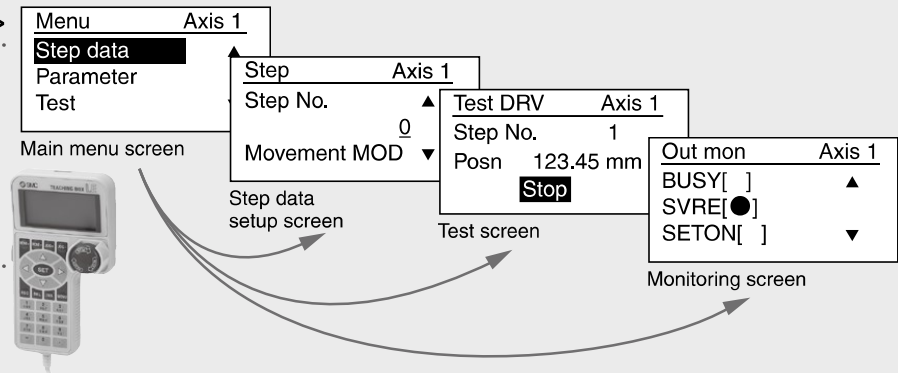

**The actuator and controller are provided as a set.** (They can be ordered separately.)

Confirm that the combination of the controller and the actuator is correct.

<Check the following before use.>

- ① Check the actuator label for model number. This matches the controller.
- ② Check Parallel I/O configuration matches (NPN or PNP).

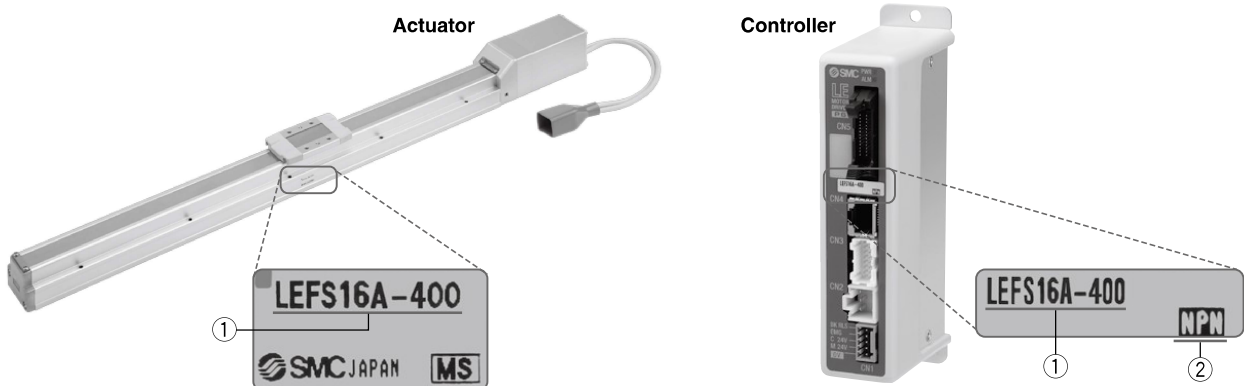

# Fieldbus Network

## CC-Link Direct Input Type Step Motor Controller LECPMJ Series ▶Page 600



- CC-Link Ver. 1.10 compliant
- External data import function

- The step data can be rewrite temporarily by feeding back external information to the PLC.
- 64 or more data points can be defined with the 3 types of data import modes.

Operation example: The opening width of the electric gripper is changed appropriately according to the results of the measurement with the imaging camera.

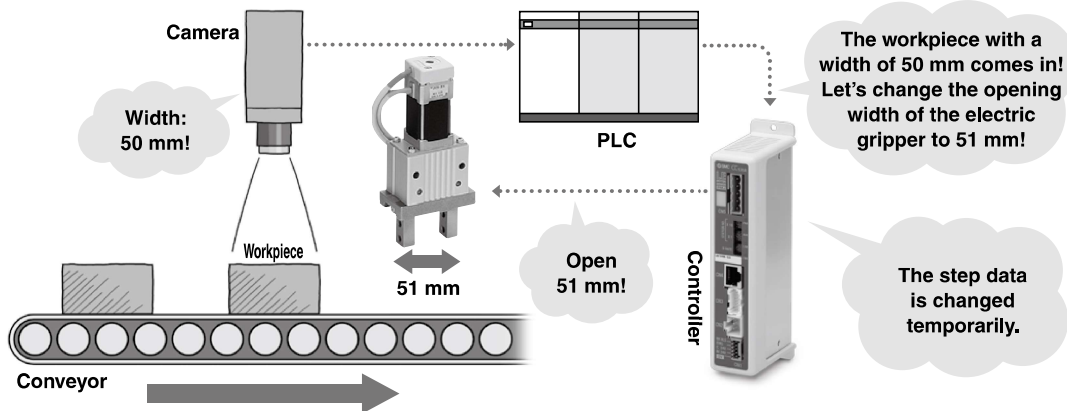

### ● 3 types of data import modes

- Single numeric parameter (Number of occupied stations: 1) Movement MOD (movement mode) and another parameter item are changed.
- Half numeric parameters (Number of occupied stations: 2) Up to 6 parameter items are changed at once.
- Full numeric parameters (Number of occupied stations: 4) Up to 12 parameter items are changed at once.

- Position and speed can be monitored by the PLC touch panel (display).
- Step data can be edited from the PLC touch panel (display). (Except in the case of the single numeric parameter)

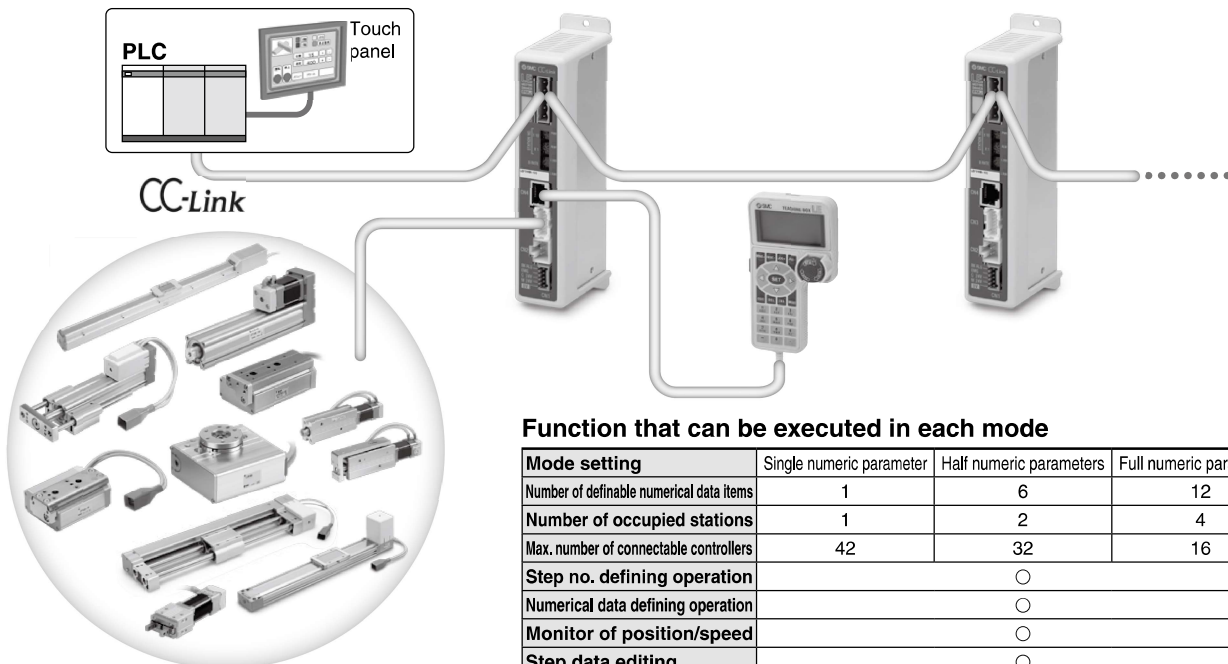

Function that can be executed in each mode

Mode setting	Single numeric parameter	Half numeric parameters	Full numeric parameters
Number of definable numerical data items	1	6	12
Number of occupied stations	1	2	4
Max. number of connectable controllers	42	32	16
Step no. defining operation		○	
Numerical data defining operation		○	
Monitor of position/speed		○	
Step data editing		○	

# EtherCAT®/EtherNet/IP™/PROFINET® DeviceNet™/IO-Link Direct Input Type Step Motor Controller/JXC□ Series

▶Page 603-5

IO-Link



EtherCAT



PROFINET



DeviceNet



EtherNet/IP



◎ **Two types of operation command**

**Step no. defined operation:** Operate using the preset step data in the controller.

**Numerical data defined operation:** The actuator operates using values such as position and speed from the PLC.

◎ **Numerical monitoring available**

Numerical information, such as the current speed, current position, and alarm codes, can be monitored on the PLC.

◎ **Transition wiring of communication cables**

Two communication ports are provided.

- \* For the DeviceNet™ type, transition wiring is possible using a branch connector.
- \* 1 to 1 in the case of IO-Link

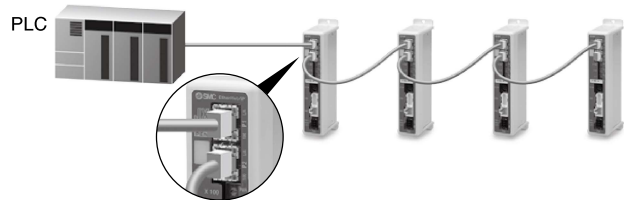

## Application

Communication protocols

EtherCAT

EtherNet/IP

PROFINET

DeviceNet

IO-Link



Both air and electric systems can be established under the same protocol.

Can be additionally installed in an existing network

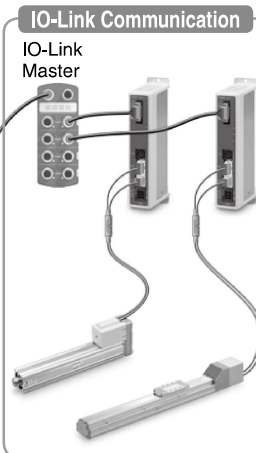
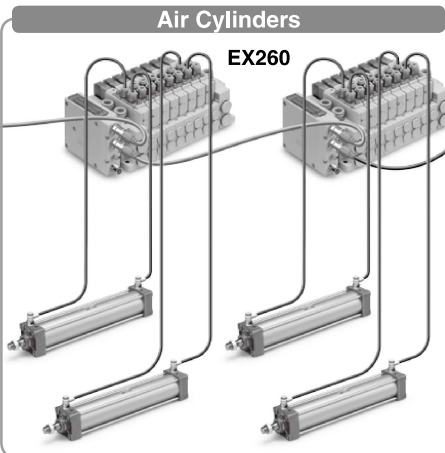

<Applicable Electric Actuators>



Slider Type  
LEF Series



Low Profile Slider Type  
LEM Series



Guide Rod Slider  
LEL Series

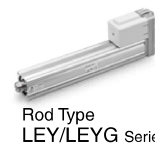

Rod Type  
LEY/LEYG Series



Slide Table  
LES/LESH Series



Miniature Type  
LEPY/LEPS Series



Gripper  
LEH Series



Rotary Table  
LER Series

# Fieldbus Network

## Fieldbus-compatible Gateway (GW) Unit LEC-G Series ▶Page 572



◎ Conversion unit for Fieldbus network and LEC serial communication

Applicable Fieldbus protocols: **CC-Link V2** **DeviceNet** **PROFIBUS** **EtherNet/IP**

◎ Two methods of operation

Step data input: Operate using preset step data in the controller.

Numerical data input: The actuator operates using values such as position and speed from the PLC.

◎ Values such as position, speed can be checked on the PLC.

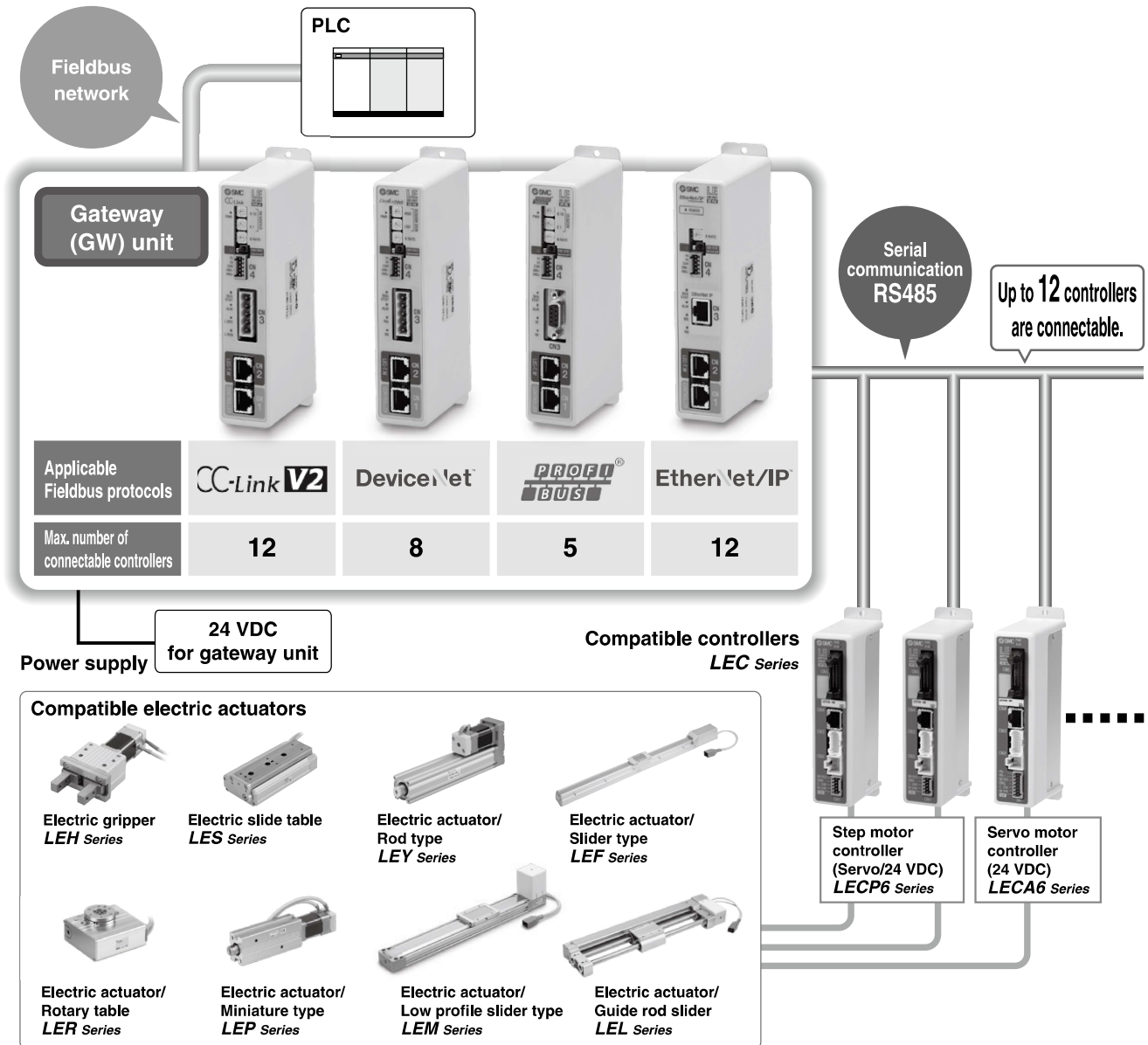



Step motor (Servo/24 VDC) **LECP1**

# No Programming

Capable of setting up an electric actuator operation without using a PC or teaching box

- ① Setting position number
- ② Setting a stop position
- ③ Registration

Setting a registered number for the stop position  
Maximum 14 points

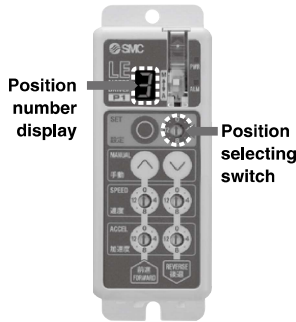

Moving the actuator to a stop position using FORWARD and REVERSE buttons



Registering the stop position using SET button

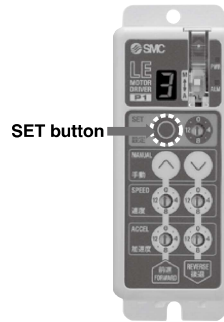

## Speed/Acceleration 16-level adjustment

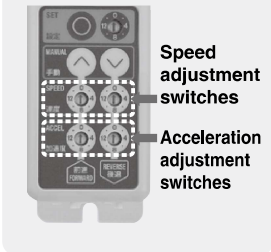

- A driver that uses pulse signals to allow positioning at any position. The actuator can be controlled from the customers' positioning unit.

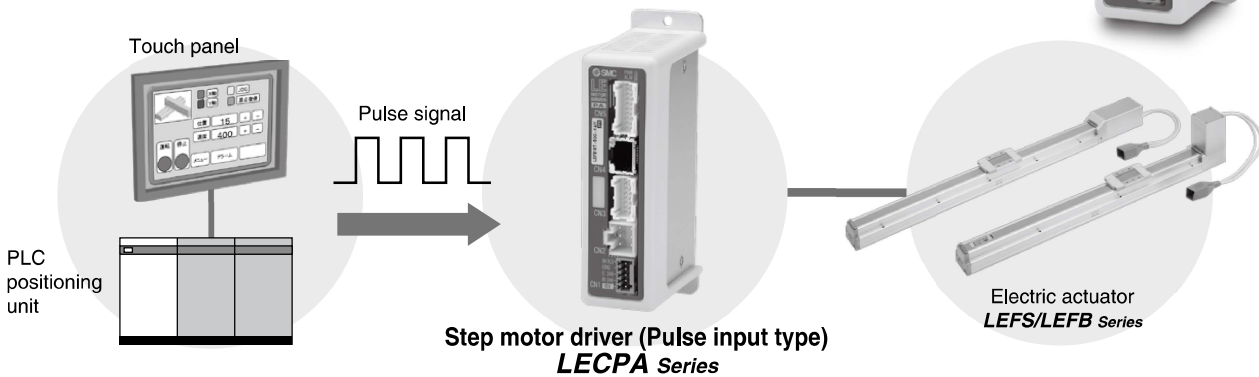

- **Return-to-origin command signal**  
Enables automatic return-to-origin action.
- **With force limit function (Pushing force/Gripping force operation available)**  
Pushing force/Positioning operation possible by switching signals.



Step motor (Servo/24 VDC) LECP2

# Stroke end operation similar to an air cylinder is possible.

(using the 1 stroke study and 2 reduced wiring below)

## 1 Stroke study (Simple registration of both stroke end positions)

After the stroke adjustment unit has travelled, both stroke ends are automatically registered by the stroke study function!

### 1 Setting position number

Set the position selecting switch to 15(F).

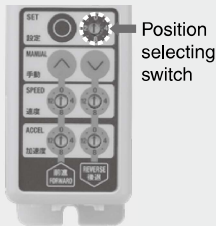

### 2 The stroke study begins

Press the SET button for 3 seconds or longer.



### Automatic registration of both end positions

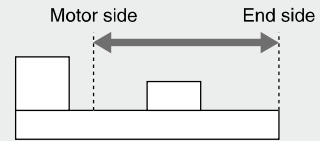

## 2 Wiring (Reduced wiring)

### 2-wire input signals\*

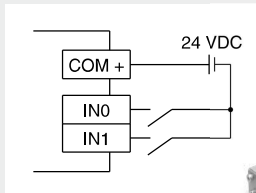

\* Both stroke end positions and an intermediate position can be set using this wiring.

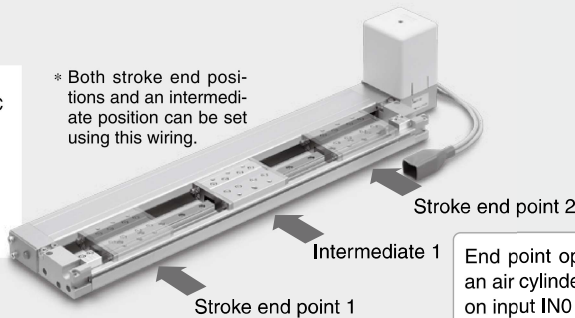

End point operation like an air cylinder by turning on input IN0 or IN1.

### Speed/Acceleration 16-level adjustment

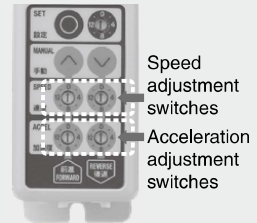

Speed adjustment switches  
Acceleration adjustment switches

## Compatible Actuators

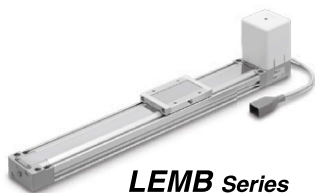

**LEMB Series**



**LEMC Series**



**LEMH Series**

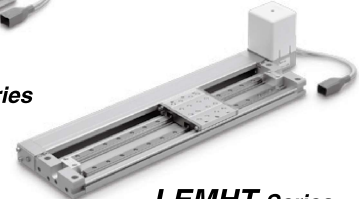

**LEMHT Series**

## Function

Item	Step data input type LECP6/LECA6	Programless type LECP1	Programless type (With stroke study) LECP2	Pulse input type LECPA
<b>Step data and parameter setting</b>	<ul style="list-style-type: none"> <li>• Input from controller setting software (PC)</li> <li>• Input from teaching box</li> </ul>	<ul style="list-style-type: none"> <li>• Select using controller operation buttons</li> </ul>	<ul style="list-style-type: none"> <li>• Select using controller operation buttons</li> </ul>	<ul style="list-style-type: none"> <li>• Input from controller setting software (PC)</li> <li>• Input from teaching box</li> </ul>
<b>Step data "position" setting</b>	<ul style="list-style-type: none"> <li>• Input the numerical value from controller setting software (PC) or teaching box</li> <li>• Input the numerical value</li> <li>• Direct teaching</li> <li>• JOG teaching</li> </ul>	<ul style="list-style-type: none"> <li>• Direct teaching</li> <li>• JOG teaching</li> </ul>	<ul style="list-style-type: none"> <li>• Stroke end: Automatic measurement</li> <li>• Intermediate position: Direct teaching JOG teaching</li> </ul>	<ul style="list-style-type: none"> <li>• No "Position" setting required</li> <li>Position and speed set by pulse signal</li> </ul>
<b>Number of step data</b>	64 points	14 points	2 stroke end points + 12 intermediate points (14 points in total)	—
<b>Operation command (I/O signal)</b>	Step No. [IN <sup>+</sup> ] input ⇒ [DRIVE] input	Step No. [IN <sup>+</sup> ] input only	Step No. [IN <sup>+</sup> ] input only	Pulse signal
<b>Completion signal</b>	[INP] output	[OUT <sup>+</sup> ] output	[OUT <sup>+</sup> ] output	[INP] output

## Setting Items

TB: Teaching box PC: Controller setting software

Item	Contents	Easy mode		Normal mode	Step data input type LECP6/LECA6	Pulse input type LECPA	Programless type LECP1*	Programless type (With stroke study) LECP2	
		TB	PC	TB-PC					
Step data setting (Excerpt)	<b>Movement MOD</b>	Selection of "absolute position" and "relative position"		△ ● ●	Set at Absolute/Relative	No setting required	Fixed value (Absolute)	Fixed value (Absolute)	
	<b>Speed</b>	Transfer speed		● ● ●	Set in units of 1 mm/s		Select from 16-level	Select from 16-level	
	<b>Position</b>	[Position]: Target position [Pushing]: Pushing start position		● ● ●	Set in units of 0.01 mm		Direct teaching JOG teaching	Stroke end: Automatic measurement Intermediate position: Direct teaching JOG teaching	
	<b>Acceleration/Deceleration</b>	Acceleration/deceleration during movement		● ● ●	Set in units of 1 mm/s <sup>2</sup>		Select from 16-level	Select from 16-level	
	<b>Pushing force</b>	Rate of force during pushing operation		● ● ●	Set in units of 1%		Set in units of 1%	Select from 3-level (weak, medium, strong)	No setting required
	<b>Trigger LV</b>	Target force during pushing operation		△ ● ●	Set in units of 1%		Set in units of 1%	No setting required (same value as pushing force)	
	<b>Pushing speed</b>	Speed during pushing operation		△ ● ●	Set in units of 1 mm/s		Set in units of 1 mm/s	No setting required	
	<b>Moving force</b>	Force during positioning operation		△ ● ●	Set to 100%		Set to (Different values for each actuator) %		
	<b>Area output</b>	Conditions for area output signal to turn ON		△ ● ●	Set in units of 0.01 mm		Set in units of 0.01 mm		
	<b>In position</b>	[Position]: Width to the target position [Pushing]: How much it moves during pushing		△ ● ●	Set to 0.5 mm or more (Units: 0.01 mm)		Set to (Different values for each actuator) or more (Units: 0.01 mm)		
Parameter setting (Excerpt)	<b>Stroke (+)</b>	+ side limit of position		× × ●	Set in units of 0.01 mm	Set in units of 0.01 mm			
	<b>Stroke (-)</b>	- side limit of position		× × ●	Set in units of 0.01 mm	Set in units of 0.01 mm			
	<b>ORIG direction</b>	Direction of the return to origin can be set.		× × ●	Compatible	Compatible			
	<b>ORIG speed</b>	Speed during return to origin		× × ●	Set in units of 1 mm/s	Set in units of 1 mm/s			
	<b>ORIG ACC</b>	Acceleration during return to origin		× × ●	Set in units of 1 mm/s <sup>2</sup>	Set in units of 1 mm/s <sup>2</sup>	No setting required		
Test	<b>JOG</b>			● ● ●	Continuous operation at the set speed can be tested while the switch is being pressed.	Continuous operation at the set speed can be tested while the switch is being pressed.	Hold down MANUAL button (⊙⊙) for uniform sending (speed is specified value)	Hold down MANUAL button (⊙⊙) for uniform sending (speed is specified value)	
	<b>MOVE</b>			× ● ●	Operation at the set distance and speed from the current position can be tested.	Operation at the set distance and speed from the current position can be tested.	Press MANUAL button (⊙⊙) once for sizing operation (speed, sizing amount are specified values)	Press MANUAL button (⊙⊙) once for sizing operation (speed, sizing amount are specified values)	
	<b>Return to ORIG</b>			● ● ●	Compatible	Compatible	Compatible	Performed by the stroke endpoint operation when power is turned ON.	
	<b>Test drive</b>	Operation of the specified step data		● ● ● (Continuous operation)	Compatible	Not compatible	Compatible	Compatible	
	<b>Forced output</b>	ON/OFF of the output terminal can be tested.		× × ●	Compatible	Compatible			
Monitor	<b>DRV mon</b>	Current position, speed, force and the specified step data can be monitored.		● ● ●	Compatible	Compatible	Not compatible	Not compatible	
	<b>In/Out mon</b>	Current ON/OFF status of the input and output terminal can be monitored.		× × ●	Compatible	Compatible			
ALM	<b>Status</b>	Alarm currently being generated can be confirmed.		● ● ●	Compatible	Compatible	Compatible (display alarm group)	Compatible (display alarm group)	
	<b>ALM Log record</b>	Alarm generated in the past can be confirmed.		× × ●	Compatible	Compatible			
<b>File</b>	<b>Save/Load</b>	Step data and parameter can be saved, forwarded and deleted.		× × ●	Compatible	Compatible	Not compatible	Not compatible	
<b>Other</b>	<b>Language</b>	Can be changed to Japanese or English.		● ● ●	Compatible	Compatible			

△: Can be set from TB Ver. 2.\*\* (The version information is displayed on the initial screen)

\* Programless type LECP1 cannot be used with the teaching box and controller setting kit.

# Multi-Axis Step Motor Controller

- Speed tuning control\*1  
(3 Axes: JXC92 4 Axes: JXC73/83/93)
- Linear/circular interpolation

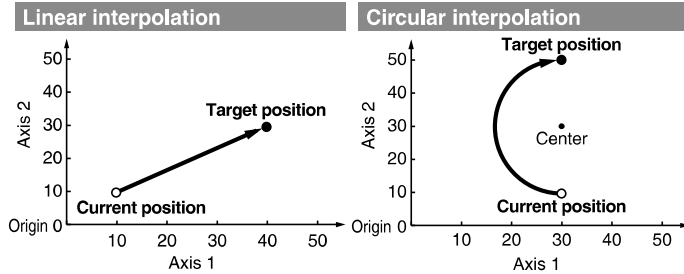

- Positioning/pushing operation
- Step data input  
(Max. 2048 points)
- Space saving, reduced wiring
- Absolute/relative position coordinate instructions

\*1 This controls the speed of the slave axis when the speed of the main axis drops due to the effects of an external force and when a speed difference with the slave axis occurs. This control is not for synchronizing the position of the main axis and slave axis.

## For 3 Axes JXC92 Series

- EtherNet/IP™ Type
- Width: Approx. 38% reduction

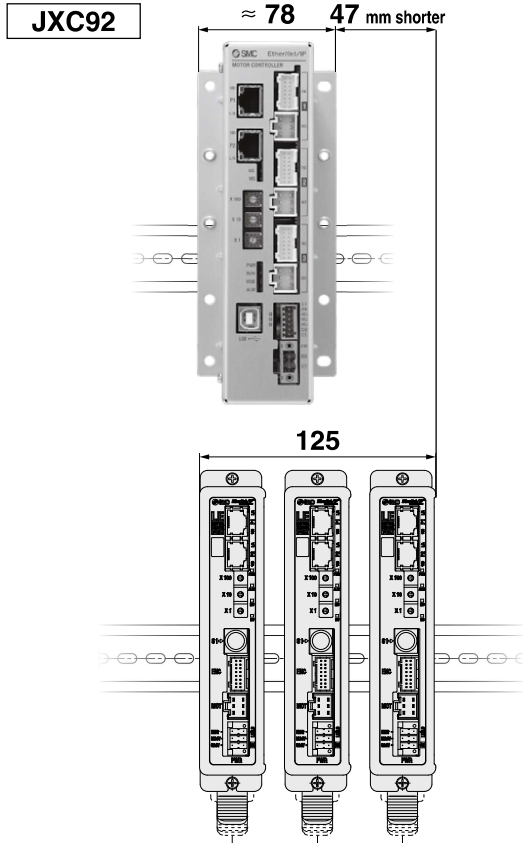

## For 4 Axes JXC73/83/93 Series

- Parallel I/O/  
EtherNet/IP™ Type
- Width: Approx. 18% reduction

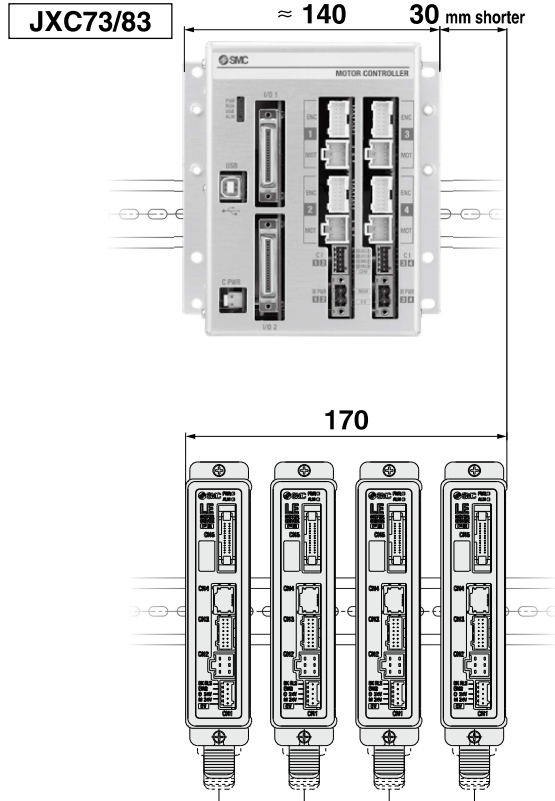

\* For LE□, size 25 or larger

# Step Data Input: Max. 2048 points



**For 3 Axes** 3-axis operation can be set collectively in one step.

Step	Axis	Movement mode	Speed mm/s	Position mm	Acceleration mm/s <sup>2</sup>	Deceleration mm/s <sup>2</sup>	Pushing force	Trigger LV	Pushing speed	Moving force	Area 1	Area 2	In position	Comments
											mm	mm	mm	
0	Axis 1	ABS	500	100.00	3000	3000	0	85.0	50	100.0	10.0	30.0	0.5	
	Axis 2	ABS	500	100.00	3000	3000	0	85.0	50	100.0	10.0	30.0	0.5	
	Axis 3	ABS	500	100.00	3000	3000	0	85.0	50	100.0	10.0	30.0	0.5	
1	Axis 1	INC	500	200.00	3000	3000	0	85.0	50	100.0	0	0	0.5	
	Axis 2	INC	500	200.00	3000	3000	0	85.0	50	100.0	0	0	0.5	
	Axis 3	INC	500	200.00	3000	3000	0	85.0	50	100.0	0	0	0.5	
⋮	⋮	⋮	⋮	⋮	⋮	⋮	⋮	⋮	⋮	⋮	⋮	⋮	⋮	
2046	Axis 1	SYN-I	500	100.00	3000	3000	0	0	0	100.0	0	0	0.5	
	Axis 2	SYN-I	0	0.00	0	0	0	0	0	100.0	0	0	0.5	
	Axis 3	SYN-I	0	0.00	0	0	0	0	0	100.0	0	0	0.5	
2047	Axis 1	CIR-R	500	0.00	3000	3000	0	0	0	100.0	0	0	0.5	
	Axis 2	CIR-R	0	50.00	0	0	0	0	0	100.0	0	0	0.5	
	Axis 3 *1		0	0.00	0	0	0	0	0	100.0	0	0	0.5	
	Axis 4 *1		0	25.00	0	0	0	0	0	100.0	0	0	0.5	

\*1 When circular interpolation (CIR-R, CIR-L, CIR-3) is selected in the movement mode, input the X and Y coordinates in the rotation center position or input the X and Y coordinates in the passing position.

Movement mode	Pushing operation	Details
Blank	×	Invalid data (Invalid process)
ABS	○	Moves to the absolute coordinate position based on the origin of the actuator
INC	○	Moves to the relative coordinate position based on the current position
LIN-A	×	Moves to the absolute coordinate position based on the origin of the actuator by linear interpolation
LIN-I	×	Moves to the relative coordinate position based on the current position by linear interpolation
CIR-R*2	×	With Axis 1 assigned to the X-axis and Axis 2 to the Y-axis, it moves in the clockwise direction by circular interpolation. The target position and rotation center position are specified according to the relative coordinates from the current position. The position data is assigned as follows. Axis 1: Target position X Axis 2: Target position Y Axis 3 *1: Rotation center position X Axis 4 *1: Rotation center position Y
CIR-L*2	×	With Axis 1 assigned to the X-axis and Axis 2 to the Y-axis, it moves in the counter-clockwise direction by circular interpolation. The target position and rotation center position are specified according to the relative coordinates from the current position. The position data is assigned as follows. Axis 1: Target position X Axis 2: Target position Y Axis 3 *1: Rotation center position X Axis 4 *1: Rotation center position Y
SYN-I	×	Moves to the relative coordinate position based on the current position by speed tuning control *3
CIR-3*2	×	With Axis 1 assigned to the X-axis and Axis 2 to the Y-axis, it moves based on the three specified points by circular interpolation. The target position and passing position are specified according to the relative coordinates from the current position. The position data is assigned as follows. Axis 1: Target position X Axis 2: Target position Y Axis 3 *1: Passing position X Axis 4 *1: Passing position Y

\*2 Performs a circular operation on a plane using Axis 1 and Axis 2

\*3 This controls the speed of the slave axis when the speed of the main axis drops due to the effects of an external force and when a speed difference with the slave axis occurs. This control is not for synchronizing the position of the main axis and slave axis.



## For 4 Axes 4-axis operation can be set collectively in one step.

Step	Axis	Movement mode	Speed	Position	Acceleration	Deceleration	Positioning/ Pushing	Area 1	Area 2	In position	Comments
			mm/s	mm	mm/s <sup>2</sup>	mm/s <sup>2</sup>		mm	mm	mm	
0	Axis 1	ABS	100	200.00	1000	1000	0	6.0	12.0	0.5	
	Axis 2	ABS	50	100.00	1000	1000	0	6.0	12.0	0.5	
	Axis 3	ABS	50	100.00	1000	1000	0	6.0	12.0	0.5	
	Axis 4	ABS	50	100.00	1000	1000	0	6.0	12.0	0.5	
1	Axis 1	INC	500	250.00	1000	1000	1	0	0	20.0	
	Axis 2	INC	500	250.00	1000	1000	1	0	0	20.0	
	Axis 3	INC	500	250.00	1000	1000	1	0	0	20.0	
	Axis 4	INC	500	250.00	1000	1000	1	0	0	20.0	
⋮	⋮	⋮	⋮	⋮	⋮	⋮	⋮	⋮	⋮	⋮	
2046	Axis 4	ABS	200	700	500	500	0	0	0	0.5	
2047	Axis 1	ABS	500	0.00	3000	3000	0	0	0	0.5	
	Axis 2	ABS	500	0.00	3000	3000	0	0	0	0.5	
	Axis 3	ABS	500	0.00	3000	3000	0	0	0	0.5	
	Axis 4	ABS	500	0.00	3000	3000	0	0	0	0.5	

Movement mode	Pushing operation	Details
Blank	×	Invalid data (Invalid process)
ABS	○	Moves to the absolute coordinate position based on the origin of the actuator
INC	○	Moves to the relative coordinate position based on the current position
LIN-A	×	Moves to the absolute coordinate position based on the origin of the actuator by linear interpolation
LIN-I	×	Moves to the relative coordinate position based on the current position by linear interpolation
CIR-R*1	×	With Axis 1 assigned to the X-axis and Axis 2 to the Y-axis, it moves in the clockwise direction by circular interpolation. The target position and rotation center position are specified according to the relative coordinates from the current position. The position data is assigned as follows. Axis 1: Target position X Axis 2: Target position Y Axis 3: Rotation center position X Axis 4: Rotation center position Y
CIR-L*1	×	With Axis 1 assigned to the X-axis and Axis 2 to the Y-axis, it moves in the counter-clockwise direction by circular interpolation. The target position and rotation center position are specified according to the relative coordinates from the current position. The position data is assigned as follows. Axis 1: Target position X Axis 2: Target position Y Axis 3: Rotation center position X Axis 4: Rotation center position Y
SYN-I	×	Moves to the relative coordinate position based on the current position by speed tuning control *2

\*1 Performs a circular operation on a plane using Axis 1 and Axis 2

\*2 This controls the speed of the slave axis when the speed of the main axis drops due to the effects of an external force and when a speed difference with the slave axis occurs. This control is not for synchronizing the position of the main axis and slave axis.

## ● Controller Setting Software (Connection with a PC)

For 3 Axes JXC92 For 4 Axes JXC73/83/93

### Easy file management

Load	The step data is loaded from the file.
Save	The step data is saved in a file.
Upload	The step data is loaded from the controller.
Download	The step data is written in the controller.

### Abundant edit functions

Copy	The selected step data is copied to the clipboard.
Delete	The selected step data is deleted.
Cut	The selected step data is cut.
Paste (Insert)	The step data copied to the clipboard is inserted into the cursor's position.
Paste (Overwrite)	The step data copied to the clipboard overwrites the data at the cursor position.
Insert	A blank line is inserted in the selected step data line.

### Step data window



### Operation confirmation of entered step data

	Enter the step number to be executed.
	Executes the specified step number.
	Displays whether the step number is being executed or stopped.
	Performs a return to origin of all the valid axes.

# System Construction/General Purpose I/O

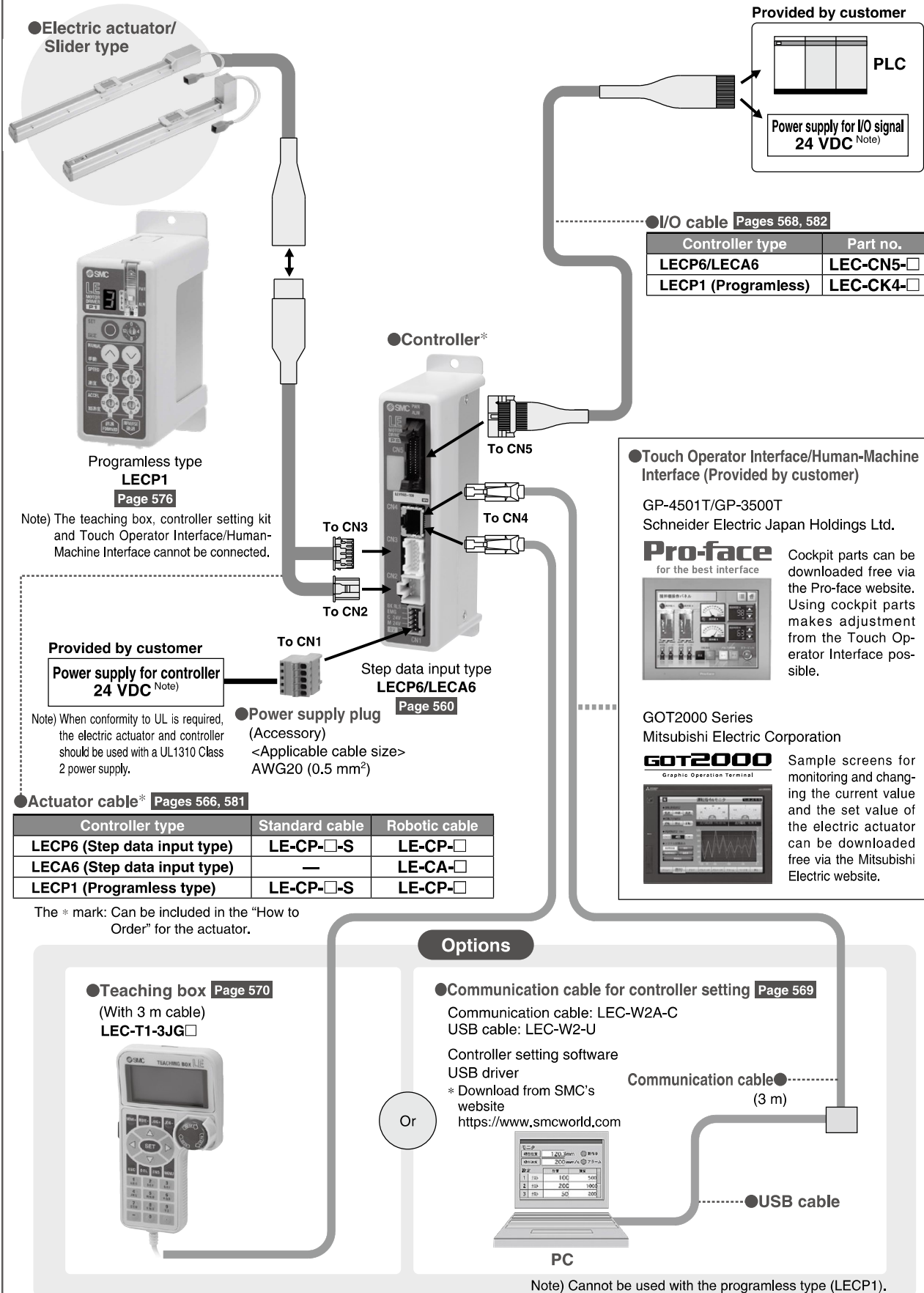

# System Construction/Pulse Signal

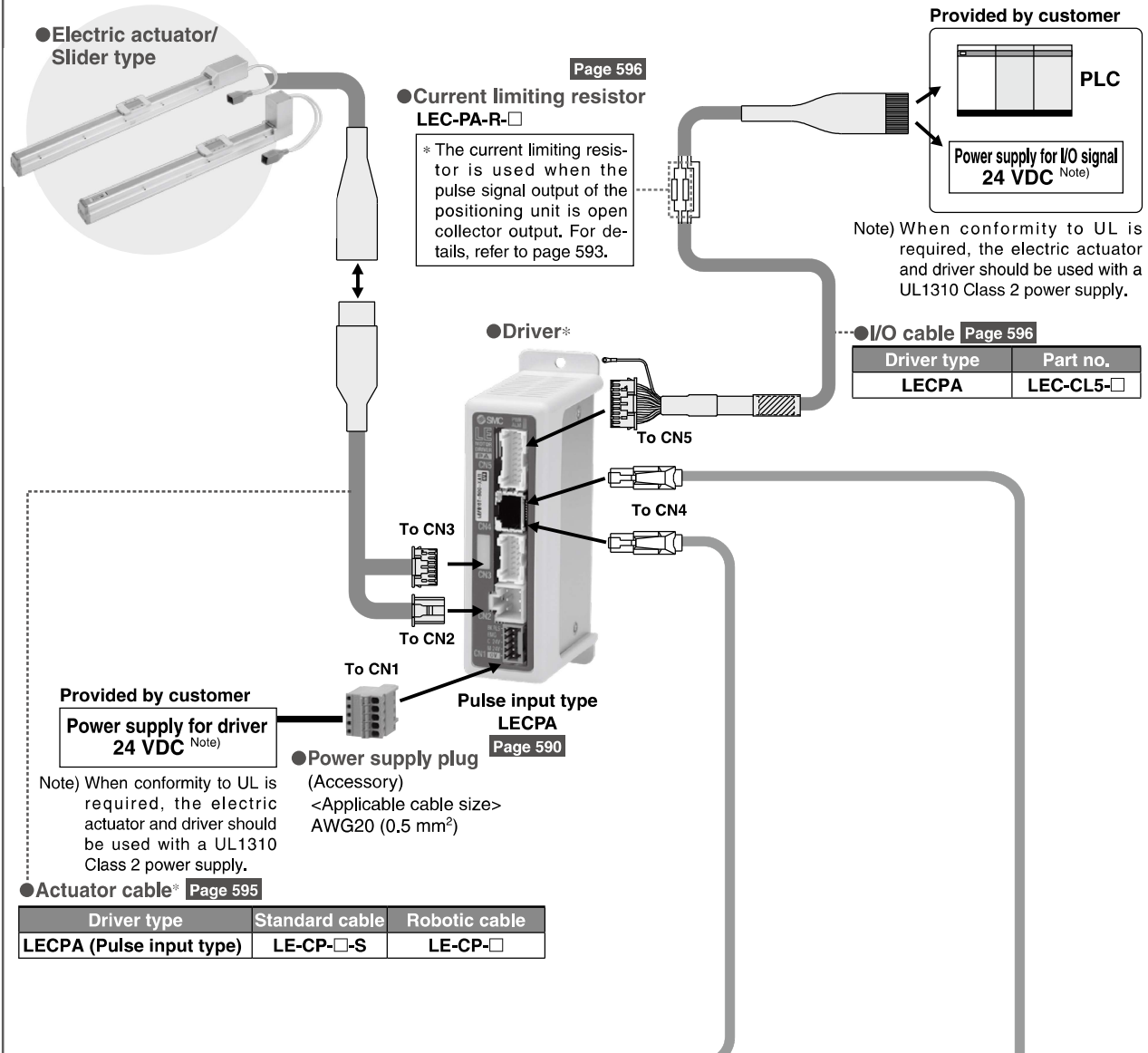

The \* mark: Can be included in the "How to Order" for the actuator.

## Options

- **Teaching box** Page 598  
(With 3 m cable)  
**LEC-T1-3JG**□



- **Communication cable for controller setting** Page 597  
Communication cable: LEC-W2A-C  
USB cable: LEC-W2-U

Controller setting software  
USB driver  
\* Download from SMC's website  
<https://www.smcworld.com>

Or

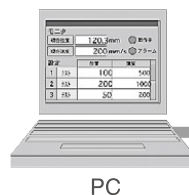

# System Construction/Programless Type

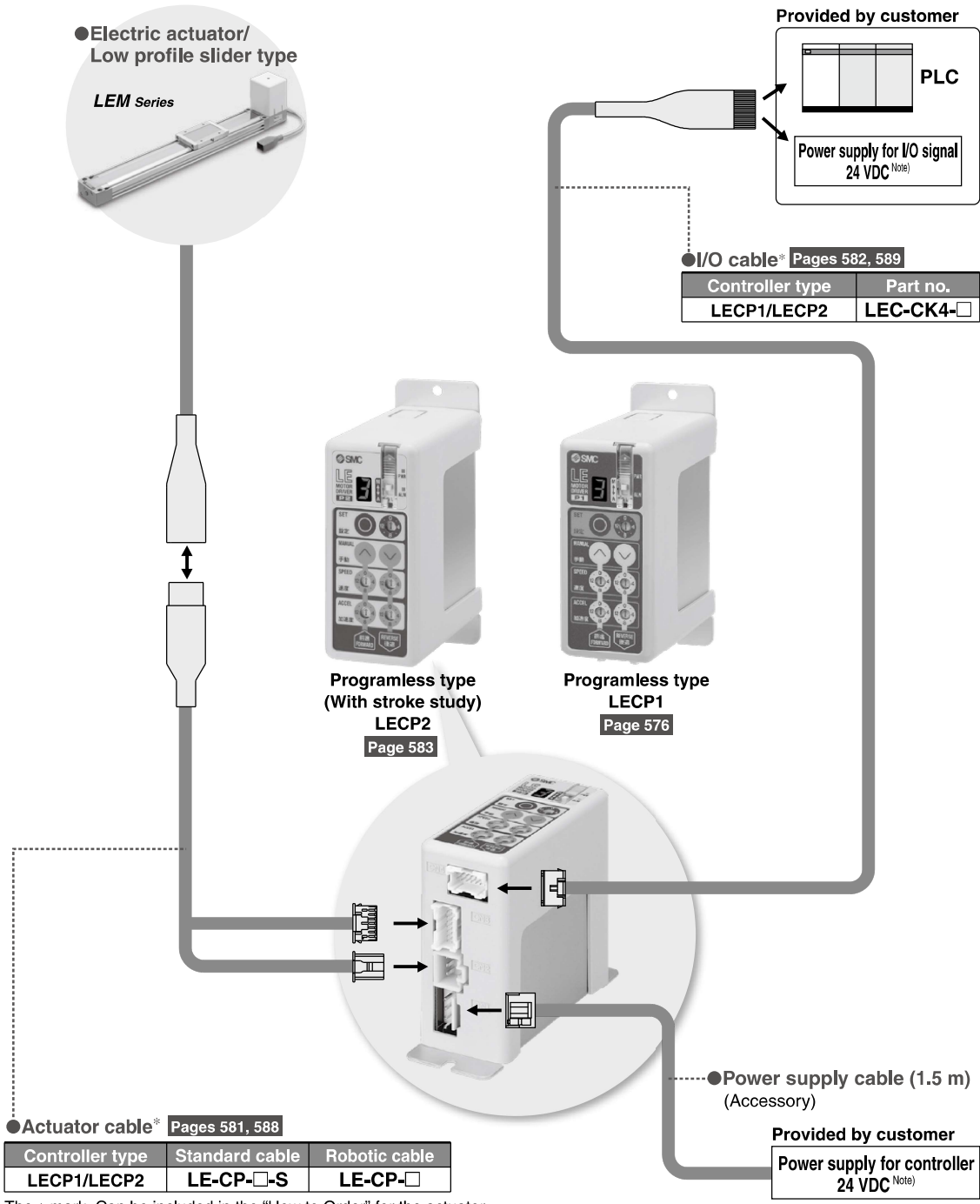

The \* mark: Can be included in the "How to Order" for the actuator.

Note) When conformity to UL is required, the electric actuator and controller should be used with a UL1310 Class 2 power supply.

# System Construction/Fieldbus Network (CC-Link Direct Input Type)

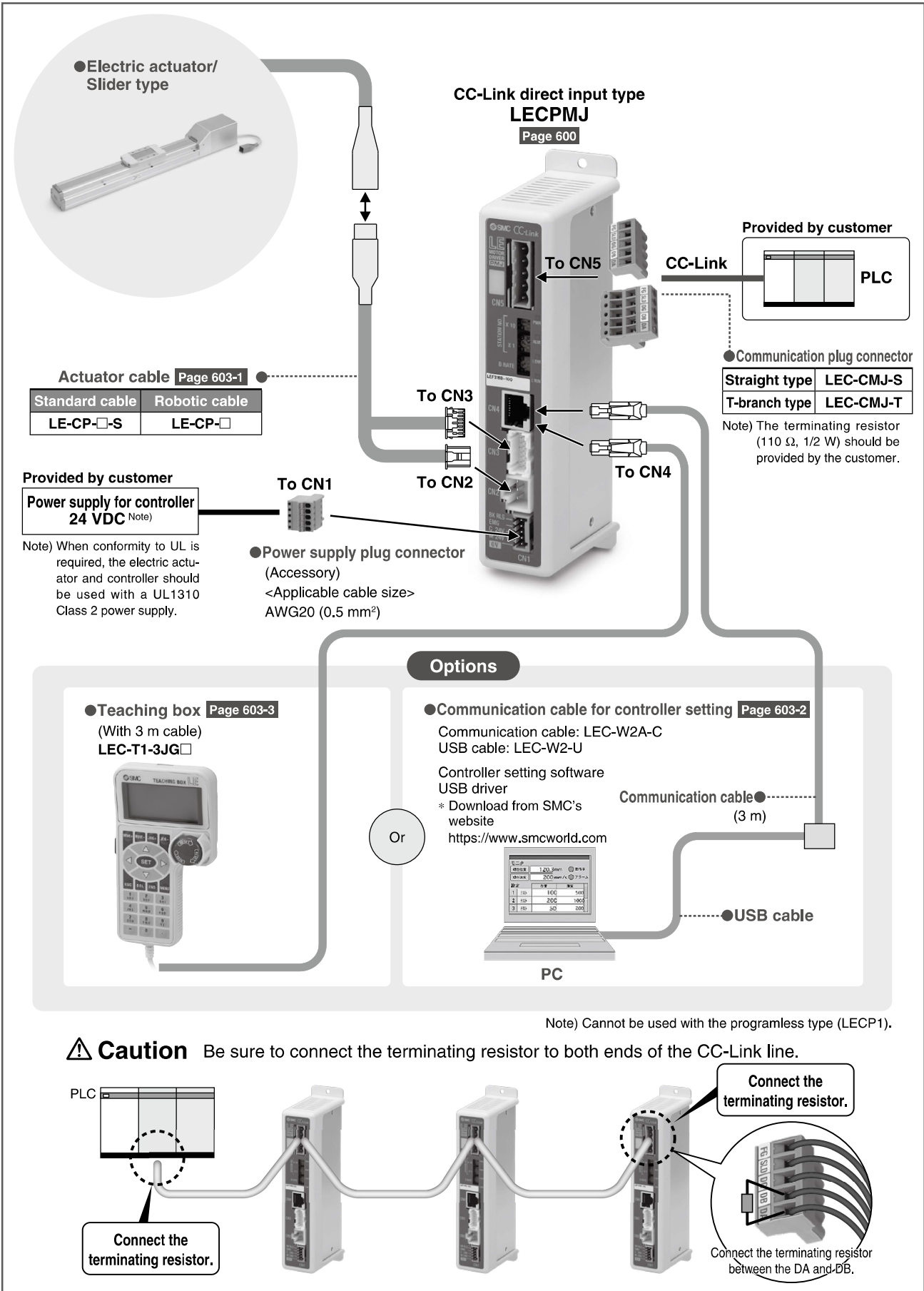

**Caution** Be sure to connect the terminating resistor to both ends of the CC-Link line.



# System Construction/Fieldbus Network (EtherCAT®/EtherNet/IP™/PROFINET/DeviceNet™/IO-Link Direct Input Type)

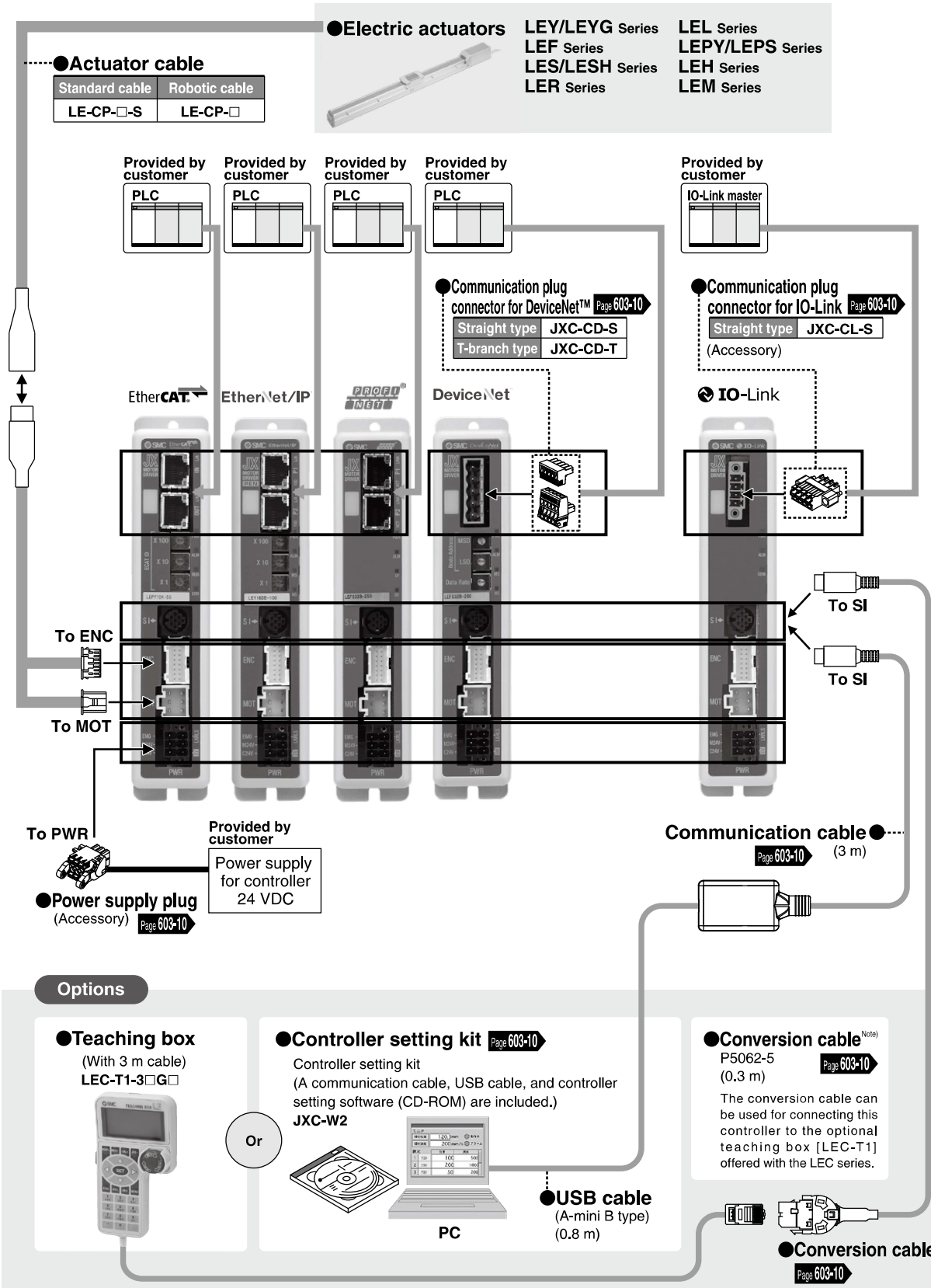

# System Construction/Fieldbus Network

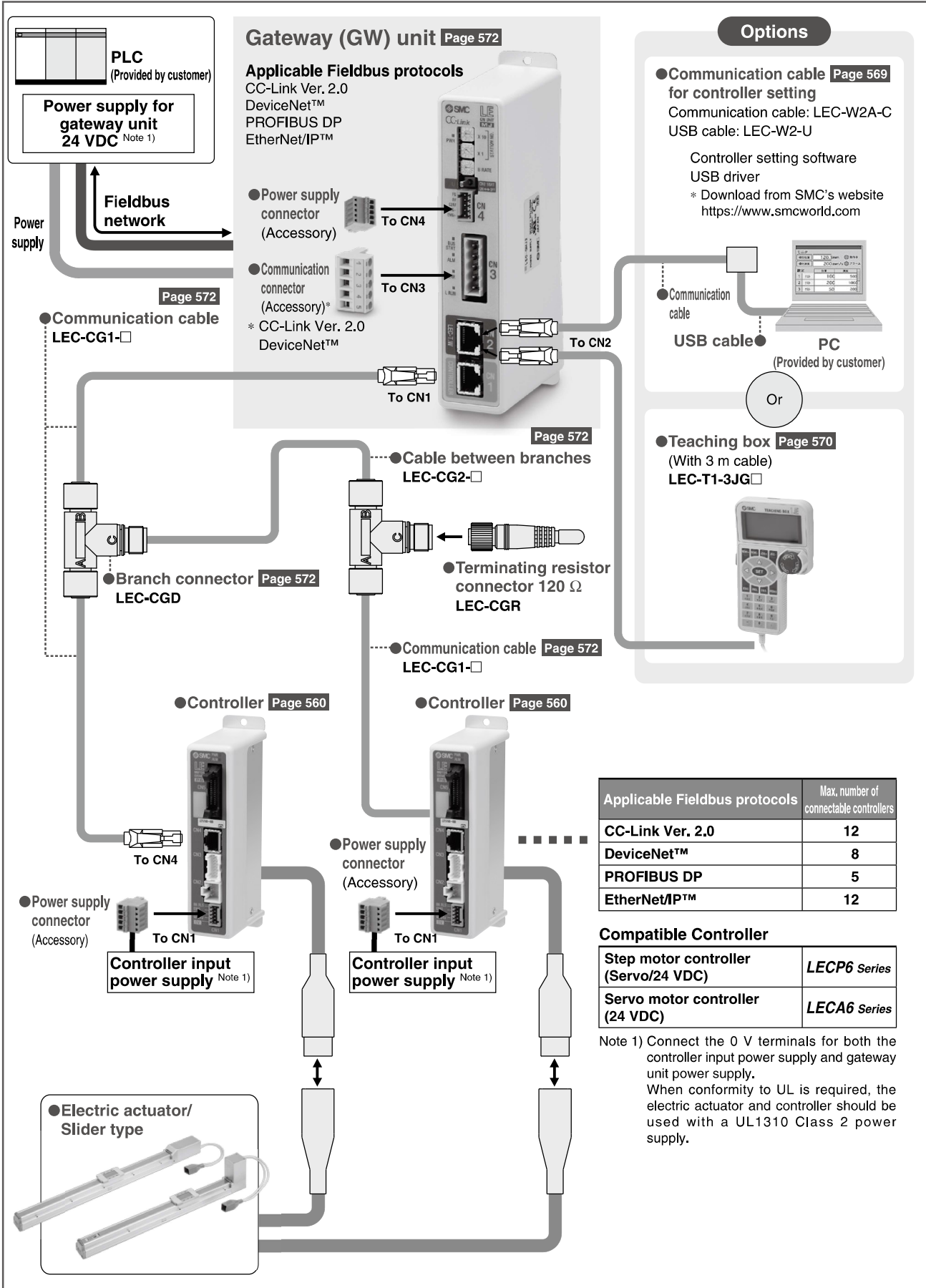

# System Construction/ EtherNet/IP™ Type (JXC92)

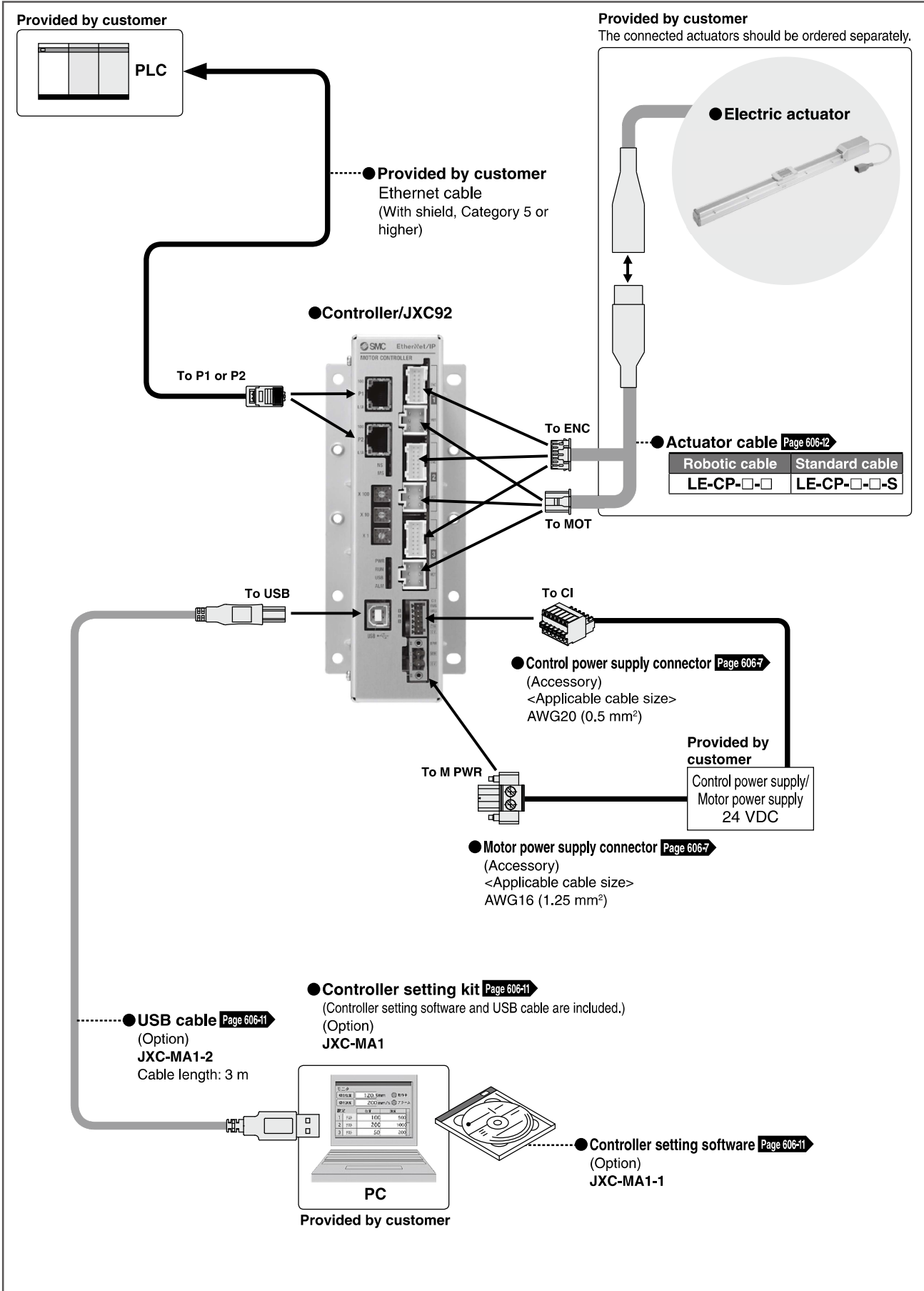

# System Construction/Parallel I/O (JXC73/83)

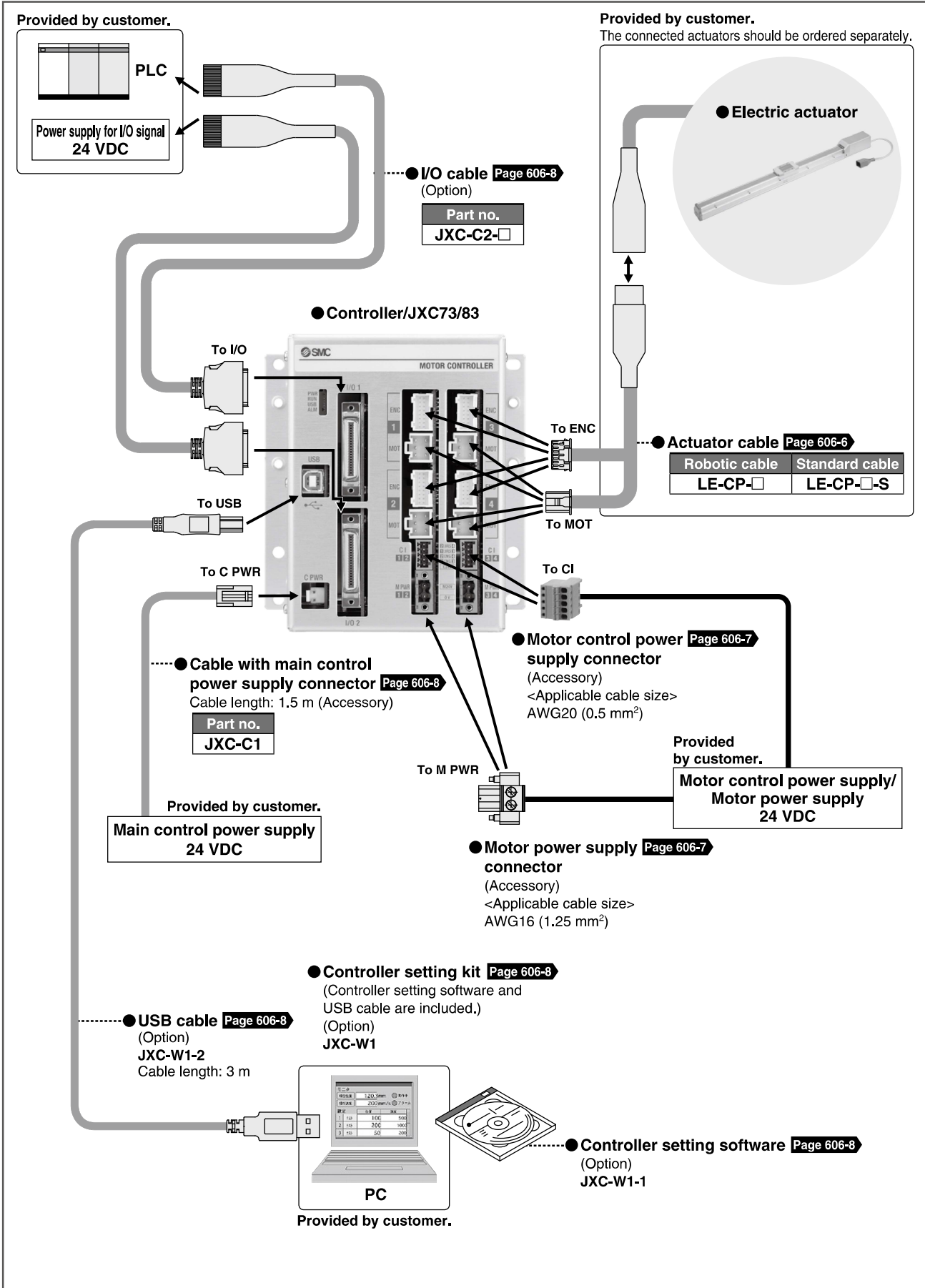

# System Construction/EtherNet/IP™ Type (JXC93)

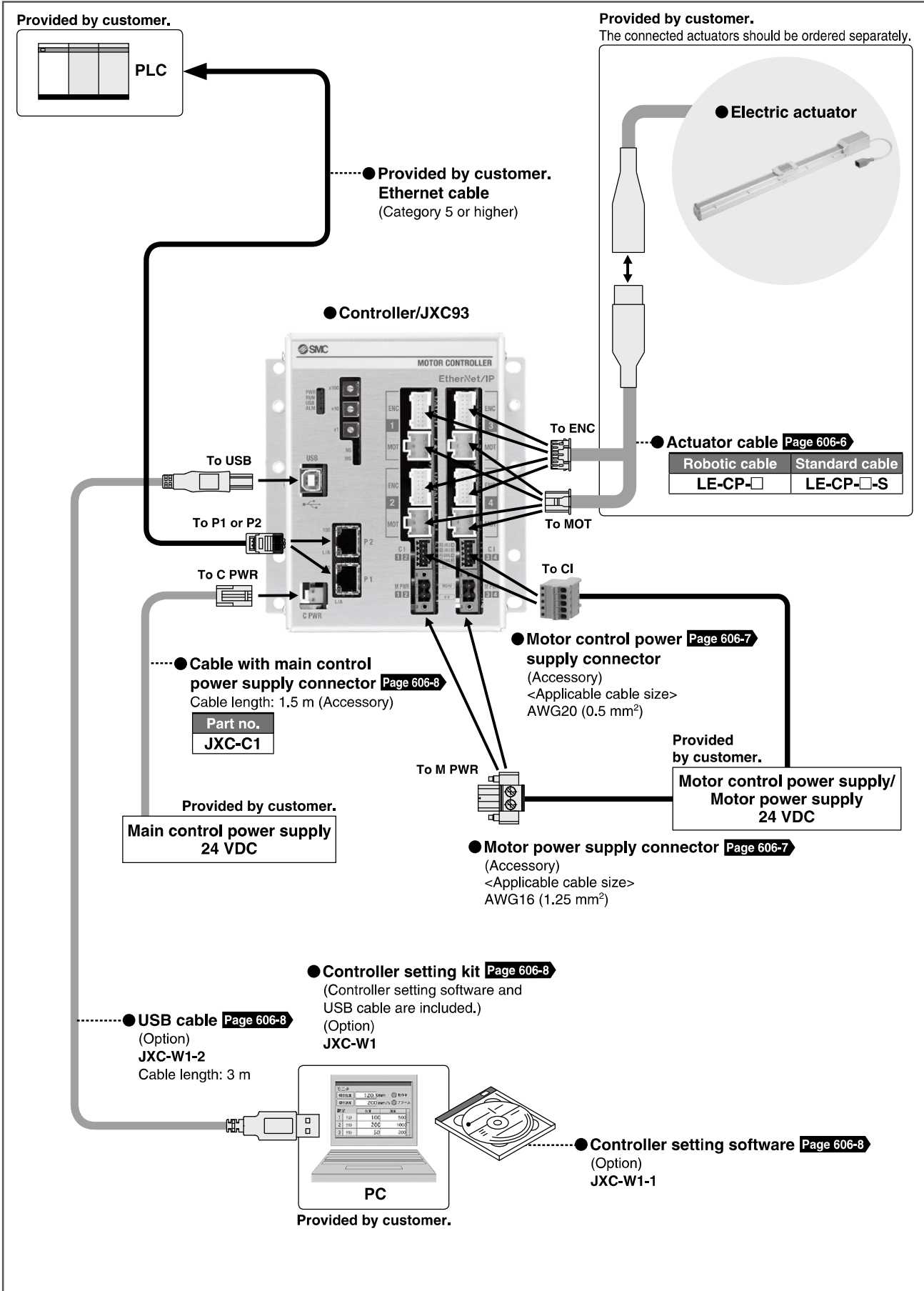

Compatible actuators



# Controller (Step Data Input Type) Step Motor (Servo/24 VDC)

LECP6 Series

# Servo Motor (24 VDC)

LECA6 Series



LECP6 Series LECA6 Series



## How to Order

### ⚠ Caution

#### [CE-compliant products]

- EMC compliance was tested by combining the electric actuator LE series and the controller LEC series. The EMC depends on the configuration of the customer's control panel and the relationship with other electrical equipment and wiring. Therefore, conformity to the EMC directive cannot be certified for SMC components incorporated into the customer's equipment under actual operating conditions. As a result, it is necessary for the customer to verify conformity to the EMC directive for the machinery and equipment as a whole.
- For the LECA6 series (servo motor controller), EMC compliance was tested by installing a noise filter set (LEC-NFA). Refer to page 568 for the noise filter set. Refer to the LECA Operation Manual for installation.

#### [UL-compliant products]

When conformity to UL is required, the electric actuator and controller should be used with a UL1310 Class 2 power supply.

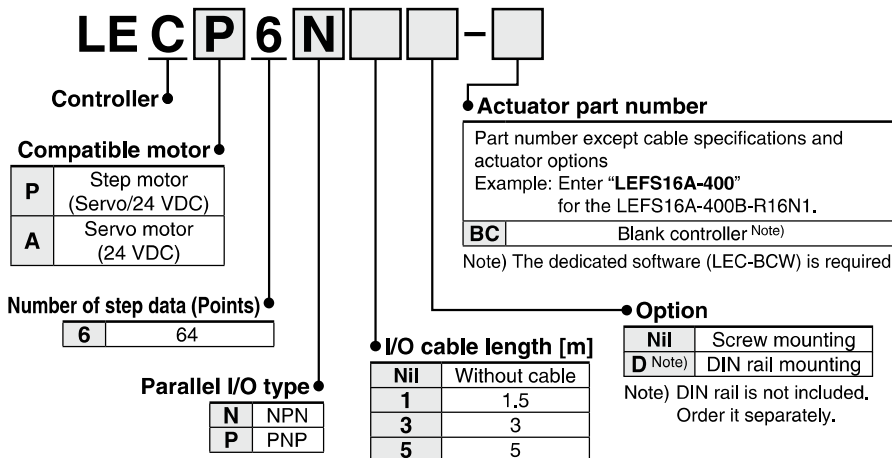

\* When controller equipped type is selected when ordering the LE series, you do not need to order this controller.

### The controller is sold as single unit after the compatible actuator is set.

Confirm that the combination of the controller and the actuator is correct.

#### <Check the following before use.>

- Check the actuator label for model number. This matches the controller.
- Check Parallel I/O configuration matches (NPN or PNP).

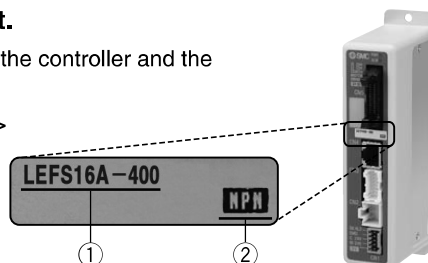

\* Refer to the operation manual for using the products. Please download it via our website, <http://www.smcworld.com>

### Precautions on blank controller (LEC□6□□-BC)

Blank controller is a controller to which the customer can write the data of the actuator to be combined and used. Use the dedicated software (LEC-BCW) for data writing.

- Please download the dedicated software (LEC-BCW) via our website.
- Order the communication cable for controller setting (LEC-W2A-C) separately to use this software.

SMC website

<https://www.smcworld.com>

## Specifications

### Basic Specifications

Item	LECP6	LECA6
Compatible motor	Step motor (Servo/24 VDC)	Servo motor (24 VDC)
Power supply <sup>Note 1)</sup>	Power voltage: 24 VDC ±10% <sup>Note 2)</sup> [Including motor drive power, control power, stop, lock release]	Power voltage: 24 VDC ±10% <sup>Note 2)</sup> [Including motor drive power, control power, stop, lock release]
Parallel input	11 inputs (Photo-coupler isolation)	
Parallel output	13 outputs (Photo-coupler isolation)	
Compatible encoder	Incremental A/B phase (800 pulse/rotation)	Incremental A/B (800 pulse/rotation)/Z phase
Serial communication	RS485 (Modbus protocol compliant)	
Memory	EEPROM	
LED indicator	LED (Green/Red) one of each	
Lock control	Forced-lock release terminal <sup>Note 3)</sup>	
Cable length [m]	I/O cable: 5 or less, Actuator cable: 20 or less	
Cooling system	Natural air cooling	
Operating temperature range [°C]	0 to 40 (No freezing)	
Operating humidity range [%RH]	90 or less (No condensation)	
Storage temperature range [°C]	-10 to 60 (No freezing)	
Storage humidity range [%RH]	90 or less (No condensation)	
Insulation resistance [MΩ]	Between the housing and SG terminal: 50 (500 VDC)	
Weight [g]	150 (Screw mounting), 170 (DIN rail mounting)	

Note 1) Do not use the power supply of "inrush current prevention type" for the controller power supply. When conformity to UL is required, the electric actuator and controller should be used with a UL1310 Class 2 power supply.

Note 2) The power consumption changes depending on the actuator model. Refer to the specifications of actuator for more details.

Note 3) Applicable to non-magnetizing lock.

## How to Mount

### a) Screw mounting (LEC□6□□-□) (Installation with two M4 screws)

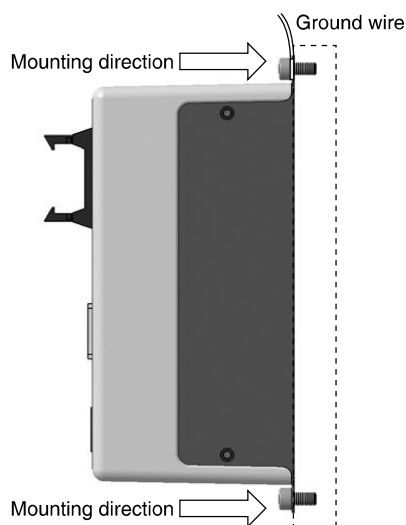

### b) DIN rail mounting (LEC□6□□D-□) (Installation with the DIN rail)

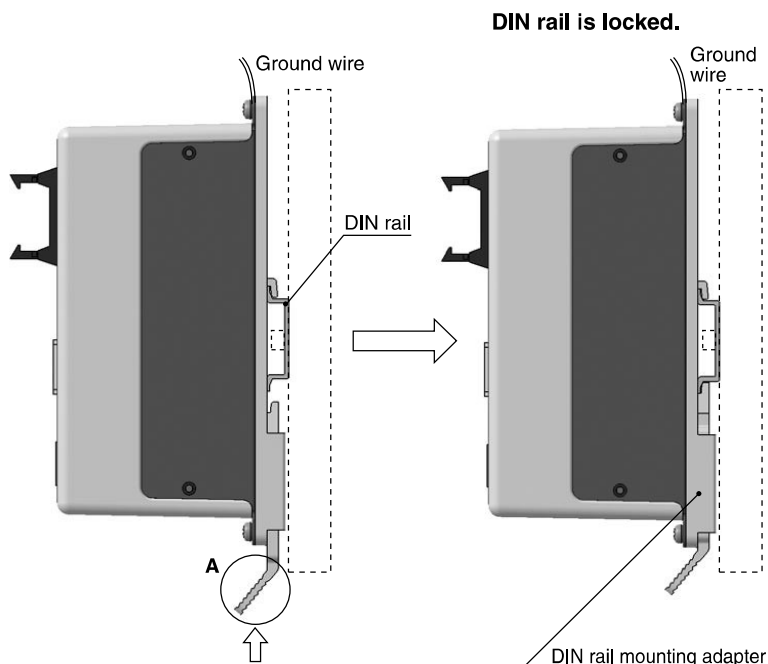

Hook the controller on the DIN rail and press the lever of section A in the arrow direction to lock it.

Note) When size 25 or more of the LE series are used, the space between the controllers should be 10 mm or more.

### DIN rail AXT100-DR-□

\* For □, enter a number from the "No." line in the table below.  
 Refer to the dimensions on page 562 for the mounting dimensions.

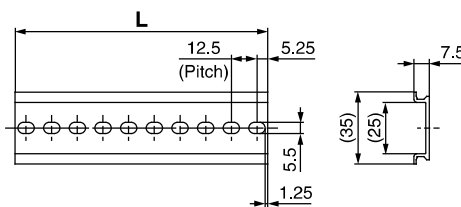

#### L Dimension [mm]

No.	1	2	3	4	5	6	7	8	9	10	11	12	13	14	15	16	17	18	19	20
L	23	35.5	48	60.5	73	85.5	98	110.5	123	135.5	148	160.5	173	185.5	198	210.5	223	235.5	248	260.5
No.	21	22	23	24	25	26	27	28	29	30	31	32	33	34	35	36	37	38	39	40
L	273	285.5	298	310.5	323	335.5	348	360.5	373	385.5	398	410.5	423	435.5	448	460.5	473	485.5	498	510.5

### DIN rail mounting adapter LEC-D0 (with 2 mounting screws)

This should be used when the DIN rail mounting adapter is mounted onto the screw mounting type controller afterwards.

# LECP6 Series LECA6 Series

## Dimensions

### a) Screw mounting (LEC□6□□-□)

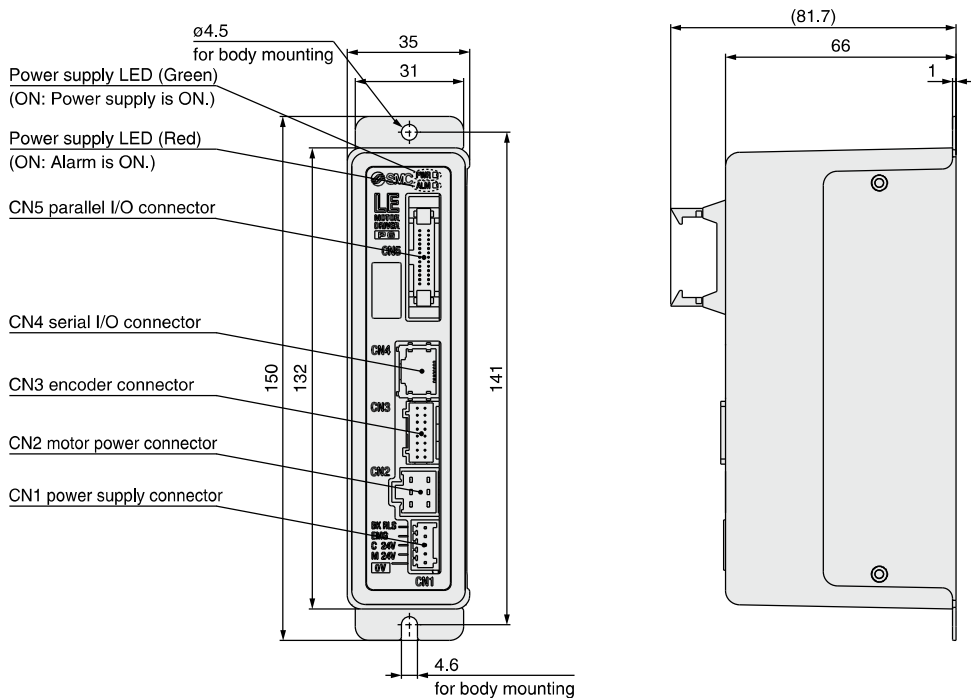

### b) DIN rail mounting (LEC□6□□D-□)

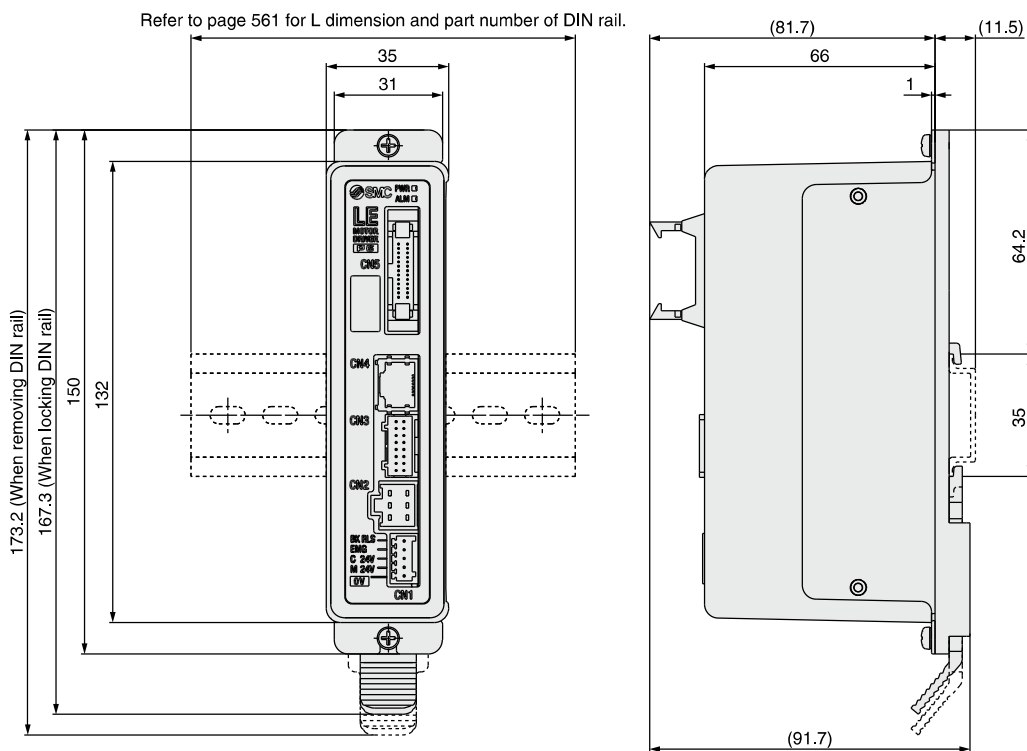

# Controller (Step Data Input Type)/Step Motor (Servo/24 VDC) **LECP6 Series** Controller (Step Data Input Type)/Servo Motor (24 VDC) **LECA6 Series**

## Wiring Example 1

### Power Supply Connector: CN1

\* Power supply plug is an accessory.  
<Applicable cable size> AWG20 (0.5 mm<sup>2</sup>), cover diameter 2.0 mm or less

#### CN1 Power Supply Connector Terminal for LECP6 (PHOENIX CONTACT FK-MC0.5/5-ST-2.5)

Terminal name	Function	Details
0V	Common supply (-)	M 24V terminal/C 24V terminal/EMG terminal/BK RLS terminal are common (-).
M 24V	Motor power supply (+)	Motor power supply (+) supplied to the controller
C 24V	Control power supply (+)	Control power supply (+) supplied to the controller
EMG	Stop (+)	Input (+) for releasing the stop
BK RLS	Lock release (+)	Input (+) for releasing the lock

#### Power supply plug for LECP6: LEC-D-1-1

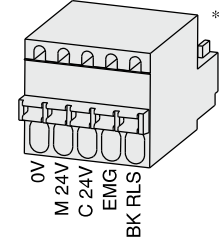

#### CN1 Power Supply Connector Terminal for LECA6 (PHOENIX CONTACT FK-MC0.5/7-ST-2.5)

Terminal name	Function	Details
0V	Common supply (-)	M 24V terminal/C 24V terminal/EMG terminal/BK RLS terminal are common (-).
M 24V	Motor power supply (+)	Motor power supply (+) supplied to the controller
C 24V	Control power supply (+)	Control power supply (+) supplied to the controller
EMG	Stop (+)	Input (+) for releasing the stop
BK RLS	Lock release (+)	Input (+) for releasing the lock
RG+	Regenerative output 1	Regenerative output terminals for external connection
RG-	Regenerative output 2	(Not necessary to connect them in the combination with the LE series standard specifications.)

#### Power supply plug for LECA6: LEC-D-1-2

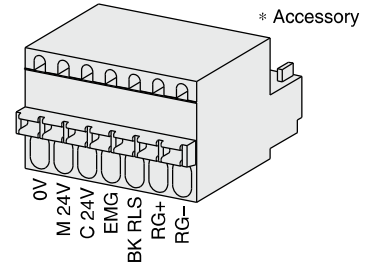

## Wiring Example 2

### Parallel I/O Connector: CN5

\* When you connect a PLC, etc., to the CN5 parallel I/O connector, please use the I/O cable (LEC-CN5-□).  
\* The wiring should be changed depending on the type of the parallel I/O (NPN or PNP).

#### Wiring diagram

#### LEC□6N□□□□ (NPN)

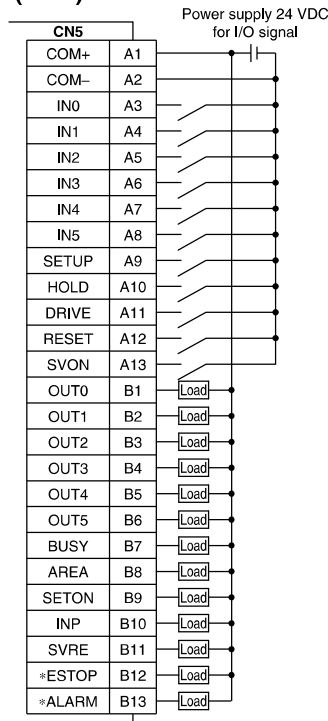

#### LEC□6P□□□□ (PNP)

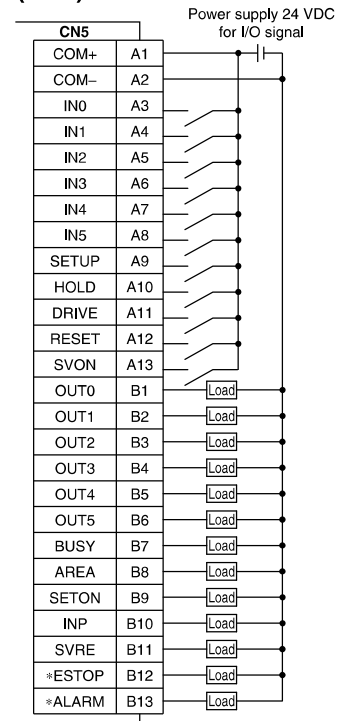

#### Input Signal

Name	Details
COM+	Connects the power supply 24 V for input/output signal
COM-	Connects the power supply 0 V for input/output signal
IN0 to IN5	Step data specified Bit No. (Input is instructed in the combination of IN0 to 5.)
SETUP	Instruction to return to origin
HOLD	Operation is temporarily stopped
DRIVE	Instruction to drive
RESET	Alarm reset and operation interruption
SVON	Servo ON instruction

#### Output Signal

Name	Details
OUT0 to OUT5	Outputs the step data no. during operation
BUSY	Outputs when the actuator is moving
AREA	Outputs within the step data area output setting range
SETON	Outputs when returning to origin
INP	Outputs when target position or target force is reached (Turns on when the positioning or pushing is completed.)
SVRE	Outputs when servo is on
*ESTOP (Note)	Not output when EMG stop is instructed
*ALARM (Note)	Not output when alarm is generated

Note) Signal of negative-logic circuit (N.C.)

# LECP6 Series

# LECA6 Series

## Step Data Setting

### 1. Step data setting for positioning

In this setting, the actuator moves toward and stops at the target position.

The following diagram shows the setting items and operation. The setting items and set values for this operation are stated below.

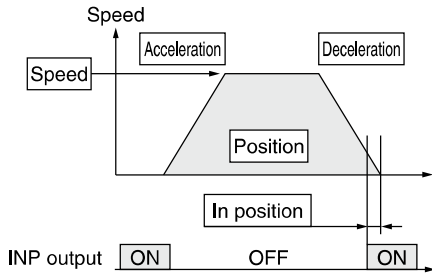

⊙: Need to be set.  
○: Need to be adjusted as required.  
—: Setting is not required.

#### Step Data (Positioning)

Necessity	Item	Details
⊙	Movement MOD	When the absolute position is required, set Absolute. When the relative position is required, set Relative.
⊙	Speed	Transfer speed to the target position
⊙	Position	Target position
○	Acceleration	Parameter which defines how rapidly the actuator reaches the speed set. The higher the set value, the faster it reaches the speed set.
○	Deceleration	Parameter which defines how rapidly the actuator comes to stop. The higher the set value, the quicker it stops.
⊙	Pushing force	Set 0. (If values 1 to 100 are set, the operation will be changed to the pushing operation.)
—	Trigger LV	Setting is not required.
—	Pushing speed	Setting is not required.
○	Moving force	Max. torque during the positioning operation (No specific change is required.)
○	Area 1, Area 2	Condition that turns on the AREA output signal.
○	In position	Condition that turns on the INP output signal. When the actuator enters the range of [in position], the INP output signal turns on. (It is unnecessary to change this from the initial value.) When it is necessary to output the arrival signal before the operation is completed, make the value larger.

### 2. Step data setting for pushing

The actuator moves toward the pushing start position, and when it reaches that position, it starts pushing with the set force or less.

The following diagram shows the setting items and operation. The setting items and set values for this operation are stated below.

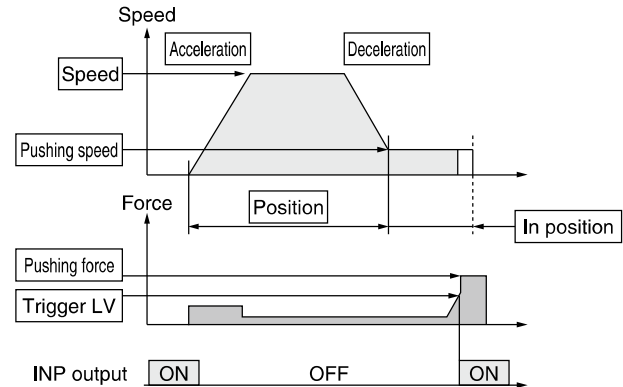

⊙: Need to be set.  
○: Need to be adjusted as required.

#### Step Data (Pushing)

Necessity	Item	Details
⊙	Movement MOD	When the absolute position is required, set Absolute. When the relative position is required, set Relative.
⊙	Speed	Transfer speed to the pushing start position
⊙	Position	Pushing start position
○	Acceleration	Parameter which defines how rapidly the actuator reaches the speed set. The higher the set value, the faster it reaches the speed set.
○	Deceleration	Parameter which defines how rapidly the actuator comes to stop. The higher the set value, the quicker it stops.
⊙	Pushing force	Pushing force ratio is defined. The setting range differs depending on the electric actuator type. Refer to the operation manual for the electric actuator.
⊙	Trigger LV	Condition that turns on the INP output signal. The INP output signal turns on when the generated force exceeds the value. Trigger level should be the pushing force or less.
○	Pushing speed	Pushing speed during pushing. When the speed is set fast, the electric actuator and workpieces might be damaged due to the impact when they hit the end, so this set value should be smaller. Refer to the operation manual for the electric actuator.
○	Moving force	Max. torque during the positioning operation (No specific change is required.)
○	Area 1, Area 2	Condition that turns on the AREA output signal.
⊙	In position	Transfer distance during pushing. If the transferred distance exceeds the setting, it stops even if it is not pushing. If the transfer distance is exceeded, the INP output signal will not turn on.

## Signal Timing

### Return to Origin

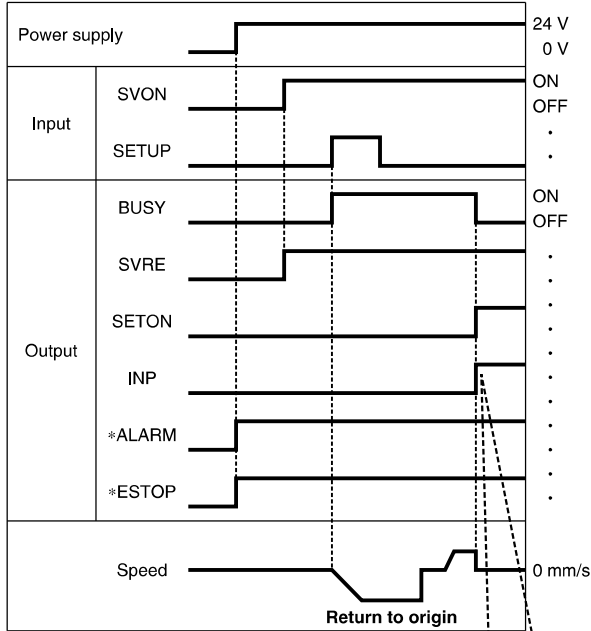

If the actuator is within the "In position" range of the basic parameter, INP will turn ON, but if not, it will remain OFF.

\* \*ALARM" and \*ESTOP" are expressed as negative-logic circuit.

### Positioning Operation

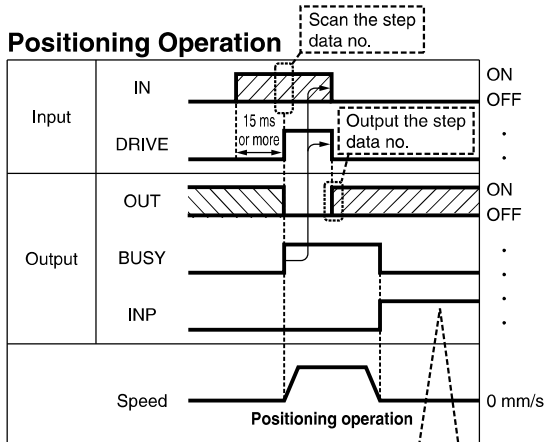

If the actuator is within the "In position" range of the step data, INP will turn ON, but if not, it will remain OFF.

\* "OUT" is output when "DRIVE" is changed from ON to OFF.  
 Refer to the operation manual for details on the controller for the LEM series.  
 (When power supply is applied, "DRIVE" or "RESET" is turned ON or  
 \*ESTOP" is turned OFF, all of the "OUT" outputs are OFF.)

### Pushing Operation

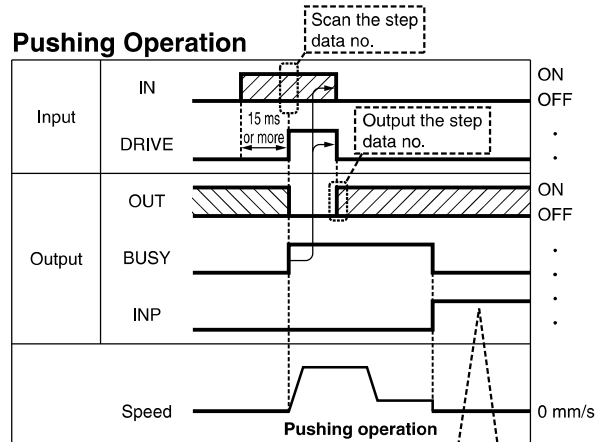

If the current pushing force exceeds the "Trigger LV" value of the step data, INP signal will turn ON.

### HOLD

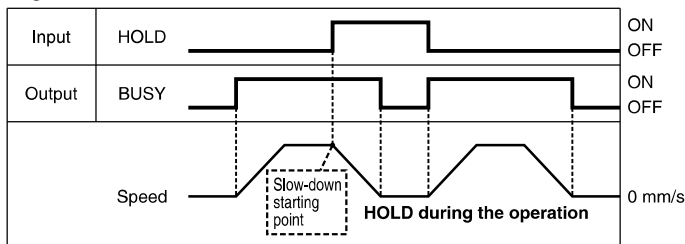

\* When the actuator is within the "In position" range in the pushing operation, it does not stop even if HOLD signal is input.

### Reset

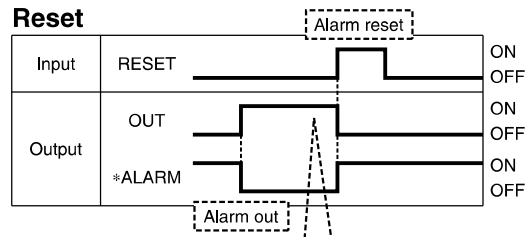

It is possible to identify the alarm group by the combination of OUT signals when the alarm is generated.

\* \*ALARM" is expressed as negative-logic circuit.

# LECP6 Series LECA6 Series

## Options: Actuator Cable

[Robotic cable, standard cable for step motor (Servo/24 VDC)]

LE-CP-1-□

Cable length (L) [m]

1	1.5
3	3
5	5
8	8*
A	10*
B	15*
C	20*

\* Produced upon receipt of order (Robotic cable only)

Cable type

Nil	Robotic cable (Flexible cable)
S	Standard cable

### Weight

Product no.	Weight [g]	Note
LE-CP-1-S	190	Standard cable
LE-CP-3-S	280	
LE-CP-5-S	460	
LE-CP-1	140	Robotic cable
LE-CP-3	260	
LE-CP-5	420	
LE-CP-8	790	
LE-CP-A	980	
LE-CP-B	1460	
LE-CP-C	1940	

LE-CP- $\frac{1}{5}$ /Cable length: 1.5 m, 3 m, 5 m

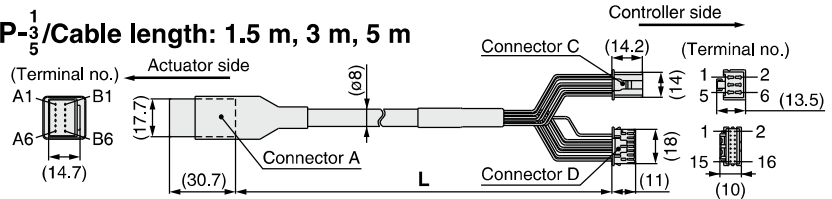

LE-CP- $\frac{8}{A/C}$ /Cable length: 8 m, 10 m, 15 m, 20 m  
(\* Produced upon receipt of order)

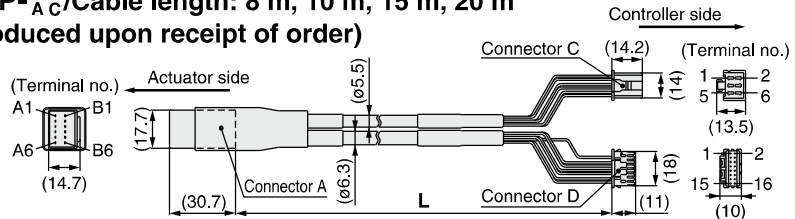

Signal	Connector A terminal no.	Cable color	Connector C terminal no.
A	B-1	Brown	2
A	A-1	Red	1
B	B-2	Orange	6
B	A-2	Yellow	5
COM-A/COM	B-3	Green	3
COM-B/-	A-3	Blue	4
Shield			
Vcc	B-4	Brown	12
GND	A-4	Black	13
A	B-5	Red	7
A	A-5	Black	6
B	B-6	Orange	9
B	A-6	Black	8
		-	3

[Robotic cable, standard cable with lock and sensor for step motor (Servo/24 VDC)]

LE-CP-1-B-□

Cable length (L) [m]

1	1.5
3	3
5	5
8	8*
A	10*
B	15*
C	20*

\* Produced upon receipt of order (Robotic cable only)

With lock and sensor

Cable type

Nil	Robotic cable (Flexible cable)
S	Standard cable

### Weight

Product no.	Weight [g]	Note
LE-CP-1-B-S	240	Standard cable
LE-CP-3-B-S	380	
LE-CP-5-B-S	630	
LE-CP-1-B	190	Robotic cable
LE-CP-3-B	360	
LE-CP-5-B	590	
LE-CP-8-B	1060	
LE-CP-A-B	1320	
LE-CP-B-B	1920	
LE-CP-C-B	2620	

LE-CP- $\frac{1}{5}$ /Cable length: 1.5 m, 3 m, 5 m

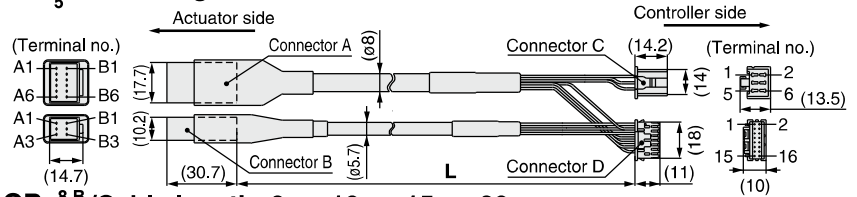

LE-CP- $\frac{8}{A/C}$ /Cable length: 8 m, 10 m, 15 m, 20 m  
(\* Produced upon receipt of order)

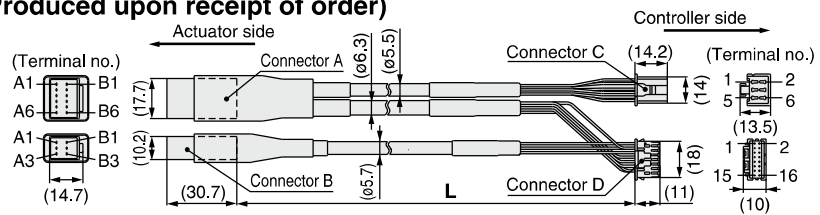

Signal	Connector A terminal no.	Cable color	Connector C terminal no.
A	B-1	Brown	2
A	A-1	Red	1
B	B-2	Orange	6
B	A-2	Yellow	5
COM-A/COM	B-3	Green	3
COM-B/-	A-3	Blue	4
Shield			
Vcc	B-4	Brown	12
GND	A-4	Black	13
A	B-5	Red	7
A	A-5	Black	6
B	B-6	Orange	9
B	A-6	Black	8
		-	3

Signal	Connector B terminal no.	Cable color	Connector D terminal no.
Lock (+)	B-1	Red	4
Lock (-)	A-1	Black	5
Sensor (+)	B-3	Brown	1
Sensor (-)	A-3	Blue	2

Controller (Step Data Input Type)/Step Motor (Servo/24 VDC) **LECP6 Series**  
 Controller (Step Data Input Type)/Servo Motor (24 VDC) **LECA6 Series**

[Robotic cable for servo motor (24 VDC)]

**LE-CA-1**

Cable length (L) [m]

1	1.5
3	3
5	5
8	8*
A	10*
B	15*
C	20*

\* Produced upon receipt of order

Weight

Product no.	Weight [g]
LE-CA-1	220
LE-CA-3	420
LE-CA-5	700
LE-CA-8	1100
LE-CA-A	1370
LE-CA-B	2050
LE-CA-C	2720

LE-CA-□

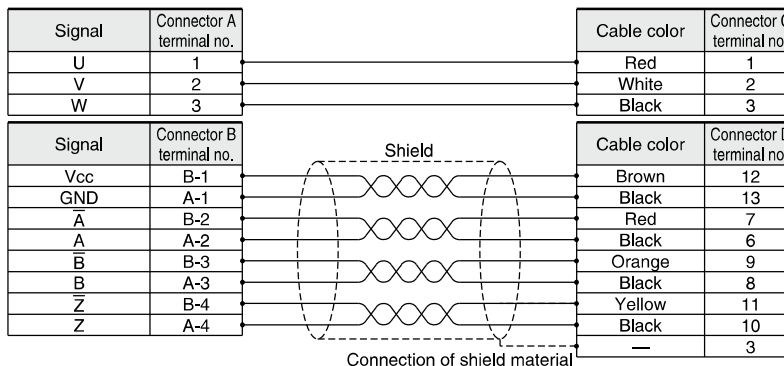
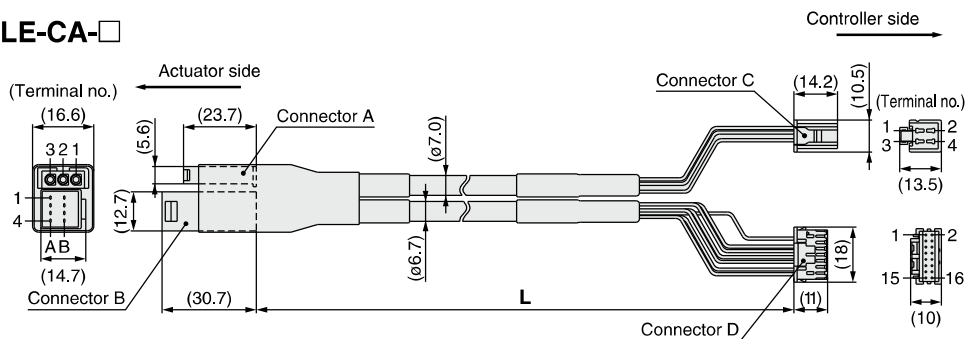

[Robotic cable with lock and sensor for servo motor (24 VDC)]

**LE-CA-1-B**

Cable length (L) [m]

1	1.5
3	3
5	5
8	8*
A	10*
B	15*
C	20*

\* Produced upon receipt of order

With lock and sensor

Weight

Product no.	Weight [g]
LE-CA-1-B	270
LE-CA-3-B	520
LE-CA-5-B	870
LE-CA-8-B	1370
LE-CA-A-B	1710
LE-CA-B-B	2560
LE-CA-C-B	3400

LE-CA-□-B

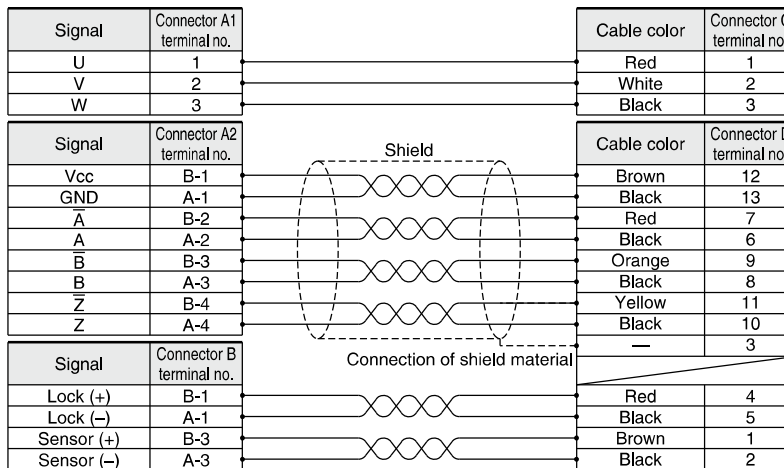
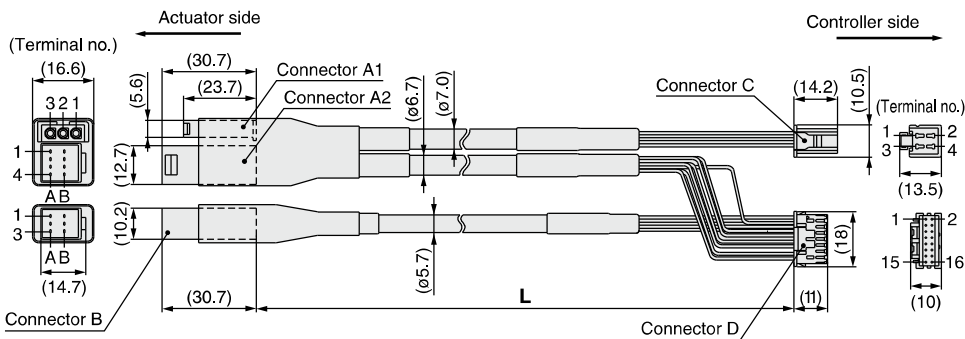

# LECP6 Series LECA6 Series

## Option: I/O Cable

### LEC-CN5-1

Cable length (L) [m]

1	1.5
3	3
5	5

\* Conductor size: AWG28

#### Weight

Product no.	Weight [g]
LEC-CN5-1	170
LEC-CN5-3	320
LEC-CN5-5	520

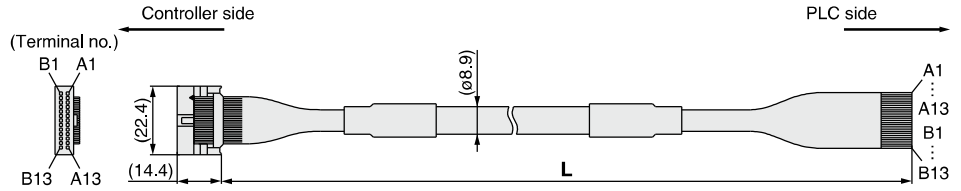

Connector pin no.	Insulation color	Dot mark	Dot color
A1	Light brown	■	Black
A2	Light brown	■	Red
A3	Yellow	■	Black
A4	Yellow	■	Red
A5	Light green	■	Black
A6	Light green	■	Red
A7	Gray	■	Black
A8	Gray	■	Red
A9	White	■	Black
A10	White	■	Red
A11	Light brown	■ ■	Black
A12	Light brown	■ ■	Red
A13	Yellow	■ ■	Black

Connector pin no.	Insulation color	Dot mark	Dot color
B1	Yellow	■ ■	Red
B2	Light green	■ ■	Black
B3	Light green	■ ■	Red
B4	Gray	■ ■	Black
B5	Gray	■ ■	Red
B6	White	■ ■	Black
B7	White	■ ■	Red
B8	Light brown	■ ■ ■	Black
B9	Light brown	■ ■ ■	Red
B10	Yellow	■ ■ ■	Black
B11	Yellow	■ ■ ■	Red
B12	Light green	■ ■ ■	Black
B13	Light green	■ ■ ■	Red
—			Shield

## Option: Noise Filter Set for Servo Motor (24 VDC)

### LEC-NFA

Contents of the set: 2 noise filters (Manufactured by WURTH ELEKTRONIK: 74271222)

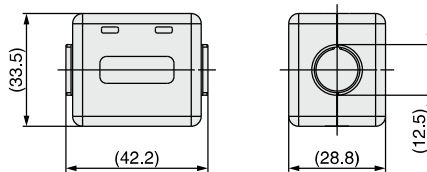

\* Refer to the LECA6 series Operation Manual for installation.

# LEC Series

# Communication Cable for Controller Setting/LEC-W2A-□

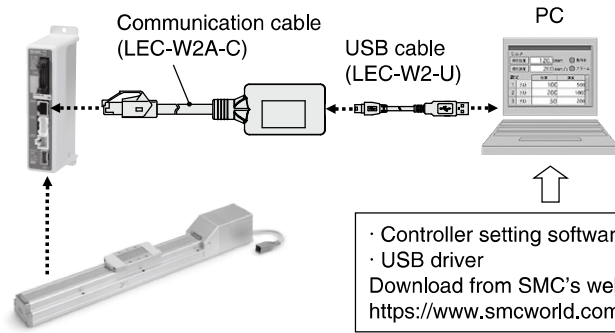

## How to Order

**LEC-W2A-C**

Communication cable

**LEC-W2-U**

USB cable

## Compatible Controller/Driver

Step data input type	LECP6 Series/LECA6 Series
Pulse input type	LECPA Series
CC-Link direct input type	LECPMJ Series
Step Motor Controller	JXCE1/91/P1/D1/L1 Series

\* When connecting to a JXCE1/91/P1/D1/L1 series product, use a conversion cable (P5062-5) as a relay.

## Hardware Requirements

OS	Windows®7, Windows®8.1, Windows®10
Communication interface	USB 1.1 or USB 2.0 ports
Display	1024 x 768 or more

\* Windows®7, Windows®8.1 and Windows®10 are registered trademarks of Microsoft Corporation in the United States.

## Screen Example

### Easy mode screen example

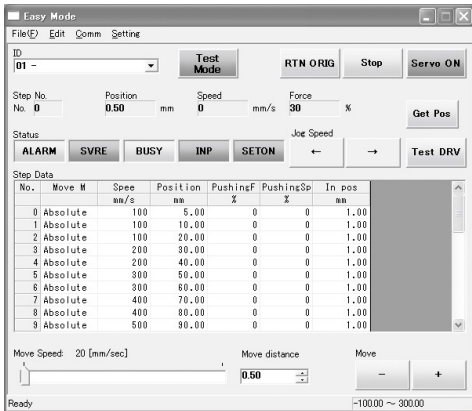

### Easy operation and simple setting

- Allowing to set and display actuator step data such as position, speed, force, etc.
- Setting of step data and test drive can be performed on the same page.
- Can be used to jog and move at a constant rate.

### Normal mode screen example

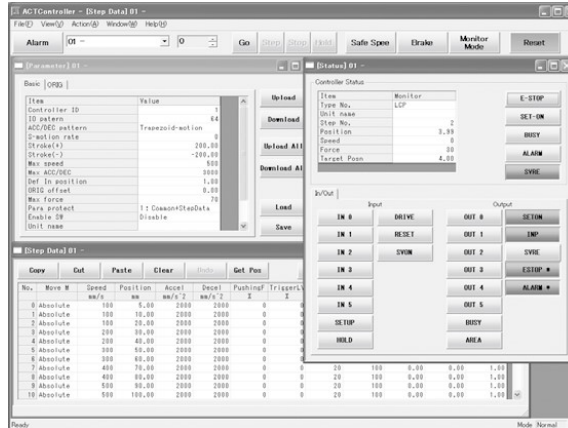

### Detailed setting

- Step data can be set in detail.
- Signals and terminal status can be monitored.
- Parameters can be set.
- JOG and constant rate movement, return to origin, test drive and testing of forced output can be performed.

## How to Order



LEC-T1-3 J G

Teaching box

Enable switch

Cable length [m]	3
------------------	---

Nil	None
S	Equipped with enable switch

\* Interlock switch for jog and test function

Initial language

J	Japanese
E	English

Stop switch

G	Equipped with stop switch
---	---------------------------

\* The displayed language can be changed to English or Japanese.

## Specifications

Item	Description
Switch	Stop switch, Enable switch (Option)
Cable length [m]	3
Enclosure	IP64 (Except connector)
Operating temperature range [°C]	5 to 50
Operating humidity range [%RH]	90 or less (No condensation)
Weight [g]	350 (Except cable)

### [CE-compliant products]

The EMC compliance of the teaching box was tested with the LECP6 series step motor controller (servo/24 VDC) and an applicable actuator.

### [UL-compliant products]

When conformity to UL is required, the electric actuator and controller should be used with a UL1310 Class 2 power supply.

### Standard functions

- Chinese character display
- Stop switch is provided.

### Option

- Enable switch is provided.

## Easy Mode

Function	Details
Step data	• Setting of step data
Jog	• Jog operation • Return to origin
Test	• 1 step operation • Return to origin
Monitor	• Display of axis and step data no. • Display of two items selected from Position, Speed, Force.
ALM	• Active alarm display • Alarm reset
TB setting	• Reconnection of axis (Ver. 1.**) • Displayed language setting (Ver. 2.**) • Setting of easy/normal mode • Setting step data and selection of items from easy mode monitor

### Menu Operations Flowchart

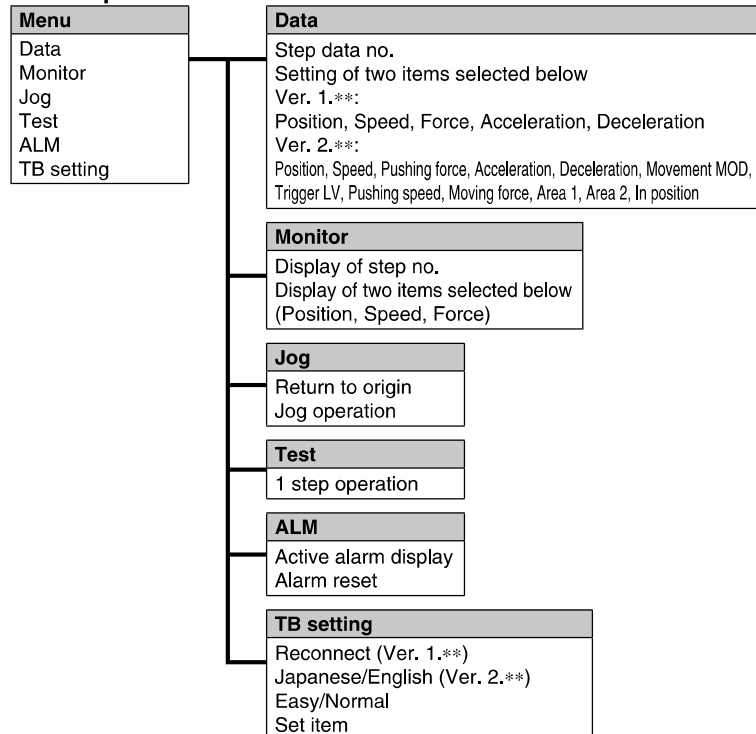

## Normal Mode

Function	Details
Step data	• Step data setting
Parameter	• Parameters setting
Test	<ul style="list-style-type: none"> <li>• Jog operation/Constant rate movement</li> <li>• Return to origin</li> <li>• Test drive (Specify a maximum of 5 step data and operate.)</li> <li>• Forced output (Forced signal output, Forced terminal output)</li> </ul>
Monitor	<ul style="list-style-type: none"> <li>• Drive monitor</li> <li>• Output signal monitor</li> <li>• Input signal monitor</li> <li>• Output terminal monitor</li> <li>• Input terminal monitor</li> </ul>
ALM	<ul style="list-style-type: none"> <li>• Active alarm display (Alarm reset)</li> <li>• Alarm log record display</li> </ul>
File	<ul style="list-style-type: none"> <li>• Data saving Save the step data and parameters of the controller which is being used for communication (it is possible to save four files, with one set of step data and parameters defined as one file).</li> <li>• Load to controller Loads the data which is saved in the teaching box to the controller which is being used for communication.</li> <li>• Delete the saved data.</li> <li>• File protection (Ver. 2.**)</li> </ul>
TB setting	<ul style="list-style-type: none"> <li>• Display setting (Easy/Normal mode)</li> <li>• Language setting (Japanese/English)</li> <li>• Backlight setting</li> <li>• LCD contrast setting</li> <li>• Beep sound setting</li> <li>• Max. connection axis</li> <li>• Distance unit (mm/inch)</li> </ul>
Reconnect	• Reconnection of axis

## Menu Operations Flowchart

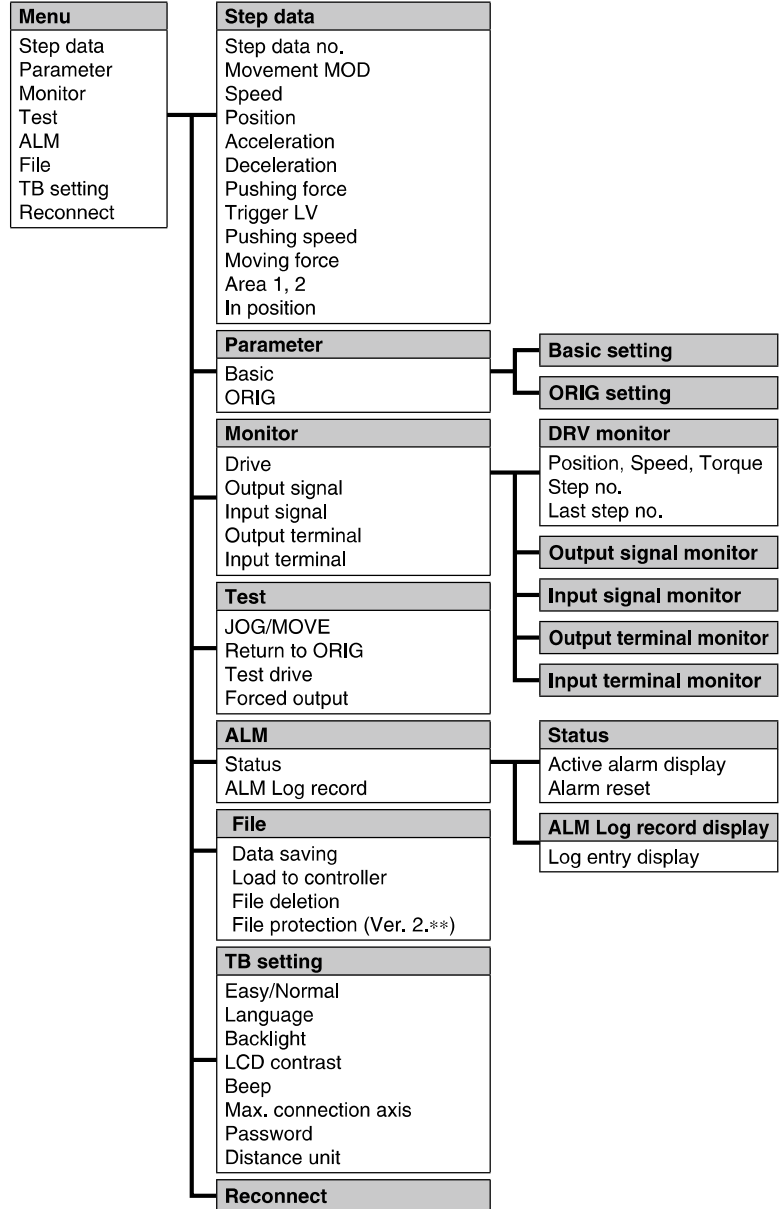

## Dimensions

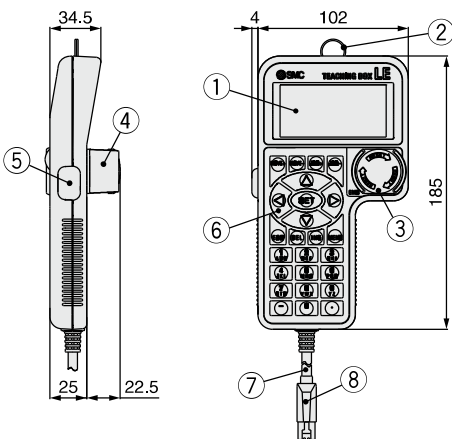

No.	Description	Function
1	<b>LCD</b>	A screen of liquid crystal display (with backlight)
2	<b>Ring</b>	A ring for hanging the teaching box
3	<b>Stop switch</b>	When switch is pushed in, the switch locks and stops. The lock is released when it is turned to the right.
4	<b>Stop switch guard</b>	A guard for the stop switch
5	<b>Enable switch (Option)</b>	Prevents unintentional operation (unexpected operation) of the jog test function. Other functions such as data change are not covered.
6	<b>Key switch</b>	Switch for each input
7	<b>Cable</b>	Length: 3 meters
8	<b>Connector</b>	A connector connected to CN4 of the controller

# Gateway Unit

## LEC-G Series



### How to Order

#### ⚠ Caution

**[CE-compliant products]**  
EMC compliance was tested by combining the electric actuator LE series and the controller LEC series. The EMC depends on the configuration of the customer's control panel and the relationship with other electrical equipment and wiring. Therefore, conformity to the EMC directive cannot be certified for SMC components incorporated into the customer's equipment under actual operating conditions. As a result, it is necessary for the customer to verify conformity to the EMC directive for the machinery and equipment as a whole.

**[UL-compliant products]**  
When conformity to UL is required, the electric actuator and controller should be used with a UL1310 Class 2 power supply.

#### Gateway unit LEC-G MJ2

**Applicable Fieldbus protocols**

<b>MJ2</b>	CC-Link Ver. 2.0
<b>DN1</b>	DeviceNet™
<b>PR1</b>	PROFIBUS DP
<b>EN1</b>	EtherNet/IP™

**Mounting**

<b>Nil</b>	Screw mounting
<b>D</b> (Note)	DIN rail mounting

Note) DIN rail is not included. Order it separately.



#### Cable LEC-CG 1-L

**Cable type**

<b>1</b>	Communication cable
<b>2</b>	Cable between branches

**Cable length**

<b>K</b>	0.3 m
<b>L</b>	0.5 m
<b>1</b>	1 m

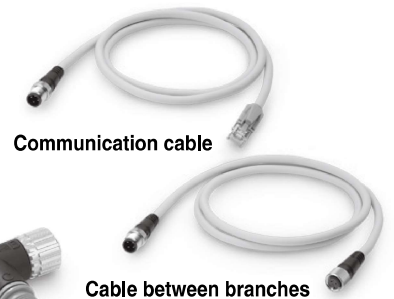

#### Branch connector LEC-CGD

Branch connector

#### Terminating resistor LEC-CGR

### Specifications

Model		LEC-GMJ2	LEC-GDN1	LEC-GPR1	LEC-GEN1	
<b>Communication specifications</b>	<b>Applicable system</b>	CC-Link	DeviceNet™	PROFIBUS DP	EtherNet/IP™	
	<b>Fieldbus Version</b> (Note 1)	Ver. 2.0	Release 2.0	V1	Release 1.0	
	<b>Communication speed [bps]</b>	156 k/625 k/2.5 M /5 M/10 M	125 k/250 k/500 k	9.6 k/19.2 k/45.45 k/ 93.75 k/187.5 k/500 k/ 1.5 M/3 M/6 M/12 M	10 M/100 M	
	<b>Configuration file</b> (Note 2)	—	EDS file	GSD file	EDS file	
	<b>I/O occupation area</b>	4 stations occupied (8 times setting)	Input 896 points 108 words Output 896 points 108 words	Input 200 bytes Output 200 bytes	Input 57 words Output 57 words	Input 256 bytes Output 256 bytes
	<b>Power supply for communication</b>	<b>Power supply voltage [V]</b> (Note 3)	—	11 to 25 VDC	—	—
		<b>Internal current consumption [mA]</b>	—	100	—	—
	<b>Communication connector specifications</b>		Connector (Accessory)	Connector (Accessory)	D-sub	RJ45
<b>Terminating resistor</b>		Not included	Not included	Not included	Not included	
<b>Power supply voltage [V]</b> (Note 6)		24 VDC ±10%				
<b>Current consumption [mA]</b>	<b>Not connected to teaching box</b>	200				
	<b>Connected to teaching box</b>	300				
<b>EMG output terminal</b>		30 VDC 1 A				
<b>Controller specifications</b>	<b>Applicable controllers</b>	LECP6 Series, LECA6 Series				
	<b>Communication speed [bps]</b> (Note 3)	115.2 k/230.4 k				
	<b>Max. number of connectable controllers</b> (Note 4)	12	8 (Note 5)	5	12	
<b>Accessories</b>		Power supply connector, communication connector		Power supply connector		
<b>Operating temperature range [°C]</b>		0 to 40 (No freezing)				
<b>Operating humidity range [%RH]</b>		90 or less (No condensation)				
<b>Storage temperature range [°C]</b>		-10 to 60 (No freezing)				
<b>Storage humidity range [%RH]</b>		90 or less (No condensation)				
<b>Weight [g]</b>		200 (Screw mounting), 220 (DIN rail mounting)				

Note 1) Please note that the version is subject to change.

Note 2) Each file can be downloaded from the SMC website, <http://www.smcworld.com>

Note 3) When using a teaching box (LEC-T1-□), set the communication speed to 115.2 kbps.

Note 4) A communication response time for 1 controller is approximately 30 ms.

Refer to "Communication Response Time Guideline" for response times when several controllers are connected.

Note 5) For step data input, up to 12 controllers connectable.

Note 6) When conformity to UL is required, the electric actuator and controller should be used with a UL1310 Class 2 power supply.

## Communication Response Time Guideline

Response time between gateway unit and controllers depends on the number of controllers connected to the gateway unit. For response time, refer to the graph below.

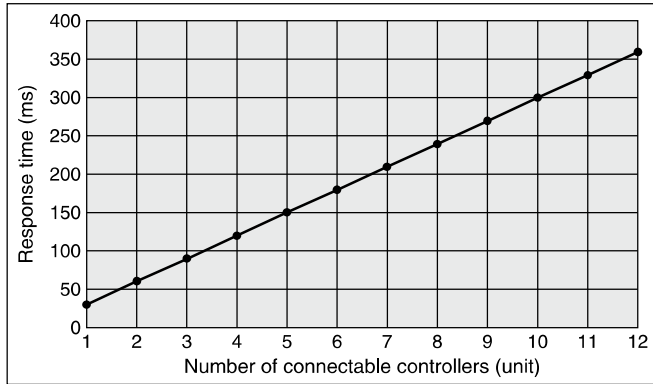

\* This graph shows delay times between gateway unit and controllers. Fieldbus network delay time is not included.

## Dimensions

### Screw mounting (LEC-G□□□□)

Applicable Fieldbus protocol: CC-Link Ver. 2.0

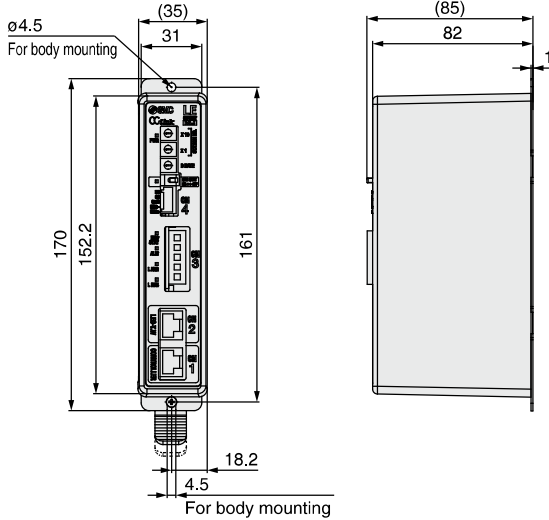

Applicable Fieldbus protocol: DeviceNet™

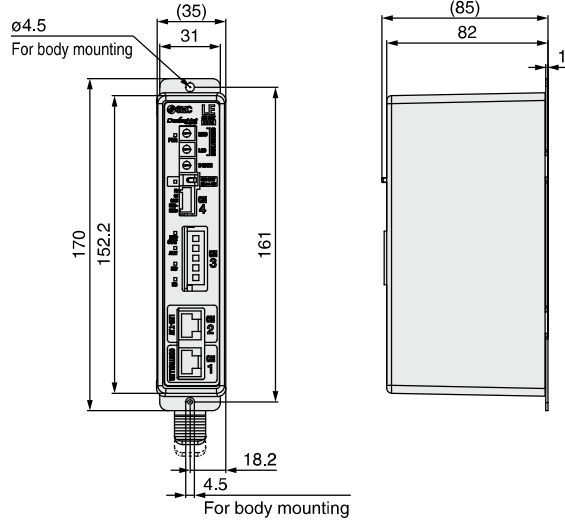

Applicable Fieldbus protocol: PROFIBUS DP

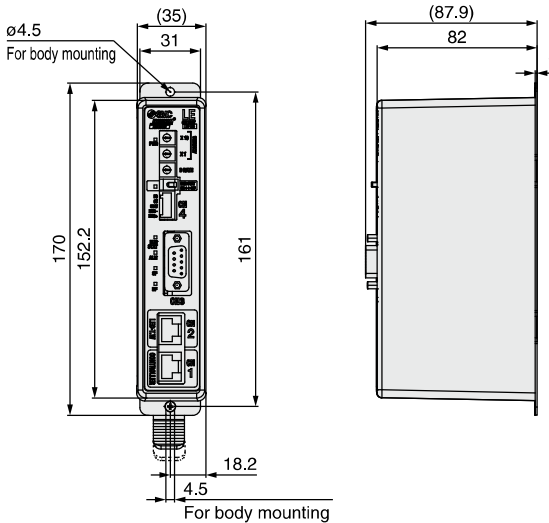

Applicable Fieldbus protocol: EtherNet/IP™

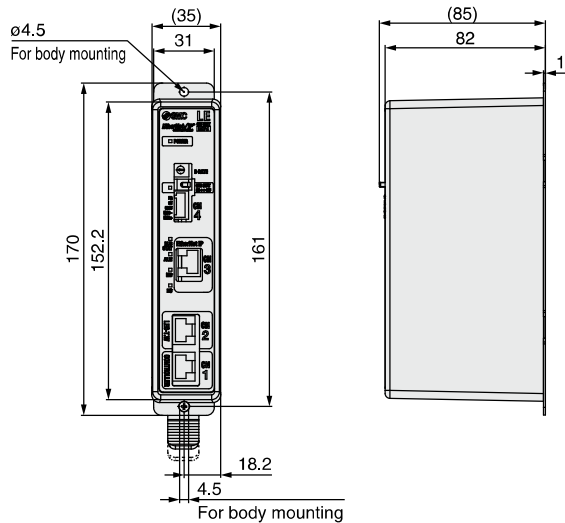

■ Trademark DeviceNet™ is a trademark of ODVA. EtherNet/IP™ is a trademark of ODVA.

# LEC-G Series

## Dimensions

### DIN rail mounting (LEC-G□□□D)

Applicable Fieldbus protocol: CC-Link Ver. 2.0

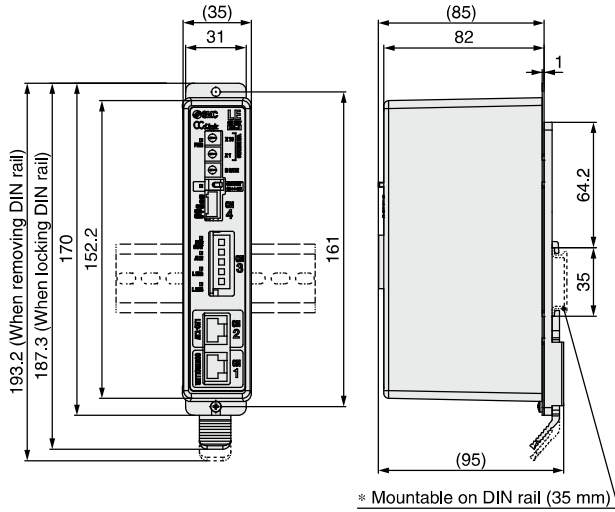

Applicable Fieldbus protocol: DeviceNet™

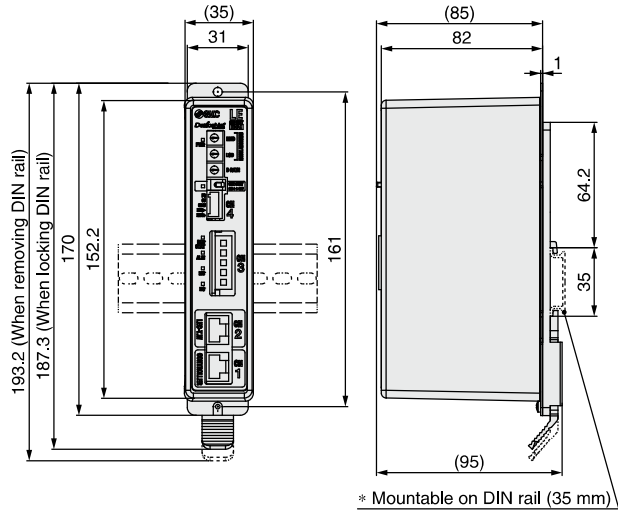

Applicable Fieldbus protocol: PROFIBUS DP

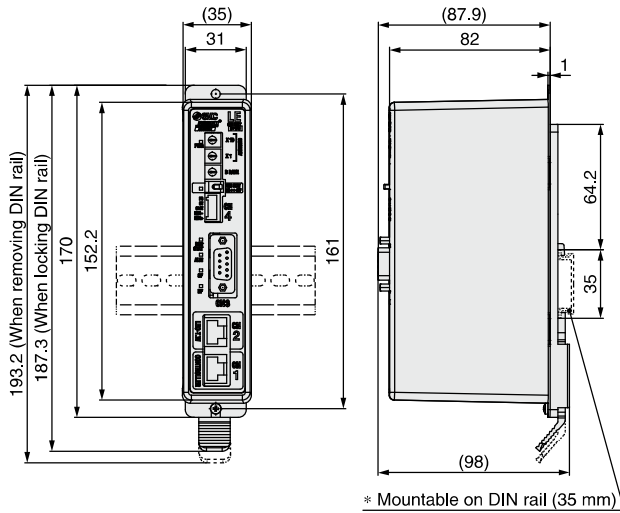

Applicable Fieldbus protocol: EtherNet/IP™

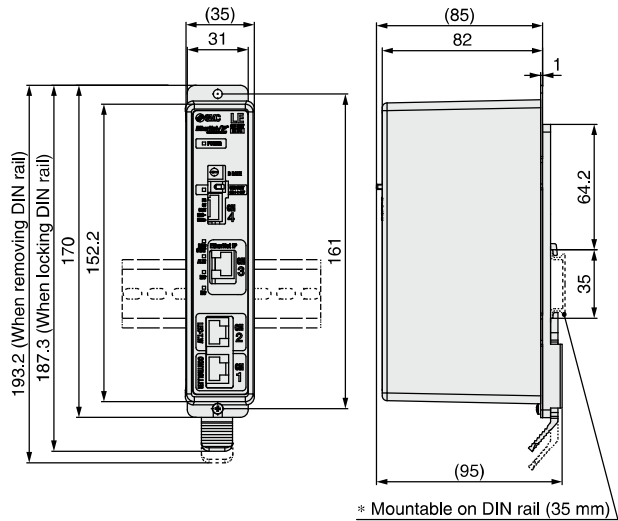

### DIN rail

#### AXT100-DR-□

\* For □, enter a number from the "No." line in the table below. Refer to the dimensions above for the mounting dimensions.

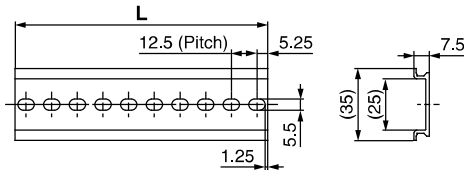

#### L Dimension [mm]

No.	1	2	3	4	5	6	7	8	9	10	11	12	13	14	15	16	17	18	19	20
L	23	35.5	48	60.5	73	85.5	98	110.5	123	135.5	148	160.5	173	185.5	198	210.5	223	235.5	248	260.5
No.	21	22	23	24	25	26	27	28	29	30	31	32	33	34	35	36	37	38	39	40
L	273	285.5	298	310.5	323	335.5	348	360.5	373	385.5	398	410.5	423	435.5	448	460.5	473	485.5	498	510.5

## Wiring Example

### Power Supply Connector: CN1

\* Power supply plug is an accessory.  
 <Applicable cable size> AWG20 (0.5 mm<sup>2</sup>), cover diameter 2.0 mm or less

### CN1 Power Supply Connector Terminal for LEC-G (PHOENIX CONTACT FK-MC0.5/5-ST-2.5)

Terminal name	Function	Details
EMG +	EMG signal output +	Output terminal of the emergency stop switch of the teaching box
EMG -	EMG signal output -	
24V	Power supply + terminal	Power supply terminal of the Gateway unit (Power to the teaching box is supplied from this terminal)
0V	Power supply - terminal	
FG	FG terminal	Grounding terminal

Power supply plug for LEC-G: LEC-D-1-1

\* Accessory

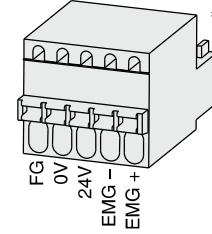

Compatible actuators

LEF LEL LEM  
LEY LES LEP  
LER LEH

# Programless Controller

## LECP1 Series



### How to Order

**LECP1N1** - **LEFS16A-400**

**Controller**

**Compatible motor**

<b>P</b>	Step motor (Servo/24 VDC)
----------	---------------------------

**Number of step data (Points)**

<b>1</b>	14 (Programless)
----------	------------------

**Parallel I/O type**

<b>N</b>	NPN
<b>P</b>	PNP

**Option**

<b>Nil</b>	Screw mounting
<b>D</b> (Note)	DIN rail mounting

Note) DIN rail is not included. Order it separately.

**I/O cable length [m]**

<b>Nil</b>	Without cable
<b>1</b>	1.5
<b>3</b>	3
<b>5</b>	5

**Actuator part number**

(Except cable specifications and actuator options)  
Example: Enter "LEFS16A-400" for the LEFS16A-400B-R11N1.

\* When controller equipped type is selected when ordering the LE series, you do not need to order this controller.

### Caution

#### [CE-compliant products]

EMC compliance was tested by combining the electric actuator LE series and the controller LEC series. The EMC depends on the configuration of the customer's control panel and the relationship with other electrical equipment and wiring. Therefore, conformity to the EMC directive cannot be certified for SMC components incorporated into the customer's equipment under actual operating conditions. As a result, it is necessary for the customer to verify conformity to the EMC directive for the machinery and equipment as a whole.

#### [UL-compliant products]

When conformity to UL is required, the electric actuator and controller should be used with a UL1310 Class 2 power supply.

**The controller is sold as single unit after the compatible actuator is set.**

Confirm that the combination of the controller and the actuator is correct.

\* Refer to the operation manual for using the products. Please download it via our website, <http://www.smcworld.com>

## Specifications

### Basic Specifications

Item	LECP1
<b>Compatible motor</b>	Step motor (Servo/24 VDC)
<b>Power supply</b> (Note 1)	Power supply voltage: 24 VDC $\pm 10\%$ (Note 2) [Including the motor drive power, control power supply, stop, lock release]
<b>Parallel input</b>	6 inputs (Photo-coupler isolation)
<b>Parallel output</b>	6 outputs (Photo-coupler isolation)
<b>Stop points</b>	14 points (Position number 1 to 14(E))
<b>Compatible encoder</b>	Incremental A/B phase (800 pulse/rotation)
<b>Memory</b>	EEPROM
<b>LED indicator</b>	LED (Green/Red) one of each
<b>7-segment LED display</b> (Note 3)	1 digit, 7-segment display (Red) Figures are expressed in hexadecimal ("10" to "15" in decimal number are expressed as "A" to "F")
<b>Lock control</b>	Forced-lock release terminal (Note 4)
<b>Cable length [m]</b>	I/O cable: 5 or less, Actuator cable: 20 or less
<b>Cooling system</b>	Natural air cooling
<b>Operating temperature range [°C]</b>	0 to 40 (No freezing)
<b>Operating humidity range [%RH]</b>	90 or less (No condensation)
<b>Storage temperature range [°C]</b>	-10 to 60 (No freezing)
<b>Storage humidity range [%RH]</b>	90 or less (No condensation)
<b>Insulation resistance [MΩ]</b>	Between the housing and SG terminal: 50 (500 VDC)
<b>Weight [g]</b>	130 (Screw mounting), 150 (DIN rail mounting)

Note 1) Do not use the power supply of "inrush current prevention type" for the controller input power supply. When conformity to UL is required, the electric actuator and controller should be used with a UL1310 Class 2 power supply.

Note 2) The power consumption changes depending on the actuator model. Refer to the each actuator's operation manual etc. for details.

Note 3) "10" to "15" in decimal number are displayed as follows in the 7-segment LED.



Decimal display	10	11	12	13	14	15
Hexadecimal display	A	b	c	d	E	F

Note 4) Applicable to non-magnetizing lock.

## Controller Details

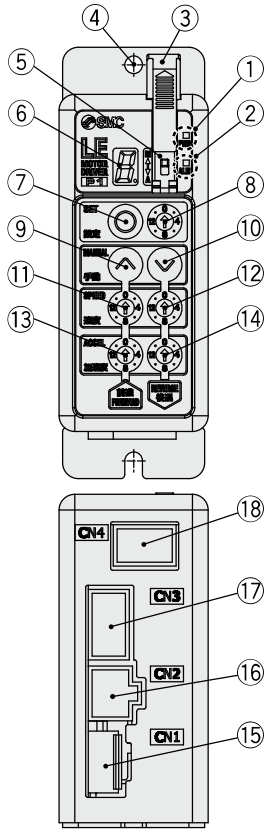

No.	Display	Description	Details
①	<b>PWR</b>	Power supply LED	Power supply ON/Servo ON : Green turns on Power supply ON/Servo OFF: Green flashes
②	<b>ALM</b>	Alarm LED	With alarm : Red turns on Parameter setting : Red flashes
③	—	Cover	Change and protection of the mode switch (Close the cover after changing switch)
④	—	FG	Frame ground (Tighten the screw with the washer when mounting the controller. Connect the ground wire.)
⑤	—	Mode switch	Switch the mode between manual and auto.
⑥	—	7-segment LED	Stop position, the value set by ⑧ and alarm information are displayed.
⑦	<b>SET</b>	Set button	Decide the settings or drive operation in Manual mode.
⑧	—	Position selecting switch	Assign the position to drive (1 to 14), and the origin position (15).
⑨	<b>MANUAL</b>	Manual forward button	Perform forward jog and inching.
⑩		Manual reverse button	Perform reverse jog and inching.
⑪	<b>SPEED</b>	Forward speed switch	16 forward speeds are available.
⑫		Reverse speed switch	16 reverse speeds are available.
⑬	<b>ACCEL</b>	Forward acceleration switch	16 forward acceleration steps are available.
⑭		Reverse acceleration switch	16 reverse acceleration steps are available.
⑮	<b>CN1</b>	Power supply connector	Connect the power supply cable.
⑯	<b>CN2</b>	Motor connector	Connect the motor connector.
⑰	<b>CN3</b>	Encoder connector	Connect the encoder connector.
⑱	<b>CN4</b>	I/O connector	Connect I/O cable.

## How to Mount

Controller mounting shown below.

### 1. Mounting screw (LECP1□□-□)

(Installation with two M4 screws)

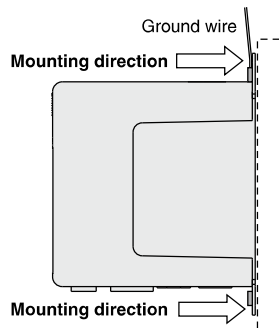

### 2. Grounding

Tighten the screw with the washer when mounting the ground wire as shown below.

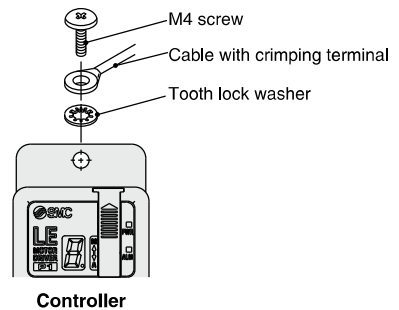

Note) When size 25 or more of the LE series are used, the space between the controllers should be 10 mm or more.

### ⚠ Caution

- M4 screws, cable with crimping terminal and tooth lock washer are not included. Be sure to carry out grounding earth in order to ensure the noise tolerance.
- Use a watchmaker's screwdriver of the size shown below when changing position switch ⑧ and the set value of the speed/acceleration switch ⑪ to ⑭.

#### Size

End width L: 2.0 to 2.4 [mm]  
End thickness W: 0.5 to 0.6 [mm]

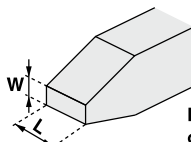

Magnified view of the end of the screwdriver

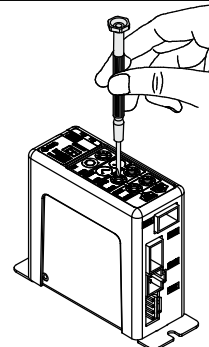

# LECP1 Series

## Dimensions

### Screw mounting (LEC□1□□-□)

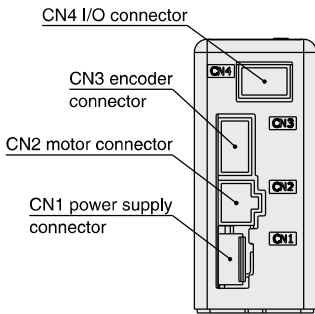
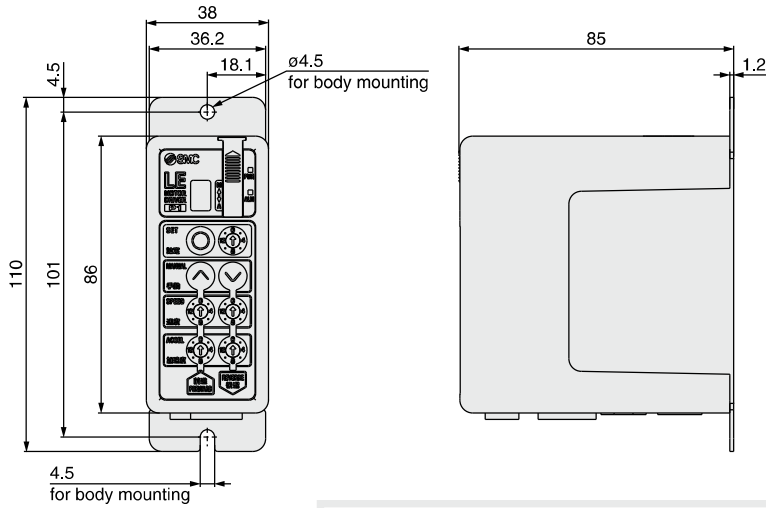

### DIN rail mounting (LEC□1□□D-□)

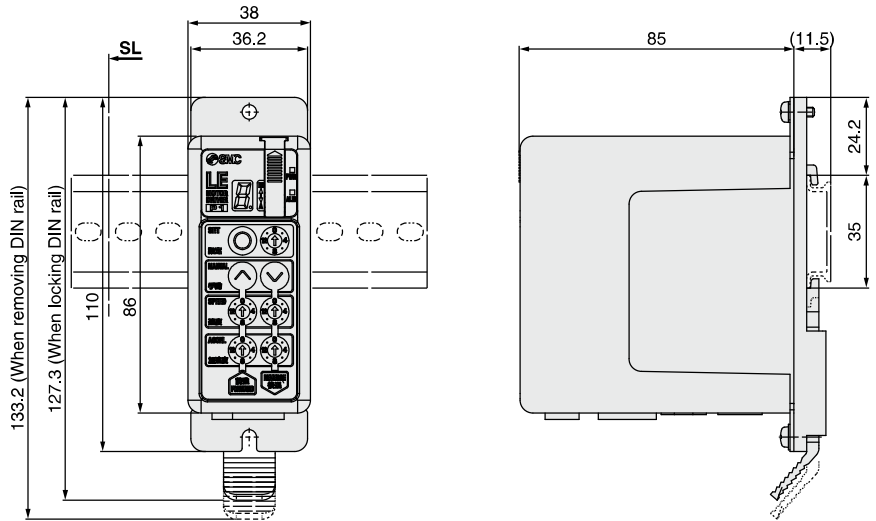

### DIN rail AXT100-DR-□

\* For □, enter a number from the "No." line in the table below.  
Refer to the dimensions above for the mounting dimensions.

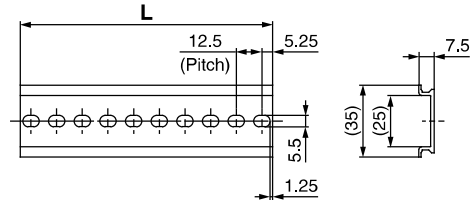

#### L Dimension [mm]

No.	1	2	3	4	5	6	7	8	9	10	11	12	13	14
L	23	35.5	48	60.5	73	85.5	98	110.5	123	135.5	148	160.5	173	185.5
No.	15	16	17	18	19	20	21	22	23	24	25	26	27	28
L	198	210.5	223	235.5	248	260.5	273	285.5	298	310.5	323	335.5	348	360.5
No.	29	30	31	32	33	34	35	36	37	38	39	40		
L	373	385.5	398	410.5	423	435.5	448	460.5	473	485.5	498	510.5		

### DIN rail mounting adapter LEC-1-D0 (with 2 mounting screws)

This should be used when the DIN rail mounting adapter is mounted onto the screw mounting type controller afterwards.

## Wiring Example 1

### Power Supply Connector: CN1

- \* When you connect a CN1 power supply connector, please use the power supply cable (LEC-CK1-1).
- \* Power supply cable (LEC-CK1-1) is an accessory.

### CN1 Power Supply Connector Terminal for LECP1

Terminal name	Cable color	Function	Details
0V	Blue	Common supply (-)	M 24V terminal/C 24V terminal/BK RLS terminal are common (-).
M 24V	White	Motor power supply (+)	Motor power supply (+) supplied to the controller
C 24V	Brown	Control power supply (+)	Control power supply (+) supplied to the controller
BK RLS	Black	Lock release (+)	Input (+) for releasing the lock

### Power supply cable for LECP1 (LEC-CK1-1)

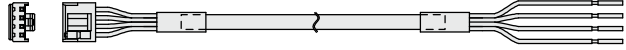

## Wiring Example 2

### Parallel I/O Connector: CN4

- \* When you connect a PLC, etc., to the CN4 parallel I/O connector, please use the I/O cable (LEC-CK4-□).
- \* The wiring should be changed depending on the type of the parallel I/O (NPN or PNP).

#### ■NPN

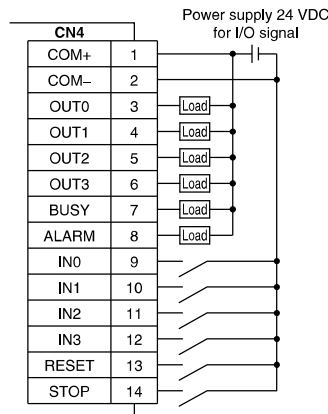

#### ■PNP

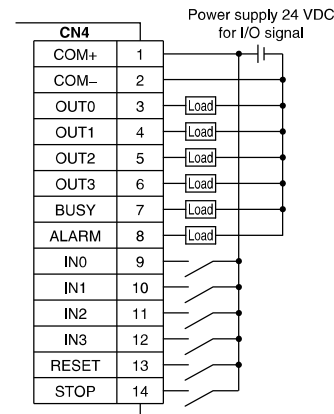

### Input Signal

Name	Details								
COM+	Connects the power supply 24 V for input/output signal								
COM-	Connects the power supply 0 V for input/output signal								
IN0 to IN3	<ul style="list-style-type: none"> <li>• Instruction to drive (input as a combination of IN0 to IN3)</li> <li>• Instruction to return to origin (IN0 to IN3 all ON simultaneously)</li> </ul> <p>Example - (instruction to drive for position no. 5)</p> <table border="1"> <thead> <tr> <th>IN3</th> <th>IN2</th> <th>IN1</th> <th>IN0</th> </tr> </thead> <tbody> <tr> <td>OFF</td> <td>ON</td> <td>OFF</td> <td>ON</td> </tr> </tbody> </table>	IN3	IN2	IN1	IN0	OFF	ON	OFF	ON
IN3	IN2	IN1	IN0						
OFF	ON	OFF	ON						
RESET	Alarm reset and operation interruption During operation: deceleration stop from position at which signal is input (servo ON maintained) While alarm is active: alarm reset								
STOP	Instruction to stop (after maximum deceleration stop, servo OFF)								

### Output Signal

Name	Details
OUT0 to OUT3	Turns on when the positioning or pushing is completed. (Output is instructed in the combination of OUT0 to 3.) Example - (operation complete for position no. 3)
BUSY	Outputs when the actuator is moving
*ALARM (Note)	Not output when alarm is active or servo OFF

Note) Signal of negative-logic circuit (N.C.)

### Input Signal [IN0 - IN3] Position Number Chart ○: OFF ●: ON

Position number	IN3	IN2	IN1	IN0
1	○	○	○	●
2	○	○	○	○
3	○	○	●	●
4	○	●	○	○
5	○	●	○	●
6	○	●	●	○
7	○	○	●	●
8	○	○	○	○
9	●	○	○	●
10 (A)	●	○	●	○
11 (B)	●	○	●	●
12 (C)	●	●	○	○
13 (D)	●	●	○	●
14 (E)	○	○	○	○
Return to origin	●	●	●	●

### Output Signal [OUT0 - OUT3] Position Number Chart ○: OFF ●: ON

Position number	OUT3	OUT2	OUT1	OUT0
1	○	○	○	●
2	○	○	○	○
3	○	○	●	●
4	○	●	○	○
5	○	●	○	●
6	○	●	●	○
7	○	●	●	●
8	●	○	○	○
9	●	○	○	●
10 (A)	●	○	●	○
11 (B)	●	○	●	●
12 (C)	●	●	○	○
13 (D)	●	●	○	●
14 (E)	○	○	○	○
Return to origin	●	●	●	●

# LECP1 Series

## Signal Timing

### (1) Return to Origin

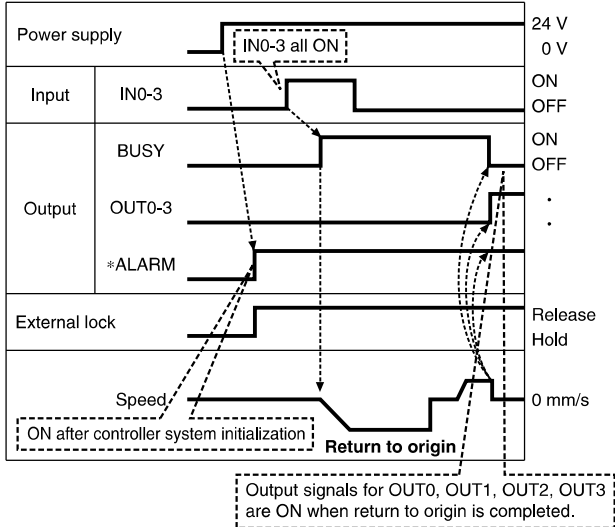

\* \*ALARM" is expressed as negative-logic circuit.

### (2) Positioning Operation

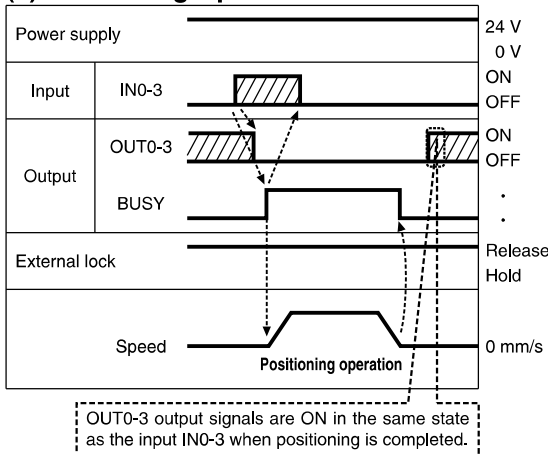

### (4) Stop by the STOP Signal

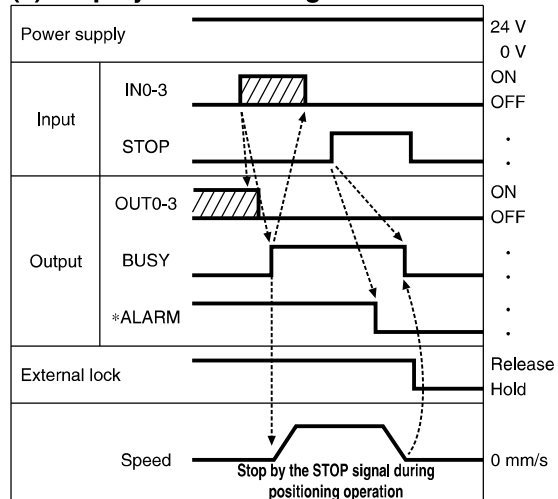

### (3) Cut-off Stop (Reset Stop)

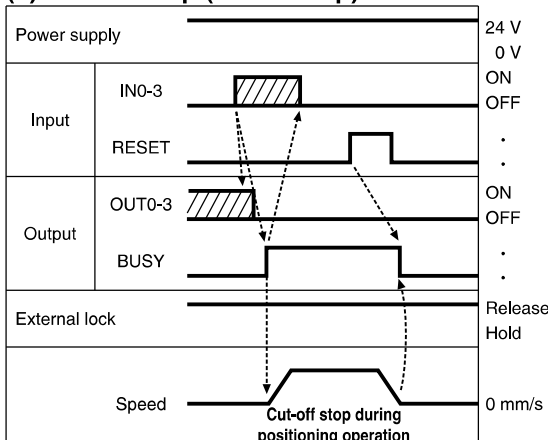

### (5) Alarm Reset

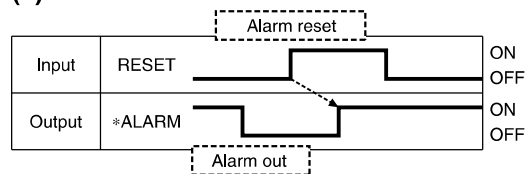

\* \*ALARM" is expressed as negative-logic circuit.

## Options: Actuator Cable

[Robotic cable, standard cable for step motor (Servo/24 VDC)]

**LE-CP-1** - [ ]

Cable length (L) [m]

1	1.5
3	3
5	5
8	8*
A	10*
B	15*
C	20*

\* Produced upon receipt of order (Robotic cable only)

Cable type

Nil	Robotic cable (Flexible cable)
S	Standard cable

### Weight

Product no.	Weight [g]	Note
LE-CP-1-S	190	Standard cable
LE-CP-3-S	280	
LE-CP-5-S	460	
LE-CP-1	140	Robotic cable
LE-CP-3	260	
LE-CP-5	420	
LE-CP-8	790	
LE-CP-A	980	
LE-CP-B	1460	
LE-CP-C	1940	

**LE-CP- $\frac{1}{5}$** /Cable length: 1.5 m, 3 m, 5 m

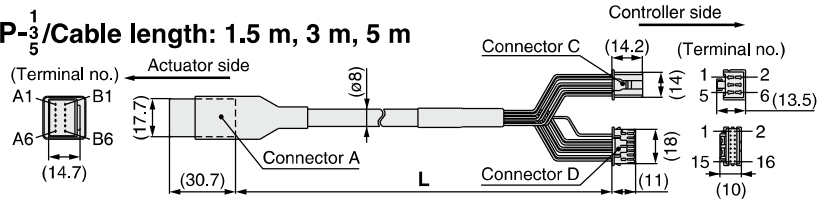

**LE-CP- $\frac{8}{AC}$** /Cable length: 8 m, 10 m, 15 m, 20 m  
(\* Produced upon receipt of order)

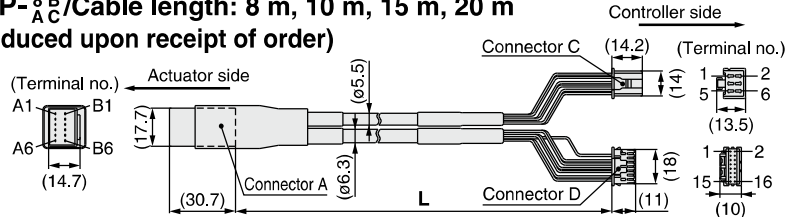

Signal	Connector A terminal no.	Cable color	Connector C terminal no.
A	B-1	Brown	2
A	A-1	Red	1
B	B-2	Orange	6
B	A-2	Yellow	5
COM-A/COM	B-3	Green	3
COM-B/-	A-3	Blue	4
Shield			
Vcc	B-4	Brown	12
GND	A-4	Black	13
A	B-5	Red	7
A	A-5	Black	6
B	B-6	Orange	9
B	A-6	Black	8
		-	3

[Robotic cable, standard cable with lock and sensor for step motor (Servo/24 VDC)]

**LE-CP-1-B** - [ ]

Cable length (L) [m]

1	1.5
3	3
5	5
8	8*
A	10*
B	15*
C	20*

\* Produced upon receipt of order (Robotic cable only)

With lock and sensor

Cable type

Nil	Robotic cable (Flexible cable)
S	Standard cable

### Weight

Product no.	Weight [g]	Note
LE-CP-1-B-S	240	Standard cable
LE-CP-3-B-S	380	
LE-CP-5-B-S	630	
LE-CP-1-B	190	Robotic cable
LE-CP-3-B	360	
LE-CP-5-B	590	
LE-CP-8-B	1060	
LE-CP-A-B	1320	
LE-CP-B-B	1920	
LE-CP-C-B	2620	

**LE-CP- $\frac{1}{5}$** /Cable length: 1.5 m, 3 m, 5 m

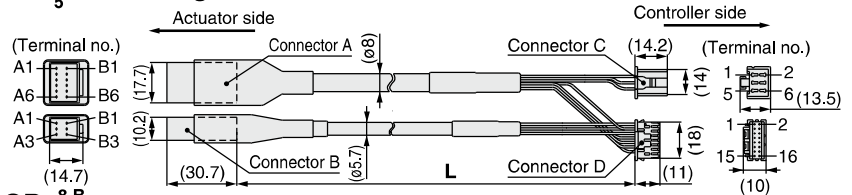

**LE-CP- $\frac{8}{AC}$** /Cable length: 8 m, 10 m, 15 m, 20 m  
(\* Produced upon receipt of order)

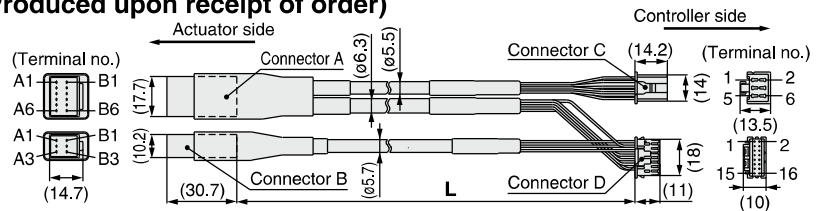

Signal	Connector A terminal no.	Cable color	Connector C terminal no.
A	B-1	Brown	2
A	A-1	Red	1
B	B-2	Orange	6
B	A-2	Yellow	5
COM-A/COM	B-3	Green	3
COM-B/-	A-3	Blue	4
Shield			
Vcc	B-4	Brown	12
GND	A-4	Black	13
A	B-5	Red	7
A	A-5	Black	6
B	B-6	Orange	9
B	A-6	Black	8
		-	3

Signal	Connector B terminal no.	Cable color	Connector D terminal no.
Lock (+)	B-1	Red	4
Lock (-)	A-1	Black	5
Sensor (+)	B-3	Brown	1
Sensor (-)	A-3	Blue	2

# LECP1 Series

## Options

### [Power supply cable]

#### LEC-CK1-1

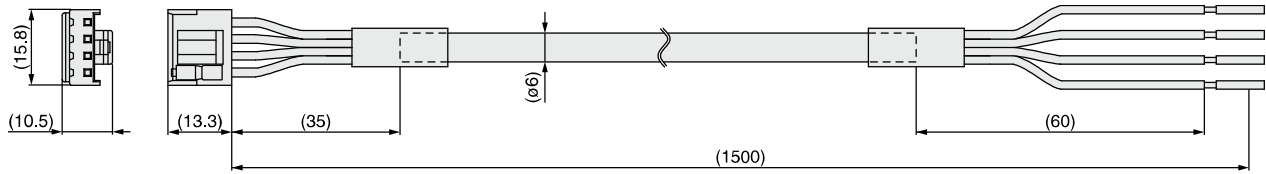

Terminal name	Covered color	Function
0V	Blue	Common supply (-)
M 24V	White	Motor power supply (+)
C 24V	Brown	Control power supply (+)
BK RLS	Black	Lock release (+)

\* Conductor size: AWG20

Weight: 90 g

### [I/O cable]

#### LEC-CK4-□

Cable length (L) [m]

1	1.5
3	3
5	5

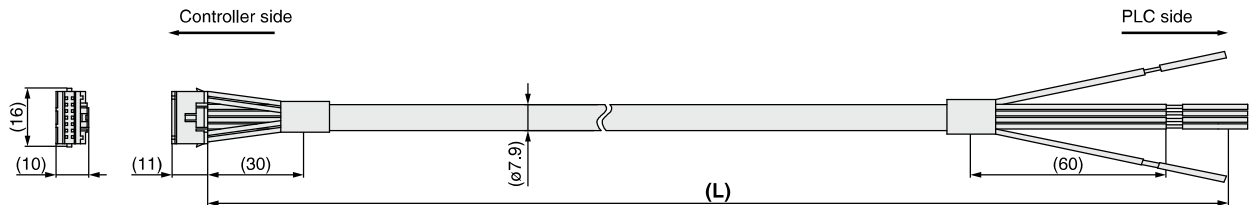

Terminal no.	Insulation color	Dot mark	Dot color	Function
1	Light brown	■	Black	COM+
2	Light brown	■	Red	COM-
3	Yellow	■	Black	OUT0
4	Yellow	■	Red	OUT1
5	Light green	■	Black	OUT2
6	Light green	■	Red	OUT3
7	Gray	■	Black	BUSY
8	Gray	■	Red	ALARM
9	White	■	Black	IN0
10	White	■	Red	IN1
11	Light brown	■ ■	Black	IN2
12	Light brown	■ ■	Red	IN3
13	Yellow	■ ■	Black	RESET
14	Yellow	■ ■	Red	STOP

\* Conductor size: AWG26

#### Weight

Product no.	Weight [g]
LEC-CK4-1	100
LEC-CK4-3	200
LEC-CK4-5	330

\* Parallel I/O signal is valid in auto mode. While the test function operates at manual mode, only the output is valid.

Compatible actuator

LEM

Specialized for LEM series

# Programless Controller (With Stroke Study)

## LECP2 Series



### How to Order

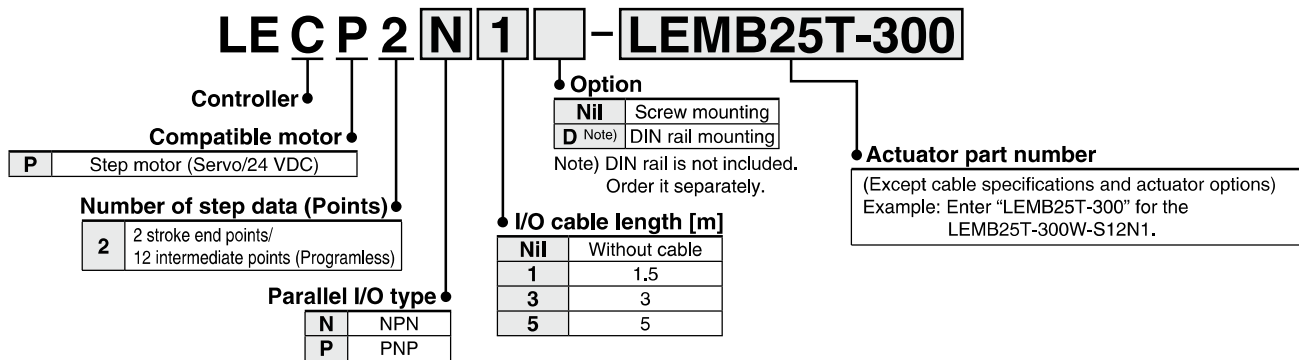

#### Caution

##### [CE-compliant products]

EMC compliance was tested by combining the electric actuator LEM series and the controller LEC series. The EMC depends on the configuration of the customer's control panel and the relationship with other electrical equipment and wiring. Therefore, conformity to the EMC directive cannot be certified for SMC components incorporated into the customer's equipment under actual operating conditions. As a result, it is necessary for the customer to verify conformity to the EMC directive for the machinery and equipment as a whole.

##### [UL-compliant products]

When conformity to UL is required, the electric actuator and controller should be used with a UL1310 Class 2 power supply.

#### The controller is sold as single unit after the compatible actuator is set.

Confirm that the combination of the controller and the actuator is correct.

\* Refer to the operation manual for using the products. Please download it via our website, <http://www.smcworld.com>

## Specifications

### Basic Specifications

Item	LECP2
Compatible motor	Step motor (Servo/24 VDC)
Power supply <sup>Note 1)</sup>	Power supply voltage: 24 VDC $\pm 10\%$ <sup>Note 2)</sup> [Including the motor drive power, control power supply, stop, lock release]
Parallel input	6 inputs (Photo-coupler isolation)
Parallel output	6 outputs (Photo-coupler isolation)
Stop points	Stroke ends 2 points (Position number 1 and 2), Intermediate position 12 points (Position number 3 to 14(E))
Compatible encoder	Incremental A/B phase (800 pulse/rotation)
Memory	EEPROM
LED indicator	LED (Green/Red) one of each
7-segment LED display <sup>Note 3)</sup>	1 digit, 7-segment display (Red) Figures are expressed in hexadecimal. ("10" to "15" in decimal number are expressed as "A" to "F")
Lock control	Forced-lock release terminal <sup>Note 4)</sup>
Cable length [m]	I/O cable: 5 or less, Actuator cable: 20 or less
Cooling system	Natural air cooling
Operating temperature range [°C]	0 to 40 (No freezing)
Operating humidity range [%RH]	90 or less (No condensation)
Storage temperature range [°C]	-10 to 60 (No freezing)
Storage humidity range [%RH]	90 or less (No condensation)
Insulation resistance [M $\Omega$ ]	Between the housing and SG terminal: 50 (500 VDC)
Weight [g]	130 (Screw mounting), 150 (DIN rail mounting)

Note 1) Do not use the power supply of "inrush current prevention type" for the controller input power supply. When conformity to UL is required, the electric actuator and controller should be used with a UL1310 Class 2 power supply.

Note 2) The power consumption changes depending on the actuator model. Refer to the each actuator's operation manual etc. for details.

Note 3) "10" to "15" in decimal number are displayed as follows in the 7-segment LED.



Decimal display: 10, 11, 12, 13, 14, 15  
Hexadecimal display: A, b, c, d, E, F

Note 4) Applicable to non-magnetizing lock

# LECP2 Series

## Controller Details

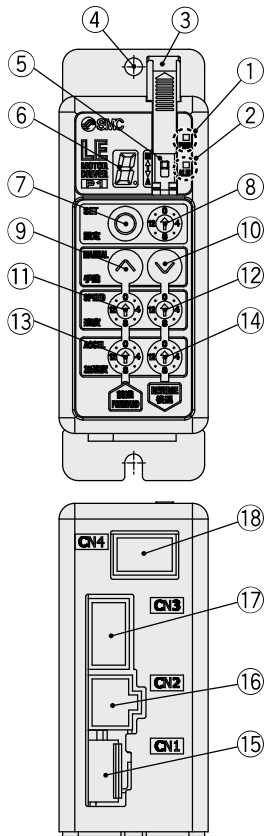

No.	Display	Description	Details
①	<b>PWR</b>	Power supply LED	Power supply ON/Servo ON : Green turns on. Power supply ON/Servo OFF: Green flashes.
②	<b>ALM</b>	Alarm LED	With alarm : Red turns on. Parameter setting : Red flashes.
③	—	Cover	Change and protection of the mode switch (Close the cover after changing switch.)
④	—	FG	Frame ground (Tighten the screw with the washer when mounting the controller. Connect the ground wire.)
⑤	—	Mode switch	Switch the mode between manual and auto.
⑥	—	7-segment LED	Stop position, the value set by ⑧ and alarm information are displayed.
⑦	<b>SET</b>	Set button	Decide the settings or drive operation in manual mode.
⑧	—	Position selecting switch	Assign the position to drive (1 to 14), and the origin position (15).
⑨	<b>MANUAL</b>	Manual forward button	Perform forward jog and inching.
⑩		Manual reverse button	Perform reverse jog and inching.
⑪	<b>SPEED</b>	Forward speed switch	16 forward speeds are available.
⑫		Reverse speed switch	16 reverse speeds are available.
⑬	<b>ACCEL</b>	Forward acceleration switch	16 forward acceleration steps are available.
⑭		Reverse acceleration switch	16 reverse acceleration steps are available.
⑮	<b>CN1</b>	Power supply connector	Connect the power supply cable.
⑯	<b>CN2</b>	Motor connector	Connect the motor connector.
⑰	<b>CN3</b>	Encoder connector	Connect the encoder connector.
⑱	<b>CN4</b>	I/O connector	Connect the I/O cable.

## How to Mount

Controller mounting shown below

### 1. Screw mounting (LECP2□□-□)

(Installation with two M4 screws)

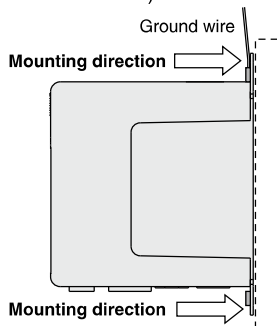

### 2. Grounding

Tighten the screw with the washer when mounting the ground wire as shown below.

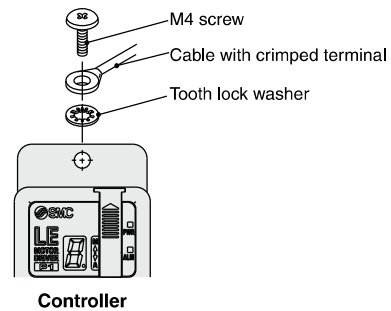

Note) The space between the controllers should be 10 mm or more.

### ⚠ Caution

- M4 screws, cable with crimping terminal and tooth lock washer are not included. Be sure to carry out grounding earth in order to ensure the noise tolerance.
- Use a watchmaker's screwdriver of the size shown below when changing position switch ⑧ and the set value of the speed/acceleration switch ⑪ to ⑭.

#### Size

End width L: 2.0 to 2.4 [mm]  
End thickness W: 0.5 to 0.6 [mm]

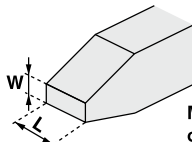

Magnified view of the end of the screwdriver

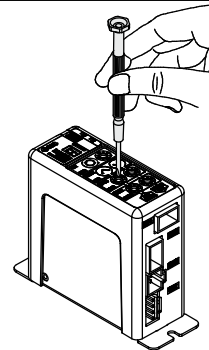

## Dimensions

### Screw mounting (LEC□2□□-□)

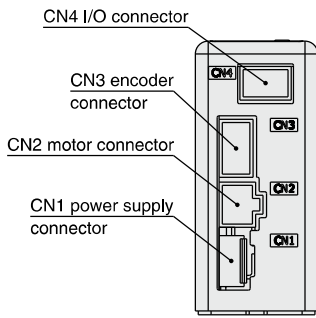
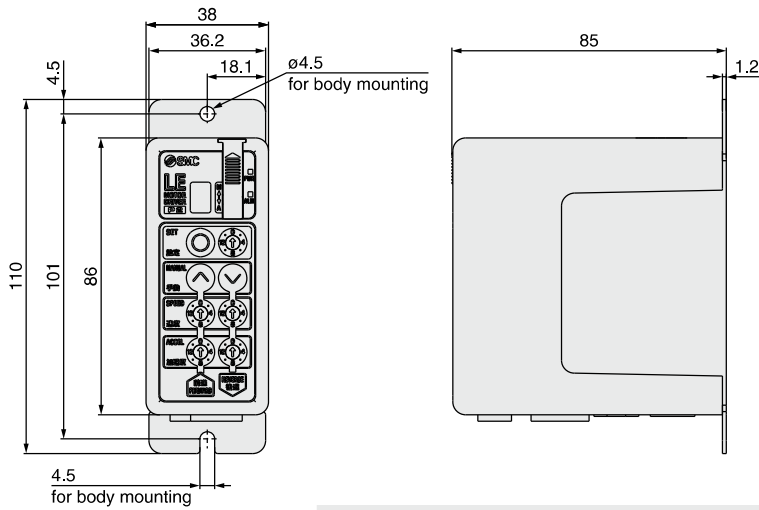

### DIN rail mounting (LEC□2□□D-□)

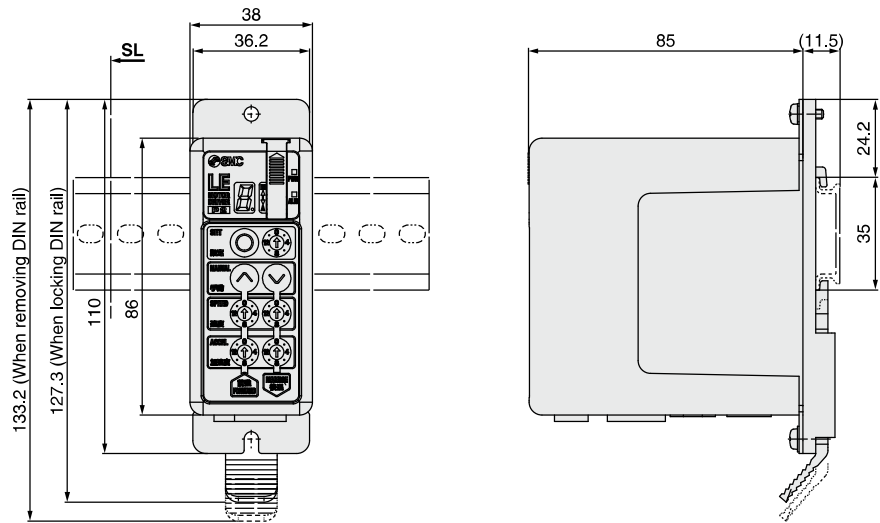

### DIN rail AXT100-DR-□

\* For □, enter a number from the "No." line in the table below.  
Refer to the dimensions above for the mounting dimensions.

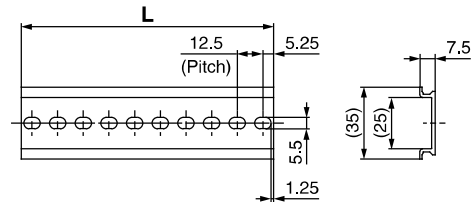

#### L Dimension [mm]

No.	1	2	3	4	5	6	7	8	9	10	11	12	13	14
L	23	35.5	48	60.5	73	85.5	98	110.5	123	135.5	148	160.5	173	185.5
No.	15	16	17	18	19	20	21	22	23	24	25	26	27	28
L	198	210.5	223	235.5	248	260.5	273	285.5	298	310.5	323	335.5	348	360.5
No.	28	29	30	31	32	33	34	35	36	37	38	39	40	
L	360.5	373	385.5	398	410.5	423	435.5	448	460.5	473	485.5	498	510.5	

### DIN rail mounting adapter LEC-1-D0 (with 2 mounting screws)

This should be used when the DIN rail mounting adapter is mounted onto the screw mounting type controller afterwards.

# LECP2 Series

## Wiring Example 1

### Power Supply Connector: CN1

- \* When you connect a CN1 power supply connector, use the power supply cable (LEC-CK1-1).
- \* Power supply cable (LEC-CK1-1) is an accessory.

### CN1 Power Supply Connector Terminal for LECP2

Terminal name	Cable color	Function	Details
0V	Blue	Common supply (-)	M 24V terminal/C 24V terminal/BK RLS terminal are common (-).
M 24V	White	Motor power supply (+)	Motor power supply (+) supplied to the controller
C 24V	Brown	Control power supply (+)	Control power supply (+) supplied to the controller
BK RLS	Black	Lock release (+)	Input (+) for releasing the lock

### Power supply cable for LECP2 (LEC-CK1-1)

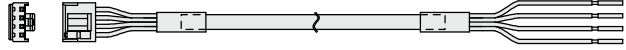

## Wiring Example 2

### Parallel I/O Connector: CN4

- \* When you connect a PLC, etc., to the CN4 parallel I/O connector, use the I/O cable (LEC-CK4-□).
- \* The wiring should be changed depending on the type of the parallel I/O (NPN or PNP).

#### ■ NPN

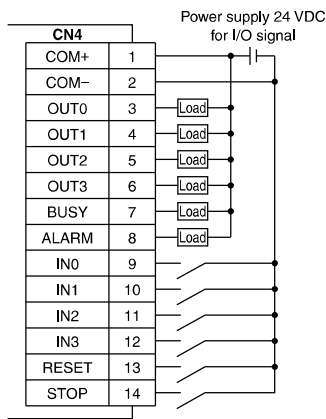

#### ■ PNP

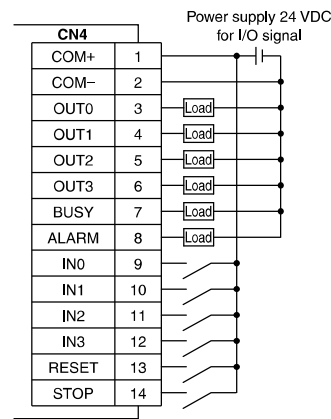

### Input Signal

Name	Details								
COM+	Connects the power supply 24 V for input/output signal								
COM-	Connects the power supply 0 V for input/output signal								
IN0 to IN3	<ul style="list-style-type: none"> <li>• Instruction to drive (input as a combination of IN0 to IN3) Example - (instruction to drive for position no. 5)</li> </ul> <table border="1"> <thead> <tr> <th>IN3</th> <th>IN2</th> <th>IN1</th> <th>IN0</th> </tr> </thead> <tbody> <tr> <td>OFF</td> <td>ON</td> <td>OFF</td> <td>ON</td> </tr> </tbody> </table> <ul style="list-style-type: none"> <li>• Instruction to return to origin (After the power is turned ON, first turn on IN0 or IN1. Return to origin using IN0: Return to origin by moving to the extended end. Return to origin using IN1: Return to origin by moving to the motor end.)</li> </ul>	IN3	IN2	IN1	IN0	OFF	ON	OFF	ON
IN3	IN2	IN1	IN0						
OFF	ON	OFF	ON						
RESET	Alarm reset and operation interruption During operation: deceleration stop from position at which signal is input (servo ON maintained) While alarm is active: alarm reset								
STOP	Instruction to stop (after maximum deceleration stop, servo OFF)								

### Output Signal

Name	Details								
OUT0 to OUT3	<ul style="list-style-type: none"> <li>• Positioning completion (input as a combination of OUT0 to OUT3) Example - (positioning completion for position no. 3)</li> </ul> <table border="1"> <thead> <tr> <th>OUT3</th> <th>OUT2</th> <th>OUT1</th> <th>OUT0</th> </tr> </thead> <tbody> <tr> <td>OFF</td> <td>OFF</td> <td>ON</td> <td>ON</td> </tr> </tbody> </table> <ul style="list-style-type: none"> <li>• Return to origin completion (Completion of return to origin using IN0: Only OUT0 is ON.) (Completion of return to origin using IN1: Only OUT1 is ON.)</li> </ul>	OUT3	OUT2	OUT1	OUT0	OFF	OFF	ON	ON
OUT3	OUT2	OUT1	OUT0						
OFF	OFF	ON	ON						
BUSY	Outputs when the actuator is moving								
*ALARM (Note)	Not output when alarm is active or servo OFF								

Note) Signal of negative-logic circuit (N.C.)

### Input Signal [IN0 - IN3] Position Number Chart ○: OFF ●: ON

Position number	IN3	IN2	IN1	IN0
1 (End side)	○	○	○	●
2 (Motor side)	○	○	●	○
3	○	○	●	●
4	○	●	○	○
5	○	●	○	●
6	○	●	●	○
7	○	●	●	○
8	●	○	○	○
9	●	○	○	●
10 (A)	●	○	●	○
11 (B)	●	○	●	●
12 (C)	●	●	○	○
13 (D)	●	●	○	●
14 (E)	●	●	●	○

### Output Signal [OUT0 - OUT3] Position Number Chart ○: OFF ●: ON

Position number	OUT3	OUT2	OUT1	OUT0
1 (End side)	○	○	○	●
2 (Motor side)	○	○	●	○
3	○	○	●	●
4	○	●	○	○
5	○	●	○	●
6	○	●	●	○
7	○	●	●	○
8	●	○	○	○
9	●	○	○	●
10 (A)	●	○	●	○
11 (B)	●	○	●	●
12 (C)	●	●	○	○
13 (D)	●	●	○	●
14 (E)	●	●	●	○

## Signal Timing

### (1) Positioning Operation [Driving to the stroke end]

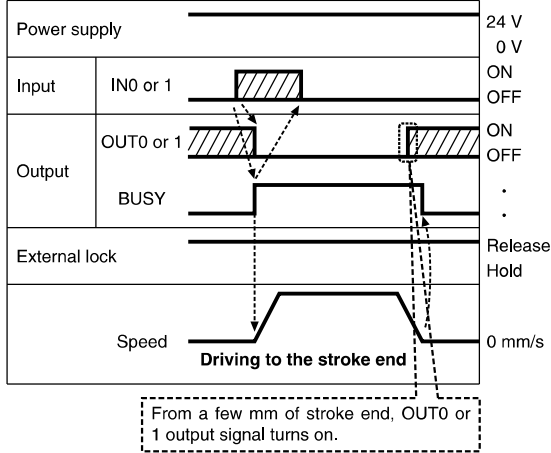

### (2) Positioning Operation [Driving to the intermediate position]

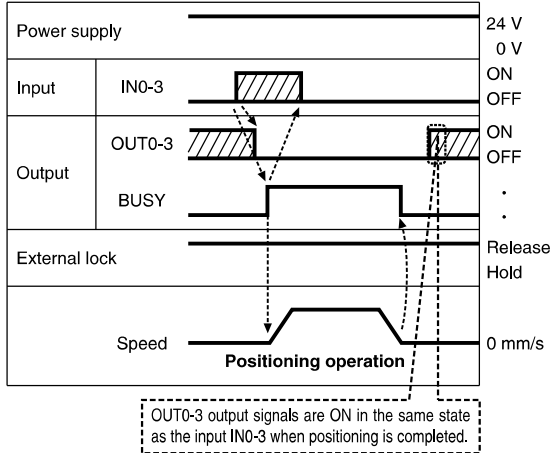

### (3) Cut-off Stop (Reset Stop)

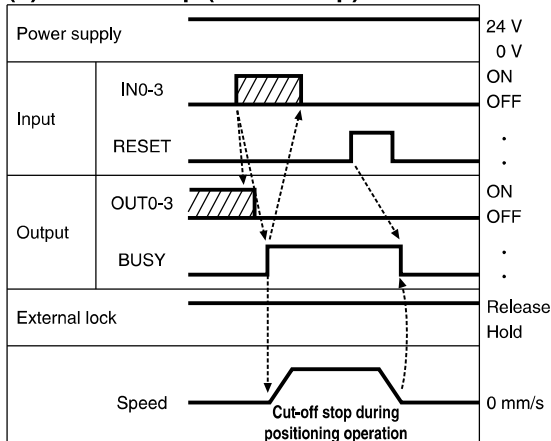

### (4) Stop by the STOP Signal

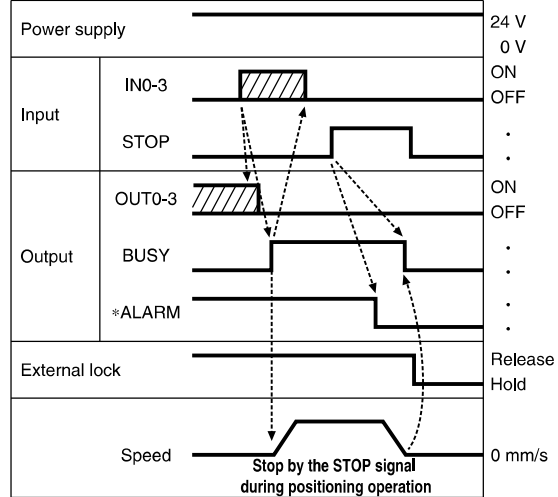

### (5) Alarm Reset

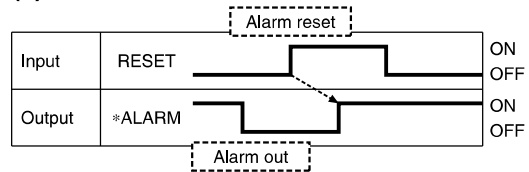

\*ALARM is expressed as negative-logic circuit.

# LECP2 Series

## Options: Actuator Cable

[Robotic cable, standard cable for step motor (Servo/24 VDC)]

LE-CP-1-□

Cable length (L) [m]

1	1.5
3	3
5	5
8	8*
A	10*
B	15*
C	20*

\* Produced upon receipt of order (Robotic cable only)

Cable type

Nil	Robotic cable (Flexible cable)
S	Standard cable

### Weight

Product no.	Weight [g]	Note
LE-CP-1-S	190	Standard cable
LE-CP-3-S	280	
LE-CP-5-S	460	
LE-CP-1	140	Robotic cable
LE-CP-3	260	
LE-CP-5	420	
LE-CP-8	790	
LE-CP-A	980	
LE-CP-B	1460	
LE-CP-C	1940	

LE-CP- $\frac{1}{5}$ /Cable length: 1.5 m, 3 m, 5 m

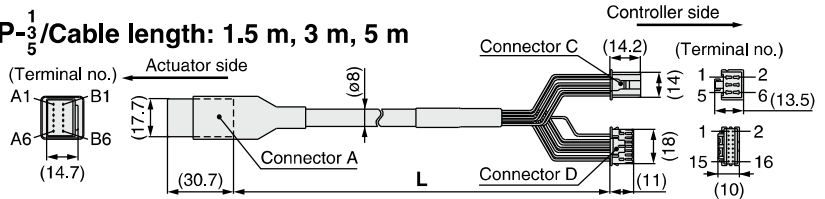

LE-CP- $\frac{8}{AC}$ /Cable length: 8 m, 10 m, 15 m, 20 m  
(\* Produced upon receipt of order)

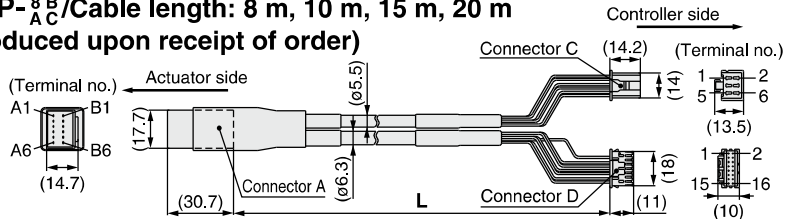

Signal	Connector A terminal no.	Cable color	Connector C terminal no.
A	B-1	Brown	2
A	A-1	Red	1
B	B-2	Orange	6
B	A-2	Yellow	5
COM-A/COM	B-3	Green	3
COM-B/-	A-3	Blue	4
Shield			
Vcc	B-4	Brown	12
GND	A-4	Black	13
A	B-5	Red	7
A	A-5	Black	6
B	B-6	Orange	9
B	A-6	Black	8
		-	3

[Robotic cable, standard cable with lock and sensor for step motor (Servo/24 VDC)]

LE-CP-1-B-□

Cable length (L) [m]

1	1.5
3	3
5	5
8	8*
A	10*
B	15*
C	20*

\* Produced upon receipt of order (Robotic cable only)

With lock and sensor

Cable type

Nil	Robotic cable (Flexible cable)
S	Standard cable

### Weight

Product no.	Weight [g]	Note
LE-CP-1-B-S	240	Standard cable
LE-CP-3-B-S	380	
LE-CP-5-B-S	630	
LE-CP-1-B	190	Robotic cable
LE-CP-3-B	360	
LE-CP-5-B	590	
LE-CP-8-B	1060	
LE-CP-A-B	1320	
LE-CP-B-B	1920	
LE-CP-C-B	2620	

LE-CP- $\frac{1}{5}$ /Cable length: 1.5 m, 3 m, 5 m

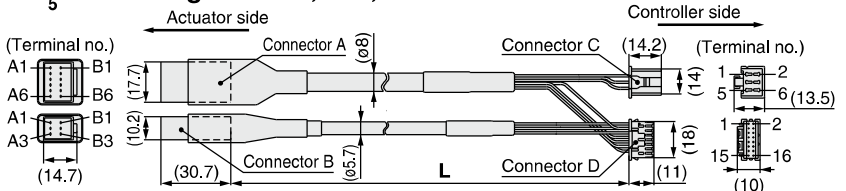

LE-CP- $\frac{8}{AC}$ /Cable length: 8 m, 10 m, 15 m, 20 m  
(\* Produced upon receipt of order)

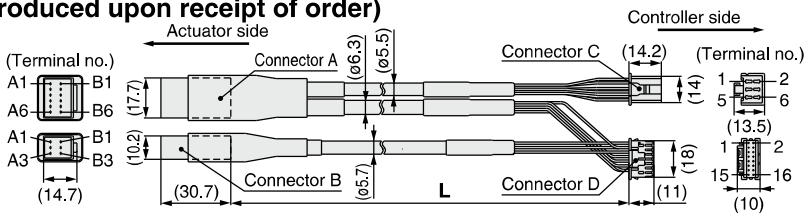

Signal	Connector A terminal no.	Cable color	Connector C terminal no.
A	B-1	Brown	2
A	A-1	Red	1
B	B-2	Orange	6
B	A-2	Yellow	5
COM-A/COM	B-3	Green	3
COM-B/-	A-3	Blue	4
Shield			
Vcc	B-4	Brown	12
GND	A-4	Black	13
A	B-5	Red	7
A	A-5	Black	6
B	B-6	Orange	9
B	A-6	Black	8
		-	3

  

Signal	Connector B terminal no.	Cable color	Connector D terminal no.
Lock (+)	B-1	Red	4
Lock (-)	A-1	Black	5
Sensor (+)	B-3	Brown	1
Sensor (-)	A-3	Blue	2

## Options

### [Power supply cable]

#### LEC-CK1-1

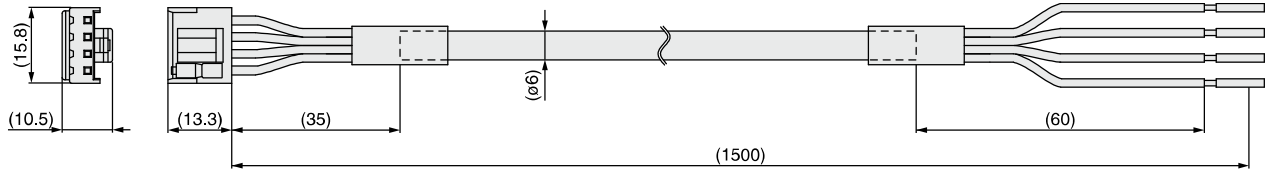

Terminal name	Covered color	Function
0V	Blue	Common supply (-)
M 24V	White	Motor power supply (+)
C 24V	Brown	Control power supply (+)
BK RLS	Black	Lock release (+)

\* Conductor size: AWG20

Weight: 90 g

### [I/O cable]

#### LEC-CK4-□

Cable length (L) [m]

1	1.5
3	3
5	5

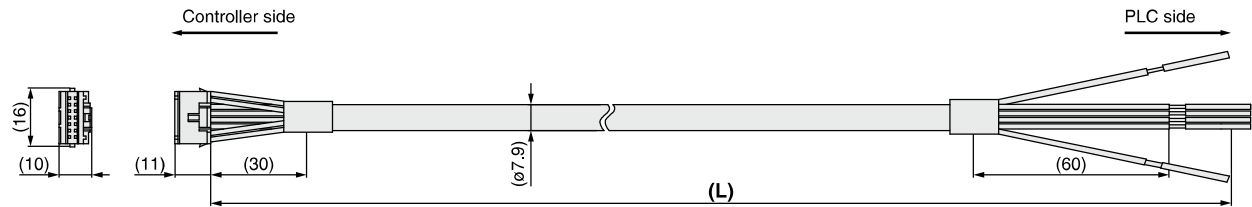

Terminal no.	Insulation color	Dot mark	Dot color	Function
1	Light brown	■	Black	COM+
2	Light brown	■	Red	COM-
3	Yellow	■	Black	OUT0
4	Yellow	■	Red	OUT1
5	Light green	■	Black	OUT2
6	Light green	■	Red	OUT3
7	Gray	■	Black	BUSY
8	Gray	■	Red	ALARM
9	White	■	Black	IN0
10	White	■	Red	IN1
11	Light brown	■ ■	Black	IN2
12	Light brown	■ ■	Red	IN3
13	Yellow	■ ■	Black	RESET
14	Yellow	■ ■	Red	STOP

\* Conductor size: AWG26

#### Weight

Product no.	Weight [g]
<b>LEC-CK4-1</b>	100
<b>LEC-CK4-3</b>	200
<b>LEC-CK4-5</b>	330

\* Parallel I/O signal is valid in auto mode. While the test function operates at manual mode, only the output is valid.

Compatible actuators

LEF LEY LES  
LEP LER LEH

# Step Motor Driver

## LECPA Series



### How to Order

#### ⚠ Caution

##### [CE-compliant products]

① EMC compliance was tested by combining the electric actuator LE series and the LECPA series. The EMC depends on the configuration of the customer's control panel and the relationship with other electrical equipment and wiring. Therefore, conformity to the EMC directive cannot be certified for SMC components incorporated into the customer's equipment under actual operating conditions. As a result, it is necessary for the customer to verify conformity to the EMC directive for the machinery and equipment as a whole.

② For the LECPA series (step motor driver), EMC compliance was tested by installing a noise filter set (LEC-NFA).

Refer to page 568 for the noise filter set. Refer to the LECPA Operation Manual for installation.

##### [UL-compliant products]

When conformity to UL is required, the electric actuator and driver should be used with a UL1310 Class 2 power supply.

LECP AN 1 - LEFS16B-100

#### Driver type

AN	Pulse input type (NPN)
AP	Pulse input type (PNP)

#### I/O cable length [m]

Nil	None
1	1.5
3	3*
5	5*

\* Pulse input usable only with differential. Only 1.5 m cables usable with open collector.

#### Driver mounting

Nil	Screw mounting
D <sup>Note)</sup>	DIN rail mounting

Note) DIN rail is not included. Order it separately.

#### Actuator part number

Part number except cable specifications and actuator options

Example: Enter "LEFS16B-100" for the LEFS16B-100B-R1AN1D.

BC	Blank controller <sup>Note)</sup>
----	-----------------------------------

Note) The dedicated software (LEC-BCW) is required.

\* When controller equipped type is selected when ordering the LE series, you do not need to order this driver.  
\* When pulse signals are open collector, order the current limiting resistor (LEC-PA-R-□) separately.

### The driver is sold as single unit after the compatible actuator is set.

Confirm that the combination of the driver and the actuator is correct.

#### <Check the following before use.>

- Check the actuator label for model number. This matches the driver.
- Check Parallel I/O configuration matches (NPN or PNP).

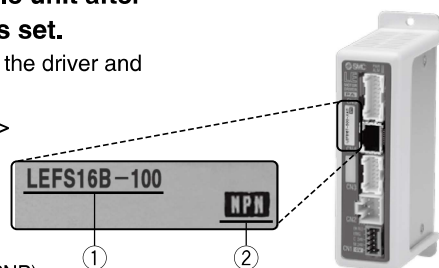

\* Refer to the operation manual for using the products. Please download it via our website, <http://www.smcworld.com>

### Precautions on blank controller (LECPA□□-BC)

Blank controller is a controller to which the customer can write the data of the actuator to be combined and used. Use the dedicated software (LEC-BCW) for data writing.

- Please download the dedicated software (LEC-BCW) via our website.
- Order the communication cable for controller setting (LEC-W2A-C) separately to use this software.

SMC website

<https://www.smcworld.com>

## Specifications

Item	LECPA
<b>Compatible motor</b>	Step motor (Servo/24 VDC)
<b>Power supply</b> <sup>Note 1)</sup>	Power voltage: 24 VDC ±10% <sup>Note 2)</sup> [Including motor drive power, control power, stop, lock release]
<b>Parallel input</b>	5 inputs (Except photo-coupler isolation, pulse input terminal, COM terminal)
<b>Parallel output</b>	9 outputs (Photo-coupler isolation)
<b>Pulse signal input</b>	Maximum frequency: 60 kpps (Open collector), 200 kpps (Differential) Input method: 1 pulse mode (Pulse input in direction), 2 pulse mode (Pulse input in differing directions)
<b>Compatible encoder</b>	Incremental A/B phase (Encoder resolution: 800 pulse/rotation)
<b>Serial communication</b>	RS485 (Modbus protocol compliant)
<b>Memory</b>	EEPROM
<b>LED indicator</b>	LED (Green/Red) one of each
<b>Lock control</b>	Forced-lock release terminal <sup>Note 3)</sup>
<b>Cable length [m]</b>	I/O cable: 1.5 or less (Open collector), 5 or less (Differential), Actuator cable: 20 or less
<b>Cooling system</b>	Natural air cooling
<b>Operating temperature range [°C]</b>	0 to 40 (No freezing)
<b>Operating humidity range [%RH]</b>	90 or less (No condensation)
<b>Storage temperature range [°C]</b>	-10 to 60 (No freezing)
<b>Storage humidity range [%RH]</b>	90 or less (No condensation)
<b>Insulation resistance [MΩ]</b>	Between the housing and SG terminal: 50 (500 VDC)
<b>Weight [g]</b>	120 (Screw mounting), 140 (DIN rail mounting)

Note 1) Do not use the power supply of "inrush current prevention type" for the driver power supply. When conformity to UL is required, the electric actuator and driver should be used with a UL1310 Class 2 power supply.

Note 2) The power consumption changes depending on the actuator model. Refer to the specifications of actuator for more details.

Note 3) Applicable to non-magnetizing lock.

## How to Mount

a) Screw mounting (LECPA□□-□)  
(Installation with two M4 screws)

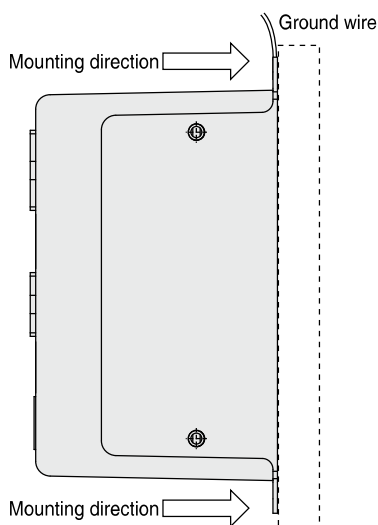

b) DIN rail mounting (LECPA□□D-□)  
(Installation with the DIN rail)

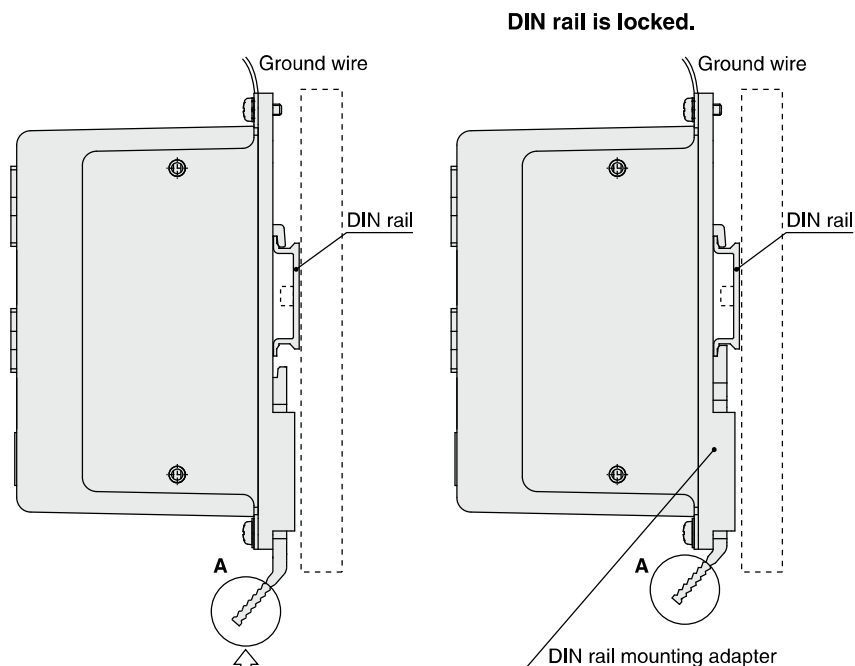

Hook the driver on the DIN rail and press the lever of section **A** in the arrow direction to lock it.

Note) The space between the drivers should be 10 mm or more.

### DIN rail AXT100-DR-□

\* For □, enter a number from the "No." line in the table below.  
Refer to the dimensions on page 592 for the mounting dimensions.

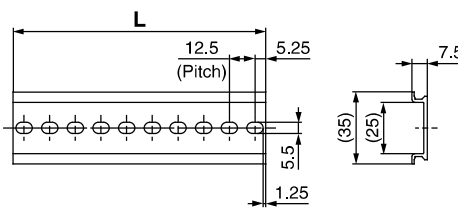

#### L Dimension [mm]

No.	1	2	3	4	5	6	7	8	9	10	11	12	13	14	15	16	17	18	19	20
<b>L</b>	23	35.5	48	60.5	73	85.5	98	110.5	123	135.5	148	160.5	173	185.5	198	210.5	223	235.5	248	260.5
No.	21	22	23	24	25	26	27	28	29	30	31	32	33	34	35	36	37	38	39	40
<b>L</b>	273	285.5	298	310.5	323	335.5	348	360.5	373	385.5	398	410.5	423	435.5	448	460.5	473	485.5	498	510.5

### DIN rail mounting adapter LEC-2-D0 (with 2 mounting screws)

This should be used when the DIN rail mounting adapter is mounted onto the screw mounting type driver afterwards.

# LECPA Series

## Dimensions

### a) Screw mounting (LECPA□□-□)

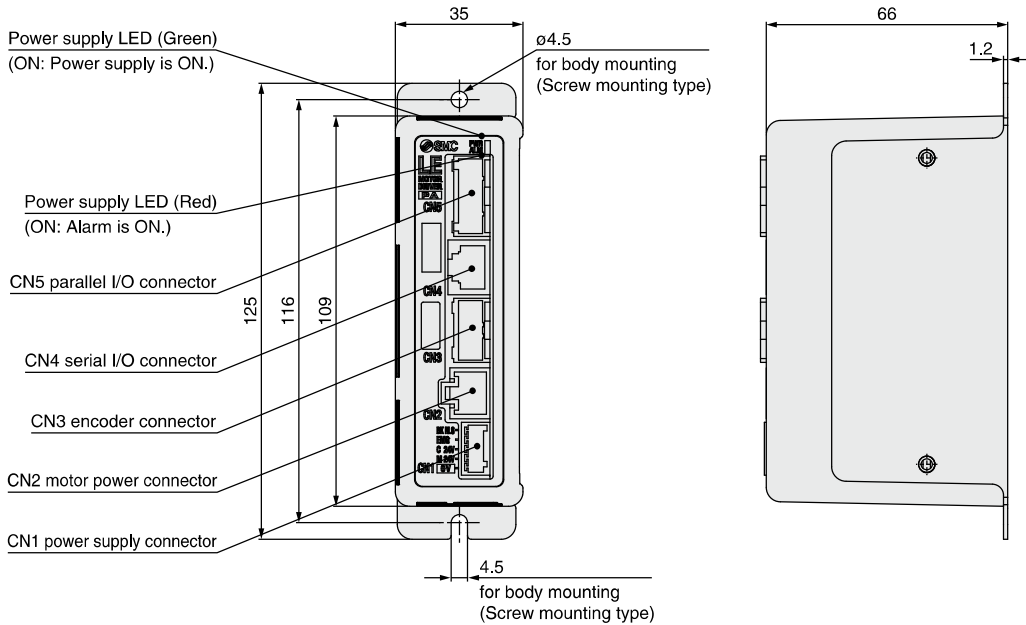

### b) DIN rail mounting (LECPA□□D-□)

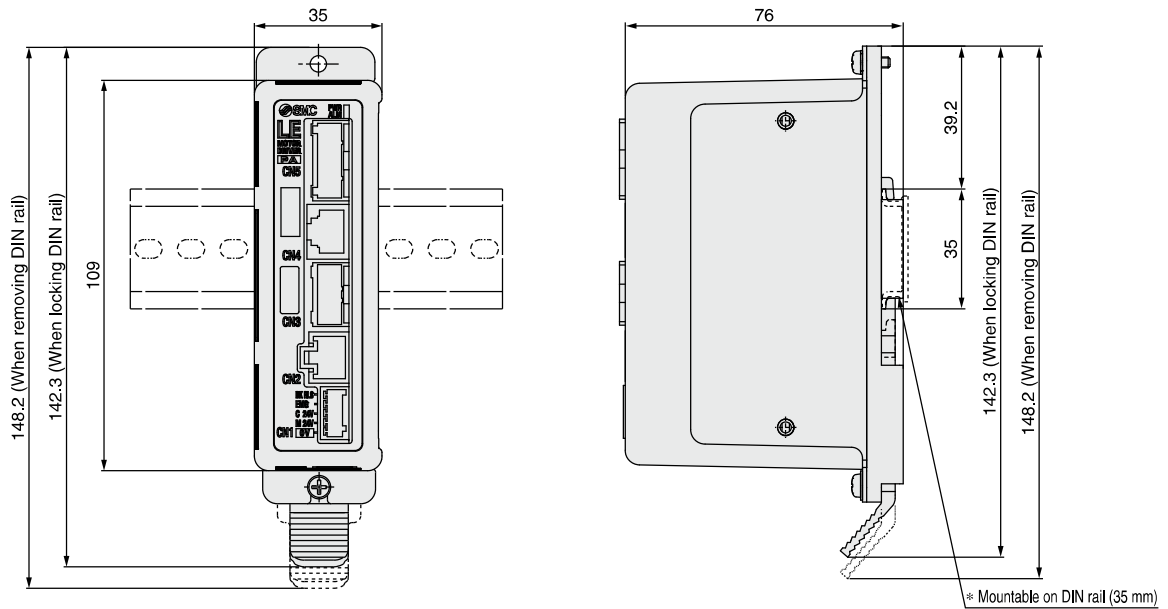

## Wiring Example 1

### Power Supply Connector: CN1

\* Power supply plug is an accessory.  
 <Applicable cable size> AWG20 (0.5 mm<sup>2</sup>), cover diameter 2.0 mm or less

### CN1 Power Supply Connector Terminal for LECPA (PHOENIX CONTACT FK-MC0.5/5-ST-2.5)

Terminal name	Function	Details
0V	Common supply (-)	M 24V terminal/C 24V terminal/EMG terminal/BK RLS terminal are common (-).
M 24V	Motor power supply (+)	Motor power supply (+) supplied to the driver
C 24V	Control power supply (+)	Control power supply (+) supplied to the driver
EMG	Stop (+)	Input (+) for releasing the stop
BK RLS	Lock release (+)	Input (+) for releasing the lock

### Power supply plug for LECPA: LEC-D-1-1

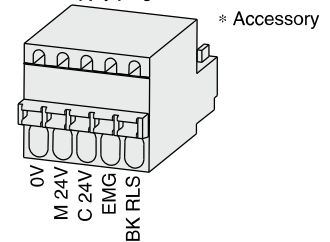

## Wiring Example 2

### Parallel I/O Connector: CN5

\* When you connect a PLC, etc., to the CN5 parallel I/O connector, please use the I/O cable (LEC-CL5-□).  
 \* The wiring should be changed depending on the type of the parallel I/O (NPN or PNP).

#### LECPAN□□-□ (NPN)

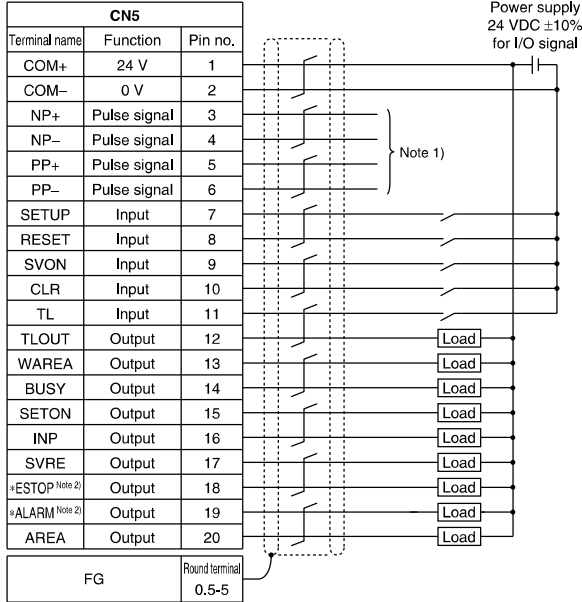

#### LECPAP□□-□ (PNP)

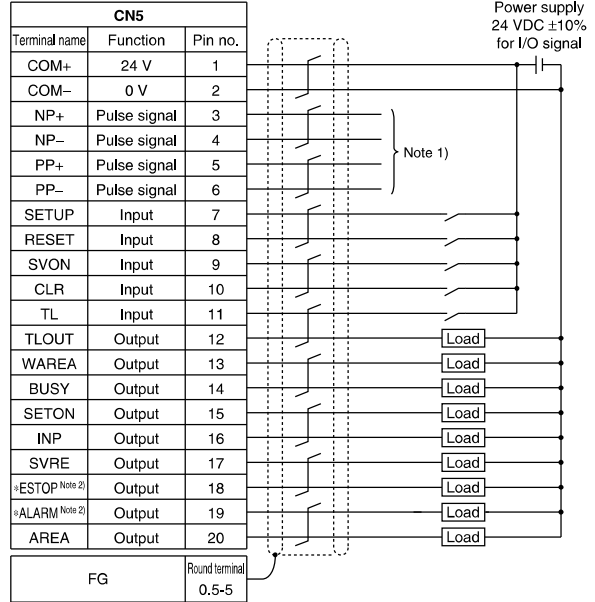

Note 1) For pulse signal wiring method, refer to "Pulse Signal Wiring Details".  
 Note 2) Output when the power supply of the driver is ON, (N.C.)

#### Input Signal

Name	Details
COM+	Connects the power supply 24 V for input/output signal
COM-	Connects the power supply 0 V for input/output signal
SETUP	Instruction to return to origin
RESET	Alarm reset
SVON	Servo ON instruction
CLR	Deviation reset
TL	Instruction to pushing operation

#### Output Signal

Name	Details
BUSY	Outputs when the actuator is operating
SETON	Outputs when returning to origin
INP	Outputs when target position is reached
SVRE	Outputs when servo is on
*ESTOP (Note 3)	Not output when EMG stop is instructed
*ALARM (Note 3)	Not output when alarm is generated
AREA	Outputs within the area output setting range
WAREA	Outputs within W-AREA output setting range
TLOUT	Outputs during pushing operation

Note 3) Signal of negative-logic circuit ON (N.C.)

## Pulse Signal Wiring Details

### •Pulse signal output of positioning unit is differential output

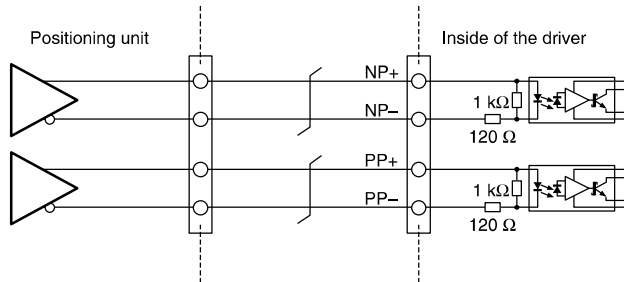

### •Pulse signal output of positioning unit is open collector output

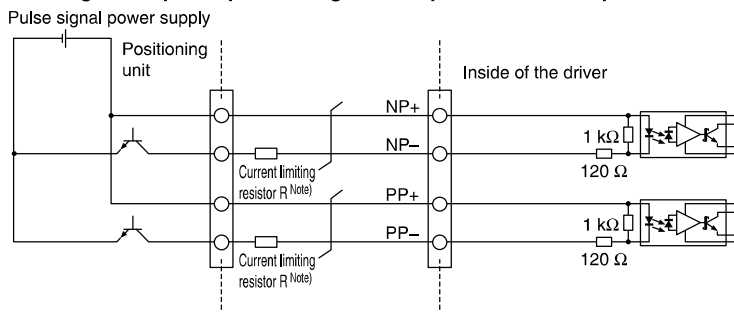

Note) Connect the current limiting resistor R in series to correspond to the pulse signal voltage.

Pulse signal power supply voltage	Current limiting resistor R specifications	Current limiting resistor part no.
24 VDC ±10%	3.3 kΩ ±5% (0.5 W or more)	LEC-PA-R-332
5 VDC ±5%	390 Ω ±5% (0.1 W or more)	LEC-PA-R-391

# LECPA Series

## Signal Timing

### Return to Origin

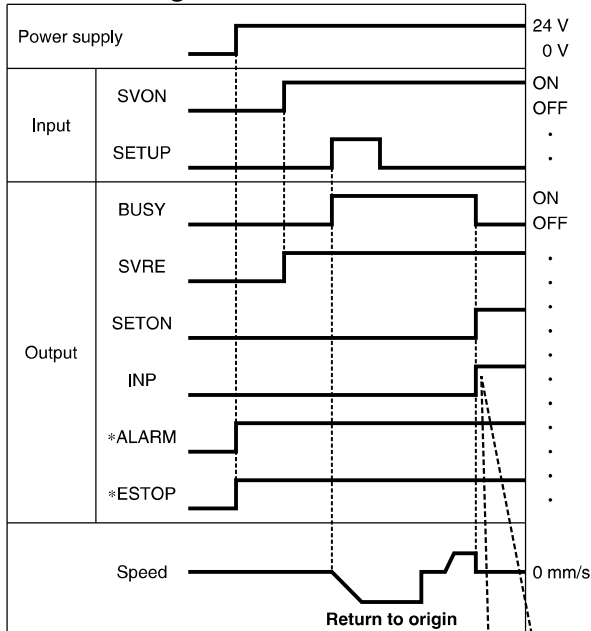

If the actuator is within the "In position" range of the basic parameter, INP will turn ON, but if not, it will remain OFF.

\* \*ALARM" and \*ESTOP" are expressed as negative-logic circuit.

### Positioning Operation

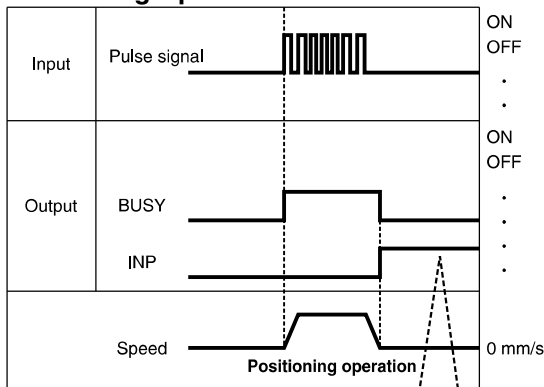

If the actuator is within the "In position" range of the step data, INP will turn ON, but if not, it will remain OFF.

### Pushing Operation

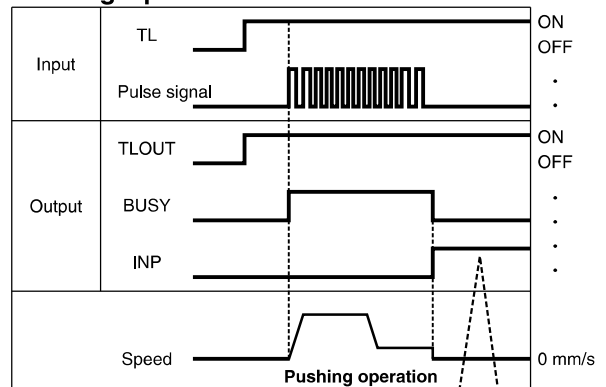

If the current pushing force exceeds the "Trigger LV" value of the step data, INP signal will turn ON.

Note) If pushing operation is stopped when there is no pulse deviation, the moving part of the actuator may pulsate.

### Alarm Reset

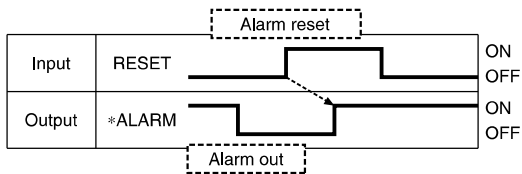

\* \*ALARM" is expressed as negative-logic circuit.

**Options: Actuator Cable**

[Robotic cable, standard cable for step motor (Servo/24 VDC)]

**LE-CP-1** - [ ]

Cable length (L) [m]

1	1.5
3	3
5	5
8	8*
A	10*
B	15*
C	20*

\* Produced upon receipt of order (Robotic cable only)

Cable type

Nil	Robotic cable (Flexible cable)
S	Standard cable

**Weight**

Product no.	Weight [g]	Note
LE-CP-1-S	190	Standard cable
LE-CP-3-S	280	
LE-CP-5-S	460	
LE-CP-1	140	Robotic cable
LE-CP-3	260	
LE-CP-5	420	
LE-CP-8	790	
LE-CP-A	980	
LE-CP-B	1460	
LE-CP-C	1940	

**LE-CP- $\frac{1}{5}$** /Cable length: 1.5 m, 3 m, 5 m

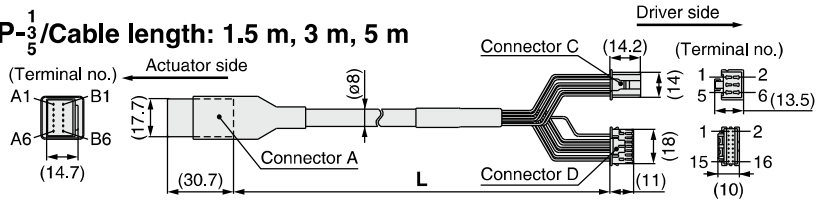

**LE-CP- $\frac{8}{AC}$** /Cable length: 8 m, 10 m, 15 m, 20 m  
(\* Produced upon receipt of order)

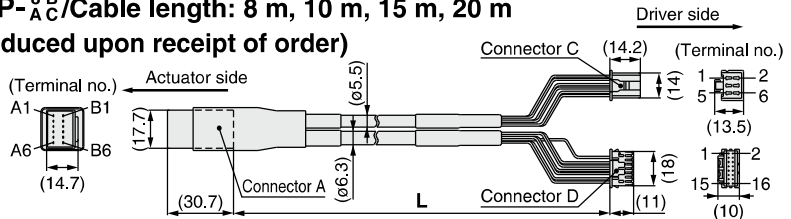

Signal	Connector A terminal no.	Cable color	Connector C terminal no.
A	B-1	Brown	2
A	A-1	Red	1
B	B-2	Orange	6
B	A-2	Yellow	5
COM-A/COM	B-3	Green	3
COM-B/-	A-3	Blue	4
Shield			
Vcc	B-4	Brown	12
GND	A-4	Black	13
A	B-5	Red	7
A	A-5	Black	6
B	B-6	Orange	9
B	A-6	Black	8
		-	3

[Robotic cable, standard cable with lock and sensor for step motor (Servo/24 VDC)]

**LE-CP-1-B** - [ ]

Cable length (L) [m]

1	1.5
3	3
5	5
8	8*
A	10*
B	15*
C	20*

\* Produced upon receipt of order (Robotic cable only)

With lock and sensor

Cable type

Nil	Robotic cable (Flexible cable)
S	Standard cable

**Weight**

Product no.	Weight [g]	Note
LE-CP-1-B-S	240	Standard cable
LE-CP-3-B-S	380	
LE-CP-5-B-S	630	
LE-CP-1-B	190	Robotic cable
LE-CP-3-B	360	
LE-CP-5-B	590	
LE-CP-8-B	1060	
LE-CP-A-B	1320	
LE-CP-B-B	1920	
LE-CP-C-B	2620	

**LE-CP- $\frac{1}{5}$** /Cable length: 1.5 m, 3 m, 5 m

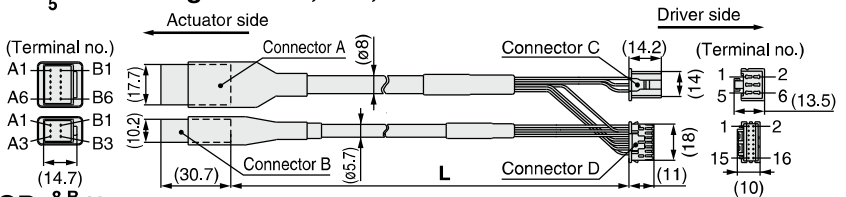

**LE-CP- $\frac{8}{AC}$** /Cable length: 8 m, 10 m, 15 m, 20 m  
(\* Produced upon receipt of order)

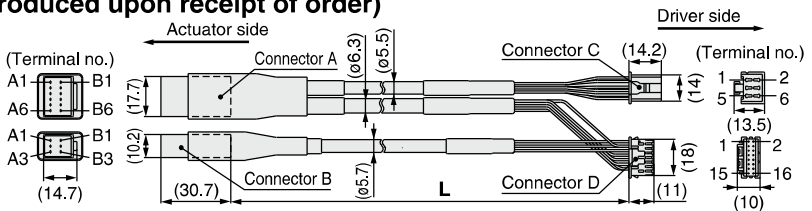

Signal	Connector A terminal no.	Cable color	Connector C terminal no.
A	B-1	Brown	2
A	A-1	Red	1
B	B-2	Orange	6
B	A-2	Yellow	5
COM-A/COM	B-3	Green	3
COM-B/-	A-3	Blue	4
Shield			
Vcc	B-4	Brown	12
GND	A-4	Black	13
A	B-5	Red	7
A	A-5	Black	6
B	B-6	Orange	9
B	A-6	Black	8
		-	3

Signal	Connector B terminal no.	Cable color	Connector D terminal no.
Lock (+)	B-1	Red	4
Lock (-)	A-1	Black	5
Sensor (+)	B-3	Brown	1
Sensor (-)	A-3	Blue	2

# LECPA Series

## Options

[I/O cable]

### LEC-C L5 - 1

I/O cable type	
L5	For LECPA

I/O cable length (L)	
1	1.5 m
3	3 m*
5	5 m*

\* Pulse input usable only with differential. Only 1.5 m cables usable with open collector.

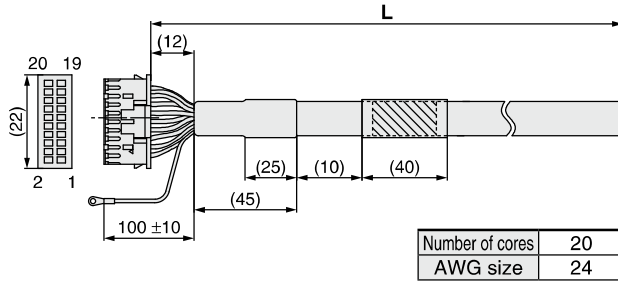

Pin no.	Insulation color	Dot mark	Dot color
1	Light brown	■	Black
2	Light brown	■	Red
3	Yellow	■	Black
4	Yellow	■	Red
5	Light green	■	Black
6	Light green	■	Red
7	Gray	■	Black
8	Gray	■	Red
9	White	■	Black
10	White	■	Red
11	Light brown	■ ■	Black

Pin no.	Insulation color	Dot mark	Dot color
12	Light brown	■ ■	Red
13	Yellow	■ ■	Black
14	Yellow	■ ■	Red
15	Light green	■ ■	Black
16	Light green	■ ■	Red
17	Gray	■ ■	Black
18	Gray	■ ■	Red
19	White	■ ■	Black
20	White	■ ■	Red
Round terminal 0.5-5	Green		

### Weight

Product no.	Weight [g]
LEC-CL5-1	190
LEC-CL5-3	370
LEC-CL5-5	610

[Noise filter set]

Step Motor Driver (Pulse Input Type)

### LEC-NFA

Contents of the set: 2 noise filters

(Manufactured by WURTH ELEKTRONIK: 74271222)

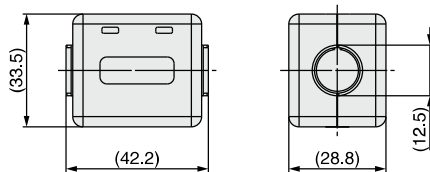

\* Refer to the LECPA series Operation Manual for installation.

[Current limiting resistor]

This optional resistor (LEC-PA-R-□) is used when the pulse signal output of the positioning unit is open collector output.

### LEC-PA-R-□

Current limiting resistor

Symbol	Resistance	Pulse signal power supply voltage
332	3.3 kΩ ±5%	24 VDC ±10%
391	390 Ω ±5%	5 VDC ±5%

- \* Select a current limiting resistor that corresponds to the pulse signal power supply voltage.
- \* For the LEC-PA-R-□, two pieces are shipped as a set.
- \* For pulse signal wiring details, refer to page 593.

# LEC Series

# Communication Cable for Controller Setting/LEC-W2A-□

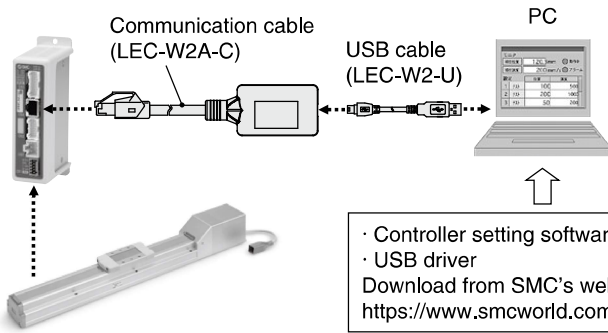

## How to Order

**LEC-W2A-C**

Communication cable

**LEC-W2-U**

USB cable

## Compatible Controller/Driver

Step data input type	LECP6 Series/LECA6 Series
Pulse input type	LECPA Series
CC-Link direct input type	LECPMJ Series
Step Motor Controller	JXCE1/91/P1/D1/L1 Series

\* When connecting to a JXCE1/91/P1/D1/L1 series product, use a conversion cable (P5062-5) as a relay.

## Hardware Requirements

OS	Windows®7, Windows®8.1, Windows®10
Communication interface	USB 1.1 or USB 2.0 ports
Display	1024 x 768 or more

\* Windows®7, Windows®8.1 and Windows®10 are registered trademarks of Microsoft Corporation in the United States.

## Screen Example

### Easy mode screen example

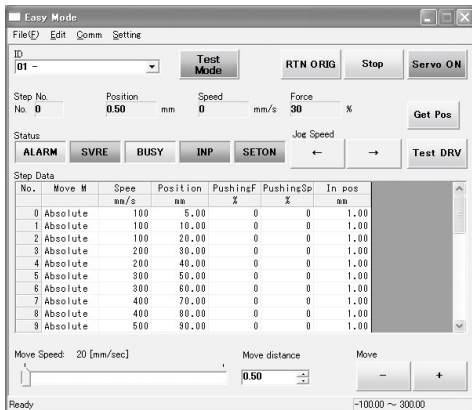

### Normal mode screen example

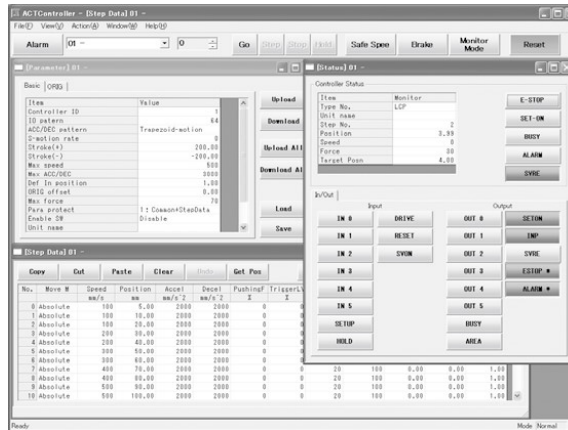

### Easy operation and simple setting

- Allowing to set and display actuator step data such as position, speed, force, etc.
- Setting of step data and test drive can be performed on the same page.
- Can be used to jog and move at a constant rate.

### Detailed setting

- Step data can be set in detail.
- Signals and terminal status can be monitored.
- Parameters can be set.
- JOG and constant rate movement, return to origin, test drive and testing of forced output can be performed.

## How to Order



LEC-T1-3 J G

Teaching box

Cable length [m]  
3 3

Initial language

J	Japanese
E	English

Enable switch

Nil	None
S	Equipped with enable switch

\* Interlock switch for jog and test function

Stop switch

G	Equipped with stop switch
---	---------------------------

\* The displayed language can be changed to English or Japanese.

## Specifications

Item	Description
Switch	Stop switch, Enable switch (Option)
Cable length [m]	3
Enclosure	IP64 (Except connector)
Operating temperature range [°C]	5 to 50
Operating humidity range [%RH]	90 or less (No condensation)
Weight [g]	350 (Except cable)

### [CE-compliant products]

The EMC compliance of the teaching box was tested with the LECP6 series step motor controller (servo/24 VDC) and an applicable actuator.

### [UL-compliant products]

When conformity to UL is required, the electric actuator and driver should be used with a UL1310 Class 2 power supply.

### Standard functions

- Chinese character display
- Stop switch is provided.

### Option

- Enable switch is provided.

## Easy Mode

Function	Details
Step data	• Setting of step data
Jog	• Jog operation • Return to origin
Test	• 1 step operation <sup>Note 1)</sup> • Return to origin
Monitor	• Display of axis and step data no. • Display of two items selected from Position, Speed, Force.
ALM	• Active alarm display • Alarm reset
TB setting	• Reconnection of axis (Ver. 1.**) • Displayed language setting (Ver. 2.**) • Setting of easy/normal mode • Setting step data and selection of items from easy mode monitor

### Menu Operations Flowchart

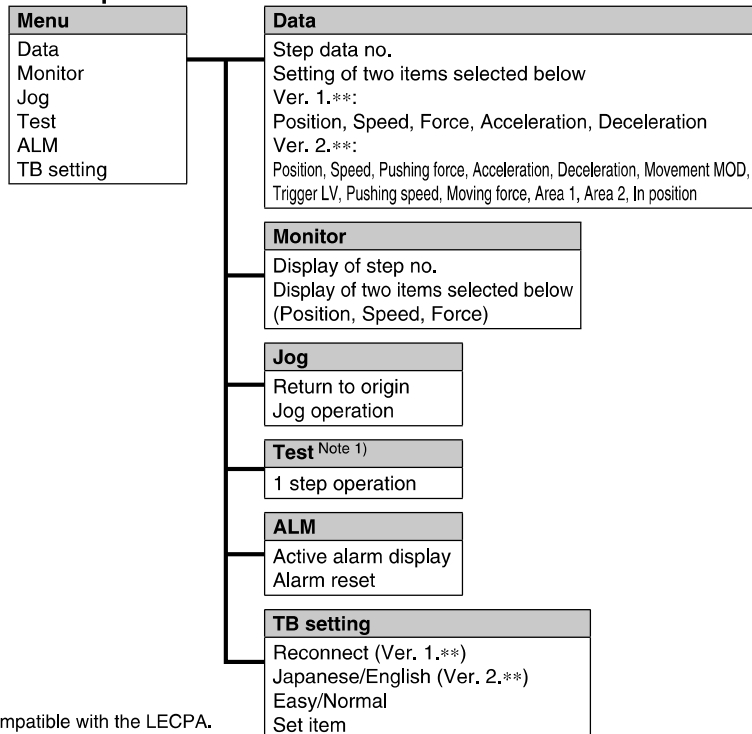

Note 1) Not compatible with the LECPA.

## Normal Mode

Function	Details
Step data	• Step data setting
Parameter	• Parameters setting
Test	<ul style="list-style-type: none"> <li>• Jog operation/Constant rate movement</li> <li>• Return to origin</li> <li>• Test drive <sup>Note 1)</sup></li> </ul> (Specify a maximum of 5 step data and operate.) <ul style="list-style-type: none"> <li>• Forced output (Forced signal output, Forced terminal output) <sup>Note 2)</sup></li> </ul>
Monitor	<ul style="list-style-type: none"> <li>• Drive monitor</li> <li>• Output signal monitor <sup>Note 2)</sup></li> <li>• Input signal monitor <sup>Note 2)</sup></li> <li>• Output terminal monitor</li> <li>• Input terminal monitor</li> </ul>
ALM	<ul style="list-style-type: none"> <li>• Active alarm display (Alarm reset)</li> <li>• Alarm log record display</li> </ul>
File	<ul style="list-style-type: none"> <li>• Data saving Save the step data and parameters of the driver which is being used for communication (it is possible to save four files, with one set of step data and parameters defined as one file).</li> <li>• Load to driver Loads the data which is saved in the teaching box to the driver which is being used for communication.</li> <li>• Delete the saved data.</li> <li>• File protection (Ver. 2.**)</li> </ul>
TB setting	<ul style="list-style-type: none"> <li>• Display setting (Easy/Normal mode)</li> <li>• Language setting (Japanese/English)</li> <li>• Backlight setting</li> <li>• LCD contrast setting</li> <li>• Beep sound setting</li> <li>• Max. connection axis</li> <li>• Distance unit (mm/inch)</li> </ul>
Reconnect	• Reconnection of axis

## Menu Operations Flowchart

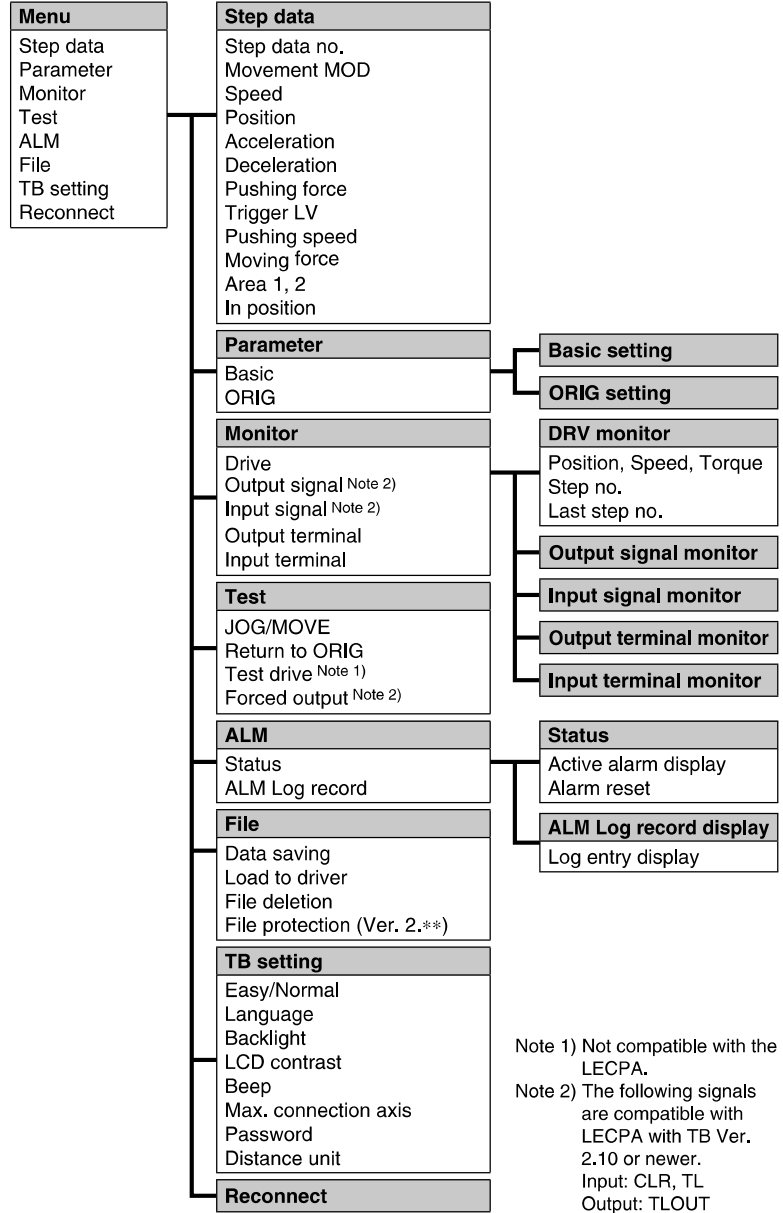

## Dimensions

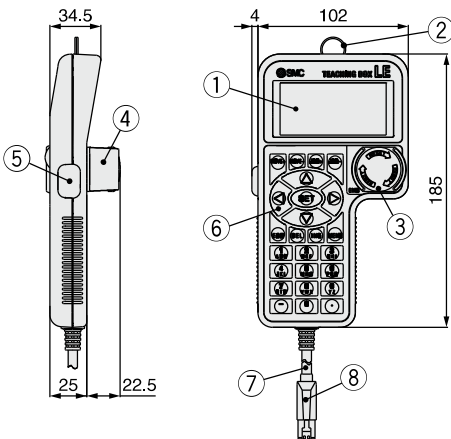

No.	Description	Function
1	LCD	A screen of liquid crystal display (with backlight)
2	Ring	A ring for hanging the teaching box
3	Stop switch	When switch is pushed in, the switch locks and stops. The lock is released when it is turned to the right.
4	Stop switch guard	A guard for the stop switch
5	Enable switch (Option)	Prevents unintentional operation (unexpected operation) of the jog test function. Other functions such as data change are not covered.
6	Key switch	Switch for each input
7	Cable	Length: 3 meters
8	Connector	A connector connected to CN4 of the driver

Compatible actuators

LEF LEL LEM  
LEY LES LEP  
LER LEH

# CC-Link Direct Input Type Step Motor Controller

## LECPMJ Series



### How to Order

**LECPMJ** [ ] [ ] - [ ]

**Controller**

**Compatible motor**

<b>P</b>	Step motor (Servo/24 VDC)
----------	---------------------------

**Controller type**

<b>MJ</b>	CC-Link direct input type
-----------	---------------------------

**Communication plug connector**

<b>Nil</b>	None
<b>S</b>	Straight type
<b>T</b>	T-branch type

**Controller mounting**

<b>Nil</b>	Screw mounting
<b>D</b>	DIN rail mounting

\* DIN rail is not included.  
Order it separately.

**Actuator part number**

Part number except cable specifications and actuator options  
Example: Enter "**LEFS16B-100**"  
for the LEFS16B-100B-S1MJS.

<b>BC</b>	Blank controller <sup>Note)</sup>
-----------	-----------------------------------

Note) The dedicated software (LEC-BCW) is required.



### Communication plug connector

\* Part number that is used when ordering the communication plug connector individually.

**LEC-CMJ-S**

**Controller type**

<b>MJ</b>	CC-Link direct input type
-----------	---------------------------

**Connector type**

<b>S</b>	Straight type
<b>T</b>	T-branch type



Straight type  
LEC-CMJ-S



T-branch type  
LEC-CMJ-T

### The controller is sold as single unit after the compatible actuator is set.

Confirm that the combination of the controller and the actuator is correct.

- ① Check the actuator label for model number. This matches the controller.

LEFS16B-400

①



\* Refer to the operation manual for using the products. Please download it via our website, <http://www.smcworld.com>

### Precautions on blank controller (LECPMJ□□-BC)

Blank controller is a controller to which the customer can write the data of the actuator to be combined and used. Use the dedicated software (LEC-BCW) for data writing.

- Please download the dedicated software (LEC-BCW) via our website.
- Order the communication cable for controller setting (LEC-W2A-C) separately to use this software.

SMC website: <https://www.smcworld.com>

## Specifications

Item		LECPMJ					
<b>Compatible motor</b>		Step motor (Servo/24 VDC)					
<b>Power supply</b> <small>Note 1)</small>		Power voltage: 24 VDC $\pm 10\%$ <small>Note 2)</small>					
<b>Compatible encoder</b>		Incremental A/B phase (800 pulse/rotation)					
<b>Communication specifications</b>	<b>Fieldbus</b>	CC-Link Ver. 1.10					
	<b>Communication speed [bps]</b>	156 k/625 k/2.5 M/5 M/10 M					
	<b>Communication method</b>	Broadcast polling					
	<b>Station type</b>	Remote device station					
	<b>I/O occupation area</b>	1 station ( Input 32 points/4 words ) ( Output 32 points/4 words )	2 stations ( Input 64 points/8 words ) ( Output 64 points/8 words )	4 stations ( Input 128 points/16 words ) ( Output 128 points/16 words )			
	<b>Applicable communication cable</b>		CC-Link Ver. 1.10 compliant cable (Shielded 3-core twisted pair cable) <small>Note 3)</small>				
	<b>Maximum cable length</b>	<b>Communication speed [bps]</b>	156 k	625 k	2.5 M	5 M	10 M
		<b>Total cable length [m]</b>	1200	900	400	160	100
	<b>Serial communication</b>		RS485 (Modbus protocol)				
	<b>Memory</b>		EEPROM				
<b>LED indicator</b>		PWR, ALM, L ERR, L RUN					
<b>Lock control</b>		Forced-lock release terminal <small>Note 4)</small>					
<b>Cable length [m]</b>		Actuator cable: 20 or less					
<b>Cooling system</b>		Natural air cooling					
<b>Operating temperature range [°C]</b>		0 to 40 (No freezing)					
<b>Operating humidity range [%RH]</b>		90 or less (No condensation)					
<b>Storage temperature range [°C]</b>		-10 to 60 (No freezing)					
<b>Storage humidity range [%RH]</b>		90 or less (No condensation)					
<b>Insulation resistance [M<math>\Omega</math>]</b>		Between all of external terminals and the case 50 (500 VDC)					
<b>Weight [g]</b>	<b>Body</b>	170 (Screw mounting), 190 (DIN rail mounting)					
	<b>Communication plug connector</b>	10 (Straight type), 20 (T-branch type)					

Note 1) Do not use the power supply of "inrush current prevention type" for the controller power supply.

When conformity to UL is required, the electric actuator and controller should be used with a UL1310 Class 2 power supply.

Note 2) The power consumption changes depending on the actuator model. Refer to the specifications of actuator for more details.

Note 3) If the system comprises of both CC-Link Ver. 1.00 and Ver. 1.10 compliant cables, Ver. 1.00 specifications are applied to the maximum communication cable length and the cable length between stations.

Note 4) Applicable to non-magnetizing lock.

## Mode explanation

Mode type	Description
<b>Single numeric parameter</b>	Can define numerical data in the Movement MOD and another item in the step data directly from the PLC when starting operation by specifying a registered step data No.
<b>Half numeric parameters</b>	Can define numerical data in the Movement MOD, Speed, Position, Acceleration/Pushing force, Pushing speed, or Deceleration/Trigger LV in the step data directly from the PLC when starting operation by specifying a registered step data No.
<b>Full numeric parameters</b>	Can define numerical data in all step data items, Movement MOD, Speed, Position, Acceleration, Pushing speed, Pushing force, Deceleration, Trigger LV, Moving force, Area 1, Area 2, and In position, directly from the PLC to start operation.

## Function that can be executed in each mode

Mode setting [Number of occupied stations] <small>Note 5)</small>	Single numeric parameter [1]	Half numeric parameters [2]	Full numeric parameters [4]
<b>Step no. defining operation</b>		○	
<b>Numerical data defining operation</b>		○	
<b>Number of definable numerical data items</b>	1	6	12
<b>Monitor of position/speed</b>		○	
<b>Step data editing</b>		○ <small>Note 6)</small>	
<b>Max. number of connectable controllers</b> <small>Note 7)</small>	42	32	16

Note 5) The modes can be set by registering the number of occupied stations with basic parameter "Option setting 1" of the controller.

Note 6) It is possible to edit it from teaching box/controller setting software for "Single numeric parameter". It is possible to edit it from teaching box/controller setting software and PLC (CC-Link) for "Half numeric parameters" and "Full numeric parameters".

Note 7) Maximum number of units specified in CC-Link communication specifications.

# LECPMJ Series

## Specifications

### Modifiable step data item in each mode

●: Numerical data modifiable items

Mode setting	Step data item											
	Movement MOD	Speed	Position	Acceleration	Pushing force	Pushing speed	Deceleration	Trigger LV	Moving force	Area 1	Area 2	In position
Single numeric parameter	●	← Only one item can be changed from 11 items, ranging from Speed to In position. →										
Half numeric parameters	●	●	●	← Only one item can be changed from Acceleration/Pushing force. →		●	← Only one item can be changed from Deceleration/Trigger LV. →					
Full numeric parameters	●	●	●	●	●	●	●	●	●	●	●	●

Note) Step data items, except items that have been changed, reference data registered in the controller.

Note) Refer to the LECPMJ operation manual for details of the step data items.

### Operation example: Single numeric parameter



Controller [LECPMJ]

#### [Step data registered in LECPMJ]

No.	Movement MOD	Speed	Position	Acceleration	Deceleration	Pushing force	Trigger LV	Pushing speed	Moving force	Area 1	Area 2	In position
0	1: Absolute	100	10	3000	3000	0	0	0	100	0	0	0.50
1	1: Absolute	100	100	3000	3000	0	0	0	100	0	0	0.50
2	1: Absolute	100	200	3000	3000	0	0	0	100	0	0	0.50

Note) The step data input range changes depending on the actuator model. For details, refer to the operation manual for actuator.

Note) To register the step data, use the controller setting software, teaching box, or data editing function of the LECPMJ.

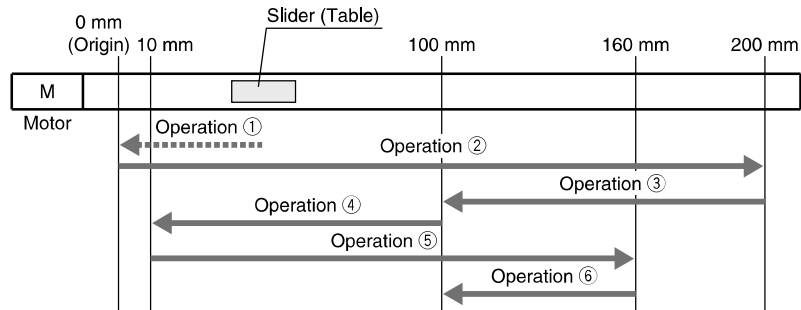

Operations	Description	Position after operation [mm]
Operation ① [Return to origin]	After the servo is turned ON and the SETUP signal is sent, the return to origin will start. After returning to the origin position, the SETON and INP signals are output.	0
Operation ② [Specify Step No.2 to input the DRIVE signal.]		Absolute: 200
Operation ③ [Specify Step No.1 to input the DRIVE signal.]	<b>Step data No. defining operation</b> The operation starts by specifying a registered step data No. to input the DRIVE signal.	200
Operation ④ [Specify Step No.0 to input the DRIVE signal.]		Absolute: 100
Operation ⑤ [Define numerical data in the Movement MOD and Position in Step No.1.] • Movement MOD: 2 (Relative) and Position: 150 are defined from the PLC.		Absolute: 10
Operation ⑥ [Specify Step No.1 to input the DRIVE signal.]	<b>Numerical data defining operation</b> The operation starts by changing the Movement MOD and Position in step data No.1 temporarily by defining numerical data from the PLC.  <b>Step data No. defining operation</b> The operation starts by specifying a registered step data No. to input the DRIVE signal. * Change of numerical values when defining numerical data will not affect the registered step data.	10
		Relative: 150
		160
		Absolute: 100
		100

## Dimensions

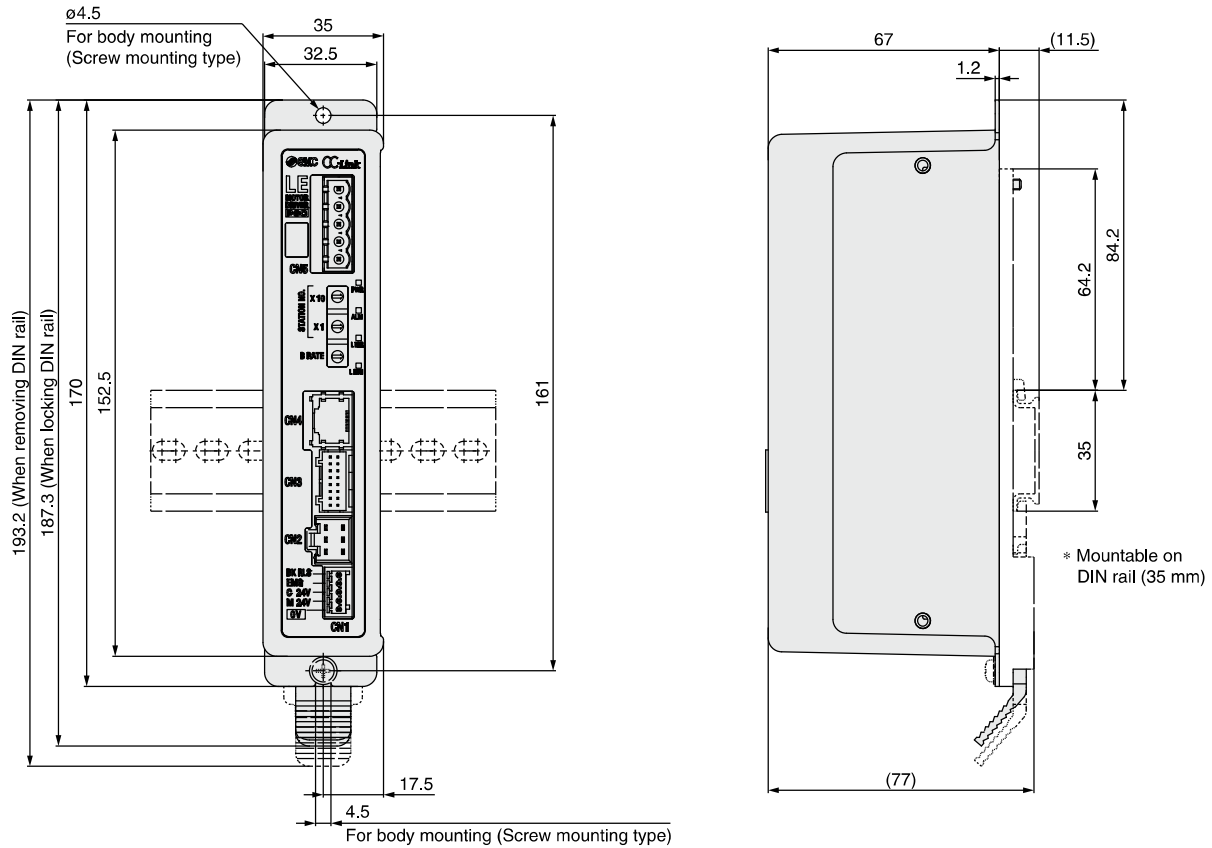

### DIN rail

#### AXT100-DR-□

\* For □, enter a number from the "No." line in the table below.  
Refer to the dimensions above for the mounting dimensions.

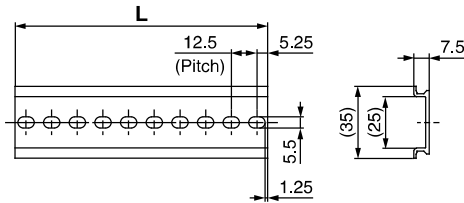

#### L Dimension [mm]

No.	1	2	3	4	5	6	7	8	9	10	11	12	13	14	15	16	17	18	19	20
L	23	35.5	48	60.5	73	85.5	98	110.5	123	135.5	148	160.5	173	185.5	198	210.5	223	235.5	248	260.5
No.	21	22	23	24	25	26	27	28	29	30	31	32	33	34	35	36	37	38	39	40
L	273	285.5	298	310.5	323	335.5	348	360.5	373	385.5	398	410.5	423	435.5	448	460.5	473	485.5	498	510.5

## Wiring Example

### Power Supply Connector: CN1

\* Power supply plug is an accessory.  
<Applicable cable size> AWG20 (0.5 mm<sup>2</sup>), cover diameter 2.0 mm or less

#### CN1 Power Supply Connector Terminal for LECPMJ (PHOENIX CONTACT FK-MC0.5/5-ST-2.5)

Terminal name	Function	Details
0V	Common supply (-)	M 24V terminal/C 24V terminal/EMG terminal/BK RLS terminal are common (-).
M 24V	Motor power supply (+)	Motor power supply (+) supplied to the driver
C 24V	Control power supply (+)	Control power supply (+) supplied to the driver
EMG	Stop (+)	Input (+) for releasing the stop
BK RLS	Lock release (+)	Input (+) for releasing the lock

### Power supply plug for LECPMJ: LEC-D-1-1

\* Accessory

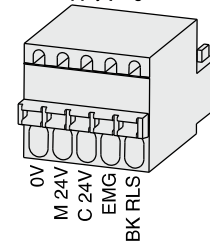

# LECPMJ Series

## Options: Actuator Cable

[Robotic cable, standard cable for step motor (Servo/24 VDC)]

**LE-CP-1** - [ ]

Cable length (L) [m]

1	1.5
3	3
5	5
8	8*
A	10*
B	15*
C	20*

\* Produced upon receipt of order (Robotic cable only)

Cable type

Nil	Robotic cable (Flexible cable)
S	Standard cable

### Weight

Product no.	Weight [g]	Note
LE-CP-1-S	190	Standard cable
LE-CP-3-S	280	
LE-CP-5-S	460	
LE-CP-1	140	Robotic cable
LE-CP-3	260	
LE-CP-5	420	
LE-CP-8	790	
LE-CP-A	980	
LE-CP-B	1460	
LE-CP-C	1940	

**LE-CP- $\frac{1}{5}$** /Cable length: 1.5 m, 3 m, 5 m

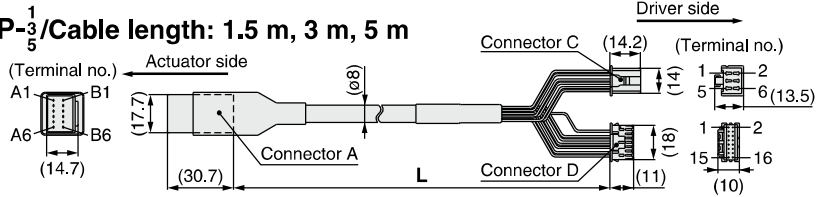

**LE-CP- $\frac{8}{A-C}$** /Cable length: 8 m, 10 m, 15 m, 20 m  
(\* Produced upon receipt of order)

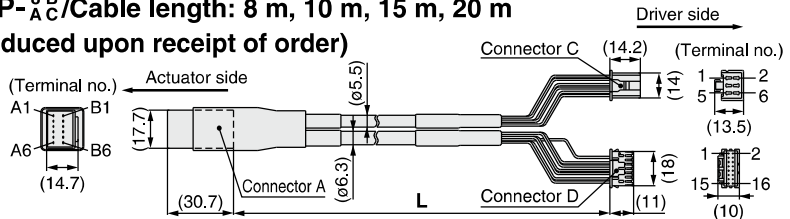

Signal	Connector A terminal no.	Cable color	Connector C terminal no.
A	B-1	Brown	2
A	A-1	Red	1
B	B-2	Orange	6
B	A-2	Yellow	5
COM-A/COM	B-3	Green	3
COM-B/-	A-3	Blue	4
Shield			
Vcc	B-4	Brown	12
GND	A-4	Black	13
A	B-5	Red	7
A	A-5	Black	6
B	B-6	Orange	9
B	A-6	Black	8
		-	3

[Robotic cable, standard cable with lock and sensor for step motor (Servo/24 VDC)]

**LE-CP-1-B** - [ ]

Cable length (L) [m]

1	1.5
3	3
5	5
8	8*
A	10*
B	15*
C	20*

\* Produced upon receipt of order (Robotic cable only)

With lock and sensor

Cable type

Nil	Robotic cable (Flexible cable)
S	Standard cable

### Weight

Product no.	Weight [g]	Note
LE-CP-1-B-S	240	Standard cable
LE-CP-3-B-S	380	
LE-CP-5-B-S	630	
LE-CP-1-B	190	Robotic cable
LE-CP-3-B	360	
LE-CP-5-B	590	
LE-CP-8-B	1060	
LE-CP-A-B	1320	
LE-CP-B-B	1920	
LE-CP-C-B	2620	

**LE-CP- $\frac{1}{5}$** /Cable length: 1.5 m, 3 m, 5 m

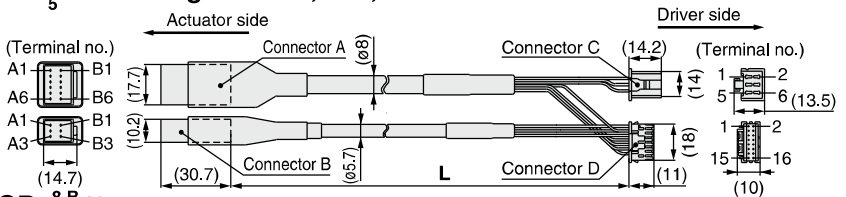

**LE-CP- $\frac{8}{A-C}$** /Cable length: 8 m, 10 m, 15 m, 20 m  
(\* Produced upon receipt of order)

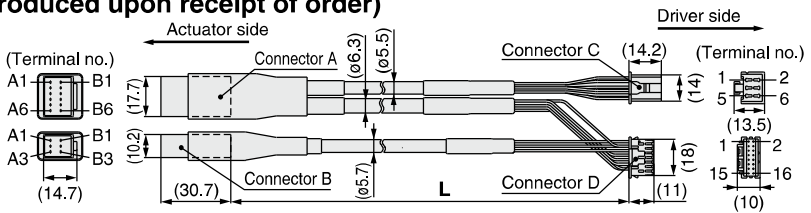

Signal	Connector A terminal no.	Cable color	Connector C terminal no.
A	B-1	Brown	2
A	A-1	Red	1
B	B-2	Orange	6
B	A-2	Yellow	5
COM-A/COM	B-3	Green	3
COM-B/-	A-3	Blue	4
Shield			
Vcc	B-4	Brown	12
GND	A-4	Black	13
A	B-5	Red	7
A	A-5	Black	6
B	B-6	Orange	9
B	A-6	Black	8
		-	3

Signal	Connector B terminal no.	Cable color	Connector D terminal no.
Lock (+)	B-1	Red	4
Lock (-)	A-1	Black	5
Sensor (+)	B-3	Brown	1
Sensor (-)	A-3	Blue	2

# LEC Series

# Communication Cable for Controller Setting/LEC-W2A-□

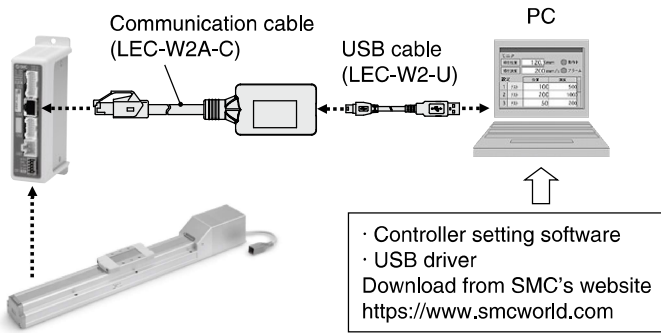

## How to Order

**LEC-W2A-C**

Communication cable

**LEC-W2-U**

USB cable

## Compatible Controller/Driver

Step data input type	LECP6 Series/LECA6 Series
Pulse input type	LECPA Series
CC-Link direct input type	LECPMJ Series
Step Motor Controller	JXCE1/91/P1/D1/L1 Series

\* When connecting to a JXCE1/91/P1/D1/L1 series product, use a conversion cable (P5062-5) as a relay.

## Hardware Requirements

OS	Windows®7, Windows®8.1, Windows®10
Communication interface	USB 1.1 or USB 2.0 ports
Display	1024 x 768 or more

\* Windows®7, Windows®8.1 and Windows®10 are registered trademarks of Microsoft Corporation in the United States.

## Screen Example

### Easy mode screen example

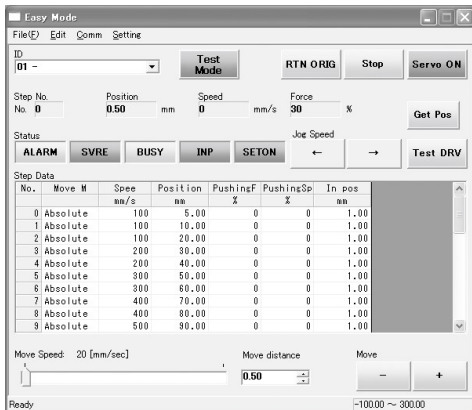

### Easy operation and simple setting

- Allowing to set and display actuator step data such as position, speed, force, etc.
- Setting of step data and test drive can be performed on the same page.
- Can be used to jog and move at a constant rate.

### Normal mode screen example

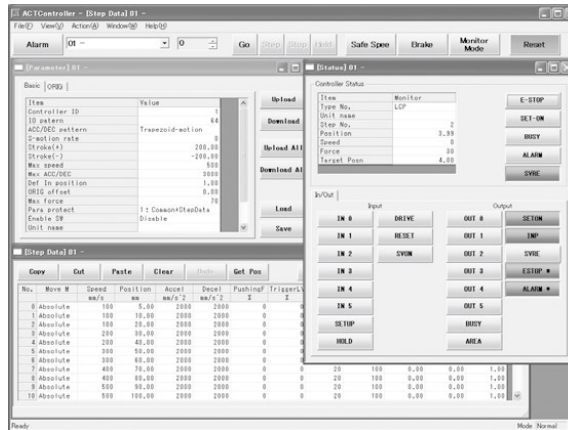

### Detailed setting

- Step data can be set in detail.
- Signals and terminal status can be monitored.
- Parameters can be set.
- JOG and constant rate movement, return to origin, test drive and testing of forced output can be performed.

## How to Order



LEC-T1-3 J G

Teaching box

Cable length [m]  
3 3

Initial language  
J Japanese  
E English

Enable switch

Nil	None
S	Equipped with enable switch

\* Interlock switch for jog and test function

Stop switch

G Equipped with stop switch

\* The displayed language can be changed to English or Japanese.

## Specifications

Item	Description
Switch	Stop switch, Enable switch (Option)
Cable length [m]	3
Enclosure	IP64 (Except connector)
Operating temperature range [°C]	5 to 50
Operating humidity range [%RH]	90 or less (No condensation)
Weight [g]	350 (Except cable)

### [CE-compliant products]

The EMC compliance of the teaching box was tested with the LECP6 series step motor controller (servo/24 VDC) and an applicable actuator.

### [UL-compliant products]

When conformity to UL is required, the electric actuator and driver should be used with a UL1310 Class 2 power supply.

### Standard functions

- Chinese character display
- Stop switch is provided.

### Option

- Enable switch is provided.

## Easy Mode

Function	Details
Step data	• Setting of step data
Jog	• Jog operation • Return to origin
Test	• 1 step operation <sup>Note 1)</sup> • Return to origin
Monitor	• Display of axis and step data no. • Display of two items selected from Position, Speed, Force.
ALM	• Active alarm display • Alarm reset
TB setting	• Reconnection of axis (Ver. 1.**) • Displayed language setting (Ver. 2.**) • Setting of easy/normal mode • Setting step data and selection of items from easy mode monitor

### Menu Operations Flowchart

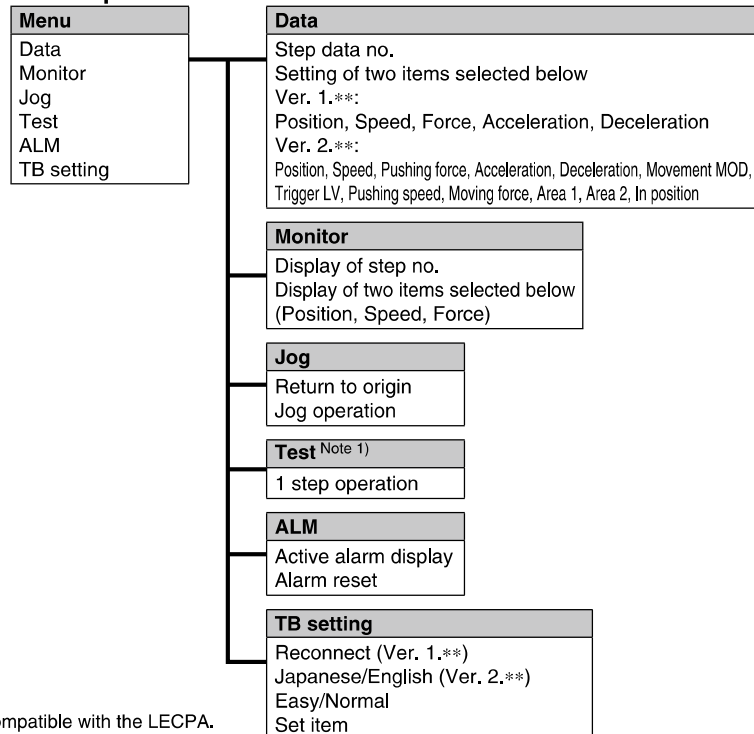

Note 1) Not compatible with the LECPA.

## Normal Mode

Function	Details
Step data	• Step data setting
Parameter	• Parameters setting
Test	<ul style="list-style-type: none"> <li>• Jog operation/Constant rate movement</li> <li>• Return to origin</li> <li>• Test drive <sup>Note 1)</sup></li> </ul> (Specify a maximum of 5 step data and operate.) <ul style="list-style-type: none"> <li>• Forced output (Forced signal output, Forced terminal output) <sup>Note 2)</sup></li> </ul>
Monitor	<ul style="list-style-type: none"> <li>• Drive monitor</li> <li>• Output signal monitor <sup>Note 2)</sup></li> <li>• Input signal monitor <sup>Note 2)</sup></li> <li>• Output terminal monitor</li> <li>• Input terminal monitor</li> </ul>
ALM	<ul style="list-style-type: none"> <li>• Active alarm display (Alarm reset)</li> <li>• Alarm log record display</li> </ul>
File	<ul style="list-style-type: none"> <li>• Data saving Save the step data and parameters of the driver which is being used for communication (it is possible to save four files, with one set of step data and parameters defined as one file).</li> <li>• Load to driver Loads the data which is saved in the teaching box to the driver which is being used for communication.</li> <li>• Delete the saved data.</li> <li>• File protection (Ver. 2.**)</li> </ul>
TB setting	<ul style="list-style-type: none"> <li>• Display setting (Easy/Normal mode)</li> <li>• Language setting (Japanese/English)</li> <li>• Backlight setting</li> <li>• LCD contrast setting</li> <li>• Beep sound setting</li> <li>• Max. connection axis</li> <li>• Distance unit (mm/inch)</li> </ul>
Reconnect	• Reconnection of axis

## Menu Operations Flowchart

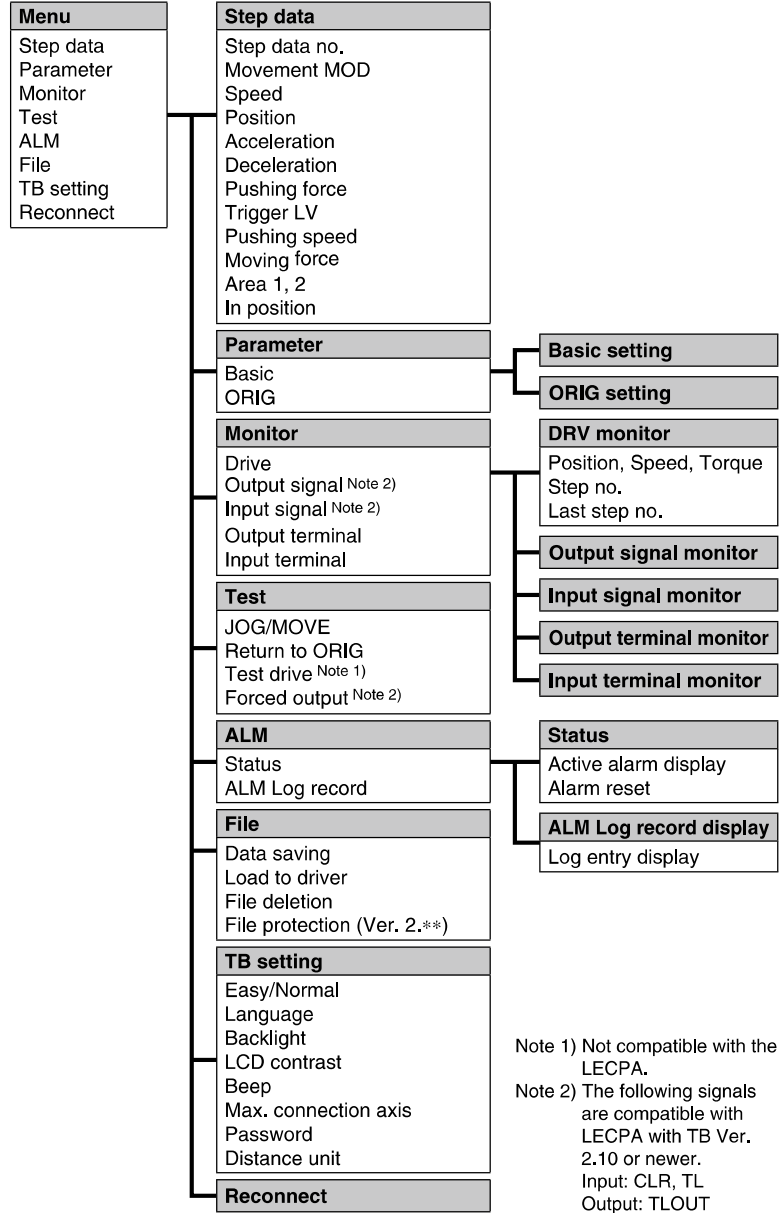

## Dimensions

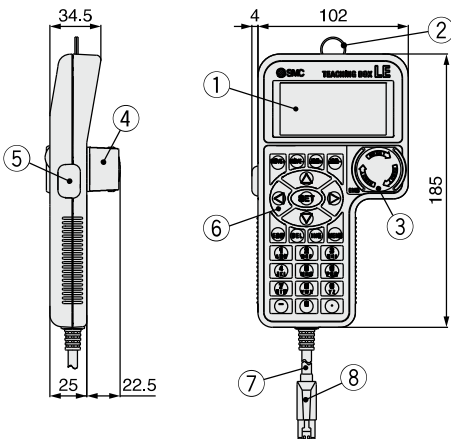

No.	Description	Function
1	<b>LCD</b>	A screen of liquid crystal display (with backlight)
2	<b>Ring</b>	A ring for hanging the teaching box
3	<b>Stop switch</b>	When switch is pushed in, the switch locks and stops. The lock is released when it is turned to the right.
4	<b>Stop switch guard</b>	A guard for the stop switch
5	<b>Enable switch (Option)</b>	Prevents unintentional operation (unexpected operation) of the jog test function. Other functions such as data change are not covered.
6	<b>Key switch</b>	Switch for each input
7	<b>Cable</b>	Length: 3 meters
8	<b>Connector</b>	A connector connected to CN4 of the driver

Compatible actuators

LEF LEL LEM  
LEY LES LEP  
LER LEH

# Step Motor Controller

JXCE1/91/P1/D1/L1 Series



## How to Order

JXC **D** 1 **7** **T** - [ ]

### Communication protocol

<b>E</b>	EtherCAT®
<b>9</b>	EtherNet/IP™
<b>P</b>	PROFINET
<b>D</b>	DeviceNet™
<b>L</b>	IO-Link

For single axis

### Mounting

<b>7</b>	Screw mounting
<b>8*</b>	DIN rail mounting

\* The DIN rail is not included. It must be ordered separately. (Refer to page 603-8.)

### Option

<b>Nil</b>	Without option
<b>S</b>	With straight type DeviceNet™ communication plug for JXCD1
<b>T</b>	With T-branch type DeviceNet™ communication plug for JXCD1

\* Select "Nil" for anything other than JXCD1.



EtherCAT® EtherNet/IP™ PROFINET DeviceNet IO-Link

### Actuator part number

Part number except cable specifications and actuator options  
Example: Enter "LEFS16B-100" for the LEFS16B-100B-S1□□.

**BC** Blank controller (Note)

Note) The dedicated software (JXC-BCW) is required.

### The controller is sold as single unit after the compatible actuator is set.

Confirm that the combination of the controller and the actuator is correct.

- ① Check the actuator label for model number. This matches the controller.

LEFS16B-400

①



\* Refer to the operation manual for using the products. Please download it via our website, <http://www.smcworld.com>

### Precautions on blank controller (JXC□1□□-BC)

Blank controller is a controller to which the customer can write the data of the actuator to be combined and used. Use the dedicated software (JXC-BCW) for data writing.

- Please download the dedicated software (JXC-BCW) via our website.
- Order the controller setting kit (JXC-W2) separately to use this software.

SMC website: <https://www.smcworld.com>

# Step Motor Controller

## JXCE1/91/P1/D1/L1-XZ23 Series

■ Operating temperature range:  
0 to 55°C

■ Communication protocol:

EtherCAT®

PROFINET®

DeviceNet™

EtherNet/IP™

 IO-Link



### How to Order

#### Controller

**JXC D 1 7 T - LEFS16B-100 - XZ23**

#### Precautions for blank controllers (JXC□1□□-BC-XZ23)

A blank controller is a controller to which the customer can write the data of the actuator it is to be combined and used with. Use the dedicated software (JXC-BCW) for data writing.

- Please download the dedicated software (JXC-BCW) via our website.
- Order the controller setting kit (LEC-W2) separately to use this software.

SMC website  
<https://www.smcworld.com>

#### Communication protocol

E	EtherCAT®
9	EtherNet/IP™
P	PROFINET
D	DeviceNet™
L	IO-Link

#### For single axis

#### Mounting

7	Screw mounting
8*1	DIN rail

\*1 The DIN rail is not included. It must be ordered separately.

#### Actuator part number

Without cable specifications and actuator options  
Example: Enter "LEFS16B-100" for the LEFS16B-100B-S1□□.

**BC** Blank controller\*2

\*2 Requires dedicated software (JXC-BCW)

#### Option

Nil	Without option
S	With straight type DeviceNet™ communication plug for JXCD1
T	With T-branch type DeviceNet™ communication plug for JXCD1

\* Select "Nil" for anything other than JXCD1.

### Specifications

Specifications not listed are the same as those of the standard product.

Model	JXC□1-XZ23
Operating temperature range [°C]	0 to 55 (No freezing)

# Step Motor Controller **JXCE1/91/P1/D1/L1 Series**

## Specifications

Model		JXCE1	JXC91	JXCP1	JXCD1	JXCL1
<b>Network</b>		EtherCAT®	EtherNet/IP™	PROFINET	DeviceNet™	IO-Link
<b>Compatible motor</b>		Step motor (Servo/24 VDC)				
<b>Power supply</b>		Power voltage: 24 VDC ±10%				
<b>Current consumption (Controller)</b>		200 mA or less	130 mA or less	200 mA or less	100 mA or less	100 mA or less
<b>Compatible encoder</b>		Incremental A/B phase (800 pulse/rotation)				
<b>Communication specifications</b>	<b>Applicable system</b>	EtherCAT®*2	EtherNet/IP™*2	PROFINET*2	DeviceNet™	IO-Link
	<b>Protocol</b>					
	<b>Version*1</b>	Conformance Test Record V.1.2.6	Volume 1 (Edition 3.14) Volume 2 (Edition 1.15)	Specification Version 2.32	Volume 1 (Edition 3.14) Volume 3 (Edition 1.13)	Version 1.1 Port Class A
	<b>Communication speed</b>	100 Mbps*2	10/100 Mbps*2 (Automatic negotiation)	100 Mbps*2	125/250/500 kbps	230.4 kbps (COM3)
	<b>Configuration file*3</b>	ESI file	EDS file	GSDML file	EDS file	IODD file
	<b>I/O occupation area</b>	Input 20 bytes Output 36 bytes	Input 36 bytes Output 36 bytes	Input 36 bytes Output 36 bytes	Input 4, 10, 20 bytes Output 4, 12, 20, 36 bytes	Input 14 bytes Output 22 bytes
<b>Terminating resistor</b>		Not included				
<b>Memory</b>		EEPROM				
<b>LED indicator</b>		PWR, RUN, ALM, ERR	PWR, ALM, MS, NS	PWR, ALM, SF, BF	PWR, ALM, MS, NS	PWR, ALM, COM
<b>Cable length [m]</b>		Actuator cable: 20 or less				
<b>Cooling system</b>		Natural air cooling				
<b>Operating temperature range [°C]</b>		0 to 40 (No freezing)				
<b>Operating humidity range [%RH]</b>		90 or less (No condensation)				
<b>Insulation resistance [MΩ]</b>		Between all external terminals and the case 50 (500 VDC)				
<b>Weight [g]</b>		220 (Screw mounting) 240 (DIN rail mounting)	210 (Screw mounting) 230 (DIN rail mounting)	220 (Screw mounting) 240 (DIN rail mounting)	210 (Screw mounting) 230 (DIN rail mounting)	190 (Screw mounting) 210 (DIN rail mounting)

\*1 Please note that versions are subject to change.

\*2 Use a shielded communication cable with CAT5 or higher for the PROFINET, EtherNet/IP™, and EtherCAT®.

\*3 The files can be downloaded from the SMC website: <http://www.smcworld.com>

### ■ Trademark

EtherNet/IP™ is a trademark of ODVA.

DeviceNet™ is a trademark of ODVA.

EtherCAT® is registered trademark and patented technology, licensed by Beckhoff Automation GmbH, Germany.

## Example of Operation Command

In addition to the step data input of 64 points maximum in each communication protocol, the changing of each parameter can be performed in real time via numerical data defined operation.

\* Numerical values other than "Moving force," "Area 1," and "Area 2" can be used to perform operation under numerical instructions from JXCL1.

### <Application example> Movement between 2 points

No.	Movement mode	Speed	Position	Acceleration	Deceleration	Pushing force	Trigger LV	Pushing speed	Moving force	Area 1	Area 2	In position
0	1: Absolute	100	10	3000	3000	0	0	0	100	0	0	0.50
1	1: Absolute	100	100	3000	3000	0	0	0	100	0	0	0.50

### <Step no. defined operation>

Sequence 1: Servo ON instruction

Sequence 2: Instruction to return to origin

Sequence 3: Specify step data No. 0 to input the DRIVE signal.

Sequence 4: Specify step data No. 1 after the DRIVE signal has been temporarily turned OFF to input the DRIVE signal.

### <Numerical data defined operation>

Sequence 1: Servo ON instruction

Sequence 2: Instruction to return to origin

Sequence 3: Specify step data No. 0 and turn ON the input instruction flag (position). Input 10 in the target position. Subsequently the start flag turns ON.

Sequence 4: Turn ON step data No. 0 and the input instruction flag (position) to change the target position to 100 while the start flag is ON.

The same operation can be performed with any operation command.

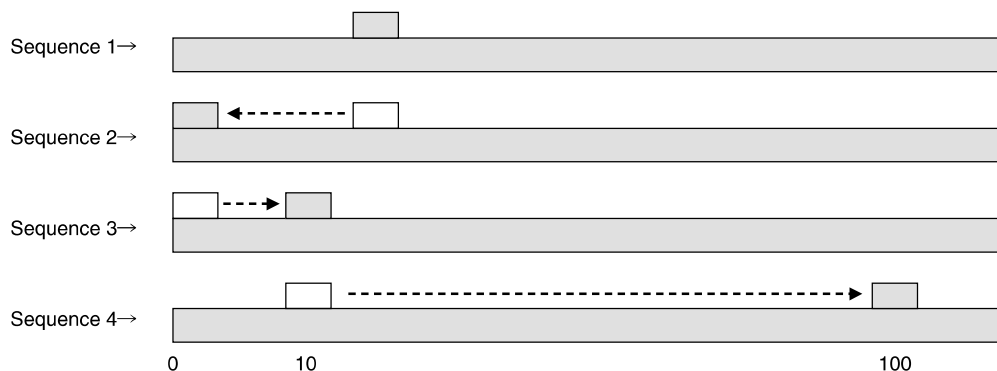

# JXCE1/91/P1/D1/L1 Series

## Dimensions

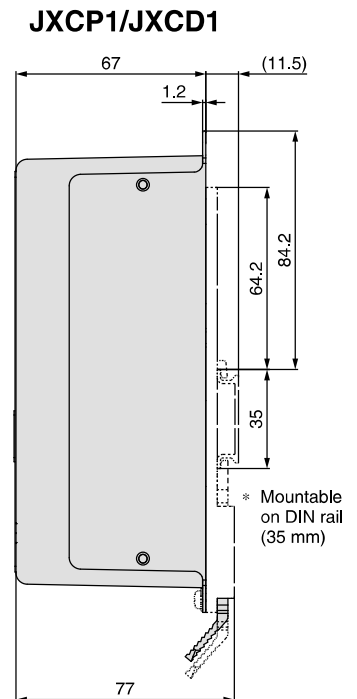
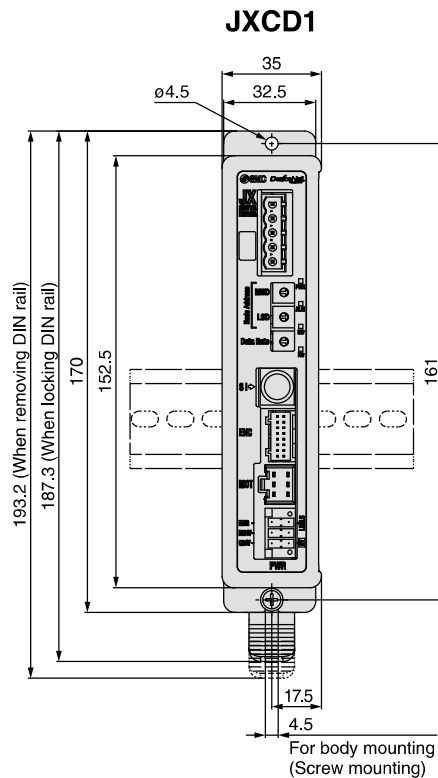
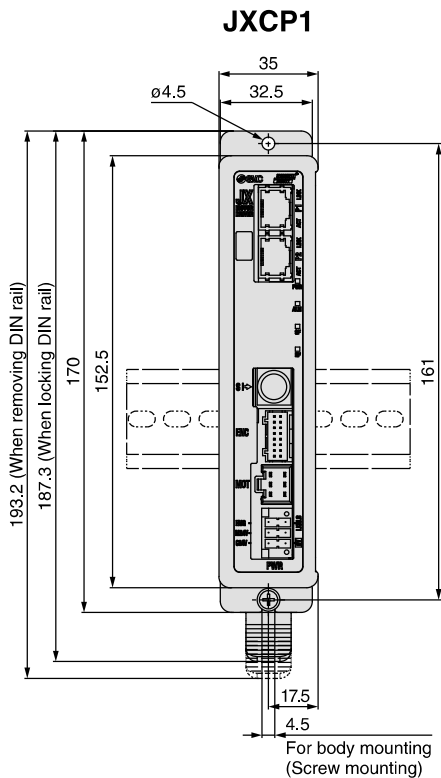
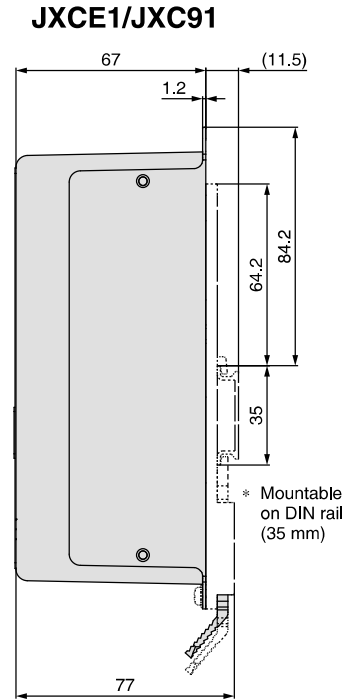
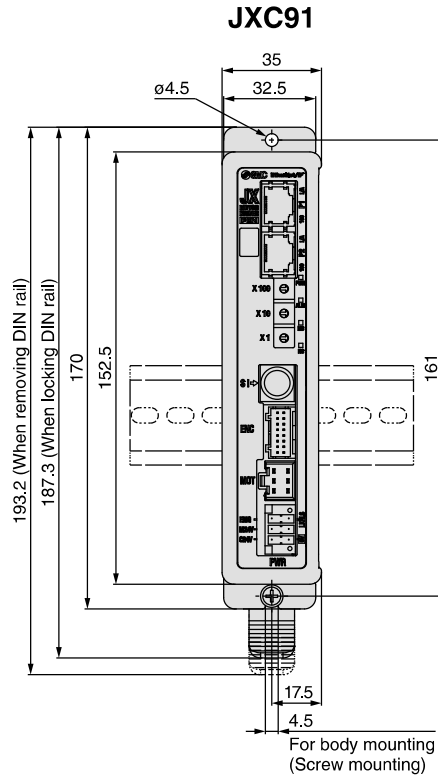
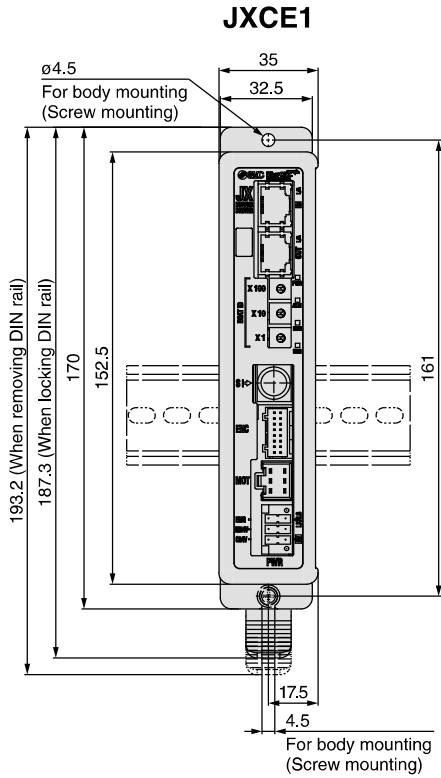

# Step Motor Controller **JXCE1/91/P1/D1/L1 Series**

## Dimensions

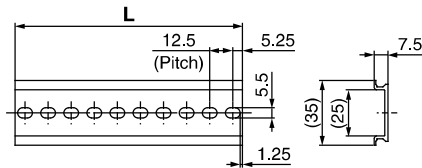
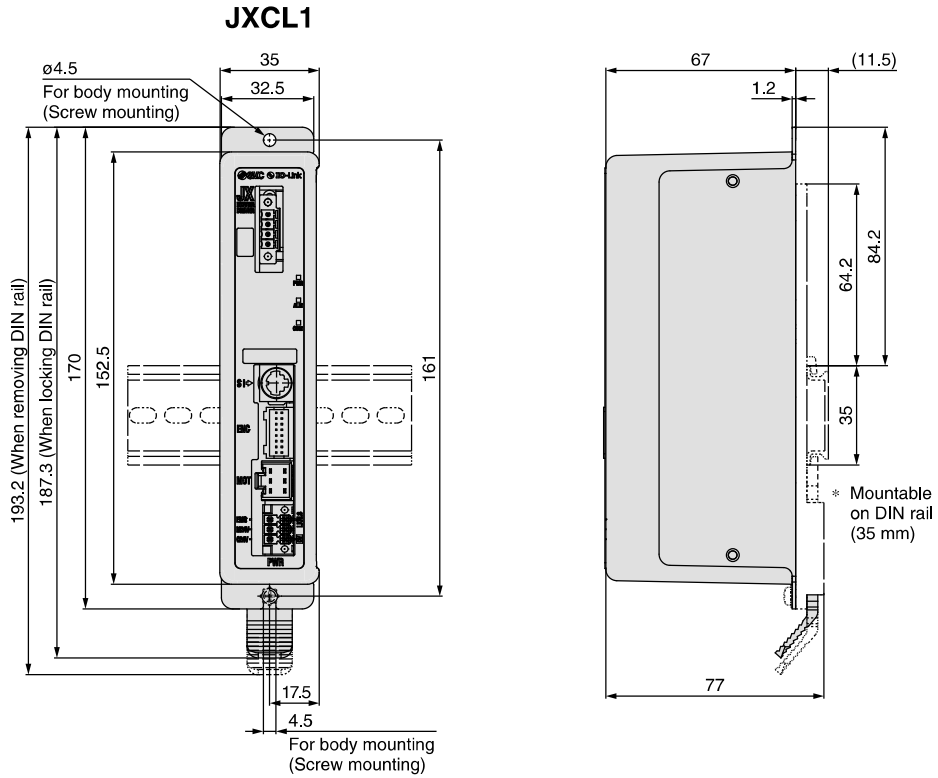

### L Dimensions [mm]

No.	1	2	3	4	5	6	7	8	9	10	11	12	13	14	15	16	17	18	19	20
<b>L</b>	23	35.5	48	60.5	73	85.5	98	110.5	123	135.5	148	160.5	173	185.5	198	210.5	223	235.5	248	260.5
No.	21	22	23	24	25	26	27	28	29	30	31	32	33	34	35	36	37	38	39	40
<b>L</b>	273	285.5	298	310.5	323	335.5	348	360.5	373	385.5	398	410.5	423	435.5	448	460.5	473	485.5	498	510.5

# JXCE1/91/P1/D1 Series

## Options: Actuator Cable

[Robotic cable, standard cable for step motor (Servo/24 VDC)]

**LE-CP-1** - [ ]

Cable length (L) [m]

1	1.5
3	3
5	5
8	8*
A	10*
B	15*
C	20*

\* Produced upon receipt of order (Robotic cable only)

Cable type

Nil	Robotic cable (Flexible cable)
S	Standard cable

### Weight

Product no.	Weight [g]	Note
LE-CP-1-S	190	Standard cable
LE-CP-3-S	280	
LE-CP-5-S	460	
LE-CP-1	140	Robotic cable
LE-CP-3	260	
LE-CP-5	420	
LE-CP-8	790	
LE-CP-A	980	
LE-CP-B	1460	
LE-CP-C	1940	

**LE-CP-3/5** / Cable length: 1.5 m, 3 m, 5 m

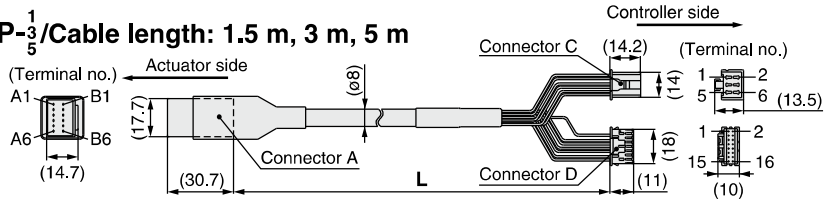

**LE-CP-8 A C** / Cable length: 8 m, 10 m, 15 m, 20 m  
(\* Produced upon receipt of order)

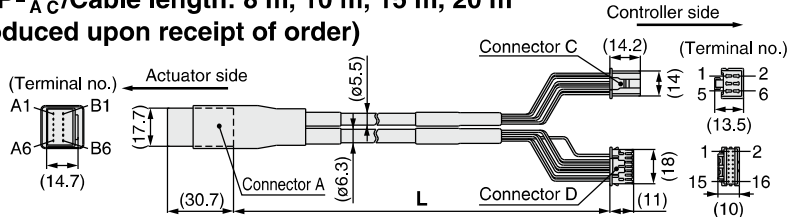

Signal	Connector A terminal no.	Cable color	Connector C terminal no.
A	B-1	Brown	2
A	A-1	Red	1
B	B-2	Orange	6
B	A-2	Yellow	5
COM-A/COM	B-3	Green	3
COM-B/-	A-3	Blue	4
Shield			
Vcc	B-4	Brown	12
GND	A-4	Black	13
A	B-5	Red	7
A	A-5	Black	6
B	B-6	Orange	9
B	A-6	Black	8
		-	3

[Robotic cable, standard cable with lock and sensor for step motor (Servo/24 VDC)]

**LE-CP-1-B** - [ ]

Cable length (L) [m]

1	1.5
3	3
5	5
8	8*
A	10*
B	15*
C	20*

\* Produced upon receipt of order (Robotic cable only)

With lock and sensor

Cable type

Nil	Robotic cable (Flexible cable)
S	Standard cable

### Weight

Product no.	Weight [g]	Note
LE-CP-1-B-S	240	Standard cable
LE-CP-3-B-S	380	
LE-CP-5-B-S	630	
LE-CP-1-B	190	Robotic cable
LE-CP-3-B	360	
LE-CP-5-B	590	
LE-CP-8-B	1060	
LE-CP-A-B	1320	
LE-CP-B-B	1920	
LE-CP-C-B	2620	

**LE-CP-3/5** / Cable length: 1.5 m, 3 m, 5 m

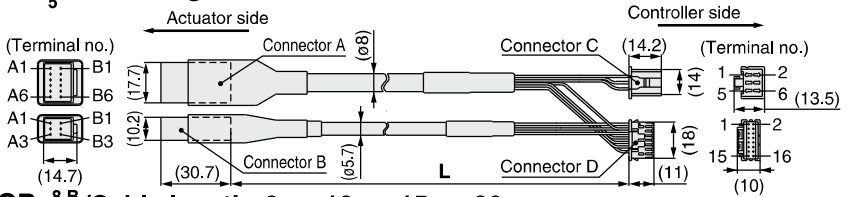

**LE-CP-8 A C** / Cable length: 8 m, 10 m, 15 m, 20 m  
(\* Produced upon receipt of order)

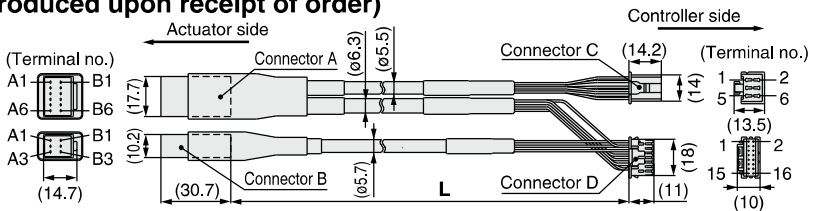

Signal	Connector A terminal no.	Cable color	Connector C terminal no.
A	B-1	Brown	2
A	A-1	Red	1
B	B-2	Orange	6
B	A-2	Yellow	5
COM-A/COM	B-3	Green	3
COM-B/-	A-3	Blue	4
Shield			
Vcc	B-4	Brown	12
GND	A-4	Black	13
A	B-5	Red	7
A	A-5	Black	6
B	B-6	Orange	9
B	A-6	Black	8
		-	3

Signal	Connector B terminal no.	Cable color	Connector D terminal no.
Lock (+)	B-1	Red	4
Lock (-)	A-1	Black	5
Sensor (+)	B-3	Brown	1
Sensor (-)	A-3	Blue	2

## Options

### ■ Controller setting kit JXC-W2

#### [Contents]

- ① Communication cable
- ② USB cable
- ③ Controller setting software
- \* A conversion cable (P5062-5) is not required.
- \* The supported OS are Windows®7 and Windows®8.1.  
For Windows®10, use the LEC-W2A-C (pages 569, 597, and 603-2) and the P5062-5 conversion cable in combination.

#### JXC-W2-□

#### ● Contents

Nil	A kit includes: Communication cable, USB cable, Controller setting software
C	Communication cable
U	USB cable
S	Controller setting software (CD-ROM)

#### ① Communication cable JXC-W2-C

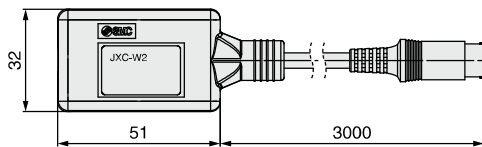

\* It can be connected to the controller directly.

#### ② USB cable JXC-W2-U

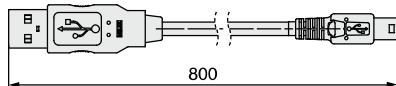

#### ③ Controller setting software (CD-ROM) JXC-W2-S

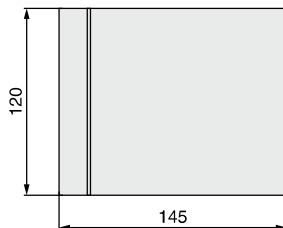

### ■ DIN rail mounting adapter LEC-3-D0

\* With 2 mounting screws

This should be used when a DIN rail mounting adapter is mounted onto a screw mounting type controller afterwards.

### ■ DIN rail AXT100-DR-□

\* For □, enter a number from the No. line in the table on page 603-8. Refer to the dimension drawings on pages 603-8 and 603-9 for the mounting dimensions.

### ■ Power supply plug JXC-CPW

\* The power supply plug is an accessory.

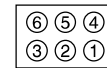
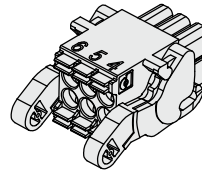

- ① C24V
- ② M24V
- ③ EMG
- ④ 0V
- ⑤ N.C.
- ⑥ LK RLS

#### Power supply plug

Terminal name	Function	Details
0V	Common supply (-)	M24V terminal/C24V terminal/EMG terminal/LK RLS terminal are common (-).
M24V	Motor power supply (+)	Motor power supply (+) of the controller
C24V	Control power supply (+)	Control power supply (+) of the controller
EMG	Stop (+)	Connection terminal of the external stop circuit
LK RLS	Lock release (+)	Connection terminal of the lock release switch

### ■ Communication plug connector

#### For DeviceNet™

#### Straight type JXC-CD-S

#### T-branch type JXC-CD-T

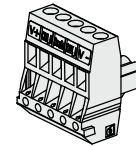
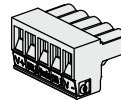

#### Communication plug connector for DeviceNet™

Terminal name	Details
V+	Power supply (+) for DeviceNet™
CAN_H	Communication wire (High)
Drain	Grounding wire/Shielded wire
CAN_L	Communication wire (Low)
V-	Power supply (-) for DeviceNet™

#### For IO-Link

#### Straight type JXC-CL-S

\* The communication plug connector for IO-Link is an accessory.

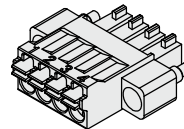

#### Communication plug connector for IO-Link

Terminal no.	Terminal name	Details
1	L+	+24 V
2	NC	N/A
3	L-	0 V
4	C/Q	IO-Link signal

### ■ Conversion cable P5062-5 (Cable length: 300 mm)

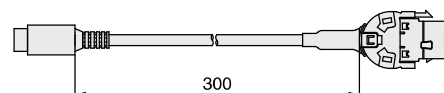

\* To connect the teaching box (LEC-T1-3□G□) or controller setting kit (LEC-W2) to the controller, a conversion cable is required.



# Precautions Related to Differences in Controller Versions

## JXCE1/91/P1/D1/L1 Series

As the controller version of the JXC series differs, the internal parameters are not compatible.

- If using the JXC□1□-BC, please use the latest version of the JXC-BCW (parameter writing tool).
- There are currently 3 versions available: version 1 products (V1.□ or S1.□), version 2 products (V2.□ or S2.□), and version 3 products (V3.□ or S3.□). Keep in mind that in order to write a backup file (.bkw) to another controller with the JXC-BCW, it needs to be the same version as the controller that created the file. (For example, a backup file created by a version 1 product can only be written to another version 1 product, and so on.)

## Identifying Version Symbols

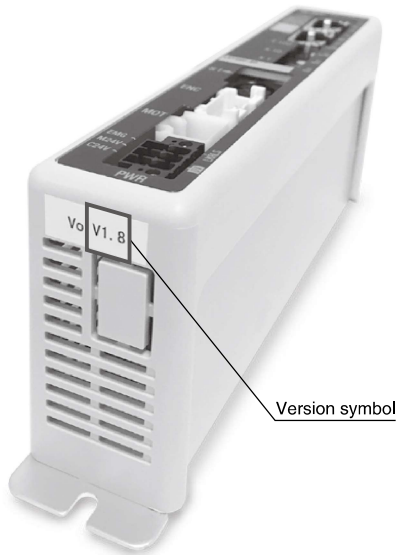

### JXC□1 Series Version V3.□ or S3.□ Products

XR V3.0

Applicable models  
JXC91□ Series

XR S3.0 T1.0

Applicable models  
JXCD1□ Series  
JXCE1□ Series  
JXCP1□ Series  
JXCL1□ Series

### JXC□1 Series Version V2.□ or S2.□ Products

WP V2.1

Applicable models  
JXC91□ Series

WP S2.2 T1.1

Applicable models  
JXCD1□ Series  
JXCE1□ Series  
JXCP1□ Series  
JXCL1□ Series

### JXC□1 Series Version V1.□ or S1.□ Products

XR V1.0

Applicable models  
JXC91□ Series

XR S1.0 T1.0

Applicable models  
JXCD1□ Series  
JXCE1□ Series  
JXCP1□ Series  
JXCL1□ Series

## JXC□1-XZ23 Series

Due to the difference in controller versions, the internal parameters of the 55°C specification (JXC□1-XZ23) and the 40°C specification (standard model, JXC□1) are not compatible.

- If using the JXC□1□-BC-XZ23, please use the latest version of the JXC-BCW (parameter writing tool).

## How to Order



LEC-T1-3 J G

Teaching box

Enable switch

Cable length [m]

3	3
---	---

Nil	None
S	Equipped with enable switch

\* Interlock switch for jog and test function

Initial language

J	Japanese
E	English

Stop switch

G	Equipped with stop switch
---	---------------------------

\* The displayed language can be changed to English or Japanese.

## Specifications

### Standard functions

- Chinese character display
- Stop switch is provided.

### Option

- Enable switch is provided.

Item	Description
Switch	Stop switch, Enable switch (Option)
Cable length [m]	3
Enclosure	IP64 (Except connector)
Operating temperature range [°C]	5 to 50
Operating humidity range [%RH]	90 or less (No condensation)
Weight [g]	350 (Except cable)

### [CE-compliant products]

The EMC compliance of the teaching box was tested with the LECP6 series step motor controller (servo/24 VDC) and an applicable actuator.

### [UL-compliant products]

When conformity to UL is required, the electric actuator and controller should be used with a UL1310 Class 2 power supply.

## Easy Mode

Function	Details
Step data	• Setting of step data
Jog	• Jog operation • Return to origin
Test	• 1 step operation • Return to origin
Monitor	• Display of axis and step data no. • Display of two items selected from Position, Speed, Force.
ALM	• Active alarm display • Alarm reset
TB setting	• Reconnection of axis (Ver. 1.**) • Displayed language setting (Ver. 2.**) • Setting of easy/normal mode • Setting step data and selection of items from easy mode monitor

### Menu Operations Flowchart

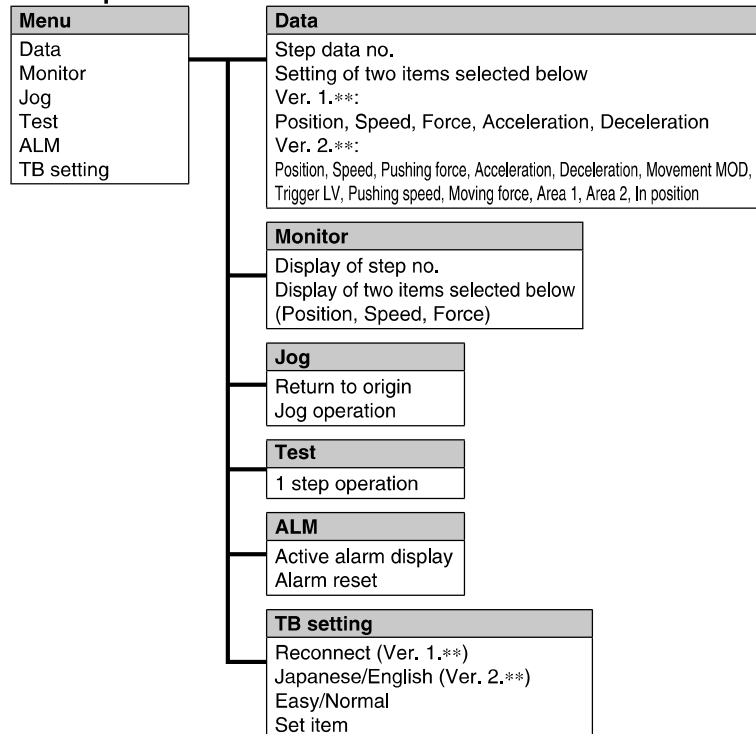

## Normal Mode

Function	Details
Step data	• Step data setting
Parameter	• Parameters setting
Test	<ul style="list-style-type: none"> <li>• Jog operation/Constant rate movement</li> <li>• Return to origin</li> <li>• Test drive (Specify a maximum of 5 step data and operate.)</li> <li>• Forced output (Forced signal output, Forced terminal output)</li> </ul>
Monitor	<ul style="list-style-type: none"> <li>• Drive monitor</li> <li>• Output signal monitor</li> <li>• Input signal monitor</li> <li>• Output terminal monitor</li> <li>• Input terminal monitor</li> </ul>
ALM	<ul style="list-style-type: none"> <li>• Active alarm display (Alarm reset)</li> <li>• Alarm log record display</li> </ul>
File	<ul style="list-style-type: none"> <li>• Data saving Save the step data and parameters of the controller which is being used for communication (it is possible to save four files, with one set of step data and parameters defined as one file).</li> <li>• Load to controller Loads the data which is saved in the teaching box to the controller which is being used for communication.</li> <li>• Delete the saved data.</li> <li>• File protection (Ver. 2.**)</li> </ul>
TB setting	<ul style="list-style-type: none"> <li>• Display setting (Easy/Normal mode)</li> <li>• Language setting (Japanese/English)</li> <li>• Backlight setting</li> <li>• LCD contrast setting</li> <li>• Beep sound setting</li> <li>• Max. connection axis</li> <li>• Distance unit (mm/inch)</li> </ul>
Reconnect	• Reconnection of axis

## Menu Operations Flowchart

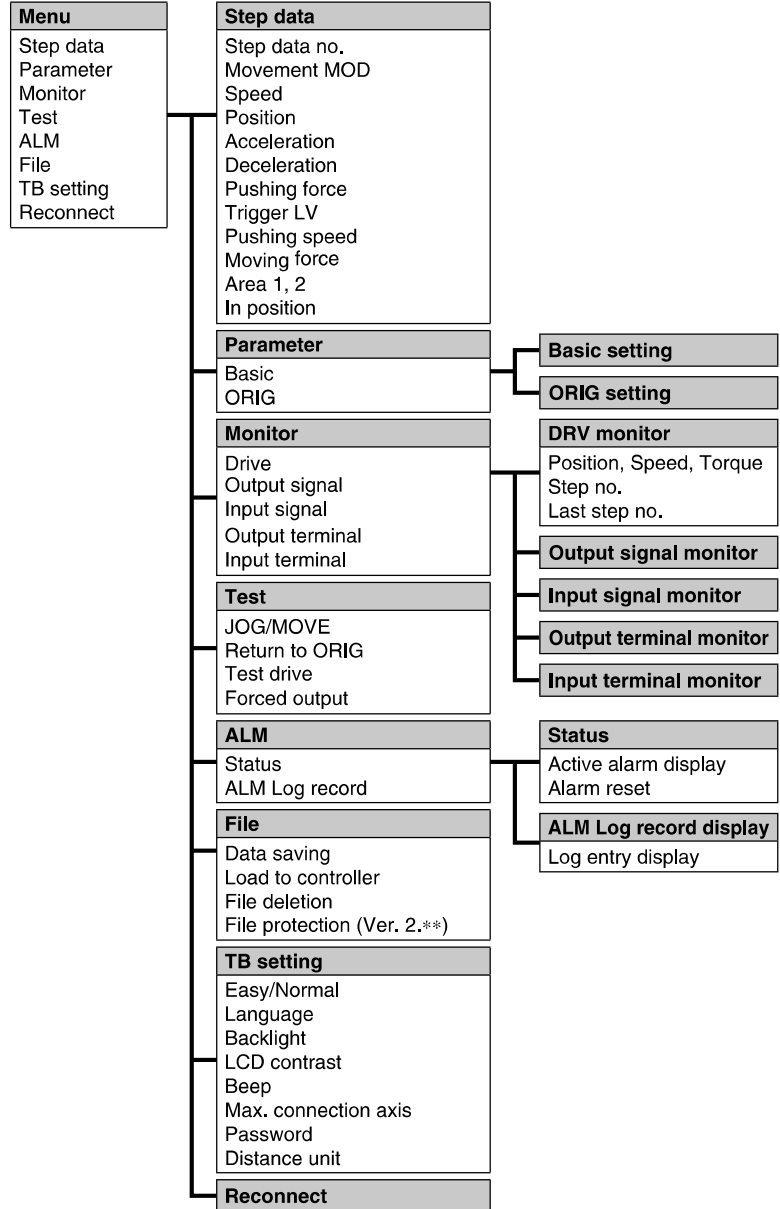

## Dimensions

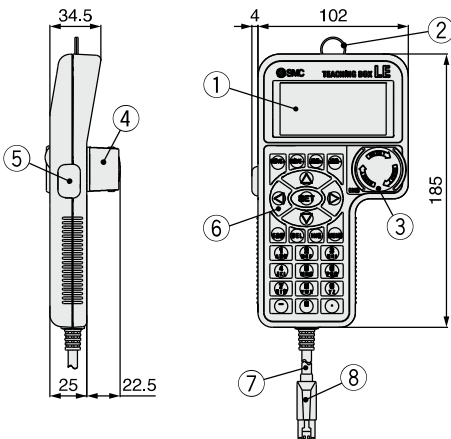

No.	Description	Function
1	<b>LCD</b>	A screen of liquid crystal display (with backlight)
2	<b>Ring</b>	A ring for hanging the teaching box
3	<b>Stop switch</b>	When switch is pushed in, the switch locks and stops. The lock is released when it is turned to the right.
4	<b>Stop switch guard</b>	A guard for the stop switch
5	<b>Enable switch (Option)</b>	Prevents unintentional operation (unexpected operation) of the jog test function. Other functions such as data change are not covered.
6	<b>Key switch</b>	Switch for each input
7	<b>Cable</b>	Length: 3 meters
8	<b>Connector</b>	A connector connected to CN4 of the controller

# 3-Axis Step Motor Controller (EtherNet/IP™ Type)

## JXC92 Series



### How to Order

#### ■ EtherNet/IP™ Type (JXC92)

#### Controller



**JXC 9 2 7**

EtherNet/IP™ type

3-axis type

Mounting

Symbol	Mounting
7	Screw mounting
8	DIN rail

#### Applicable Actuators

Applicable actuators	
Electric Actuator/Rod LEY Series	p. 215
Electric Actuator/Guide Rod LEYG Series	p. 215
Electric Actuator/Slider LEF Series	p. 31
Electric Slide Table LES/LESH Series	p. 307
Electric Rotary Table LER Series	p. 399
Electric Actuator/Miniature LEPY/LEPS Series	p. 369
Electric Gripper (2-Finger Type, 3-Finger Type) LEH Series	p. 425

\* Order the actuator separately, including the actuator cable.  
(Example: LEFS16B-100B-S1)

\* For the "Speed-Work Load" graph of the actuator, refer to the LECPA section on the model selection page of the electric actuators **Web Catalog**.

### Specifications

For the setting of functions and operation methods, refer to the [operation manual](#) on the SMC website. (Documents/Download --> Instruction Manuals)

#### EtherNet/IP™ Type (JXC92)

Item		Specifications
Number of axes		Max. 3 axes
Compatible motor		Step motor (Servo/24 VDC)
Compatible encoder		Incremental A/B phase (Encoder resolution: 800 pulse/rotation)
Power supply *1		Control power supply Power voltage: 24 VDC ±10% Max. current consumption: 500 mA Motor power supply Power voltage: 24 VDC ±10% Max. current consumption: Based on the connected actuator *2
Communication	Protocol	EtherNet/IP™ *3
	Communication speed	10 Mbps/100 Mbps (automatic negotiation)
	Communication method	Full duplex/Half duplex (automatic negotiation)
	Configuration file	EDS file
	Occupied area	Input 16 bytes/Output 16 bytes
	IP address setting range	Manual setting by switches: From 192.168.1.1 to 254, Via DHCP server: Arbitrary address
	Vendor ID	7 h (SMC Corporation)
Product type	2 Bh (Generic Device)	
Product code	DEh	
Serial communication		USB2.0 (Full Speed 12 Mbps)
Memory		Flash-ROM
LED indicator		PWR, RUN, USB, ALM, NS, MS, L/A, 100
Lock control		Forced-lock release terminal *4
Cable length		Actuator cable: 20 m or less
Cooling system		Natural air cooling
Operating temperature range		0°C to 40°C (No freezing)
Operating humidity range		90% RH or less (No condensation)
Storage temperature range		-10°C to 60°C (No freezing)
Storage humidity range		90% RH or less (No condensation)
Insulation resistance		Between all external terminals and the case: 50 MΩ (500 VDC)
Weight		600 g (Screw mounting), 650 g (DIN rail mounting)

\*1 Do not use a power supply with inrush current protection for the motor drive power supply.

\*2 Power consumption depends on the actuator connected. Refer to the actuator specifications for further details.

\*3 EtherNet/IP™ is a trademark of ODVA.

\*4 Applicable to non-magnetizing locks

## Dimensions

### EtherNet/IP™ Type JXC92

#### Screw mounting

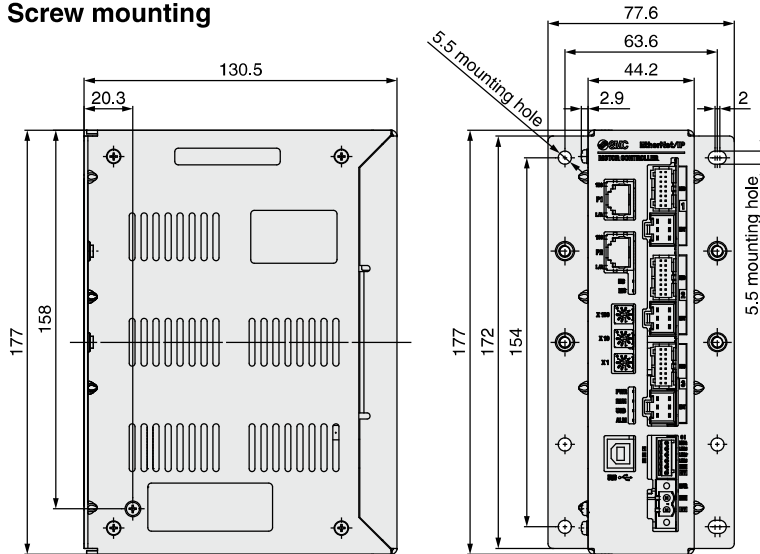

#### DIN rail mounting

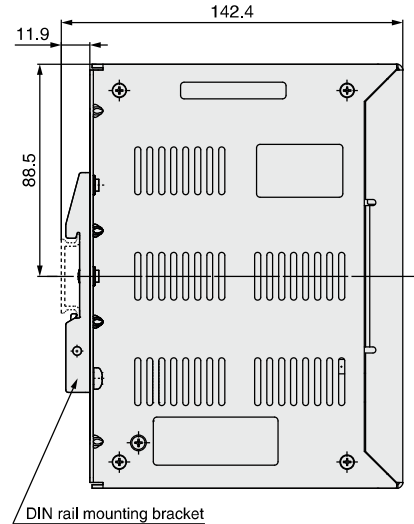

## Controller Details

### EtherNet/IP™ Type JXC92

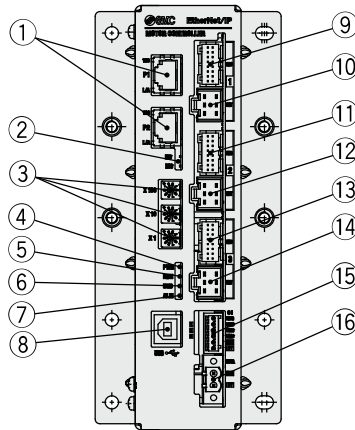

No.	Name	Description	Details
①	<b>P1, P2</b>	EtherNet/IP™ communication connector	Connect Ethernet cable.
②	<b>NS, MS</b>	Communication status LED	Displays the status of the EtherNet/IP™ communication
③	<b>X100</b> <b>X10</b> <b>X1</b>	IP address setting switches	Switch to set the 4th byte of the IP address by X1, X10 and X100.
④	<b>PWR</b>	Power supply LED (Green)	Power supply ON: Green turns on Power supply OFF: Green turns off
⑤	<b>RUN</b>	Operation LED (Green)	Running in EtherNet/IP™: Green turns on Running via USB communication: Green flashes Stopped: Green turns off
⑥	<b>USB</b>	USB connection LED (Green)	USB connected: Green turns on USB not connected: Green turns off
⑦	<b>ALM</b>	Alarm LED (Red)	With alarm: Red turns on Without alarm: Red turns off
⑧	<b>USB</b>	Serial communication connector	Connect to a PC via the USB cable.
⑨	<b>ENC ①</b>	Encoder connector (16 pins)	Axis 1: Connect the actuator cable.
⑩	<b>MOT ①</b>	Motor power connector (6 pins)	
⑪	<b>ENC ②</b>	Encoder connector (16 pins)	Axis 2: Connect the actuator cable.
⑫	<b>MOT ②</b>	Motor power connector (6 pins)	
⑬	<b>ENC ③</b>	Encoder connector (16 pins)	Axis 3: Connect the actuator cable.
⑭	<b>MOT ③</b>	Motor power connector (6 pins)	
⑮	<b>CI</b>	Control power supply connector *1	Control power supply (+), All axes stop (+), Axis 1 lock release (+), Axis 2 lock release (+), Axis 3 lock release (+), Common (-)
⑯	<b>M PWR</b>	Motor power supply connector *1	Motor power supply (+), Motor power supply (-)

\*1 Connectors are included. (Refer to page 606-7.)

# 4-Axis Step Motor Controller (Parallel I/O/EtherNet/IP™ Type)

## JXC73/83/93 Series



### How to Order

#### ■ Parallel I/O (JXC73/83)

#### Controller



JXC **7** **3** **2**

I/O type

Symbol	I/O type
7	NPN
8	PNP

I/O cable, mounting

Symbol	I/O cable	Mounting
1	1.5 m	Screw mounting
2	1.5 m	DIN rail
3	3 m	Screw mounting
4	3 m	DIN rail
5	5 m	Screw mounting
6	5 m	DIN rail
7	None	Screw mounting
8	None	DIN rail

4-axis type

\* Two I/O cables are included.

#### ■ EtherNet/IP™ Type (JXC93)

#### Controller



JXC **9** **3** **7**

EtherNet/IP™ type

Mounting

Symbol	Mounting
7	Screw mounting
8	DIN rail

4-axis type

#### Applicable Actuators

Applicable actuators	
Electric Actuator/Rod LEY Series	p. 215
Electric Actuator/Guide Rod LEYG Series	p. 215
Electric Actuator/Slider LEF Series	p. 31
Electric Slide Table LES/LESH Series	p. 307
Electric Rotary Table LER Series *1	p. 399
Electric Actuator/Miniature LEPY/LEPS Series	p. 369
Electric Gripper (2-Finger Type, 3-Finger Type) LEH Series	p. 425

\*1 Except the continuous rotation (360°) specification.

\* Order the actuator separately, including the actuator cable.  
(Example: LEFS16B-100B-S1)

\* For the "Speed-Work Load" graph of the actuator, refer to the LECPA section on the model selection page.

## Specifications

For the setting of functions and operation methods, refer to the [operation manual](#) on the SMC website. (Documents/Download --> Instruction Manuals)

### Parallel I/O (JXC73/83)

Item	Specifications
<b>Number of axes</b>	Max. 4 axes
<b>Compatible motor</b>	Step motor (Servo/24 VDC)
<b>Compatible encoder</b>	Incremental A/B phase (Encoder resolution: 800 pulse/rotation)
<b>Power supply</b> *1	Main control power supply Power voltage: 24 VDC ±10% Max. current consumption: 300 mA Motor power supply, Motor control power supply (Common) Power voltage: 24 VDC ±10% Max. current consumption: Based on the connected actuator *2
<b>Parallel input</b>	16 inputs (Photo-coupler isolation)
<b>Parallel output</b>	32 outputs (Photo-coupler isolation)
<b>Serial communication</b>	USB2.0 (Full Speed 12 Mbps)
<b>Memory</b>	Flash-ROM/EEPROM
<b>LED indicator</b>	PWR, RUN, USB, ALM
<b>Lock control</b>	Forced-lock release terminal *3
<b>Cable length</b>	I/O cable: 5 m or less, Actuator cable: 20 m or less
<b>Cooling system</b>	Natural air cooling
<b>Operating temperature range</b>	0°C to 40°C (No freezing)
<b>Operating humidity range</b>	90% RH or less (No condensation)
<b>Storage temperature range</b>	-10°C to 60°C (No freezing)
<b>Storage humidity range</b>	90% RH or less (No condensation)
<b>Insulation resistance</b>	Between all external terminals and the case: 50 MΩ (500 VDC)
<b>Weight</b>	1050 g (Screw mounting), 1100 g (DIN rail mounting)

\*1 Do not use a power supply with inrush current protection for the motor drive power and motor control power supply.

\*2 Power consumption depends on the actuator connected. Refer to the actuator specifications for further details.

\*3 Applicable to non-magnetizing locks

For the setting of functions and operation methods, refer to the [operation manual](#) on the SMC website. (Documents/Download --> Instruction Manuals)

### EtherNet/IP™ Type (JXC93)

Item	Specifications	
<b>Number of axes</b>	Max. 4 axes	
<b>Compatible motor</b>	Step motor (Servo/24 VDC)	
<b>Compatible encoder</b>	Incremental A/B phase (Encoder resolution: 800 pulse/rotation)	
<b>Power supply</b> *1	Main control power supply Power voltage: 24 VDC ±10% Max. current consumption: 350 mA Motor power supply, Motor control power supply (Common) Power voltage: 24 VDC ±10% Max. current consumption: Based on the connected actuator *2	
<b>Communication</b>	<b>Protocol</b>	EtherNet/IP™ *4
	<b>Communication speed</b>	10 Mbps/100 Mbps (automatic negotiation)
	<b>Communication method</b>	Full duplex/Half duplex (automatic negotiation)
	<b>Configuration file</b>	EDS file
	<b>Occupied area</b>	Input 16 bytes/Output 16 bytes
	<b>IP address setting range</b>	Manual setting by switches: From 192.168.1.1 to 254, Via DHCP server: Arbitrary address
	<b>Vendor ID</b>	7 h (SMC Corporation)
	<b>Product type</b>	2 Bh (Generic Device)
	<b>Product code</b>	DCh
<b>Serial communication</b>	USB2.0 (Full Speed 12 Mbps)	
<b>Memory</b>	Flash-ROM/EEPROM	
<b>LED indicator</b>	PWR, RUN, USB, ALM, NS, MS, L/A, 100	
<b>Lock control</b>	Forced-lock release terminal *3	
<b>Cable length</b>	Actuator cable: 20 m or less	
<b>Cooling system</b>	Natural air cooling	
<b>Operating temperature range</b>	0°C to 40°C (No freezing)	
<b>Operating humidity range</b>	90% RH or less (No condensation)	
<b>Storage temperature range</b>	-10°C to 60°C (No freezing)	
<b>Storage humidity range</b>	90% RH or less (No condensation)	
<b>Insulation resistance</b>	Between all external terminals and the case: 50 MΩ (500 VDC)	
<b>Weight</b>	1050 g (Screw mounting), 1100 g (DIN rail mounting)	

\*1 Do not use a power supply with inrush current protection for the motor drive power and motor control power supply.

\*2 Power consumption depends on the actuator connected. Refer to the actuator specifications for further details.

\*3 Applicable to non-magnetizing locks

\*4 EtherNet/IP™ is a trademark of ODVA.

# JXC73/83/93 Series

## Dimensions

### Parallel I/O JXC73/83

#### Screw mounting

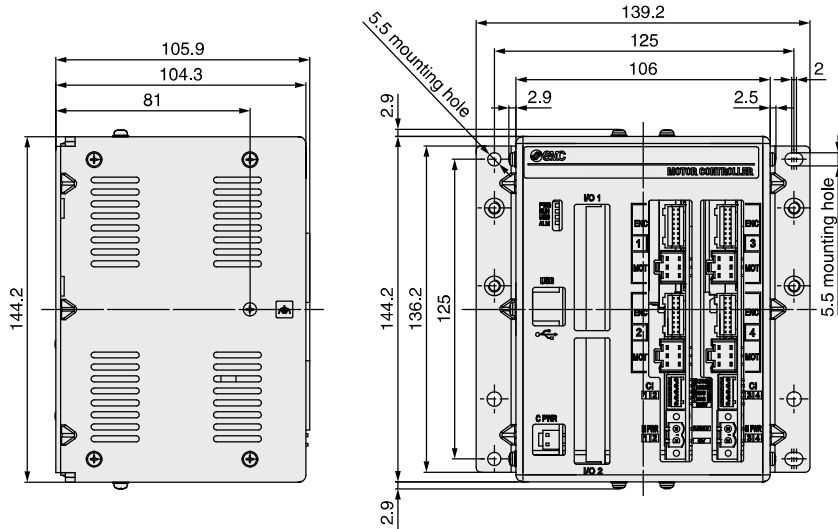

#### DIN rail mounting

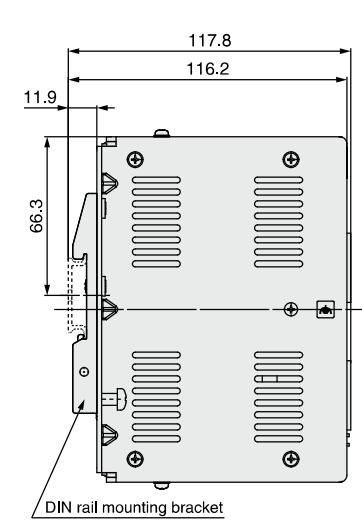

### EtherNet/IP™ Type JXC93

#### Screw mounting

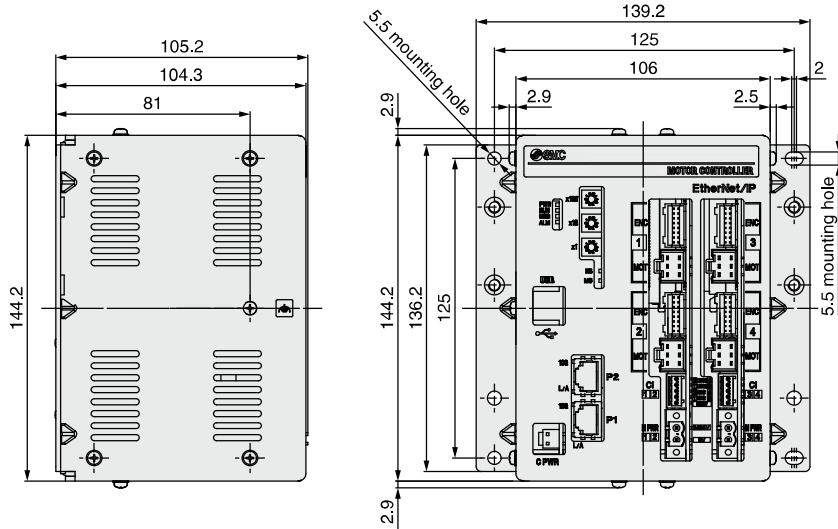

#### DIN rail mounting

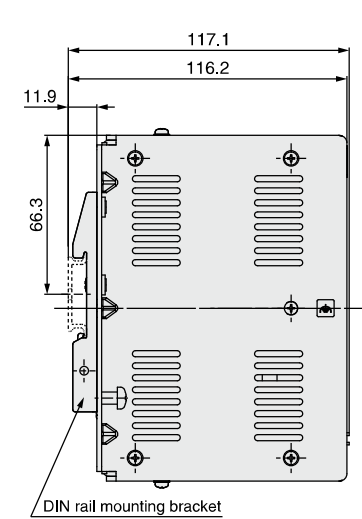

## Controller Details

### Parallel I/O JXC73/83

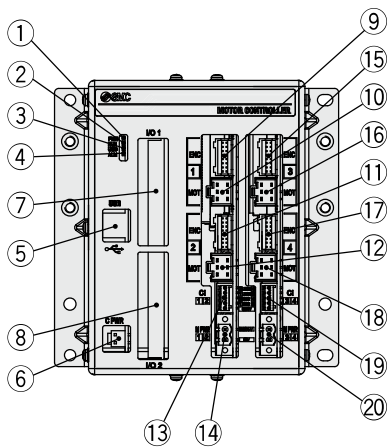

No.	Name	Description	Details
①	<b>PWR</b>	Power supply LED (Green)	Power supply ON: Green turns on Power supply OFF: Green turns off
②	<b>RUN</b>	Operation LED (Green)	Running in parallel I/O: Green turns on Running via USB communication: Green flashes Stopped: Green turns off
③	<b>USB</b>	USB connection LED (Green)	USB connected: Green turns on USB not connected: Green turns off
④	<b>ALM</b>	Alarm LED (Red)	With alarm: Red turns on Without alarm: Red turns off
⑤	<b>USB</b>	Serial communication	Connect to a PC via the USB cable.
⑥	<b>C PWR</b>	Main control power supply connector (2 pins) *1	Main control power supply (+) (-)
⑦	<b>I/O 1</b>	Parallel I/O connector (40 pins)	Connect to a PLC via the I/O cable.
⑧	<b>I/O 2</b>	Parallel I/O connector (40 pins)	Connect to a PLC via the I/O cable.
⑨	<b>ENC 1</b>	Encoder connector (16 pins)	Axis 1: Connect the actuator cable.
⑩	<b>MOT 1</b>	Motor power connector (6 pins)	
⑪	<b>ENC 2</b>	Encoder connector (16 pins)	Axis 2: Connect the actuator cable.
⑫	<b>MOT 2</b>	Motor power connector (6 pins)	
⑬	<b>CI 1 2</b>	Motor control power supply connector *1	Motor control power supply (+), Axis 1 stop (+), Axis 1 lock release (+), Axis 2 stop (+), Axis 2 lock release (+)
⑭	<b>M PWR 1 2</b>	Motor power supply connector *1	For Axis 1, 2. Motor power supply (+), Common (-)
⑮	<b>ENC 3</b>	Encoder connector (16 pins)	Axis 3: Connect the actuator cable.
⑯	<b>MOT 3</b>	Motor power connector (6 pins)	
⑰	<b>ENC 4</b>	Encoder connector (16 pins)	Axis 4: Connect the actuator cable.
⑱	<b>MOT 4</b>	Motor power connector (6 pins)	
⑲	<b>CI 3 4</b>	Motor control power supply connector *1	Motor control power supply (+), Axis 3 stop (+), Axis 3 lock release (+), Axis 4 stop (+), Axis 4 lock release (+)
⑳	<b>M PWR 3 4</b>	Motor power supply connector *1	For Axis 3, 4. Motor power supply (+), Common (-)

\*1 Connectors are included. (Refer to page 606-7.)

### EtherNet/IP™ Type JXC93

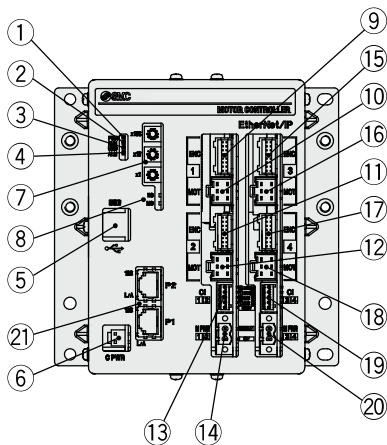

No.	Name	Description	Details
①	<b>PWR</b>	Power supply LED (Green)	Power supply ON: Green turns on Power supply OFF: Green turns off
②	<b>RUN</b>	Operation LED (Green)	Running in EtherNet/IP™: Green turns on Running via USB communication: Green flashes Stopped: Green turns off
③	<b>USB</b>	USB connection LED (Green)	USB connected: Green turns on USB not connected: Green turns off
④	<b>ALM</b>	Alarm LED (Red)	With alarm: Red turns on Without alarm: Red turns off
⑤	<b>USB</b>	Serial communication	Connect to a PC via the USB cable.
⑥	<b>C PWR</b>	Main control power supply connector (2 pins) *1	Main control power supply (+) (-)
⑦	<b>x100 x10 x1</b>	IP address setting switches	Switch to set the 4th byte of the IP address by X1, X10 and X100.
⑧	<b>MS, NS</b>	Communication status LED	Displays the status of the EtherNet/IP™ communication
⑨	<b>ENC 1</b>	Encoder connector (16 pins)	Axis 1: Connect the actuator cable.
⑩	<b>MOT 1</b>	Motor power connector (6 pins)	
⑪	<b>ENC 2</b>	Encoder connector (16 pins)	Axis 2: Connect the actuator cable.
⑫	<b>MOT 2</b>	Motor power connector (6 pins)	
⑬	<b>CI 1 2</b>	Motor control power supply connector *1	Motor control power supply (+), Axis 1 stop (+), Axis 1 lock release (+), Axis 2 stop (+), Axis 2 lock release (+)
⑭	<b>M PWR 1 2</b>	Motor power supply connector *1	For Axis 1, 2. Motor power supply (+), Common (-)
⑮	<b>ENC 3</b>	Encoder connector (16 pins)	Axis 3: Connect the actuator cable.
⑯	<b>MOT 3</b>	Motor power connector (6 pins)	
⑰	<b>ENC 4</b>	Encoder connector (16 pins)	Axis 4: Connect the actuator cable.
⑱	<b>MOT 4</b>	Motor power connector (6 pins)	
⑲	<b>CI 3 4</b>	Motor control power supply connector *1	Motor control power supply (+), Axis 3 stop (+), Axis 3 lock release (+), Axis 4 stop (+), Axis 4 lock release (+)
⑳	<b>M PWR 3 4</b>	Motor power supply connector *1	For Axis 3, 4. Motor power supply (+), Common (-)
㉑	<b>P1, P2</b>	EtherNet/IP™ communication connector	Connect Ethernet cable.

\*1 Connectors are included. (Refer to page 606-7.)

# JXC73/83/92/93 Series

## Wiring Example 1

### Cable with Main Control Power Supply Connector (For 4 Axes)\*1: C PWR 1 pc.

For 4 Axes  
JXC73/83/93

Terminal name	Function	Details
+24V	Main control power supply (+)	Power supply (+) supplied to the main control
24-0V	Main control power supply (-)	Power supply (-) supplied to the main control

\*1 Part no.: JXC-C1 (Cable length: 1.5 m)

### Cable with main control power supply connector

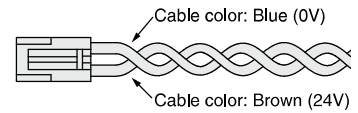

### Motor Power Supply Connector (For 3/4 Axes)\*2: M PWR 2 pcs.\*3

For 3 Axes  
JXC92

For 4 Axes  
JXC73/83/93

Terminal name	Function	Details	Note
0V	Motor power supply (-)	Power supply (-) supplied to the motor power The M 24V terminal, C 24V terminal, EMG terminal, and LKRLS terminal are common (-).	For 3 axes JXC92 For 4 axes JXC73/83/93
M 24V	Motor power supply (+)	Power supply (+) supplied to the motor power	

\*2 Manufactured by PHOENIX CONTACT (Part no.: MSTB2, 5/2-STF-5, 08)

\*3 1 pc. for 3 axes (JXC92)

### Motor power supply connector

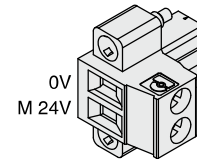

### Motor Control Power Supply Connector (For 4 Axes)\*4: CI 2 pcs.

For 4 Axes  
JXC73/83/93

Terminal name	Function	Details
C 24V	Motor control power supply (+)	Power supply (+) supplied to the motor control
EMG1/EMG3	Stop (+)	Axis 1/Axis 3: Input (+) for releasing the stop
EMG2/EMG4	Stop (+)	Axis 2/Axis 4: Input (+) for releasing the stop
LKRLS1/LKRLS3	Lock release (+)	Axis 1/Axis 3: Input (+) for releasing the lock
LKRLS2/LKRLS4	Lock release (+)	Axis 2/Axis 4: Input (+) for releasing the lock

\*4 Manufactured by PHOENIX CONTACT (Part no.: FK-MC0, 5/5-ST-2, 5)

### Motor control power supply connector

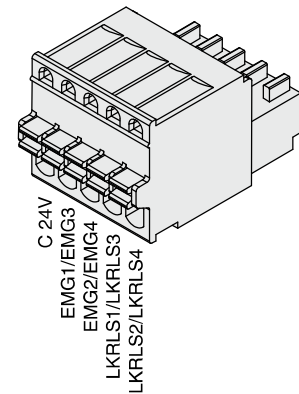

### Control Power Supply Connector (For 3 Axes)\*5: CI 1 pc.

For 3 Axes  
JXC92

Terminal name	Function	Details
0V	Control power supply (-)	The C 24V terminal, LKRLS terminal, and EMG terminal are common (-).
C 24V	Control power supply (+)	Power supply (+) supplied to the control
LKRLS3	Lock release (+)	Axis 3: Input (+) for releasing the lock
LKRLS2	Lock release (+)	Axis 2: Input (+) for releasing the lock
LKRLS1	Lock release (+)	Axis 1: Input (+) for releasing the lock
EMG	Stop (+)	All axes: Input (+) for releasing the stop

\*5 Manufactured by PHOENIX CONTACT (Part no.: FK-MC0, 5/6-ST-2, 5)

### Control power supply connector

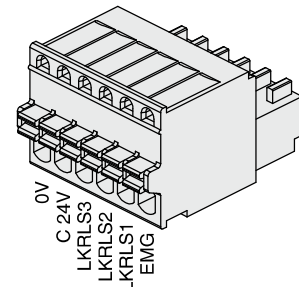

## Wiring Example 2

### Parallel I/O Connector

- \* When you connect a PLC to the I/O 1 or I/O 2 parallel I/O connector, use the I/O cable (JXC-C2-□).
- \* The wiring changes depending on the type of the parallel I/O (NPN or PNP).

### I/O 1 Wiring example

#### NPN JXC73

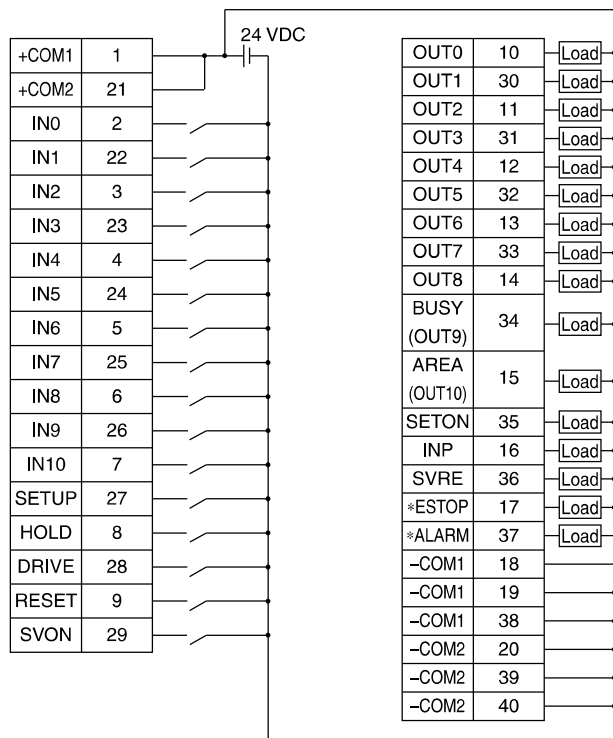

#### PNP JXC83

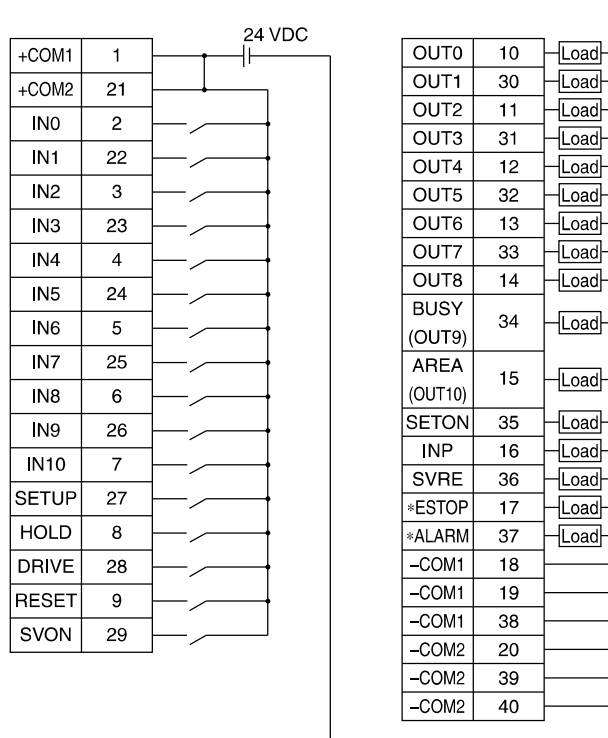

### I/O 1 Input Signal

Name	Details
+COM1 +COM2	Connects the power supply 24 V for input/output signal
IN0 to IN8	Step data specified Bit No. (Standard: When 512 points are used)
IN9 IN10	Step data specified extension Bit No. (Extension: When 2048 points are used)
SETUP	Instruction to return to origin
HOLD	Operation is temporarily stopped
DRIVE	Instruction to drive
RESET	Alarm reset and operation interruption
SVON	Servo ON instruction

### I/O 1 Output Signal

Name	Details
OUT0 to OUT8	Outputs the step data no. during operation
BUSY (OUT9)	Outputs when the operation of the actuator is in progress
AREA (OUT10)	Outputs when all actuators are within the area output range
SETON	Outputs when the return to origin of all actuators is completed
INP	Outputs when the positioning or pushing of all actuators is completed
SVRE	Outputs when servo is ON
*ESTOP *1	Not output when EMG stop is instructed
*ALARM *1	Not output when alarm is generated
-COM1 -COM2	Connects the power supply 0 V for input/output signal

\*1 Negative-logic circuit signal

# JXC73/83/92/93 Series

## Wiring Example 2

### Parallel I/O Connector

\* When you connect a PLC to the I/O 1 or I/O 2 parallel I/O connector, use the I/O cable (JXC-C2-□).  
 \* The wiring changes depending on the type of the parallel I/O (NPN or PNP).

### I/O 2 Wiring example

#### NPN JXC73

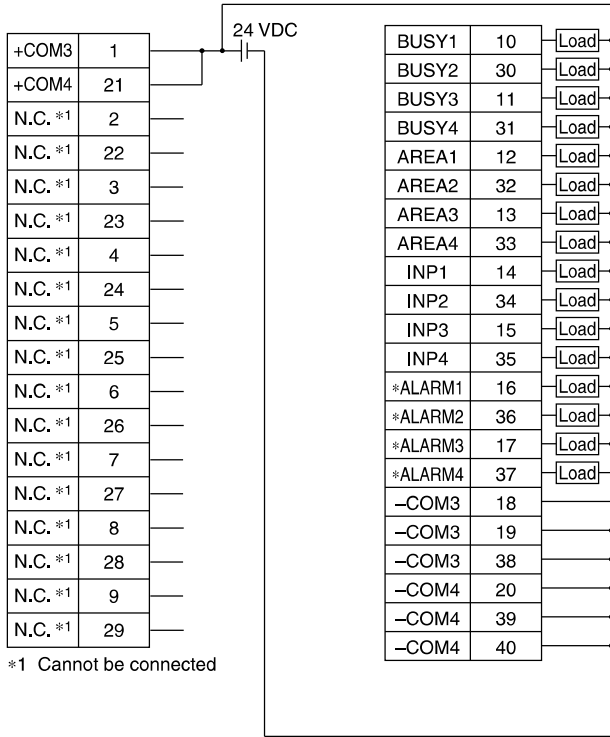

#### PNP JXC83

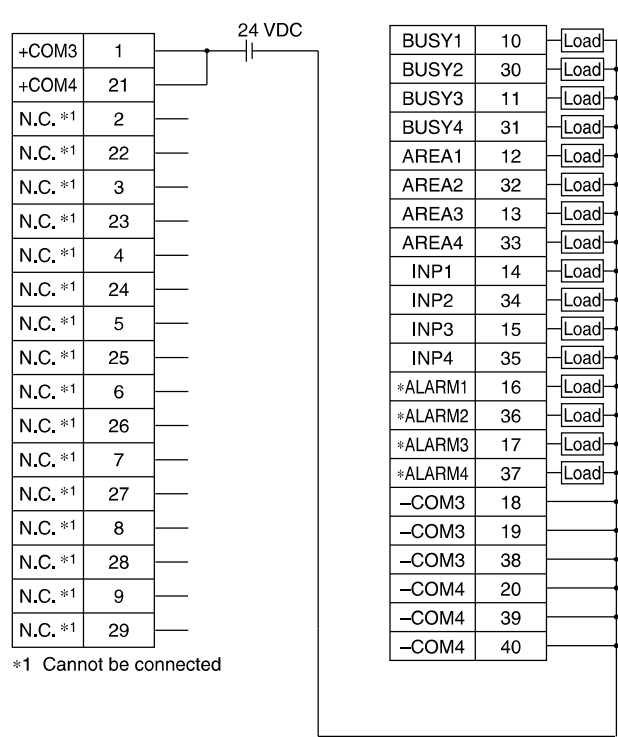

### I/O 2 Input Signal

Name	Details
+COM3 +COM4	Connects the power supply 24 V for input/output signal
N.C.	Cannot be connected

### I/O 2 Output Signal

Name	Details
BUSY1	Busy signal for axis 1
BUSY2	Busy signal for axis 2
BUSY3	Busy signal for axis 3
BUSY4	Busy signal for axis 4
AREA1	Area signal for axis 1
AREA2	Area signal for axis 2
AREA3	Area signal for axis 3
AREA4	Area signal for axis 4
INP1	Positioning or pushing completion signal for axis 1
INP2	Positioning or pushing completion signal for axis 2
INP3	Positioning or pushing completion signal for axis 3
INP4	Positioning or pushing completion signal for axis 4
*ALARM1 *2	Alarm signal for axis 1
*ALARM2 *2	Alarm signal for axis 2
*ALARM3 *2	Alarm signal for axis 3
*ALARM4 *2	Alarm signal for axis 4
-COM3 -COM4	Connects the power supply 0 V for input/output signal

\*2 Negative-logic circuit signal

## Options

**Cable with main control power supply connector** For 4 Axes  
JXC73/83/93

### JXC-C1

**Cable length: 1.5 m (Accessory)**

Number of cores	2
AWG size	AWG20

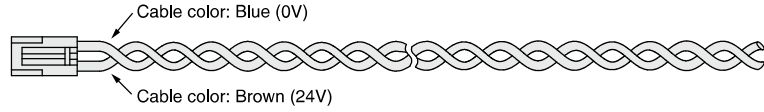

**I/O cable (1 pc.)**

### JXC-C2-□

For 4 Axes  
JXC73/83

**Cable length (L) [m]**

1	1.5
3	3
5	5

Number of cores	40
AWG size	AWG28

**Weight**

Product no.	Weight [g]
<b>JXC-C2-1</b>	160
<b>JXC-C2-3</b>	300
<b>JXC-C2-5</b>	480

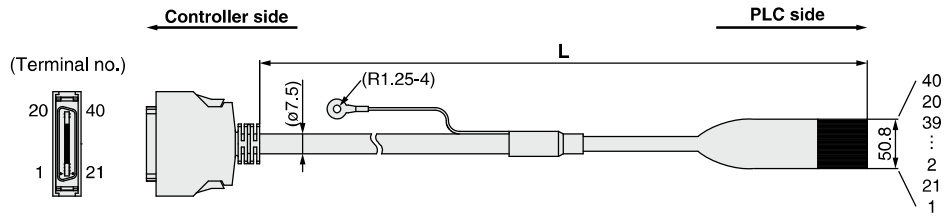

Pin no.	Wire color	Pin no.	Wire color	Pin no.	Wire color	Pin no.	Wire color
1	Orange (Black 1)	6	Orange (Black 2)	11	Orange (Black 3)	16	Orange (Black 4)
21	Orange (Red 1)	26	Orange (Red 2)	31	Orange (Red 3)	36	Orange (Red 4)
2	Gray (Black 1)	7	Gray (Black 2)	12	Gray (Black 3)	17	Gray (Black 4)
22	Gray (Red 1)	27	Gray (Red 2)	32	Gray (Red 3)	37	Gray (Red 4)
3	White (Black 1)	8	White (Black 2)	13	White (Black 3)	18	White (Black 4)
23	White (Red 1)	28	White (Red 2)	33	White (Red 3)	38	White (Red 4)
4	Yellow (Black 1)	9	Yellow (Black 2)	14	Yellow (Black 3)	19	Yellow (Black 4)
24	Yellow (Red 1)	29	Yellow (Red 2)	34	Yellow (Red 3)	39	Yellow (Red 4)
5	Pink (Black 1)	10	Pink (Black 2)	15	Pink (Black 3)	20	Pink (Black 4)
25	Pink (Red 1)	30	Pink (Red 2)	35	Pink (Red 3)	40	Pink (Red 4)

**DIN rail**

### AXT100-DR-□

For 3 Axes  
JXC92    For 4 Axes  
JXC73/83/93

\* For □, enter a number from the No. line in the table below. Refer to the dimension drawings on pages 606-2 and 606-5 for the mounting dimensions.

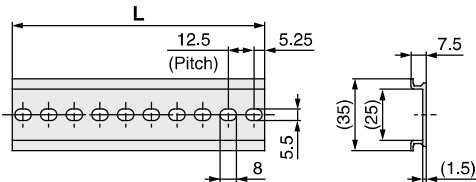

**L Dimension**

No.	1	2	3	4	5	6	7	8	9	10	11	12	13	14	15	16	17	18	19	20
L	23	35.5	48	60.5	73	85.5	98	110.5	123	135.5	148	160.5	173	185.5	198	210.5	223	235.5	248	260.5
No.	21	22	23	24	25	26	27	28	29	30	31	32	33	34	35	36	37	38	39	40
L	273	285.5	298	310.5	323	335.5	348	360.5	373	385.5	398	410.5	423	435.5	448	460.5	473	485.5	498	510.5

**DIN rail mounting bracket (with 6 mounting screws)** For 3 Axes    For 4 Axes  
JXC92    JXC73/83/93

### JXC-Z1

This should be used when the DIN rail mounting bracket is mounted onto a screw mounting type controller afterwards.

# JXC73/83/92/93 Series

## Options

### Controller setting kit

For 4 Axes  
JXC73/83/93

### JXC-W1

- Controller setting kit (Japanese and English are available.)

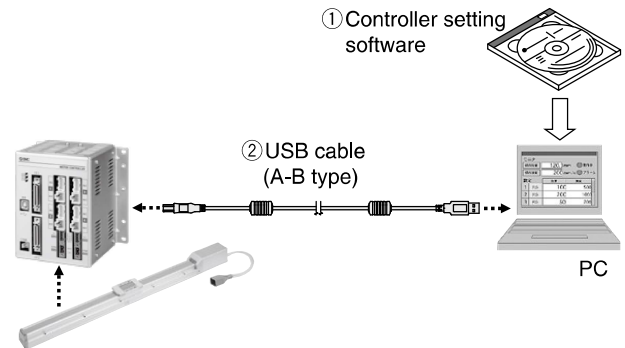

### Contents

- ① Controller setting software (CD-ROM)
- ② USB cable (Cable length: 3 m)

	Description	Model
①	Controller setting software	JXC-W1-1
②	USB cable	JXC-W1-2 (The same cable as the JXC-MA1-2)

\* Can be ordered separately

### Hardware Requirements

PC/AT compatible machine with Windows 7 or Windows 8.1 and USB1.1 or USB2.0 port

\* Windows® is a registered trademark of Microsoft Corporation in the United States.

### Controller setting kit

For 3 Axes  
JXC92

### JXC-MA1\*1

- Controller setting kit (Japanese and English are available.)

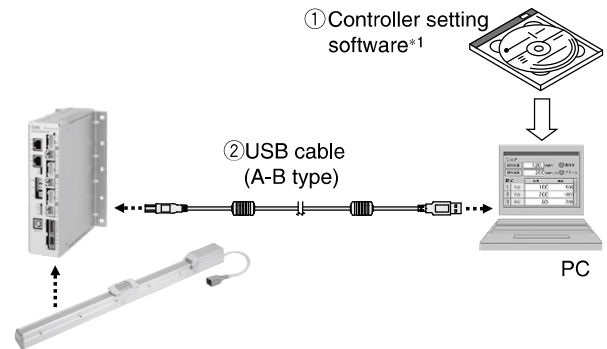

### Contents

- ① Controller setting software (CD-ROM)\*1
- ② USB cable (Cable length: 3 m)

	Description	Model
①	Controller setting software	JXC-MA1-1
②	USB cable	JXC-MA1-2 (The same cable as the JXC-W1-2)

\* Can be ordered separately

### Hardware Requirements

PC/AT compatible machine with Windows 7 or Windows 8.1 and USB1.1 or USB2.0 port

\*1 The controller setting software also includes software dedicated for 4 axes.

\* Windows® is a registered trademark of Microsoft Corporation in the United States.

## Options: Actuator Cable

[Robotic cable, standard cable for step motor (Servo/24 VDC)]

For 3 Axes JXC92    For 4 Axes JXC73/83/93

**LE-CP-1** - [ ] - [ ]

Cable length (L) [m]

1	1.5
3	3
5	5
8	8*1
A	10*1
B	15*1
C	20*1

\*1 Produced upon receipt of order (Robotic cable only)

**Cable type**

Nil	Robotic cable (Flexible cable)
S	Standard cable

**LE-CP-<sup>1</sup>/<sub>5</sub>**/Cable length: 1.5 m, 3 m, 5 m

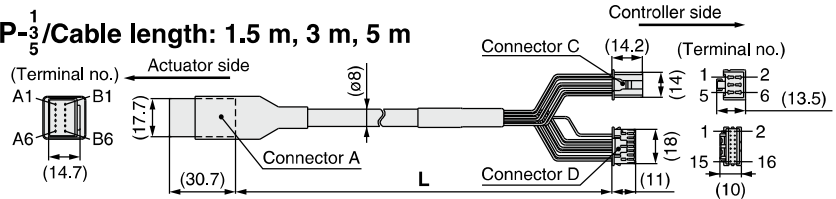

**LE-CP-<sup>8</sup>/<sub>AC</sub>**/Cable length: 8 m, 10 m, 15 m, 20 m  
(\*1 Produced upon receipt of order)

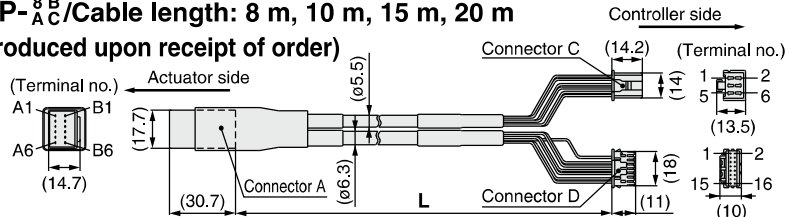

### Weight

Product no.	Weight [g]	Note
LE-CP-1-S	190	Standard cable
LE-CP-3-S	280	
LE-CP-5-S	460	
LE-CP-1	140	Robotic cable
LE-CP-3	260	
LE-CP-5	420	
LE-CP-8	790	
LE-CP-A	980	
LE-CP-B	1460	
LE-CP-C	1940	

Signal	Connector A terminal no.	Cable color	Connector C terminal no.
A	B-1	Brown	2
A	A-1	Red	1
B	B-2	Orange	6
B	A-2	Yellow	5
COM-A/COM	B-3	Green	3
COM-B/—	A-3	Blue	4
Shield			
Vcc	B-4	Brown	12
GND	A-4	Black	13
A	B-5	Red	7
A	A-5	Black	6
B	B-6	Orange	9
B	A-6	Black	8
		—	3

[Robotic cable, standard cable with lock and sensor for step motor (Servo/24 VDC)]

For 3 Axes JXC92    For 4 Axes JXC73/83/93

**LE-CP-1-B** - [ ] - [ ]

Cable length (L) [m]

1	1.5
3	3
5	5
8	8*1
A	10*1
B	15*1
C	20*1

\*1 Produced upon receipt of order (Robotic cable only)

**With lock and sensor**

**Cable type**

Nil	Robotic cable (Flexible cable)
S	Standard cable

**LE-CP-<sup>1</sup>/<sub>5</sub>**/Cable length: 1.5 m, 3 m, 5 m

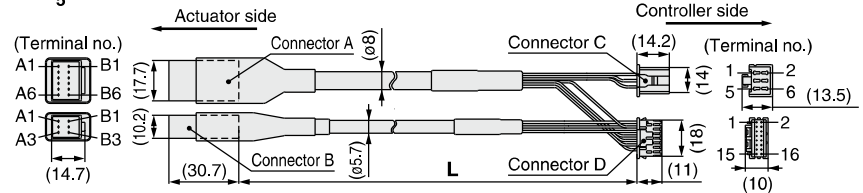

**LE-CP-<sup>8</sup>/<sub>AC</sub>**/Cable length: 8 m, 10 m, 15 m, 20 m  
(\*1 Produced upon receipt of order)

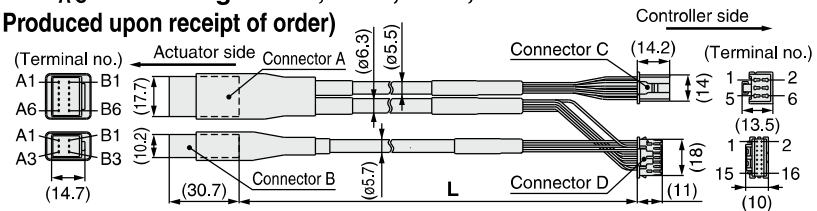

### Weight

Product no.	Weight [g]	Note
LE-CP-1-B-S	240	Standard cable
LE-CP-3-B-S	380	
LE-CP-5-B-S	630	
LE-CP-1-B	190	Robotic cable
LE-CP-3-B	360	
LE-CP-5-B	590	
LE-CP-8-B	1060	
LE-CP-A-B	1320	
LE-CP-C-B	2620	

Signal	Connector A terminal no.	Cable color	Connector C terminal no.
A	B-1	Brown	2
A	A-1	Red	1
B	B-2	Orange	6
B	A-2	Yellow	5
COM-A/COM	B-3	Green	3
COM-B/—	A-3	Blue	4
Shield			
Vcc	B-4	Brown	12
GND	A-4	Black	13
A	B-5	Red	7
A	A-5	Black	6
B	B-6	Orange	9
B	A-6	Black	8
		—	3
Signal	Connector B terminal no.	Cable color	Connector D terminal no.
Lock (+)	B-1	Red	4
Lock (-)	A-1	Black	5
Sensor (+)	B-3	Brown	1
Sensor (-)	A-3	Blue	2