

## Programmable transient voltage suppressor for SLIC protection

Datasheet - production data

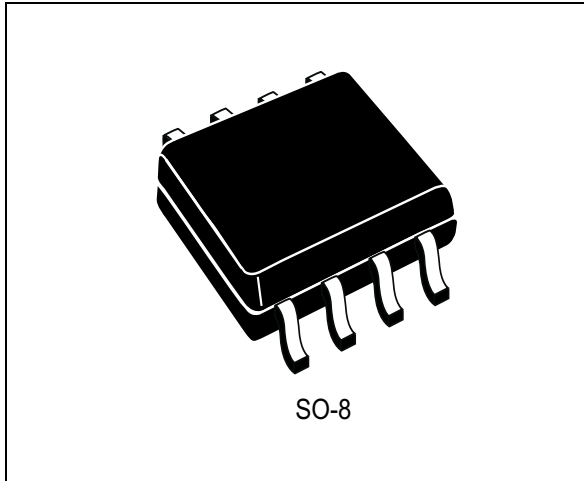

### Description

These devices have been especially designed to protect new high voltage, as well as classical SLICs, against transient overvoltages.

Positive overvoltages are clamped by 2 diodes. Negative surges are suppressed by 2 thyristors, their breakdown voltage being referenced to  $-V_{BAT}$  through the gate.

These components present a very low gate triggering current ( $I_{GT}$ ) in order to reduce the current consumption on printed circuit board during the firing phase.

### Features

- Programmable transient suppressor
- Wide negative firing voltage range:  $V_{Gn} = -175$  V max.
- Low dynamic switching voltages:  $V_{FP}$  and  $V_{DGL}$
- Low gate triggering current:  $I_{GT} = 5$  mA max.
- Peak pulse current:  $I_{PP} = 30$  A (10/1000  $\mu$ s)
- Holding current:  $I_H = 150$  mA min.

### Benefits

- Trisil™ is not subject to ageing and provides a fail safe mode in short circuit for a better level of protection.
- Trisils are used to ensure equipment meets various standards such as UL60950, IEC 950 / CSA C22.2, UL1459 and FCC part 68.
- Trisils have UL94 V0 approved resin (Trisils are UL497B approved [file: E136224]).

Figure 1. Functional diagram

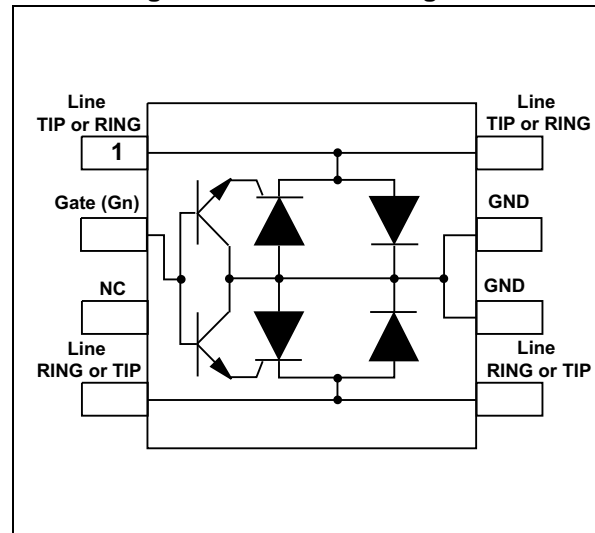

**TM:** Trisil is a trademark of STMicroelectronics

# 1 Characteristics

**Table 1. Standards compliance**

Standard	Peak surge voltage (V)	Voltage waveform	Required peak current (A)	Current waveform	Minimum serial resistor to meet standard ( $\Omega$ )
GR-1089 Core First level	2500	2/10 $\mu$ s	500	2/10 $\mu$ s	12
	1000	10/1000 $\mu$ s	100	10/1000 $\mu$ s	24
GR-1089 Core Second level	5000	2/10 $\mu$ s	500	2/10 $\mu$ s	24
GR-1089 Core Intra-building	1500	2/10 $\mu$ s	100	2/10 $\mu$ s	0
ITU-T-K20/K21	6000	10/700 $\mu$ s	150	5/310 $\mu$ s	110
	1500		37.5		0
ITU-T-K20 (IEC 61000-4-2)	8000	1/60 ns	ESD contact discharge		0
	15000		ESD air discharge		0
IEC 61000-4-5	4000	10/700 $\mu$ s	100	5/310 $\mu$ s	60
	4000	1.2/50 $\mu$ s	100	8/20 $\mu$ s	0
<b>TIA-968-A</b> , lightning surge type A	1500	10/160 $\mu$ s	200	10/160 $\mu$ s	22.5
	800	10/560 $\mu$ s	100	10/560 $\mu$ s	15
<b>TIA-968-A</b> , lightning surge type B	1000	9/720 $\mu$ s	25	5/320 $\mu$ s	0

**Table 2. Thermal resistances**

Symbol	Parameter	Value	Unit
$R_{th(j-a)}$	Junction to ambient	120	$^{\circ}\text{C}/\text{W}$

Table 3. Absolute ratings ( $T_{amb} = 25\text{ }^{\circ}\text{C}$ )

Symbol	Parameter	Value	Unit	
$I_{PP}$	Peak pulse current <sup>(1)</sup>	10/1000 $\mu\text{s}$	30	A
		8/20 $\mu\text{s}$	100	
		10/560 $\mu\text{s}$	35	
		5/310 $\mu\text{s}$	40	
		10/160 $\mu\text{s}$	50	
		1/20 $\mu\text{s}$	100	
		2/10 $\mu\text{s}$	150	
$I_{TSM}$	Non repetitive surge peak on-state current (50 Hz sinusoidal) <sup>(1)</sup>	t = 20 ms	18	A
		t = 200 ms	10	
		t = 1 s	7	
$V_{Gn}$	Negative battery voltage range	-40 $^{\circ}\text{C} < T_{amb} < +85\text{ }^{\circ}\text{C}$	-175	V
$T_{stg}$	Storage temperature range		-55 to +150	$^{\circ}\text{C}$
$T_j$	Operating junction temperature range		-55 to +150	
$T_L$	Maximum lead temperature for soldering during 10 s.		260	$^{\circ}\text{C}$

1. The rated current values may be applied either to the RING to GND or to the Tip to GND terminal pairs. Additionally, both terminal pairs may have their rated current values applied simultaneously (in this case the GND terminal current will be twice the rated current value of an individual terminal pair).

Figure 2. Electrical characteristics (definitions)

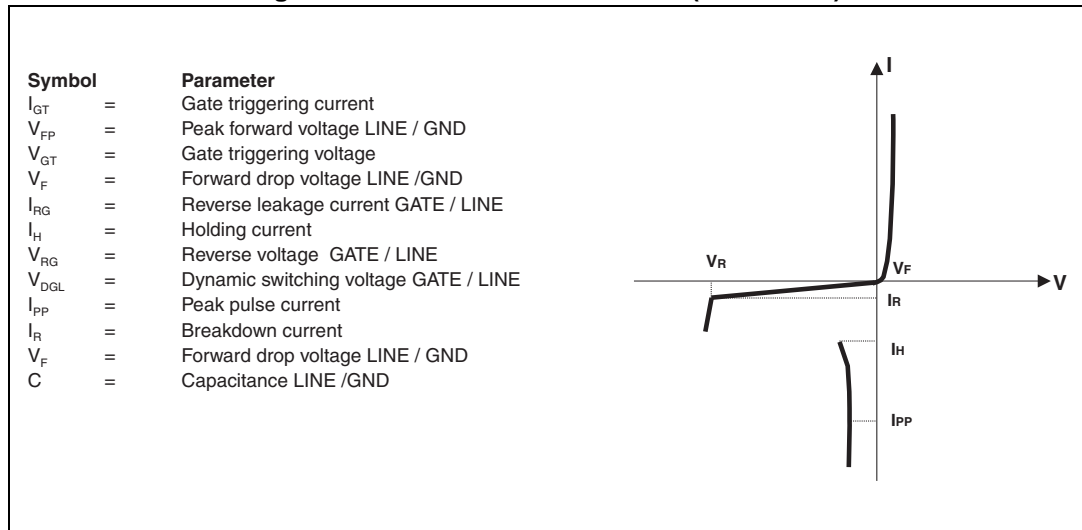

Figure 3. Pulse waveform

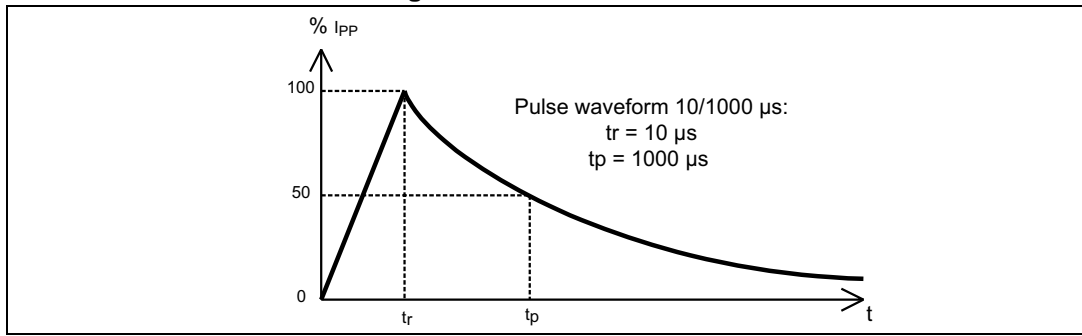

Table 4. Parameters related to the diode LINE / GND (T<sub>amb</sub> = 25 °C)

Symbol	Test conditions			Max.	Unit
V <sub>F</sub>	I <sub>F</sub> = 5 A		t = 500 μs	3	V
V <sub>FP</sub>	10/700 μs	1.5 kV	R <sub>S</sub> = 10 Ω	5	V
	1.2/50 μs	1.5 kV	R <sub>S</sub> = 10 Ω	9	
	2/10 μs	2.5 kV	R <sub>S</sub> = 62 Ω	30	

Table 5. Parameters related to the protection thyristors (T<sub>amb</sub> = 25 °C)

Symbol	Test conditions				Min.	Max.	Unit
I <sub>GT</sub>	V <sub>LINE</sub> = -48 V				0.1	5	mA
I <sub>H</sub>	V <sub>Gn</sub> = -48 V				150		mA
V <sub>GT</sub>	at I <sub>GT</sub>					2.5	V
I <sub>RG</sub>	V <sub>RG</sub> = -175 V		T <sub>J</sub> = 25 °C			5	μA
	V <sub>RG</sub> = -175 V		T <sub>J</sub> = 85 °C			50	
V <sub>DGL</sub>	V <sub>Gn</sub> = -48 V <sup>(1)</sup>						V
	10/700 μs	1.5 kV	R <sub>S</sub> = 10 Ω	I <sub>PP</sub> = 30 A		7	
	1.2/50 μs	1.5 kV	R <sub>S</sub> = 10 Ω	I <sub>PP</sub> = 30 A		10	
	2/10 μs	2.5 kV	R <sub>S</sub> = 62 Ω	I <sub>PP</sub> = 38 A		25	

1. The oscillations with a time duration lower than 50 ns are not taken into account.

Table 6. Parameters related to diode and protection thyristors (T<sub>amb</sub> = 25 °C)

Symbol	Test conditions			Typ.	Max.	Unit
I <sub>R</sub>	V <sub>Gn</sub> / LINE = -1 V	V <sub>LINE</sub> = -175 V	T <sub>J</sub> = 25 °C		5	μA
	V <sub>Gn</sub> / LINE = -1 V	V <sub>LINE</sub> = -175 V	T <sub>J</sub> = 85 °C		50	
C	V <sub>LINE</sub> = -50 V, V <sub>RMS</sub> = 1 V, F = 1 MHz			15		pF
	V <sub>LINE</sub> = -2 V, V <sub>RMS</sub> = 1 V, F = 1 MHz			35		

Table 7. Recommended gate capacitance

Symbol	Component	Min.	Typ.	Max.	Unit
C <sub>G</sub>	Gate decoupling capacitance	100	220		nF

## 2 Technical information

Figure 4. LCP concept behavior

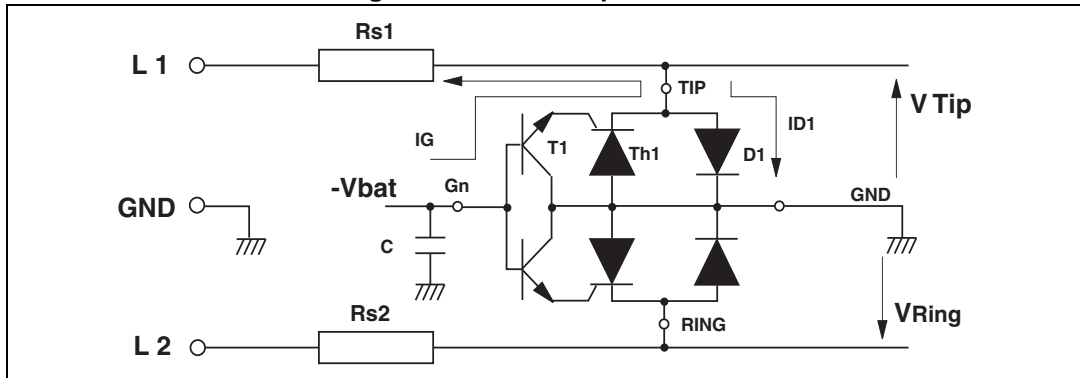

Figure 4 shows the classical protection circuit using the LCP crowbar concept. This topology has been developed to protect the new high voltage SLICs. It allows to program the negative firing threshold while the positive clamping value is fixed at GND.

When a negative surge occurs on one wire (L1 for example) a current  $I_G$  flows through the base of the transistor T1 and then injects a current in the gate of the thyristor Th1. Th1 fires and all the surge current flows through the ground. After the surge when the current flowing through Th1 becomes less negative than the holding current  $I_H$ , then Th1 switches off.

When a positive surge occurs on one wire (L1 for example) the diode D1 conducts and the surge current flows through the ground.

Figure 5. Example of PCB layout based on LCP1521S protection

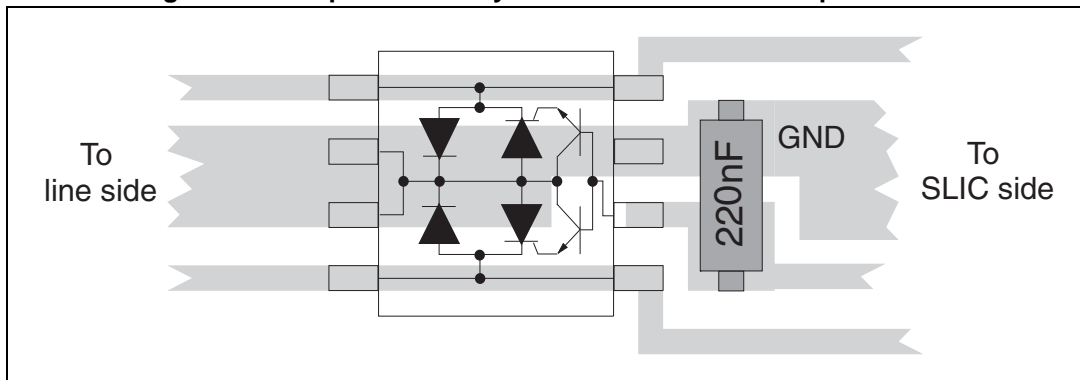

Figure 5 shows the classical PCB layout used to optimize line protection.

The capacitor C is used to speed up the crowbar structure firing during the fast surge edges.

This allows minimization of the dynamic breakover voltage at the SLIC Tip and Ring inputs during fast strikes. Note that this capacitor is generally present around the SLIC - Vbat pin.

So to be efficient it has to be as close as possible from the LCP Gate pin and from the reference ground track (or plan) (see Figure 5). The optimized value for C is 220 nF.

The series resistors Rs1 and Rs2 designed in [Figure 4](#) represent the fuse resistors or the PTC which are mandatory to withstand the power contact or the power induction tests imposed by the various country standards. Taking into account this fact the actual lightning surge current flowing through the LCP is equal to:

$$I_{\text{surge}} = V_{\text{surge}} / (R_g + R_s)$$

With:

$V_{\text{surge}}$  = peak surge voltage imposed by the standard.

$R_g$  = series resistor of the surge generator

$R_s$  = series resistor of the line card (e.g. PTC)

e.g. For a line card with 30 Ω of series resistors which has to be qualified under GR1089 core 1000V 10/1000 μs surge, the actual current through the LCP is equal to:

$$I_{\text{surge}} = 1000 / (10 + 30) = 25 \text{ A}$$

The LCP is particularly optimized for the new telecom applications such as the fiber in the loop, the WLL, the remote central office. In this case, the operating voltages are smaller than in the classical system. This makes the high voltage SLICs particularly suitable.

The schematics of [Figure 6](#) give the most frequent topology used for these applications.

Figure 6. Protection of high voltage SLIC

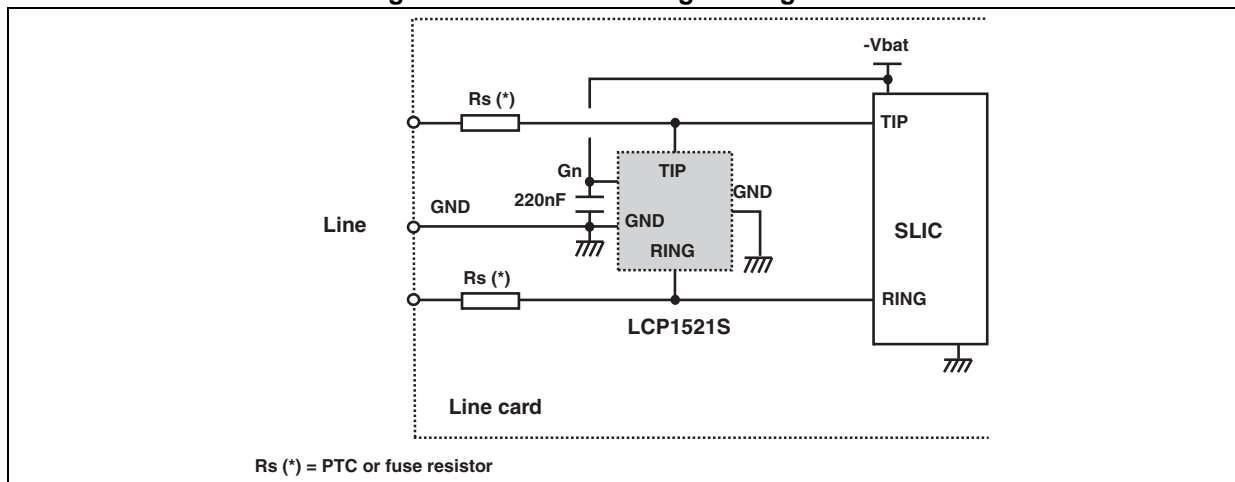

Figure 7. Surge peak current versus duration

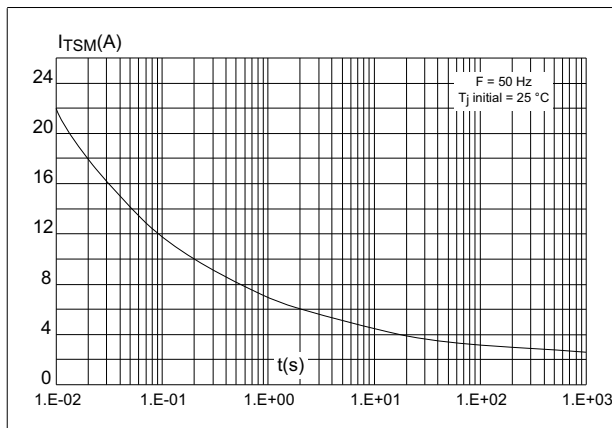
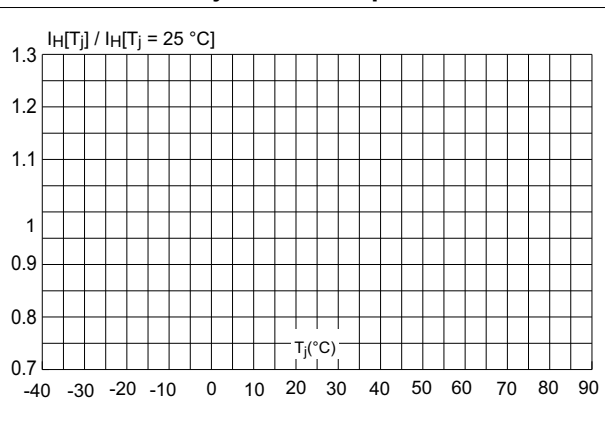

Figure 8. Relative variation of holding current versus junction temperature



### 3 Package information

- Epoxy meets UL94, V0

In order to meet environmental requirements, ST offers these devices in different grades of ECOPACK® packages, depending on their level of environmental compliance. ECOPACK® specifications, grade definitions and product status are available at: [www.st.com](http://www.st.com). ECOPACK® is an ST trademark.

#### 3.1 SO-8 package information

Figure 9. SO-8 package outline

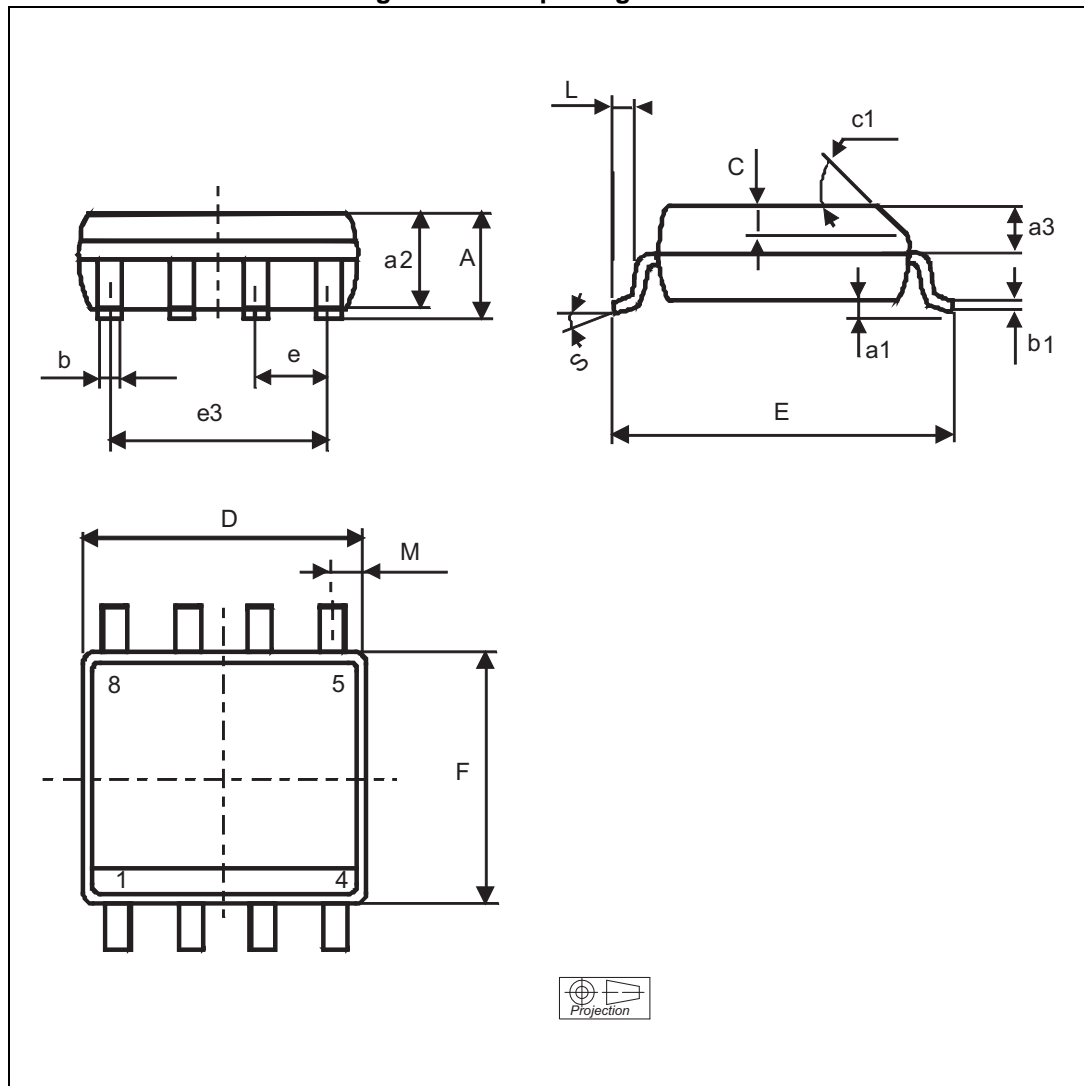
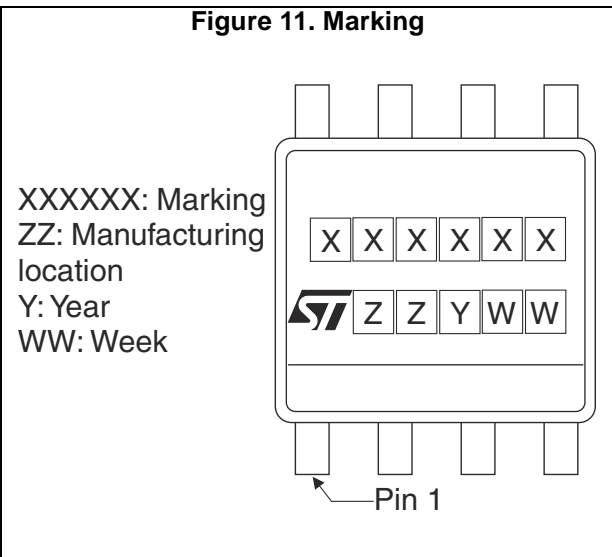
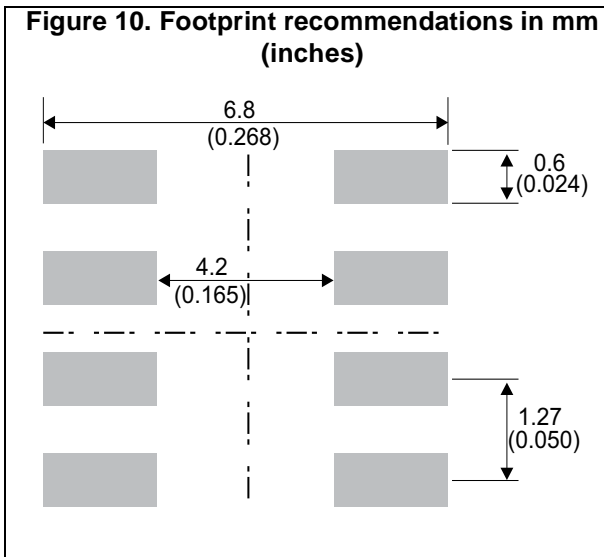

Table 8. SO-8 package mechanical data

Ref.	Dimensions					
	Millimeters			Inches		
	Min.	Typ.	Max.	Min.	Typ.	Max.
A			1.75			0.069
A1	0.1		0.25	0.004		0.010
A2	1.25			0.049		
b	0.28		0.48	0.011		0.019
C	0.17		0.23	0.007		0.009
D	4.80	4.90	5.00	0.189	0.193	0.197
E	5.80	6.00	6.20	0.228	0.236	0.244
E1	3.80	3.90	4.00	0.150	0.154	0.157
e		1.27			0.050	
h	0.25		0.50	0.010		0.020
L	0.40		1.27	0.016		0.050
L1		1.04			0.041	
k°	0		8	0		8
ccc			0.10			0.004



## 4 Ordering information

Table 9. Ordering information

Order code	Marking	Package	Weight	Base qty	Delivery mode
LCP1521SRL	CP152S	SO-8	0.08 g	2500	Tape and reel

## 5 Revision history

Table 10. Document revision history

Date	Revision	Changes
20-Nov-2009	1	First issue.
23-Feb-2012	2	Standardized nomenclature for Gn.
15-Nov-2013	3	Updated <a href="#">Figure 9</a> .
10-Apr-2015	4	Updated <a href="#">Figure 1</a> , <a href="#">Figure 10</a> and package view. Added <a href="#">Figure 11</a> . Updated <a href="#">Table 3</a> and <a href="#">Table 9</a> .

**IMPORTANT NOTICE – PLEASE READ CAREFULLY**

STMicroelectronics NV and its subsidiaries (“ST”) reserve the right to make changes, corrections, enhancements, modifications, and improvements to ST products and/or to this document at any time without notice. Purchasers should obtain the latest relevant information on ST products before placing orders. ST products are sold pursuant to ST’s terms and conditions of sale in place at the time of order acknowledgement.

Purchasers are solely responsible for the choice, selection, and use of ST products and ST assumes no liability for application assistance or the design of Purchasers’ products.

No license, express or implied, to any intellectual property right is granted by ST herein.

Resale of ST products with provisions different from the information set forth herein shall void any warranty granted by ST for such product.

ST and the ST logo are trademarks of ST. All other product or service names are the property of their respective owners.

Information in this document supersedes and replaces information previously supplied in any prior versions of this document.

© 2015 STMicroelectronics – All rights reserved