

# **W-LAN+Bluetooth Combo Module Data Sheet**

**Broadcom Chipset**  
**for 802.11b/g/n + Bluetooth 4.1/EDR**

**Sample P/N : LBEE5KL1DX-TEMP**

## The revision history of the product specification

Issued Date	Revision Code	Revision Page	Changed Items	Change Reason
Dec.1, 2014	-	-	First Issue	
Dec.4, 2014	A	P.4 P.8	m1 and m2 of Dimensions. VDDIO of Rating.	Correction
Jan.23, 2015	B	P.4	Dimensions	Correction
Feb.9, 2015	C	P.3	Block Diagram	Correction
Mar.4, 2015	D	P.8 P.15-17	VBAT voltage DC/RF Characteristics	Correction
Mar.26, 2015	E	P.5 P.15-18 P.17 P.20 P.21-23	Terminal Configurations (16)  Characteristics (Fix values on items described TBD)  Conditions VBAT voltage  Reference circuit  Tape and Reel Packing	Correction Spec. fixed
Jun.19, 2015	F	P7 P19	Add note of SDIO Add BLE spec	
Jul.21, 2015	G	P8  P23	Conditions VBAT voltage Specification Temperature Range  Add recommend parts name	Correction
Aug.26 2015	H	P14-17	Typ values	Addition
Sep. 26. 2015	I	P4 P23	4. Dimensions, Marking and Terminal Configurations 11. Land pattern	Addition
Feb.8.2016	J	P22	Add BLE Rx spec	Addition
Feb.29.2016	K	P4 P5 P6	Add marking information  Terminal Conditions(14)  6.2 Power Up Sequence	Addition Correction Correction
Mar.18.2016	L	P4 P6	Add structure  Terminal Conditions(37)	Addition Correction

## TABLE OF CONTENTS

1. Scope .....	3
2. Part Number .....	3
3. Block Diagram.....	3
4. Dimensions, Marking and Terminal Configurations .....	4
5. Rating .....	8
6. Operating Condition .....	8
6.1. Operating condition .....	8
6.2. Power Up Sequence.....	8
7. Digital I/O Requirements .....	12
8. External LPO Specification.....	12
9. Interface Timing .....	13
9.1. SDIO Timing (Default Mode) .....	13
9.2. SDIO Timing (High Speed Mode) .....	14
9.3. Bluetooth UART Timing (Default Mode) .....	14
9.4. PCM Timing Short Frame Sync, Master Mode.....	15
9.5. PCM Timing Short Frame Sync, Slave Mode .....	16
9.6. PCM Timing Long Frame Sync, Master Mode.....	16
9.7. PCM Timing Long Frame Sync, Slave Mode .....	17
10. DC/RF Characteristics.....	18
10.1. DC/RF Characteristics for IEEE802.11b.....	18
10.2. DC/RF Characteristics for IEEE802.11g.....	19
10.3. DC/RF Characteristics for IEEE802.11n.....	20
10.4. DC/RF Characteristics for Bluetooth.....	21
10.5. DC/RF Characteristics for Bluetooth(LE) .....	22
11. Land pattern.....	23
12. Reference Circuit .....	24
13. Tape and Reel Packing .....	25
14. NOTICE.....	28
14.1. Storage Conditions:.....	28
14.2. Handling Conditions: .....	28
14.3. Standard PCB Design (Land Pattern and Dimensions): .....	28
14.4. Notice for Chip Placer:.....	28
14.5. Soldering Conditions:.....	29
14.6. Cleaning:.....	29
14.7. Operational Environment Conditions: .....	29
14.8. Input Power Capacity: .....	30
15. PRECONDITION TO USE OUR PRODUCTS.....	31

Please be aware that an important notice concerning availability, standard warranty and use in critical applications of Murata products and disclaimers thereto appears at the end of this specification sheet.

### 1. Scope

This specification is applied to the IEEE802.11b/g/n W-LAN + Bluetooth 4.1+EDR module.

- Interface : SDIO (WLAN), UART (BT)
- IC/Firmware : Broadcom/BCM4343W
- Reference Clock : Reference clock is embedded.
- MSL : Level 3
- RoHS : This module is compliant with the RoHS directive.

### 2. Part Number

Sample Part Number	LBEE5KL1DX-TEMP
EVK Part Number	LBEE5KL1DX-TEMP-D

### 3. Block Diagram

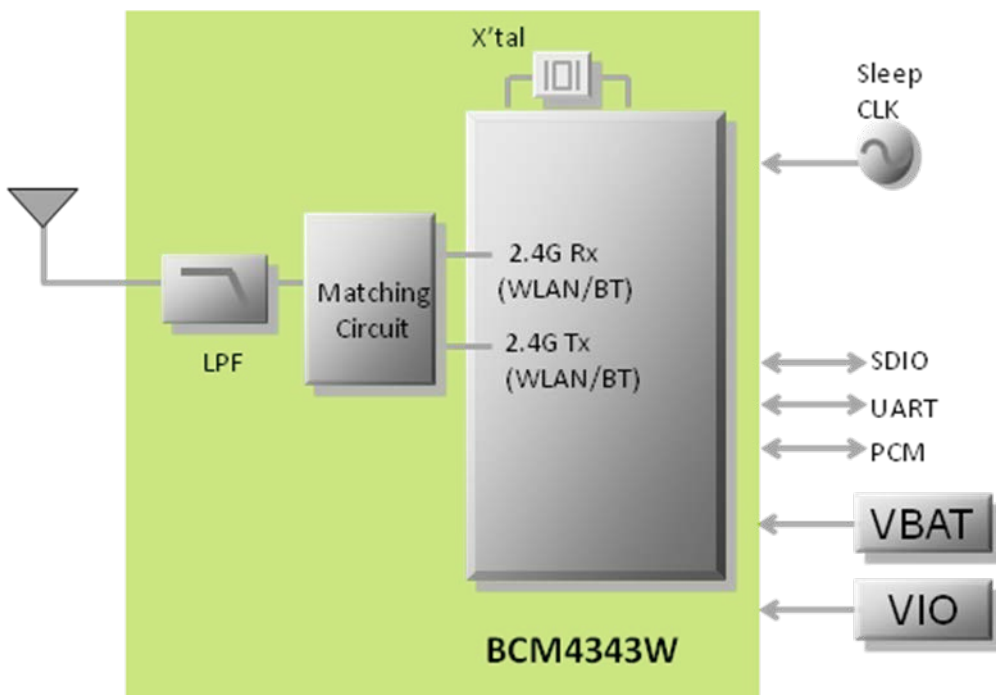



**4. Dimensions, Marking and Terminal Configurations**

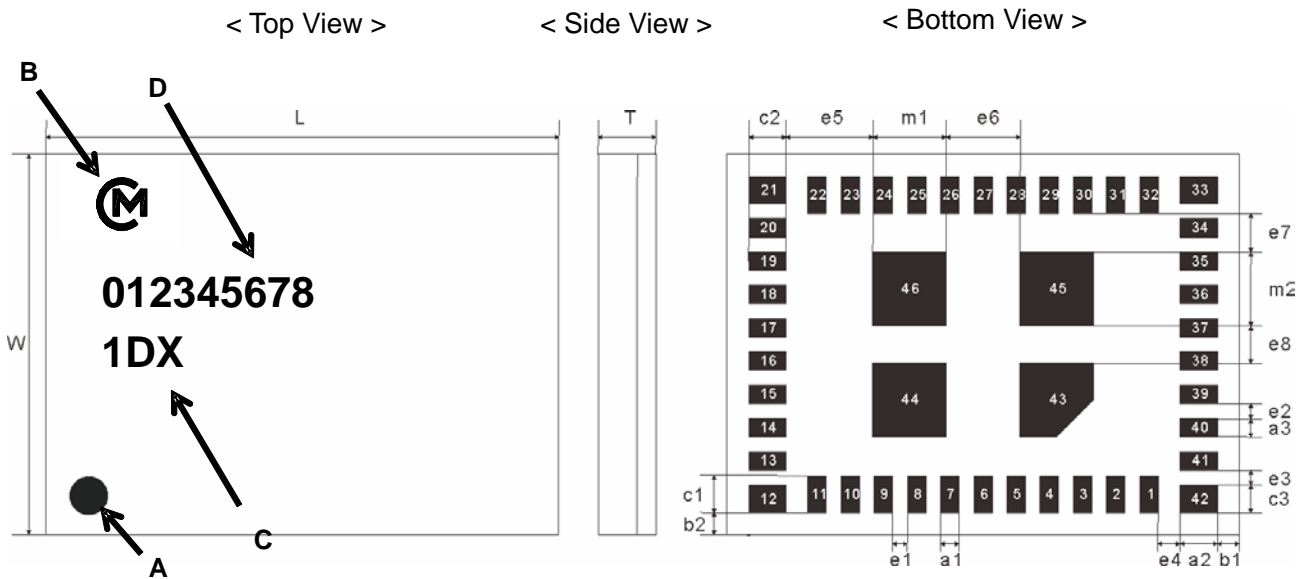

Marking	Meaning
A	Pin 1 Marking
B	Murata Logo
C	Module Type
D	Inspection Number

**Dimensions**

(unit : mm)

Mark	Dimensions	Mark	Dimensions	Mark	Dimensions
L	6.95 +/- 0.2	W	5.15 +/- 0.2	T	1.1 max.
a1	0.25 +/- 0.10	a2	0.5 +/- 0.1	a3	0.25 +/- 0.10
b1	0.30 +/- 0.2	b2	0.30 +/- 0.2	c1	0.50 +/- 0.1
c2	0.50 +/- 0.1	c3	0.375 +/- 0.100	e1	0.2 +/- 0.1
e2	0.2 +/- 0.1	e3	0.2 +/- 0.1	e4	0.3 +/- 0.1
e5	1.175 +/- 0.100	e6	1.0 +/- 0.1	e7	0.525 +/- 0.100
e8	0.50 +/- 0.10	m1	1.0 +/- 0.1	m2	1.0 +/- 0.1
m3	0.5 +/- 0.1	m4	0.5 +/- 0.1		

**Structure**

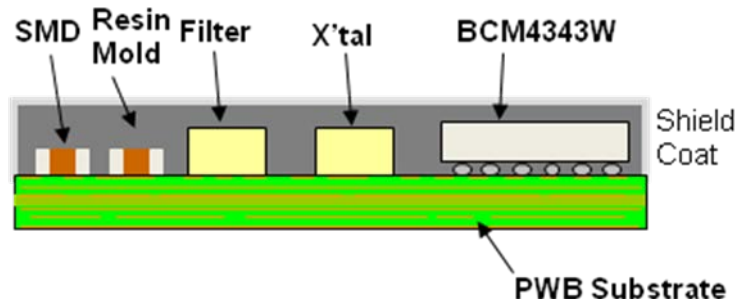

## Terminal Configurations

No.	Terminal Name	Type	Connection to IC Terminal	Description
(1)	GND			
(2)	BT_UART_RXD	I	BT_UART_RXD	UART serial input. Serial data input for the HCI UART interface.
(3)	BT_UART_TXD	O	BT_UART_TXD	UART serial output. Serial data output for the HCI UART interface.
(4)	BT_UART_CTS_N	I	BT_UART_CTS_N	UART clear-to-send. Active-low clear-to-send signal for the HCI UART interface.
(5)	BT_UART_RTS_N	O	BT_UART_RTS_N	UART request-to-send. Active-low request-to-send signal for the HCI UART interface.
(6)	BT_GPIO_3		BT_GPIO_3	
(7)	BT_GPIO_4		BT_GPIO_4	
(8)	BT_PCM_SYNC	I/O	BT_PCM_SYNC	PCM sync; can be master (output) or slave (input)
(9)	BT_PCM_IN	I	BT_PCM_IN	PCM data input sensing
(10)	BT_PCM_OUT	O	BT_PCM_OUT	PCM data output
(11)	BT_PCM_CLK	I/O	BT_PCM_CLK	PCM clock; can be master (output) or slave (input)
(12)	GND			
(13)	BT_GPIO_5		BT_GPIO_5	
(14)	BT_REG_ON	I	BT_REG_ON	Used by PMU to power up or power down the internal regulators used by the Bluetooth section. Also, when deasserted, this pin holds the Bluetooth section in reset. This pin has an internal 200k $\Omega$ pull-down resistor that is enabled by default. It can be disabled through programming.
(15)	WL_GPIO_4		GPIO_4	
(16)	BT_I2S_dO			
(17)	WL_GPIO_2		GPIO_2	
(18)	WL_GPIO_1		GPIO_1	
(19)	GND			
(20)	SDIO_CLK	I		SDIO clock input



(21)	GND			
(22)	SDIO_CMD	I/O	SDIO_CMD	SDIO command line
(23)	SDIO_DATA_2	I/O	SDIO_DATA_2	SDIO data line 2
(24)	SDIO_DATA_0	I/O	SDIO_DATA_0	SDIO data line 0
(25)	SDIO_DATA_3	I/O	SDIO_DATA_3	SDIO data line 3
(26)	SDIO_DATA_1	I/O	SDIO_DATA_1	SDIO data line 1
(27)	WL_GPIO_0_HOST_WAKE		GPIO_0	
(28)	WL_REG_ON	I	WL_REG_ON	Used by PMU to power up or power down the internal regulators used by the WLAN section. Also, when deasserted, this pin holds the WLAN section in reset. This pin has an internal 200k $\Omega$ pull-down resistor that is enabled by default. It can be disabled through programming.
(29)	GND			
(30)	VBAT		LDO_VDDBAT5V, SR_VDDBAT5V	
(31)	VIN_LDO		LDO_VDD1P5, WLRV_VDD_1P35	
(32)	GND (SR_PVSS)			
(33)	GND (SR_PVSS)			
(34)	SR_VLX		SR_VLX	CBUCK switching regulator output.
(35)	GND			
(36)	VIO		SCC_VDDIO, SYS_VDDIO	
(37)	LPO_IN (32kHz)	I	LPO_IN	External sleep clock input (32.768kHz).
(38)	BT_HOST_WAKE	I/O	BT_HOST_WAKE	HOST_WAKE or general-purpose I/O signal
(39)	BT_DEV_WAKE	I/O	BT_DEV_WAKE	DEV_WAKE or general-purpose I/O signal
(40)	GND			
(41)	ANT			
(42) ~ (46)	GND			



SDIO Pin Description

No.	Pin Name	(i) SD 4-bit Mode		(ii) SD 1-bit Mode	
20	SDIO_CLK	CLK	Clock	CLK	Clock
24	SDIO_D0	DATA0	Data line 0	DATA	Data line
26	SDIO_D1	DATA1	Data line 1 /Interrupt	IRQ	Interrupt
23	SDIO_D2	DATA2	Data line 2	NC	Not used
25	SDIO_D3	DATA3	Data line 3	NC	Not used
22	SDIO_CMD	CMD	Command line	CMD	Command line

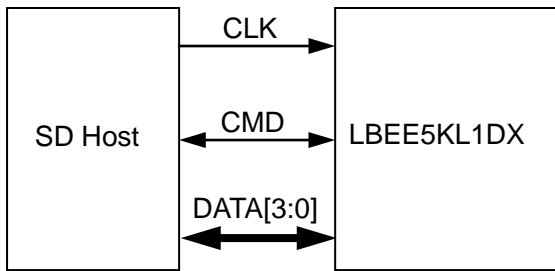

(i) SD 4-bit Mode

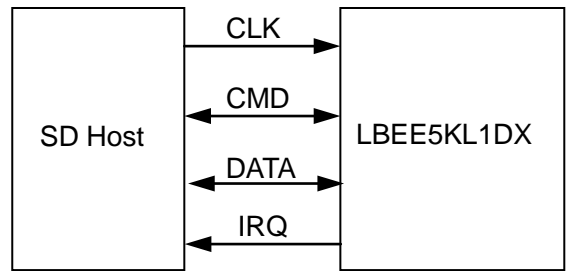

(ii) SD 1-bit Mode

Note : 10 to 100kΩ pull-ups are required on the four DATA lines and the CMD line. This requirement must be met during all operating states by using external pull-up resistors or properly programming internal SDIO host pull-ups.

UART connection

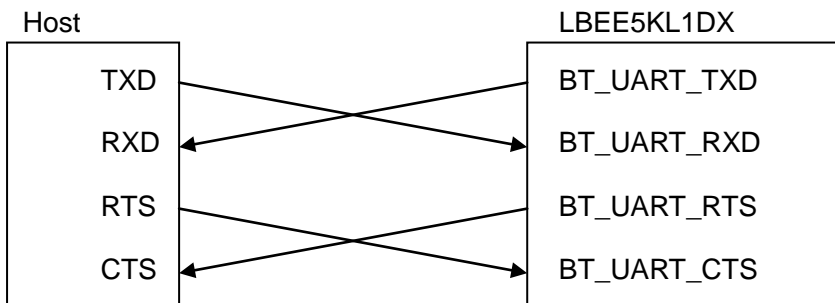

UART Connection



## 5. Rating

		min.	max.	unit
Storage Temperature		-40	+85	deg.C
Supply Voltage	VBAT	-0.5	5.0	V
	VDDIO	-0.5	3.9	V

\* Stresses in excess of the absolute ratings may cause permanent damage. Functional operation is not implied under these conditions. Exposure to absolute ratings for extended periods of time may adversely affect reliability. No damage assuming only one parameter is set at limit at a time with all other parameters are set within operating condition.

## 6. Operating Condition

### 6.1. Operating condition

		min.	typ.	max.	unit
Operating Temperature Range		-30	+25	+70	deg.C
Specification Temperature Range		-10	+25	+55	deg.C
Operating Voltage	VBAT	3.0	3.6	4.8	V
	VDDIO	1.71	1.8 or 3.3	3.63	V
Specification Voltage	VBAT	3.2	3.6	4.2	V
	VDDIO	1.71	1.8 or 3.3	3.63	V

[Note] All RF characteristics in this datasheet are defined by Specification Temperature Range and Specification Voltage.

### 6.2. Power Up Sequence

-VBAT should not rise 10%-90% faster than 40 microsecond.

-VBAT should be up before or at the same time as VIO. VIO should NOT be present fast or be held high before VBAT is high.

#### Power On Sequence for WLAN ON and BT ON

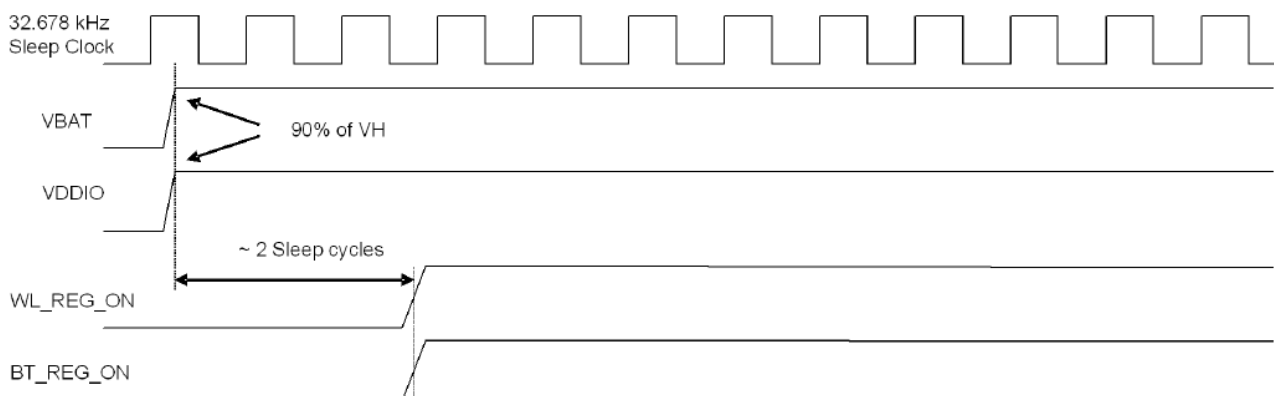



### Power On Sequence for WLAN ON and BT Off

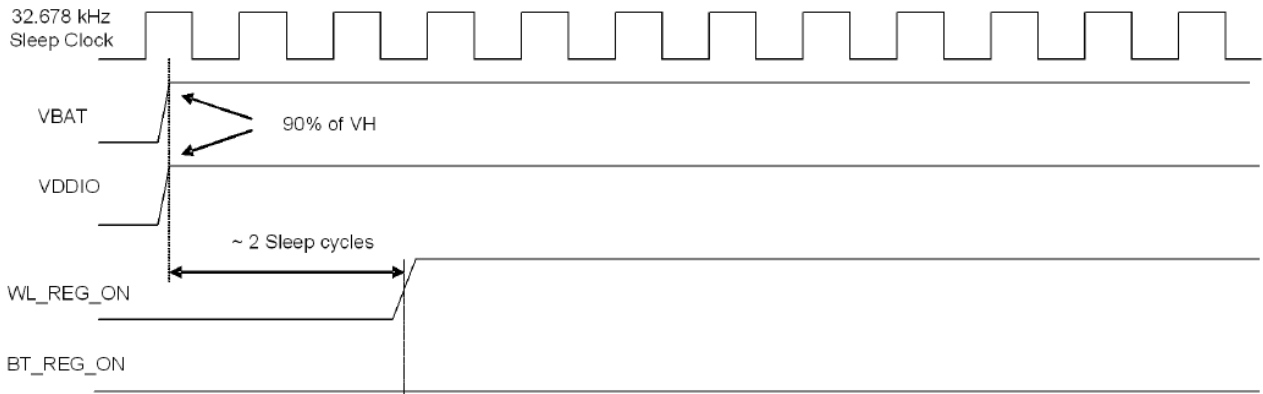

### Power On Sequence for WLAN OFF and BT ON

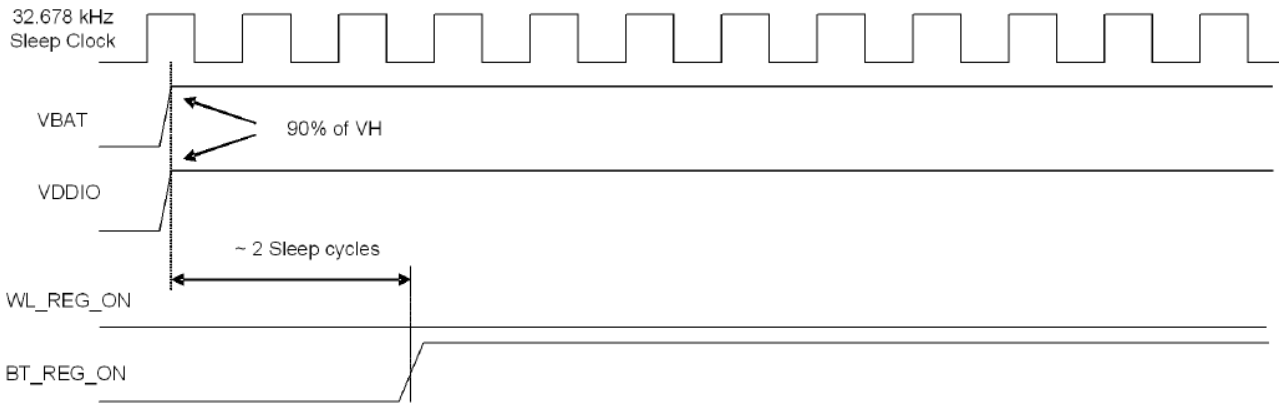

### Power On Sequence for WLAN OFF and BT OFF

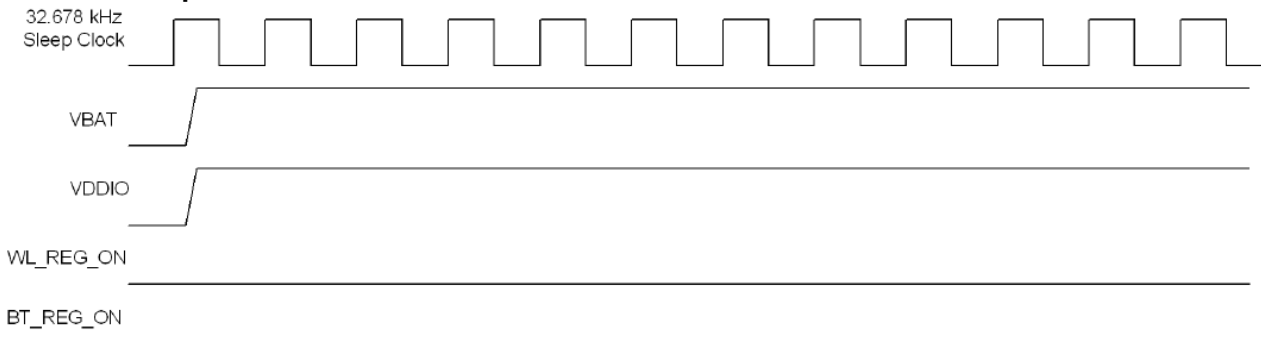



### WLAN Boot up Sequence

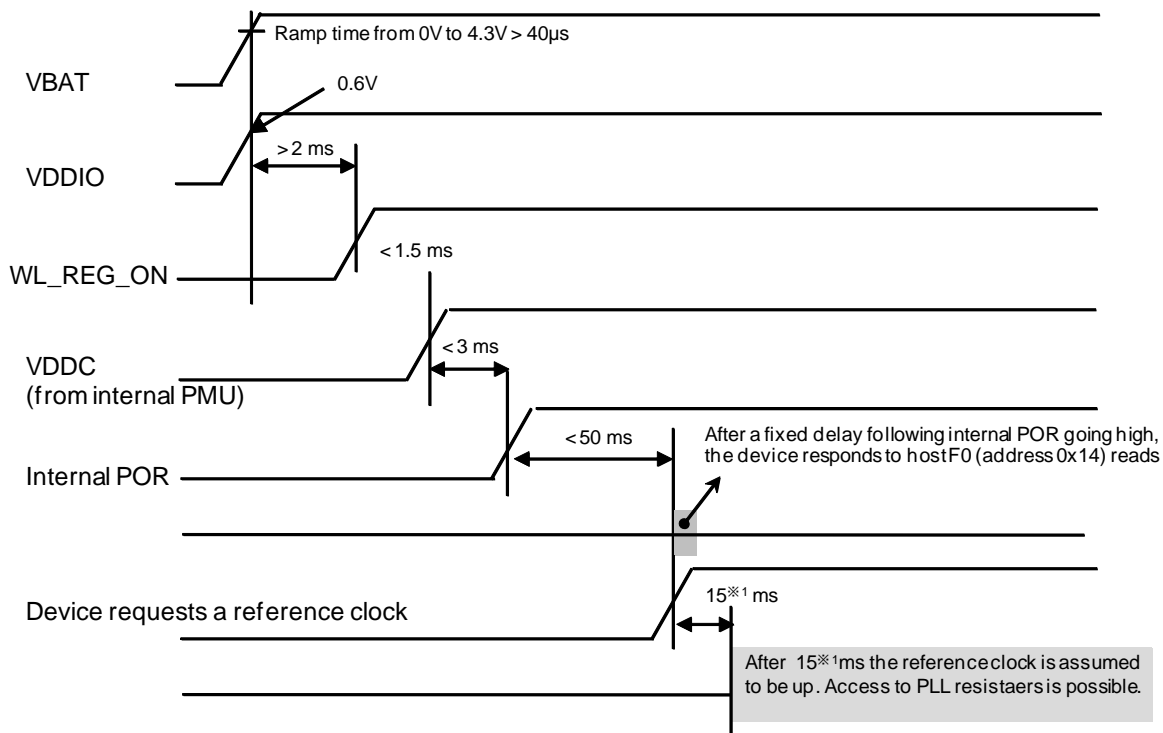

※1 This wait time is programmable in sleep-clock increments from 1 to 255 (30us to 15ms)



### Startup Signaling Sequence

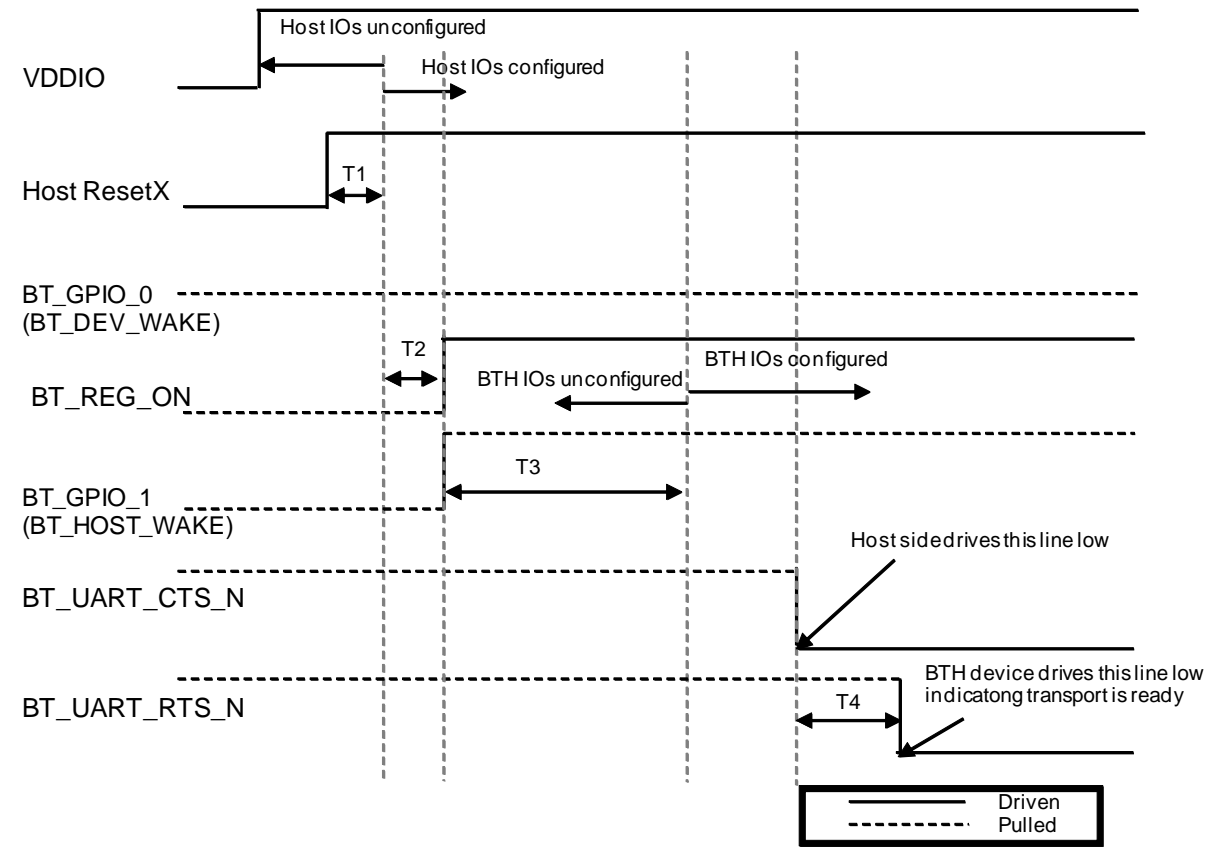

T1 is the time for host to settle it's IOs after a reset.

T2 is the time for host to drive BT\_REG\_ON high after the Host IOs are configured.

T3 is the time for BTH(Bluetooth) device to settle its IOs after a reset and reference clock settling time has elapsed.

T4 is the time for BTH device to drive BT\_UART\_RTS\_N low after the host drives BT\_UART\_CTS\_N low. This assumes the BTH device has already completed initialization.

Timing diagram assumes VBAT is present.



## 7. Digital I/O Requirements

SDIO Interface I/O Pins	Sym	min.	max.	unit
Input low voltage (VDDIO = 3.3V)	V <sub>IL</sub>	-	0.25*VDDIO	V
Input high voltage (VDDIO = 3.3V)	V <sub>IH</sub>	0.625*VDDIO	-	V
Input low voltage (VDDIO = 1.8V) <sup>1</sup>	V <sub>IL</sub>	-	0.58	V
Input high voltage (VDDIO = 1.8V)	V <sub>IH</sub>	1.27	-	V
Output low voltage (VDDIO = 3.3V)	V <sub>OL</sub>	-	0.125*VDDIO	V
Output high voltage (VDDIO = 3.3V)	V <sub>OH</sub>	0.75*VDDIO	-	V
Output low voltage (VDDIO = 1.8V)	V <sub>OL</sub>	-	0.45	V
Output high voltage (VDDIO = 1.8V)	V <sub>OH</sub>	1.40	-	V

Other Digital I/O Pins	Sym	min.	max.	unit
Input low voltage (VDDIO = 3.3V)	V <sub>IL</sub>	-	0.8	V
Input high voltage (VDDIO = 3.3V)	V <sub>IH</sub>	2.0	-	V
Input low voltage (VDDIO = 1.8V) <sup>1</sup>	V <sub>IL</sub>	-	0.35*VDDIO	V
Input high voltage (VDDIO = 1.8V)	V <sub>IH</sub>	0.65*VDDIO	-	V
Output low voltage (VDDIO = 3.3V)	V <sub>OL</sub>	-	0.40	V
Output high voltage (VDDIO = 3.3V)	V <sub>OH</sub>	VDDIO-0.4	-	V
Output low voltage (VDDIO = 1.8V)	V <sub>OL</sub>	-	0.45	V
Output high voltage (VDDIO = 1.8V)	V <sub>OH</sub>	VDDIO-0.45	-	V

## 8. External LPO Specification

Parameter	Condition/Notes	Specification			
		Minimum	Typical	Maximum	Units
Frequency	-	-	32.768	-	KHz
Frequency accuracy		-200	-	+200	ppm
Duty cycle	-	30	-	70	%
Input amplitude		200	-	3300	mV, p-p
Signal type	Square wave or sine wave	-	-	-	-
Input impedance <sup>a</sup>	Resistive	100	-	-	kΩ
	Capacitive	-	-	5	pF
Clock jitter		-	-	10,000	ppm

a. When power is applied or switched off.

## 9. Interface Timing

### 9.1. SDIO Timing (Default Mode)

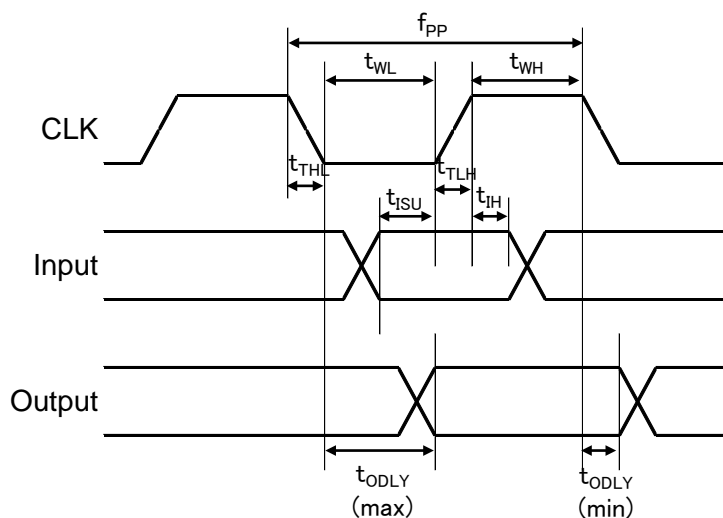

Parameter	Symbol	Min <sup>(1)</sup>	Typ <sup>(1)</sup>	Max <sup>(1)</sup>	Unit
Clock CLK (All values are referred to min. VIH and max. VIL <sup>(2)</sup> )					
Frequency-Data Transfer Mode	fPP	0	-	25	MHz
Frequency-Identification Mode	fOD	0	-	400	kHz
Clock Low Time	tWL	10	-	-	ns
Clock High Time	tWH	10	-	-	ns
Clock Rise Time	tTLH	-	-	10	ns
Clock Fall Time	tTHL	-	-	10	ns
Inputs: CMD, DAT (referenced to CLK)					
Input Setup Time	tISU	5	-	-	ns
Input Hold Time	tIH	5	-	-	ns
Outputs: CMD, DAT (referenced to CLK)					
Output Delay time-Data Transfer Mode	tODLY	0	-	14	ns
Output Delay time-Identification Mode	tODLY	0	-	50	ns

(1). Timing is based on  $CL \leq 40\text{pF}$  load on CMD and Data.

(2). Min (Vih) =  $0.7 \cdot VDDIO$  and max (Vil) =  $0.2 \cdot VDDIO$ .



### 9.2. SDIO Timing (High Speed Mode)

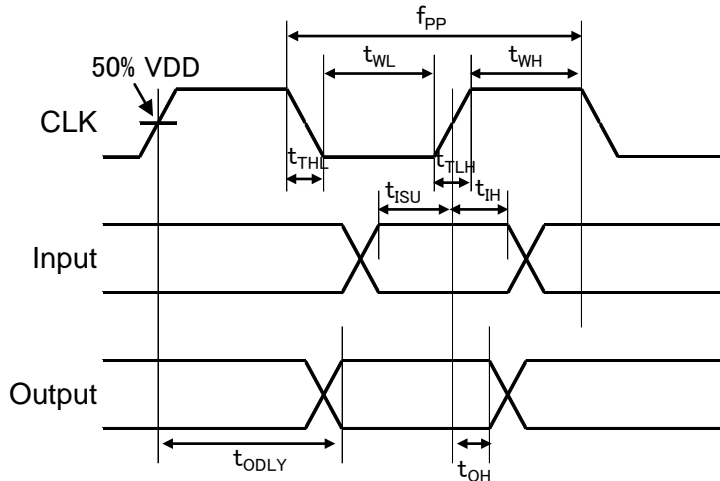

Parameter	Symbol	Min <sup>(1)</sup>	Typ <sup>(1)</sup>	Max <sup>(1)</sup>	Unit
Clock CLK (All values are referred to min. VIH and max. VIL <sup>(2)</sup> )					
Frequency-Data Transfer Mode	fPP	0	-	50	MHz
Frequency-Identification Mode	fOD	0	-	400	kHz
Clock Low Time	tWL	7	-	-	ns
Clock High Time	tWH	7	-	-	ns
Clock Rise Time	tTLH	-	-	3	ns
Clock Fall Time	tTHL	-	-	3	ns
Inputs: CMD, DAT (referenced to CLK)					
Input Setup Time	tISU	6	-	-	ns
Input Hold Time	tIH	2	-	-	ns
Outputs: CMD, DAT (referenced to CLK)					
Output Delay time-Data Transfer Mode	tODLY	-	-	14	ns
Output Hold time	tOH	2.5	-	-	ns
Total System Capacitance (each line)	CL	-	-	40	pF

(1). Timing is based on  $CL \leq 40pF$  load on CMD and Data.

(2). Min (Vih) =  $0.7 \cdot VDDIO$  and max (Vil) =  $0.2 \cdot VDDIO$ .

### 9.3. Bluetooth UART Timing (Default Mode)

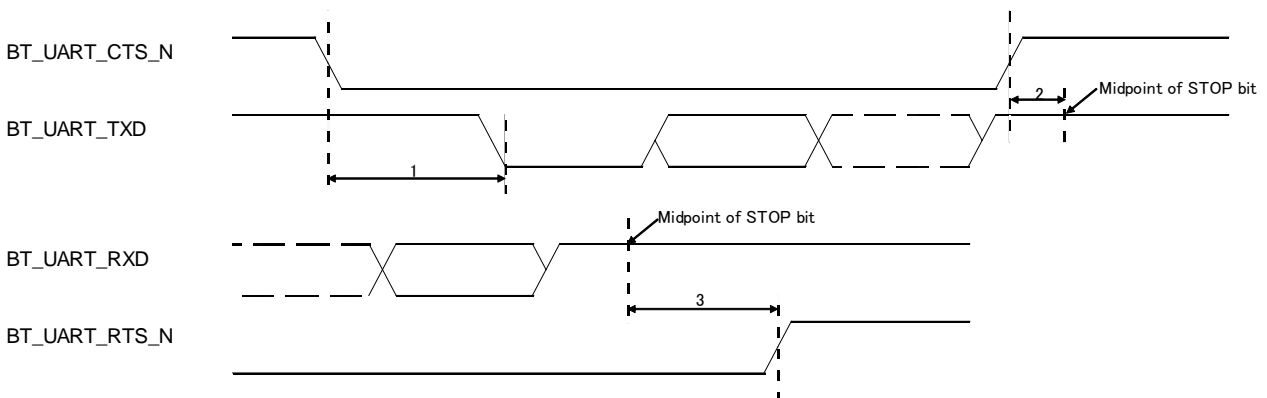

Reference	Description	Min	Typ	Max	Unit
1	Delay time, UART_CTS_N low to UART_TXD valid	-	-	1.5	Bit periods
2	Setup time, UART_CTS_N high before midpoint of stop bit	-	-	0.5	Bit periods
3	Delay time, midpoint of stop bit to UART_RTS_N high	-	-	0.5	Bit periods

### 9.4. PCM Timing Short Frame Sync, Master Mode

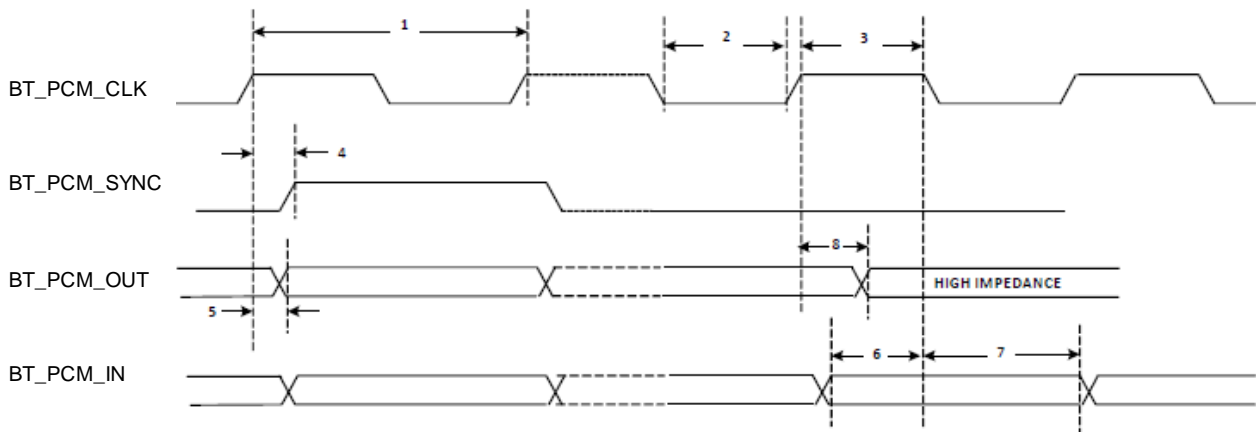

Reference	Description	Min	Typ	Max	Unit
1	PCM bit clock frequency	-	-	12	MHz
2	PCM bit clock low	41	-	-	ns
3	PCM bit clock high	41	-	-	ns
4	PCM_SYNC delay	0	-	25	ns
5	PCM_OUT delay	0	-	25	ns
6	PCM_IN setup	8	-	-	ns
7	PCM_IN hold	8	-	-	ns
8	Delay from rising edge of PCM_CLK during last bit period to PCM_OUT becoming high impedance	0	-	25	ns

### 9.5. PCM Timing Short Frame Sync, Slave Mode

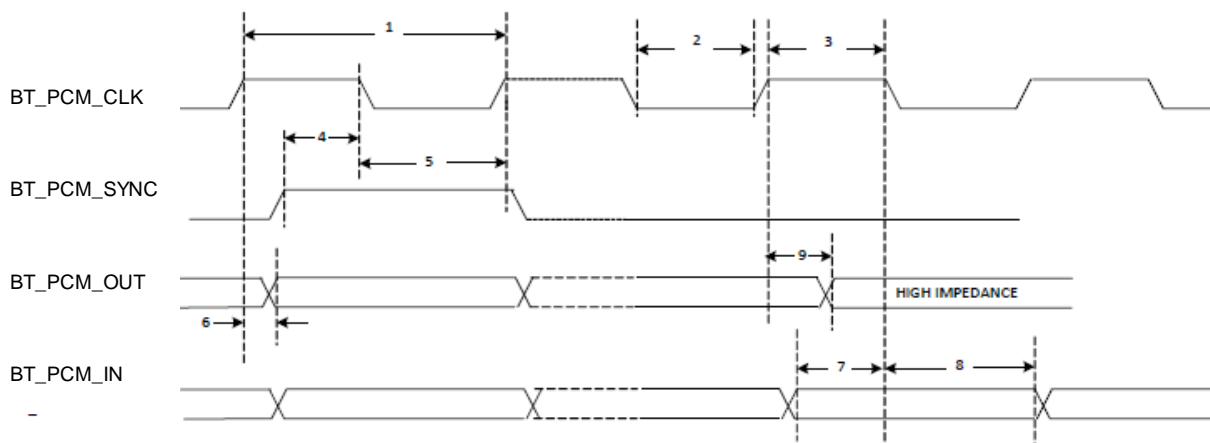

Reference	Description	Min	Typ	Max	Unit
1	PCM bit clock frequency	-	-	12	MHz
2	PCM bit clock Low	41	-	-	ns
3	PCM bit clock High	41	-	-	ns
4	PCM_SYNC setup	8	-	-	ns
5	PCM_SYNC hold	8	-	-	ns
6	PCM_OUT delay	0	-	25	ns
7	PCM_IN setup	8	-	-	ns
8	PCM_IN hold	8	-	-	ns
9	Delay from rising edge of PCM_CLK during last bit period to PCM_OUT becoming high impedance	0	-	25	ns

### 9.6. PCM Timing Long Frame Sync, Master Mode

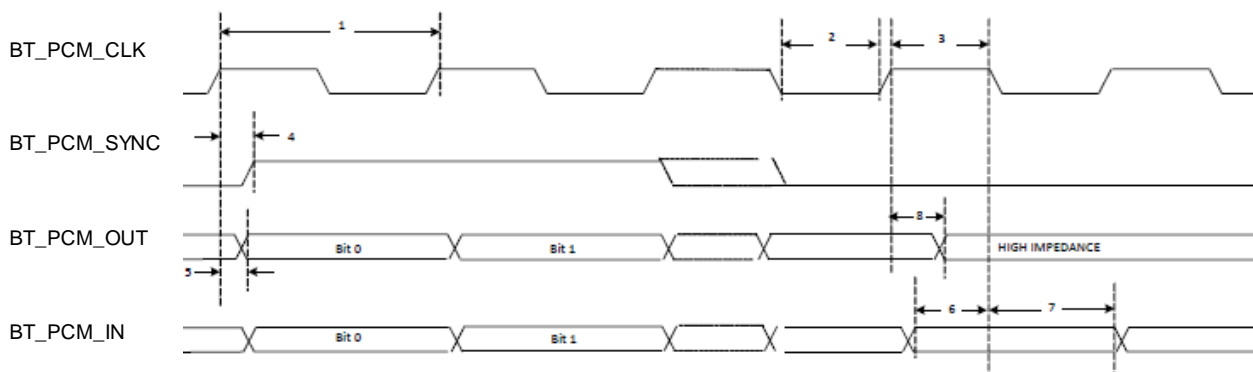

Reference	Description	Min	Typ	Max	Unit
1	PCM bit clock frequency	-	-	12	MHz
2	PCM bit clock low	41	-	-	ns
3	PCM bit clock high	41	-	-	ns
4	PCM_SYNC delay	0	-	25	ns
5	PCM_OUT delay	0	-	25	ns
6	PCM_IN setup	8	-	-	ns
7	PCM_IN hold	8	-	-	ns
8	Delay from rising edge of PCM_CLK during last bit period to PCM_OUT becoming high impedance	0	-	25	ns

### 9.7. PCM Timing Long Frame Sync, Slave Mode

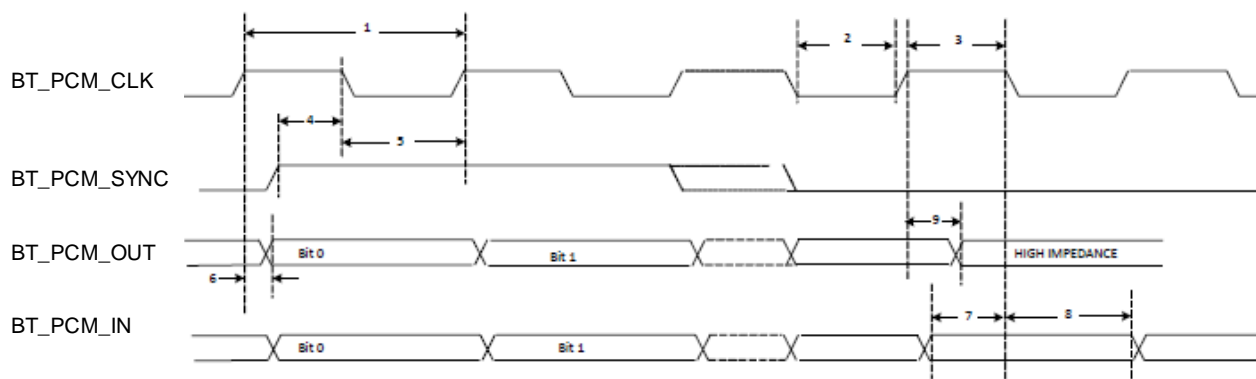

Reference	Description	Min	Typ	Max	Unit
1	PCM bit clock frequency	-	-	12	MHz
2	PCM bit clock low	41	-	-	ns
3	PCM bit clock high	41	-	-	ns
4	PCM_SYNC setup	8	-	-	ns
5	PCM_SYNC hold	8	-	-	ns
6	PCM_OUT delay	0	-	25	ns
7	PCM_IN setup	8	-	-	ns
8	PCM_IN hold	8	-	-	ns
9	Delay from rising edge of PCM_CLK during last bit period to PCM_OUT becoming high impedance	0	-	25	ns



## 10. DC/RF Characteristics

### 10.1. DC/RF Characteristics for IEEE802.11b

Specification	IEEE802.11b
Mode	DSSS / CCK
Frequency	2400 - 2483.5MHz
Data rate	1, 2, 5.5, 11Mbps

Conditions : 25deg.C, VBAT=3.6V, VDDIO= 3.3V, Output power setting=17dBm, 11Mbps mode

Items	Contents			
	min.	typ.	max.	unit
- DC Characteristics -				
DC current				
1) Tx mode (1024byte, 20usec interval)		320	370	mA
2) Rx mode		47	60	mA
- Tx Characteristics -	min.	typ.	max.	unit
Output Power (tolerance)	15	17	19	dBm
Spectrum Mask				
1) 1st side lobes	-	-43	-30	dBr
2) 2nd side lobes	-	-54	-50	dBr
Power-on and Power-down ramp	-		2.0	μsec
RF Carrier Suppression	15		-	dB
Modulation Accuracy (EVM)	-	15	35	%
Outband Spurious Emissions				
1) 30MHz to 1GHz (BW=100kHz)	-	-	-36	dBm
2) 1GHz to 12.75GHz (BW=100kHz)	-	-	-30	dBm
3) 1.8GHz to 1.9GHz (BW=100kHz)	-	-	-47	dBm
4) 5.15GHz to 5.3GHz (BW=100kHz)	-	-	-47	dBm
- Rx Characteristics -	min.	typ.	max.	unit
Minimum Input Level (FER ≤ 8%)	-	-89	-76	dBm
Maximum Input Level (FER ≤ 8%)	-10	-	-	dBm
Adjacent Channel Rejection (FER ≤ 8%)	35	-	-	dB

**10.2. DC/RF Characteristics for IEEE802.11g**

Specification	IEEE802.11g
Mode	OFDM
Frequency	2400 - 2483.5MHz
Data rate	6, 9, 12, 18, 24, 36, 48, 54Mbps

Conditions : 25deg.C, VBAT=3.6V, VDDIO= 3.3V, Output power setting=13dBm, 54Mbps mode

Items	Contents			
- DC Characteristics -	min.	typ.	max.	unit
DC current				
1) Tx mode (1024byte, 20usec interval)		270	310	mA
2) Rx mode		47	60	mA
- Tx Characteristics -	min.	typ.	max.	unit
Output Power (tolerance)	11	13	15	dBm
Spectrum Mask				
1) 9MHz to 11MHz (0dB ~ -20dB)		-33	-20	dBr
2) 11MHz to 20MHz (-20dB ~ -28dB)		-41	-28	dBr
3) 20MHz to 30MHz (-28dB ~ -40dB)		-53	-40	dBr
4) 30MHz to 33MHz (-40dB)		-53	-40	dBr
Constellation Error (EVM)	-	-30	-25	dB
Outband Spurious Emissions				
1) 30MHz to 1GHz (BW=100kHz)	-	-	-36	dBm
2) 1GHz to 12.75GHz (BW=100kHz)	-	-	-30	dBm
3) 1.8GHz to 1.9GHz (BW=100kHz)	-	-	-47	dBm
4) 5.15GHz to 5.3GHz (BW=100kHz)	-	-	-47	dBm
- Rx Characteristics -	min.	typ.	max.	unit
Minimum Input Level (PER ≤ 10%)	-	-75	-65	dBm
Maximum Input Level (PER ≤ 10%)	-20	-	-	dBm
Adjacent Channel Rejection (PER ≤ 10%)	-1	-	-	dB

### 10.3. DC/RF Characteristics for IEEE802.11n

Specification	IEEE802.11n
Mode	OFDM
Frequency	2400 - 2483.5MHz
Data rate	6.5, 13, 19.5, 26, 39, 52, 58.5, 65Mbps

Conditions : 25deg.C, VBAT=3.6V, VDDIO= 3.3V, Output power setting=12dBm, 65Mbps mode

Items	Contents			
	min.	typ.	max.	unit
- DC Characteristics -				
DC current				
1) Tx mode (1024byte, 20usec interval)		260	300	mA
2) Rx mode		47	60	mA
- Tx Characteristics -				
	min.	typ.	max.	unit
Output Power (tolerance)	10	12	14	dBm
Spectrum Mask				
1) 9MHz to 11MHz (0dB ~ -20dB)		-33	-20	dBr
2) 11MHz to 20MHz (-20dB ~ -28dB)		-41	-28	dBr
3) 20MHz to 30MHz (-28dB ~ -45dB)		-53	-45	dBr
4) 30MHz to 33MHz (-45dB)		-53	-45	dBr
Constellation Error (EVM)	-	-31	-27	dB
Outband Spurious Emissions				
1) 30MHz to 1GHz	-	-	-36	dBm
2) 1GHz to 12.75GHz	-	-	-30	dBm
3) 1.8GHz to 1.9GHz	-	-	-47	dBm
4) 5.15GHz to 5.3GHz	-	-	-47	dBm
- Rx Characteristics -				
	min.	typ.	max.	unit
Minimum Input Level (PER <sub>≤</sub> 10%)	-	-73	-64	dBm
Maximum Input Level (PER <sub>≤</sub> 10%)	-20	-	-	dBm
Adjacent Channel Rejection (PER <sub>≤</sub> 10%)	-2	-	-	dB



#### 10.4. DC/RF Characteristics for Bluetooth

Normal conditions : 25deg.C, VBAT = 3.6V, VDDIO = 3.3V

Items	Contents			
Bluetooth specification (power class)	Version 2.1 + EDR (Class1)			
Channel frequency (spacing)	2402 to 2480 MHz (1MHz)			
<b>Current Consumption</b>	<b>Min.</b>	<b>Typ.</b>	<b>Max.</b>	<b>unit</b>
(a) Tx=Rx=DH5 (fully occupied)	-	28	60	mA
(b) Tx=Rx=2DH5 (fully occupied)	-	25	50	mA
(c) Tx=Rx=3DH5 (fully occupied)	-	25	50	mA
<b>Transmitter</b>	<b>Min.</b>	<b>Typ.</b>	<b>Max.</b>	<b>Unit</b>
Output Power	6	10	14	dBm
Frequency range	2400	-	2483.5	MHz
20dB bandwidth	-	-	1	MHz
Adjacent Channel Power <sup>*1</sup>				
(a) [M-N] =2	-	-	-20	dBm
(b) [M-N] ≥3	-	-	-40	dBm
Modulation characteristics				
(a) Modulation Δf1avg	140	-	175	kHz
(b) Modulation Δf2max	115	-	-	kHz
(c) Modulation Δf2avg / Δf1avg	0.8	-	-	
Carrier Frequency Drift				
(a) 1slot	-25	-	+25	kHz
(b) 3slot / 5slot	-40	-	+40	kHz
(c) Maximum drift rate	-	-	20	kHz/50us
EDR Relative Power	-4	-	+1	dB
EDR Carrier Frequency Stability and Modulation Accuracy				
(a) ωi	-75	-	+75	kHz
(b) ωi+ωo	-75	-	+75	kHz
(c) ωo	-10	-	+10	kHz
(d) RMS DEVM (DQPSK)	-	-	20	%
(e) Peak DEVM (DQPSK)	-	-	35	%
(f) 99% DEVM (DQPSK)	-	-	30	%
(g) RMS DEVM (8DPSK)	-	-	13	%
(h) Peak DEVM (8DPSK)	-	-	25	%
(i) 99% DEVM (8DPSK)	-	-	20	%
Out-of-Band Spurious Emissions				
(a) 30-1000MHz	-	-	-36	dBm
(b) 1000-12750MHz	-	-	-30	dBm
(c) 1800-1900MHz	-	-	-47	dBm
(d) 5150-5300MHz	-	-	-47	dBm
<b>Receiver</b>	<b>Min.</b>	<b>Typ.</b>	<b>Max.</b>	<b>unit</b>
Sensitivity (BER≤0.1%)	-	-91	-80	dBm
C/I Performance (BER≤0.1%) <sup>*2</sup>				
(a) co-channel	-	-	11	dB
(b) 1MHz	-	-	0	dB
(c) 2MHz	-	-	-30	dB
(d) 3MHz	-	-	-40	dB
(e) image (+4MHz)	-	-	-9	dB
(f) image +/- 1MHz	-	-	-20	dB
Maximum Input Level (PER≤0.1%)	-20	-	-	dBm
EDR Sensitivity (PER≤0.007%)				
(a) 8DPSK	-	-88	-77	dBm

\*1: Up to three spurious responses within Bluetooth limits are allowed.

\*2: Up to five spurious responses within Bluetooth limits are allowed.



### 10.5. DC/RF Characteristics for Bluetooth(LE)

Conditions : 25deg.C, VBAT=3.6V, VDDIO= 3.3V

Items	Contents			
Bluetooth specification (power class)	Version 4.1(LE)			
Channel frequency (spacing)	2402 to 2480 MHz (2MHz)			
Number of RF Channel	40			
Item / Condition	Min.	Typ.	Max.	Unit
Center Frequency	2402	-	2480	MHz
Channel Spacing	-	2	-	MHz
Number of RF channel	-	40	-	-
Output power	-	-	10	dBm
Modulation Characteristics				
1) $\Delta f_{1_{avg}}$	225	-	275	kHz
2) $\Delta f_{2_{max}}$ (at 99.9%)	185	-	-	kHz
3) $\Delta f_{2_{avg}} / \Delta f_{1_{avg}}$	0.8	-	-	-
Carrier frequency offset and drift				
1) Frequency offset	-	-	150	kHz
2) Frequency drift	-	-	50	kHz
3) Drift rate	-	-	20	kHz
Receiver sensitivity (PER < 30.8%)	-	-95	-70	dBm
Maximum input signal level (PER < 30.8%)	-10	-	-	dBm
PER Report Integrity (-30dBm input)	50	-	65.4	%

**11. Land pattern**

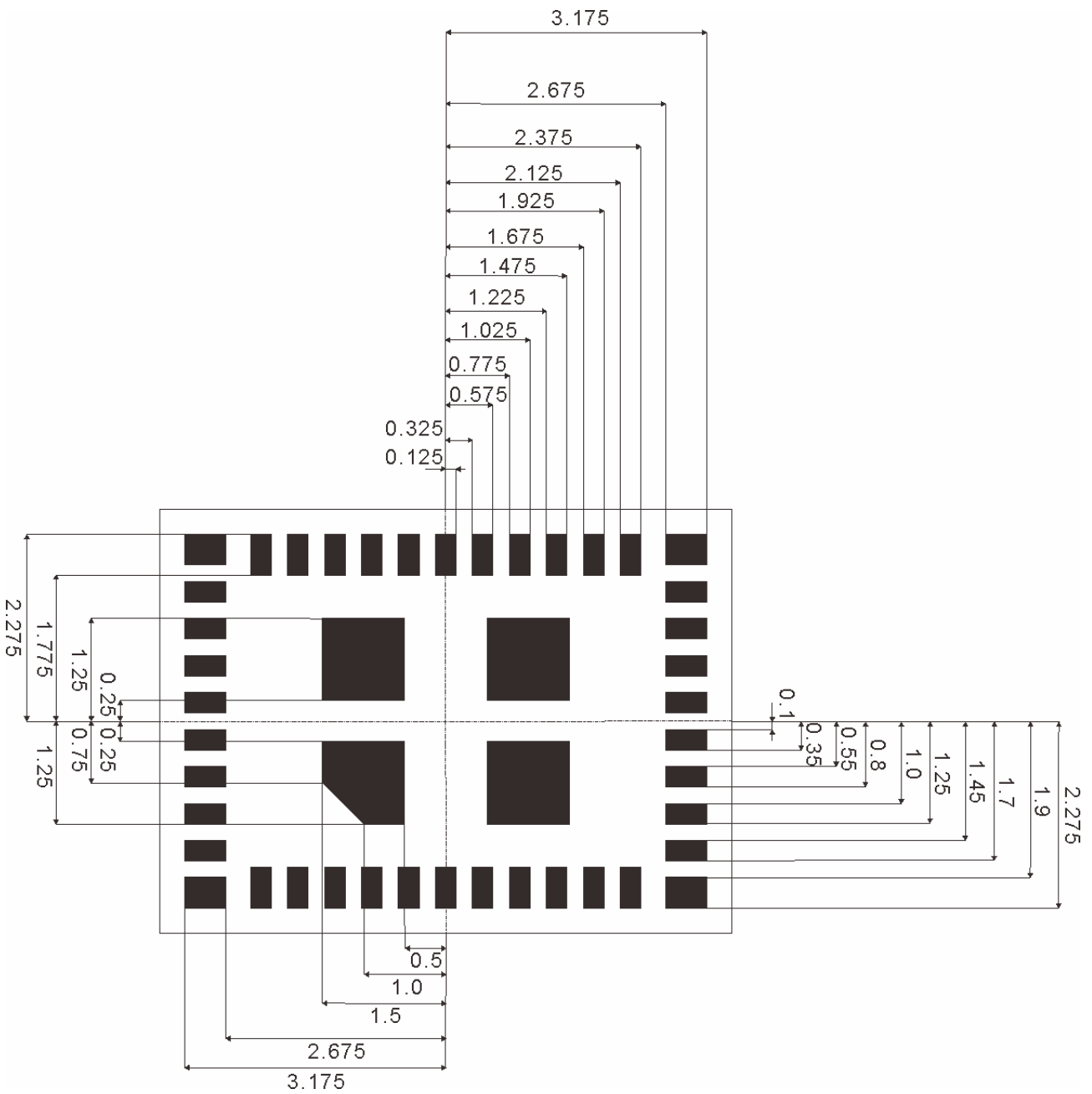

Top View. Unit : mm

**12. Reference Circuit**

(\*1) LQM18PN2R2MGH recommended

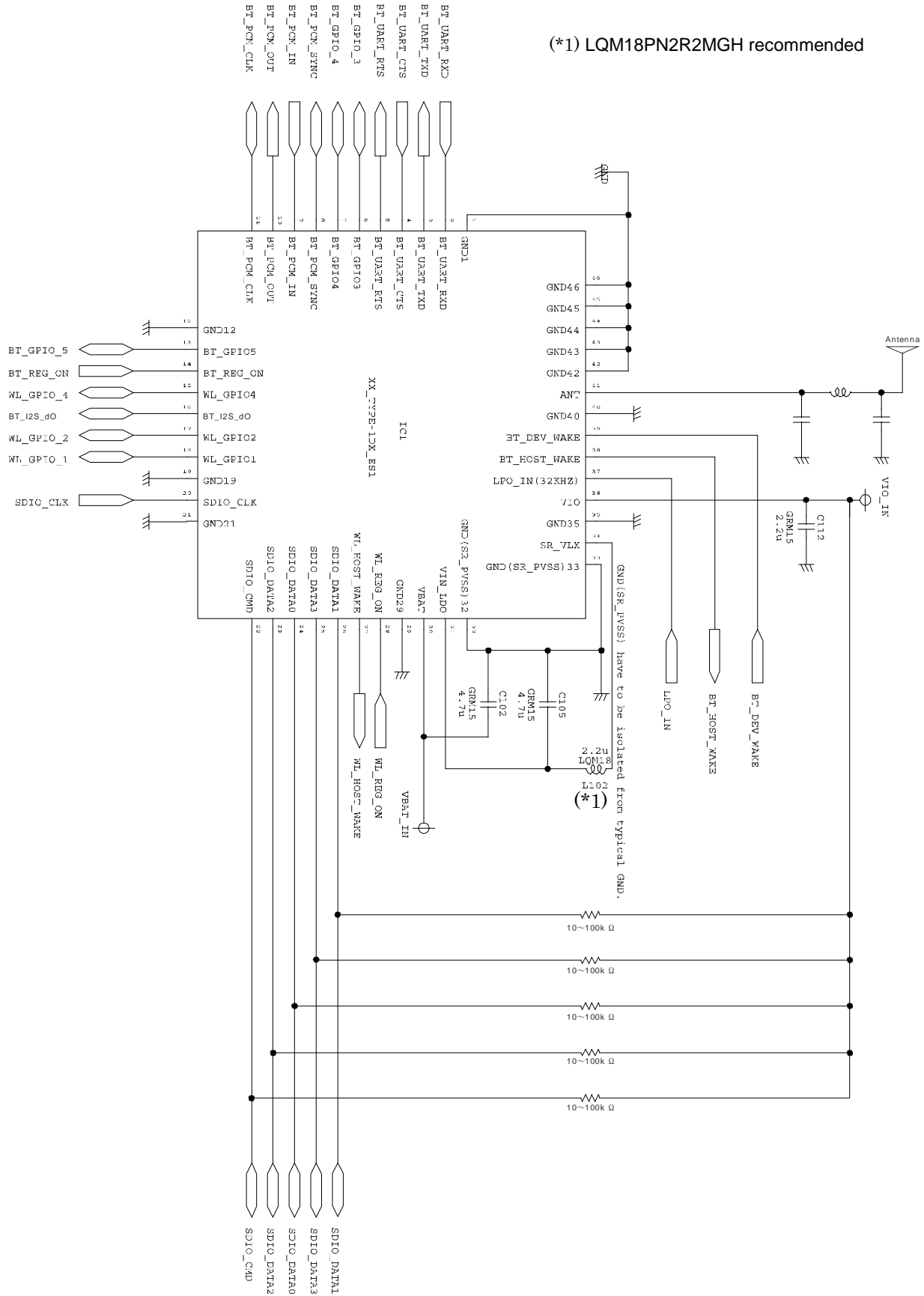

### 13. Tape and Reel Packing

#### (1) Dimensions of Tape (Plastic tape)

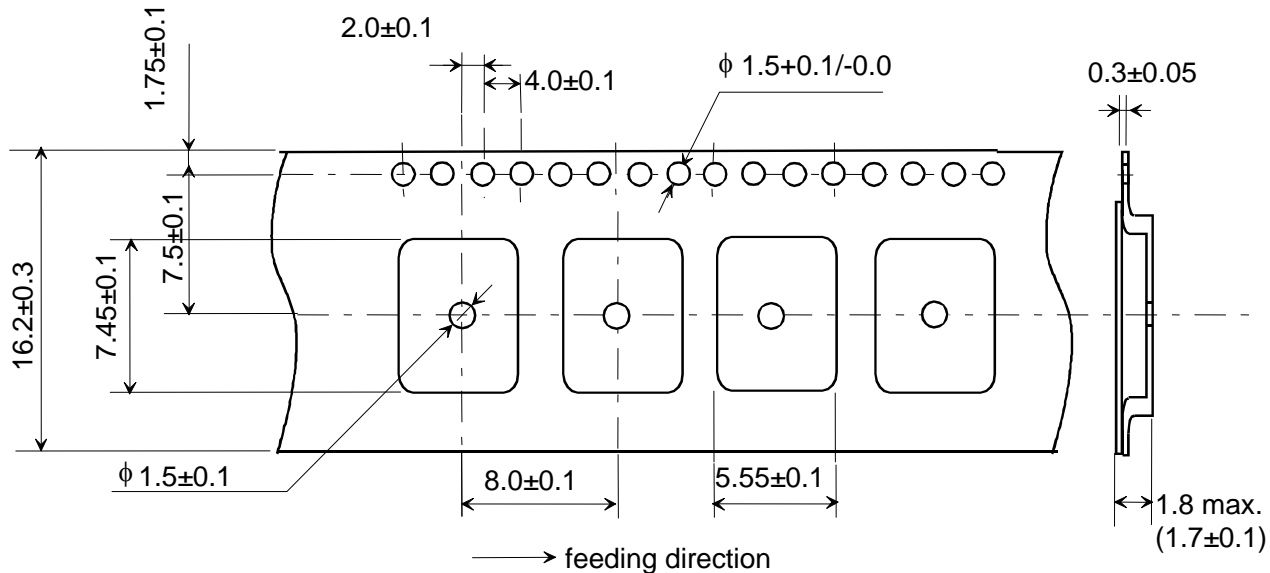

- 1) The corner and ridge radiuses (R) of inside cavity are 0.3mm max.
- 2) Cumulative tolerance of 10 pitches of the sprocket hole is  $\pm 0.2$ mm
- 3) Measuring of cavity positioning is based on cavity center in accordance with JIS/IES standard.

#### (2) Dimensions of Reel

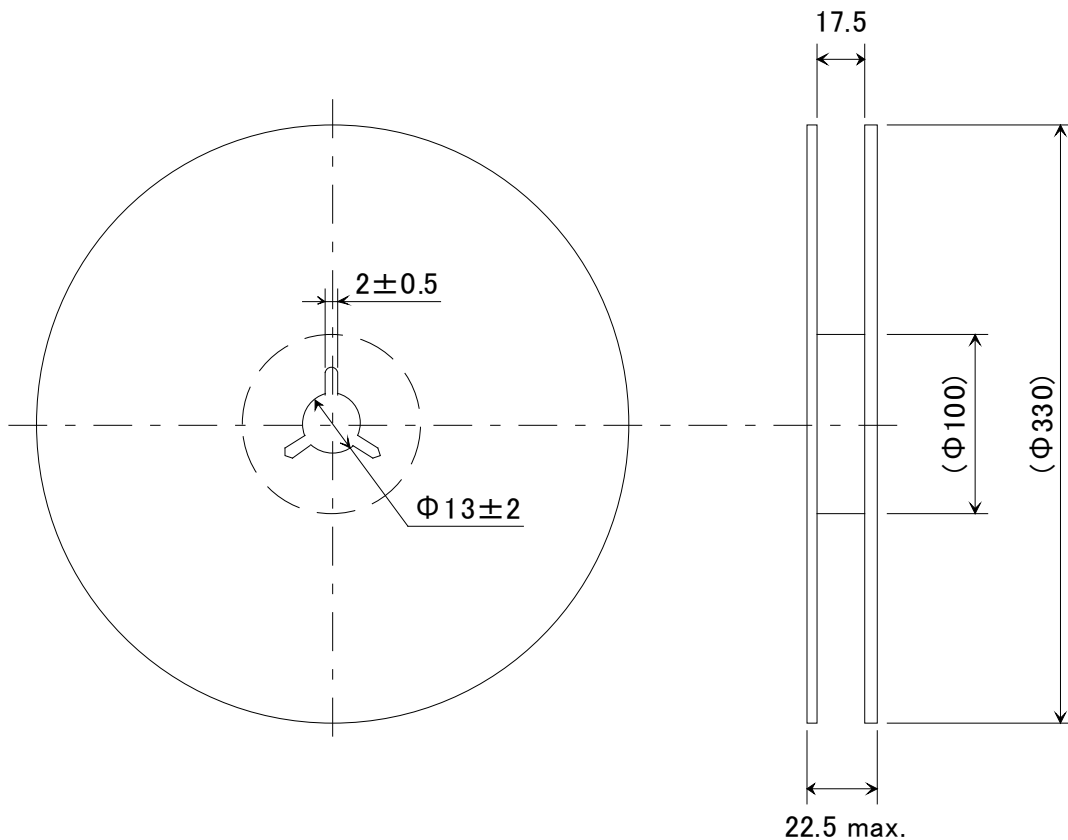

(unit : mm)

(3) Taping Diagrams

[1] Feeding Hole : As specified in (1)

[2] Hole for chip : As specified in (1)

[3] Cover tape : 62μm in thickness

[4] Base tape : As specified in (1)

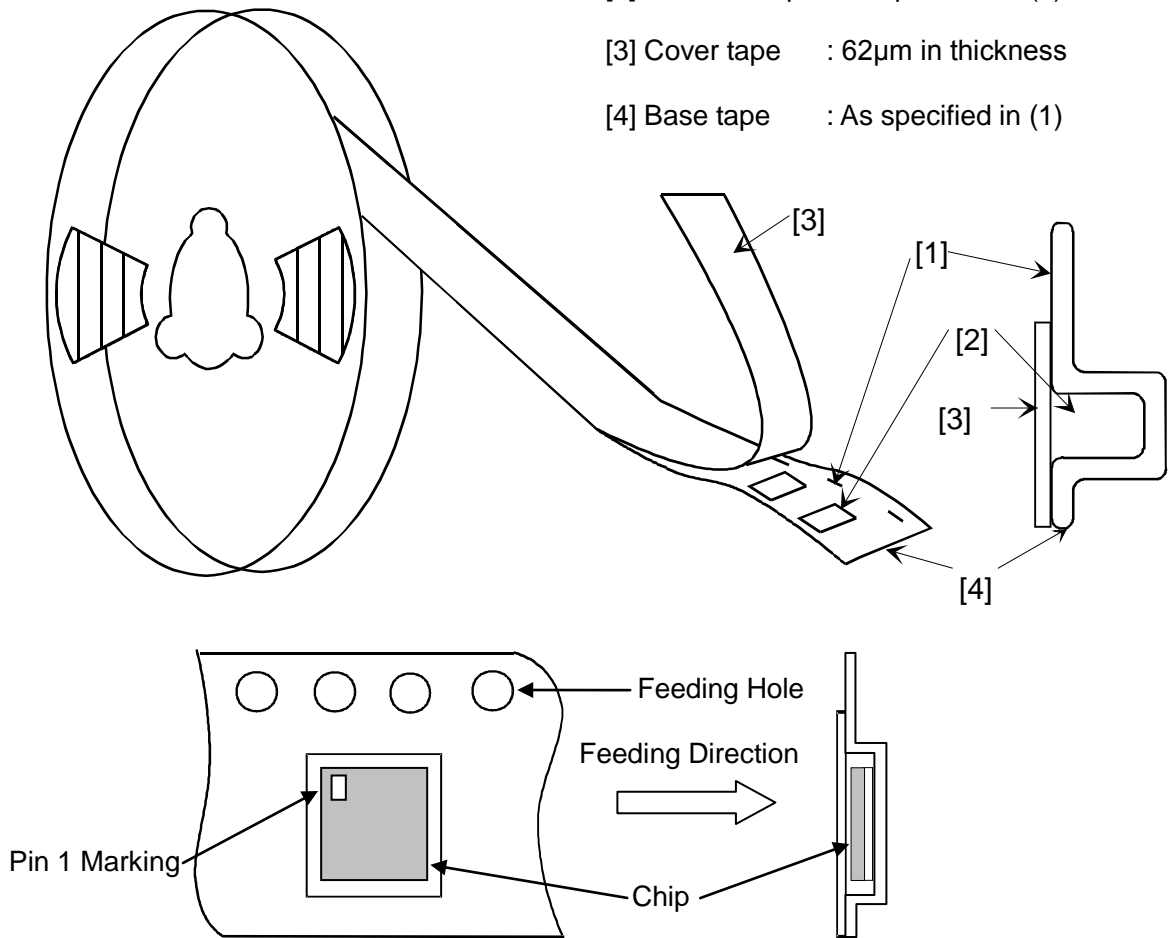

(4) Leader and Tail tape

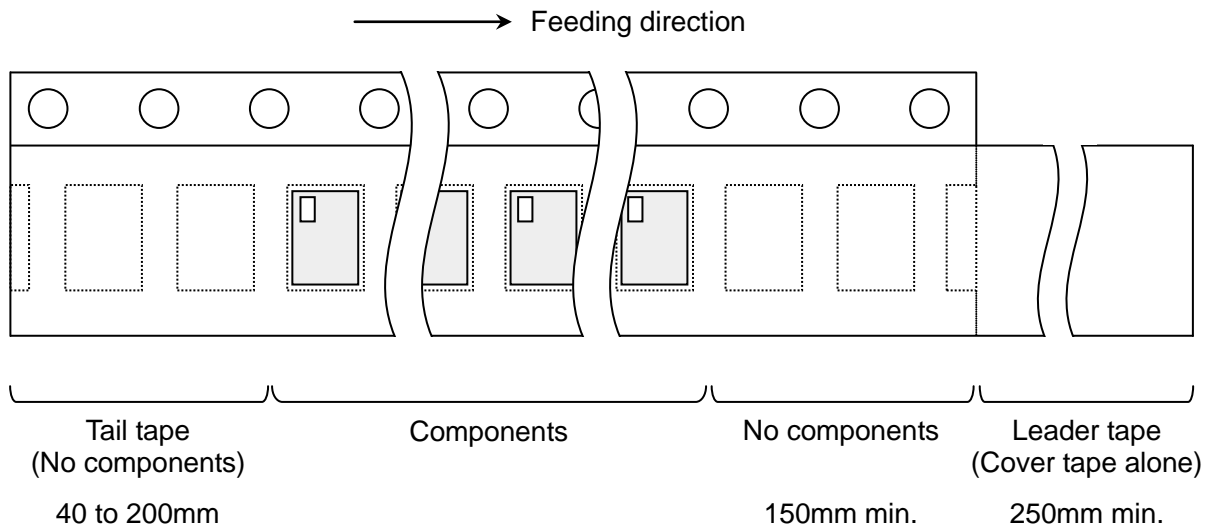

- (5) The tape for chips are wound clockwise, the feeding holes to the right side as the tape is pulled toward the user.
- (6) The cover tape and base tape are not adhered at no components area for 250mm min.
- (7) Tear off strength against pulling of cover tape : 5N min.
- (8) Packaging unit : 1000pcs./ reel
- (9) material : Base tape : Plastic  
Real : Plastic  
Cover tape, cavity tape and reel are made the anti-static processing.
- (10) Peeling of force : 1.1N max. in the direction of peeling as shown below.

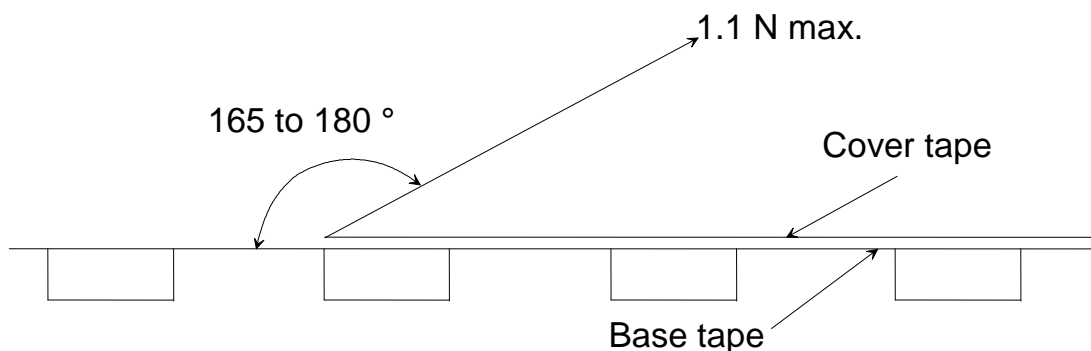

- (11) Packaging (Humidity proof Packing)

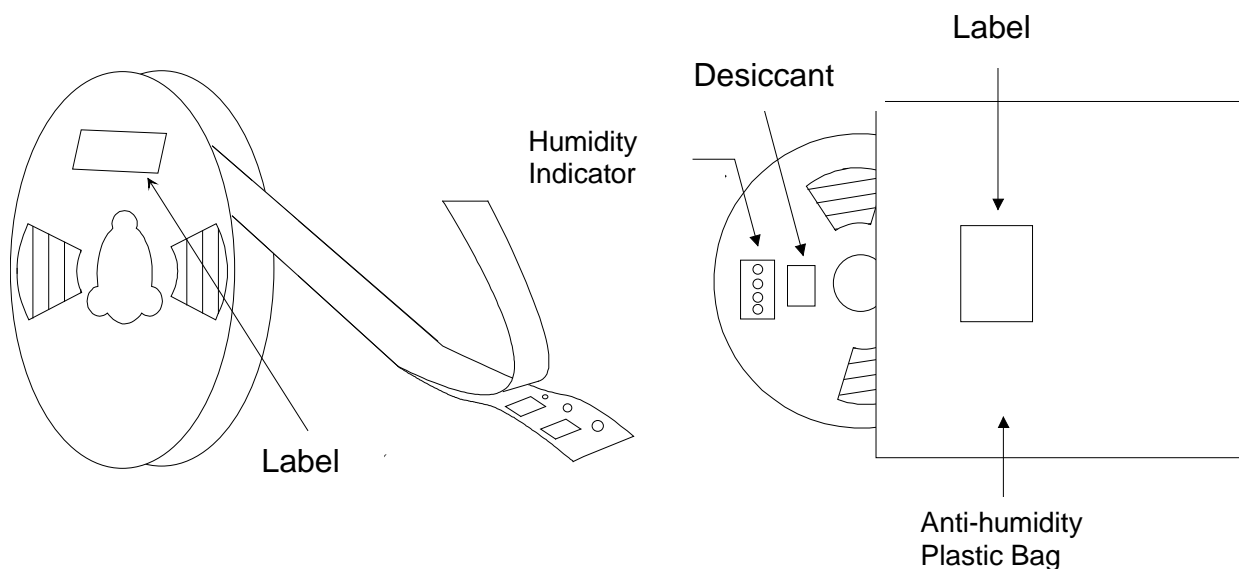

Tape and reel must be sealed with the anti-humidity plastic bag. The bag contains the desiccant and the humidity indicator.



## 14. **NOTICE**

### 14.1. **Storage Conditions:**

Please use this product within 6month after receipt.

- The product shall be stored without opening the packing under the ambient temperature from 5 to 35deg.C and humidity from 20 to 70%RH.

(Packing materials, in particular, may be deformed at the temperature over 40deg.C.)

- The product left more than 6months after reception, it needs to be confirmed the solderbility before used.

- The product shall be stored in non corrosive gas (Cl<sub>2</sub>, NH<sub>3</sub>, SO<sub>2</sub>, NO<sub>x</sub>, etc.).

- Any excess mechanical shock including, but not limited to, sticking the packing materials by sharp object and dropping the product, shall not be applied in order not to damage the packing materials.

This product is applicable to MSL3 (Based on JEDEC Standard J-STD-020)

- After the packing opened, the product shall be stored at  $\leq 30$ deg.C /  $\leq 60$ %RH and the product shall be used within 168hours.

- When the color of the indicator in the packing changed, the product shall be baked before soldering.

Baking condition: 125+5/-0deg.C, 24hours, 1time

The products shall be baked on the heat-resistant tray because the material (Base Tape, Reel Tape and Cover Tape) are not heat-resistant.

### 14.2. **Handling Conditions:**

Be careful in handling or transporting products because excessive stress or mechanical shock may break products.

Handle with care if products may have cracks or damages on their terminals, the characteristics of products may change. Do not touch products with bear hands that may result in poor solder ability and destroy by static electrical charge.

### 14.3. **Standard PCB Design (Land Pattern and Dimensions):**

All the ground terminals should be connected to the ground patterns. Furthermore, the ground pattern should be provided between IN and OUT terminals. Please refer to the specifications for the standard land dimensions.

The recommended land pattern and dimensions is as Murata's standard. The characteristics of products may vary depending on the pattern drawing method, grounding method, land dimensions, land forming method of the NC terminals and the PCB material and thickness. Therefore, be sure to verify the characteristics in the actual set. When using non-standard lands, contact Murata beforehand.

### 14.4. **Notice for Chip Placer:**

When placing products on the PCB, products may be stressed and broken by uneven forces from a worn-out chucking locating claw or a suction nozzle. To prevent products from damages, be sure to follow the specifications for the maintenance of the chip placer being used. For the positioning of products on the PCB, be aware that mechanical chucking may damage products.

### 14.5. Soldering Conditions:

The recommendation conditions of soldering are as in the following figure. When products are immersed in solvent after mounting, pay special attention to maintain the temperature difference within 100 °C. Soldering must be carried out by the above mentioned conditions to prevent products from damage. Set up the highest temperature of reflow within 260 °C. Contact Murata before use if concerning other soldering conditions.

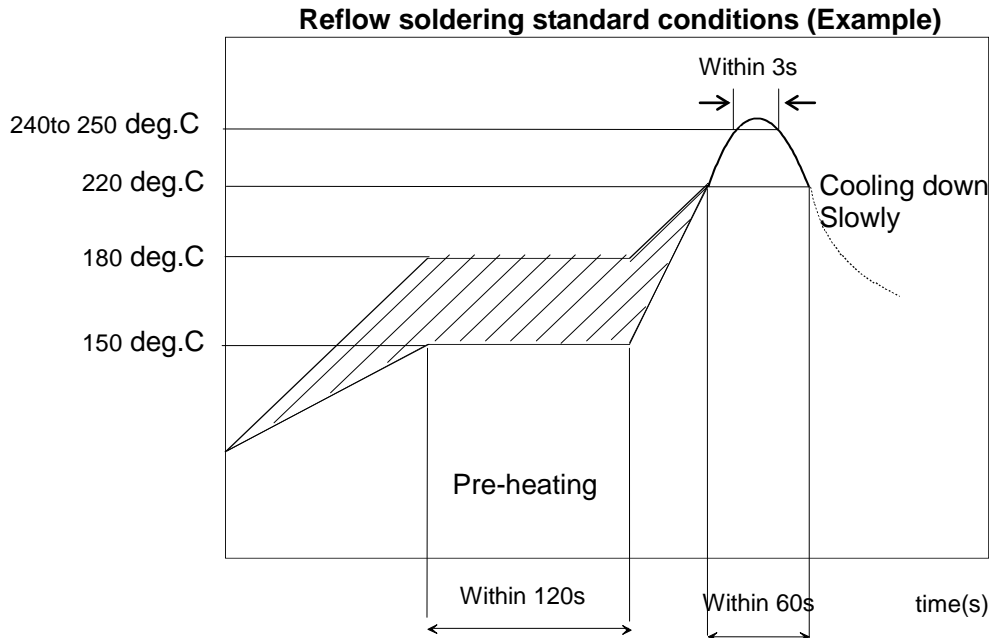

Please use the reflow within 2 times.  
Use rosin type flux or weakly active flux with a chlorine content of 0.2 wt % or less.

### 14.6. Cleaning:

Since this Product is Moisture Sensitive, any cleaning is not permitted.

### 14.7. Operational Environment Conditions:

Products are designed to work for electronic products under normal environmental conditions (ambient temperature, humidity and pressure). Therefore, products have no problems to be used under the similar conditions to the above-mentioned. However, if products are used under the following circumstances, it may damage products and leakage of electricity and abnormal temperature may occur.

- In an atmosphere containing corrosive gas (Cl<sub>2</sub>, NH<sub>3</sub>, SO<sub>x</sub>, NO<sub>x</sub>, etc.).
- In an atmosphere containing combustible and volatile gases.
- Dusty place.
- Direct sunlight place.
- Water splashing place.
- Humid place where water condenses.
- Freezing place.

If there are possibilities for products to be used under the preceding clause, consult with Murata before actual use.

As it might be a cause of degradation or destruction to apply static electricity to products, do not apply static electricity or excessive voltage while assembling and measuring.

#### **14.8. Input Power Capacity:**

Products shall be used in the input power capacity as specified in this specifications.  
Inform Murata beforehand, in case that the components are used beyond such input power capacity range.



## **15. PRECONDITION TO USE OUR PRODUCTS**

PLEASE READ THIS NOTICE BEFORE USING OUR PRODUCTS.

Please make sure that your product has been evaluated and confirmed from the aspect of the fitness for the specifications of our product when our product is mounted to your product.

All the items and parameters in this product specification/datasheet/catalog have been prescribed on the premise that our product is used for the purpose, under the condition and in the environment specified in this specification. You are requested not to use our product deviating from the condition and the environment specified in this specification.

Please note that the only warranty that we provide regarding the products is its conformance to the specifications provided herein. Accordingly, we shall not be responsible for any defects in products or equipment incorporating such products, which are caused under the conditions other than those specified in this specification.

WE HEREBY DISCLAIMS ALL OTHER WARRANTIES REGARDING THE PRODUCTS, EXPRESS OR IMPLIED, INCLUDING WITHOUT LIMITATION ANY WARRANTY OF FITNESS FOR A PARTICULAR PURPOSE, THAT THEY ARE DEFECT-FREE, OR AGAINST INFRINGEMENT OF INTELLECTUAL PROPERTY RIGHTS.

The product shall not be used in any application listed below which requires especially high reliability for the prevention of such defect as may directly cause damage to the third party's life, body or property. You acknowledge and agree that, if you use our products in such applications, we will not be responsible for any failure to meet such requirements. Furthermore, YOU AGREE TO INDEMNIFY AND DEFEND US AND OUR AFFILIATES AGAINST ALL CLAIMS, DAMAGES, COSTS, AND EXPENSES THAT MAY BE INCURRED, INCLUDING WITHOUT LIMITATION, ATTORNEY FEES AND COSTS, DUE TO THE USE OF OUR PRODUCTS IN SUCH APPLICATIONS.

- Aircraft equipment.                      - Aerospace equipment                      - Undersea equipment.
- Power plant control equipment      - Medical equipment.
- Transportation equipment (vehicles, trains, ships, elevator, etc.).
- Traffic signal equipment.              - Disaster prevention / crime prevention equipment.
- Burning / explosion control equipment
- Application of similar complexity and/ or reliability requirements to the applications listed in the above.

We expressly prohibit you from analyzing, breaking, reverse-engineering, remodeling altering, and reproducing our product. Our product cannot be used for the product which is prohibited from being manufactured, used, and sold by the regulations and laws in the world.

We do not warrant or represent that any license, either express or implied, is granted under any our patent right, copyright, mask work right, or our other intellectual property right relating to any combination, machine, or process in which our products or services are used. Information provided by us regarding third-party products or services does not constitute a license from us to use such products or services or a warranty or endorsement thereof. Use of such information may require a license from a third party under the patents or other intellectual property of the third party, or a license from us under our patents or other intellectual property.

Please do not use our products, our technical information and other data provided by us for the purpose of developing of mass-destruction weapons and the purpose of military use.

Moreover, you must comply with "foreign exchange and foreign trade law", the "U.S. export administration regulations", etc.

Please note that we may discontinue the manufacture of our products, due to reasons such as end of supply of materials and/or components from our suppliers.

By signing on specification sheet or approval sheet, you acknowledge that you are the legal representative for your company and that you understand and accept the validity of the contents herein. When you are not able to return the signed version of specification sheet or approval sheet within 30 days from receiving date of specification sheet or approval sheet, it shall be deemed to be your consent on the content of specification sheet or approval sheet. Customer acknowledges that engineering samples may deviate from specifications and may contain defects due to their development status. We reject any liability or product warranty for engineering samples. In particular we disclaim liability for damages caused by

- the use of the engineering sample other than for evaluation purposes, particularly the installation or integration in the product to be sold by you,
- deviation or lapse in function of engineering sample,
- improper use of engineering samples.

We disclaim any liability for consequential and incidental damages.

If you can't agree the above contents, you should inquire our sales.