



# TAOGLAS®



# Datasheet

## LA.02 2.4GHz Embedded Loop Chip Antenna

**Part No:**  
LA.02

### Description:

1dBi 2400MHz to 2500MHz Wi-Fi/Bluetooth/Bluetooth LE/ ZigBee

### Features:

- 8\*2\*2mm Ceramic Antenna
- Surface Mount
- Low Profile
- Peak gain 1dBi
- 50 Ohm Impedance
- Components can be mounted on opposite side of board to the antenna
- RoHS & REACH Compliant

1.	Introduction	3
2.	Specifications	5
3.	Antenna Characteristics	6
4.	Radiation Patterns	8
5.	Mechanical Drawing – Antenna	10
6.	Mechanical Drawing – Evaluation Board	13
7.	Soldering Conditions	14
8.	Packaging	15
9.	Changelog	17

Taoglas makes no warranties based on the accuracy or completeness of the contents of this document and reserves the right to make changes to specifications and product descriptions at any time without notice. Taoglas reserves all rights to this document and the information contained herein. Reproduction, use or disclosure to third parties without express permission is strictly prohibited.



## 1. Introduction



The LA.02 is a 2.4GHz embedded loop chip antenna that has best in class efficiency, 66% on center frequency. It's a miniature SMD ceramic component, designed to be mounted directly on the edge of the main device PCB and is suitable especially for very small space requirements for Bluetooth LE, Wi-Fi, 802.11 applications. The LA.02 uses this main PCB ground plane to increase antenna efficiency, requiring minimum ground-clearance around the antenna. The opposite side of the board on which the antenna is mounted does not need ground-clearance, allowing more space for components or signal routing. This antenna is delivered on tape and reel.

Some frequency offset may happen as is normal with antennas embedded devices, so the antenna can be tuned for different PCB sizes and enclosures by simply changing the value of the matching circuit. Please contact your regional Taoglas sales office for support.

Many module manufacturers specify peak gain limits for any antennas that are to be connected to that module. Those peak gain limits are based on free-space conditions. In practice, the peak gain of an antenna tested in free-space can degrade by at least 1 or 2dBi when put inside a device. So ideally you should go for a slightly higher peak gain antenna than mentioned on the module specification to compensate for this effect, giving you better performance.

Upon testing of any of our antennas with your device and a selection of appropriate layout, integration technique, or cable, Taoglas can make sure any of our antennas' peak gain will be below the peak gain limits. Taoglas can then issue a specification and/or report for the selected antenna in your device that will clearly show it complying with the peak gain limits, so you can be assured you are meeting regulatory requirements for that module.

For example, a module manufacturer may state that the antenna must have less than 2dBi peak gain, but you don't need to select an embedded antenna that has a peak gain of less than 2dBi in free-space. This will give you a less optimized solution. It is better to go for a slightly higher free-space peak gain of 3dBi or more if available. Once that antenna gets integrated into your device, performance will degrade below this 2dBi peak gain due to the effects of GND plane, surrounding components, and device housing. If you want to be absolutely sure, contact Taoglas and we will test. Choosing a Taoglas antenna with a higher peak gain than what is specified by the module manufacturer and enlisting our help will ensure you are getting the best performance possible without exceeding the peak gain limits.

**Applications:**

Telematics devices

Bluetooth LE Wearables

Bluetooth Headsets

Hand-held devices when Bluetooth/Wi-Fi functions are needed, e.g., smart phone.

IEEE802.11 b/g

ZigBee

Wireless PCMCIA cards or USB dongle

## 2. Specifications

Antenna	
Frequency (MHz)	2400-2500 MHz
Efficiency (%)	
80 x 40 mm Ground Plane	66% (Centre Frequency)
Peak Gain (dBi)	
80 x 40 mm Ground Plane	1 dBi (Typ.)
VSWR	2 max (Centre Frequency)
Impedance ( $\Omega$ )	50 $\Omega$
Polarization	Linear
Bandwidth	100MHz min.
Mechanical	
Dimensions (mm)	8.0 x 2.0 x 2.0
Material	Ceramic
Weight (g)	0.11
Environmental	
Temperature Range	-40°C to 85°C
Storage Temperature	-40°C to 105°C
Temperature Coefficient (tf)	0 $\pm$ 20 ppm @-20°C to +80°C
Recommended Reel Storage Condition	5°C to 40°C Relative Humidity 20% to 70%
Moisture Sensitivity Level	3 (168 Hours)

### 3. Antenna Characteristics

#### 3.1 Return Loss

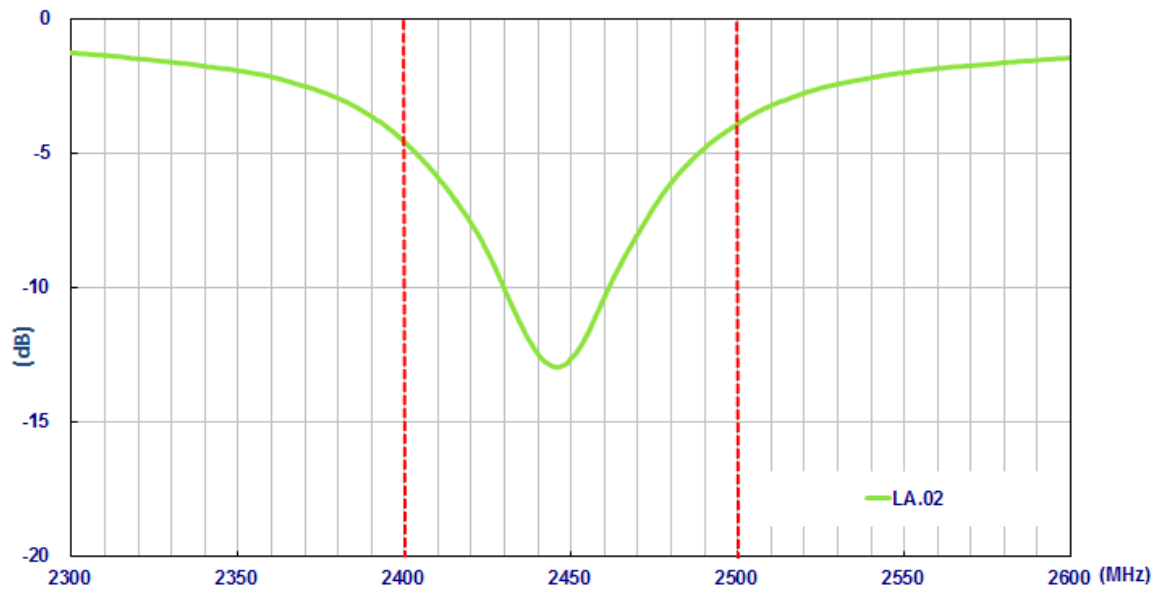

#### 3.2 Efficiency

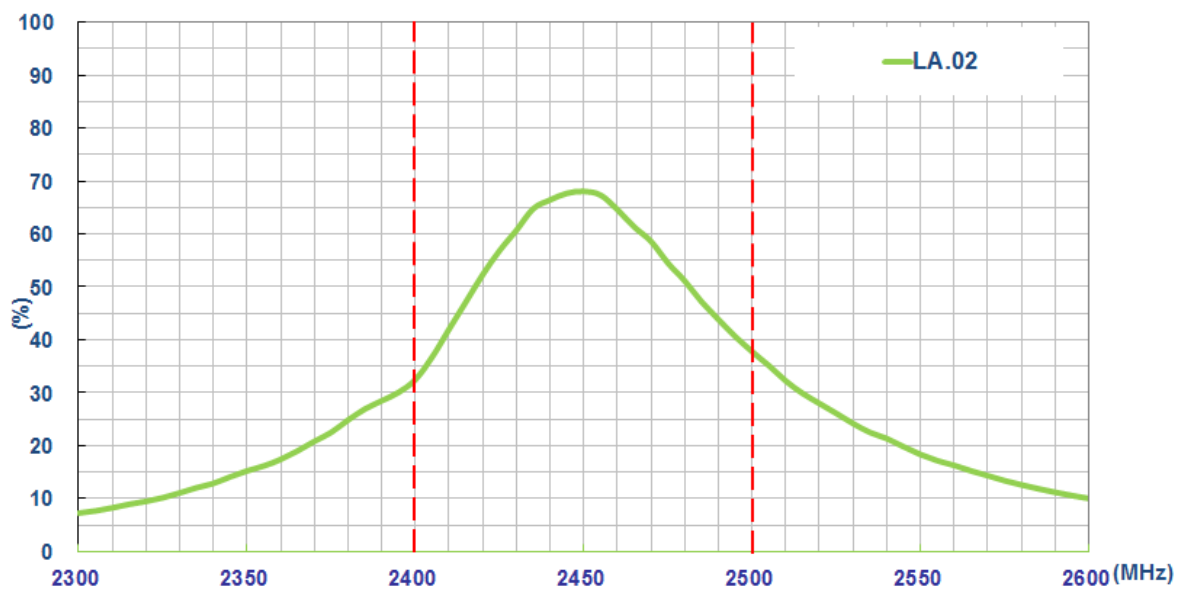

### 3.3 Average Gain

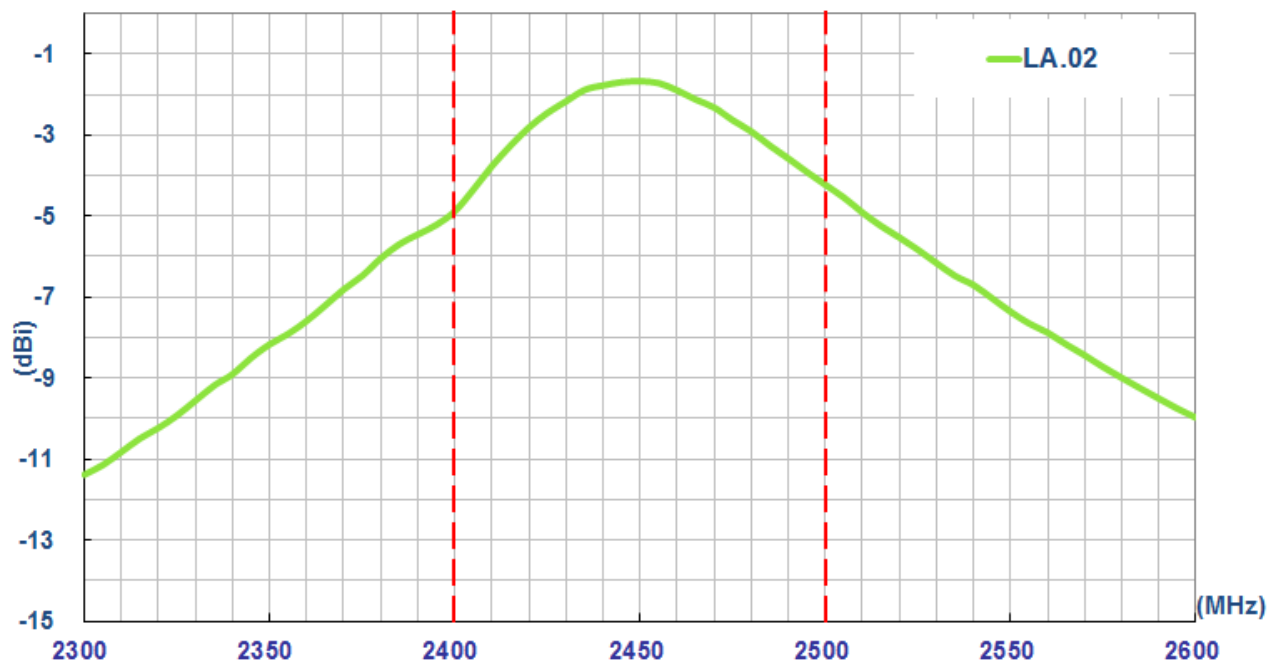

### 3.4 Peak Gain

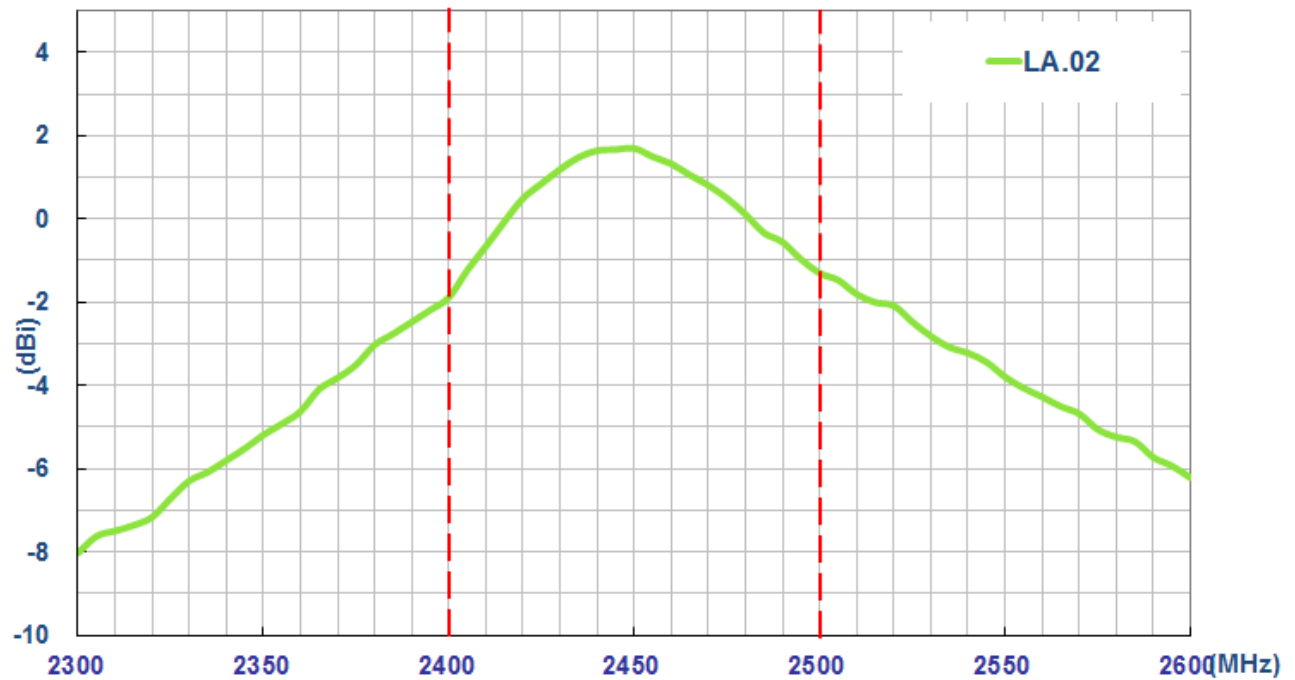

## 4. Radiation Patterns

### 4.1 Test Setup – Antenna on Evaluation Board

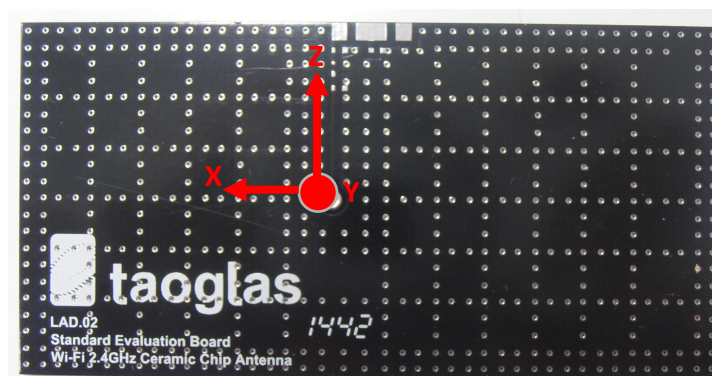
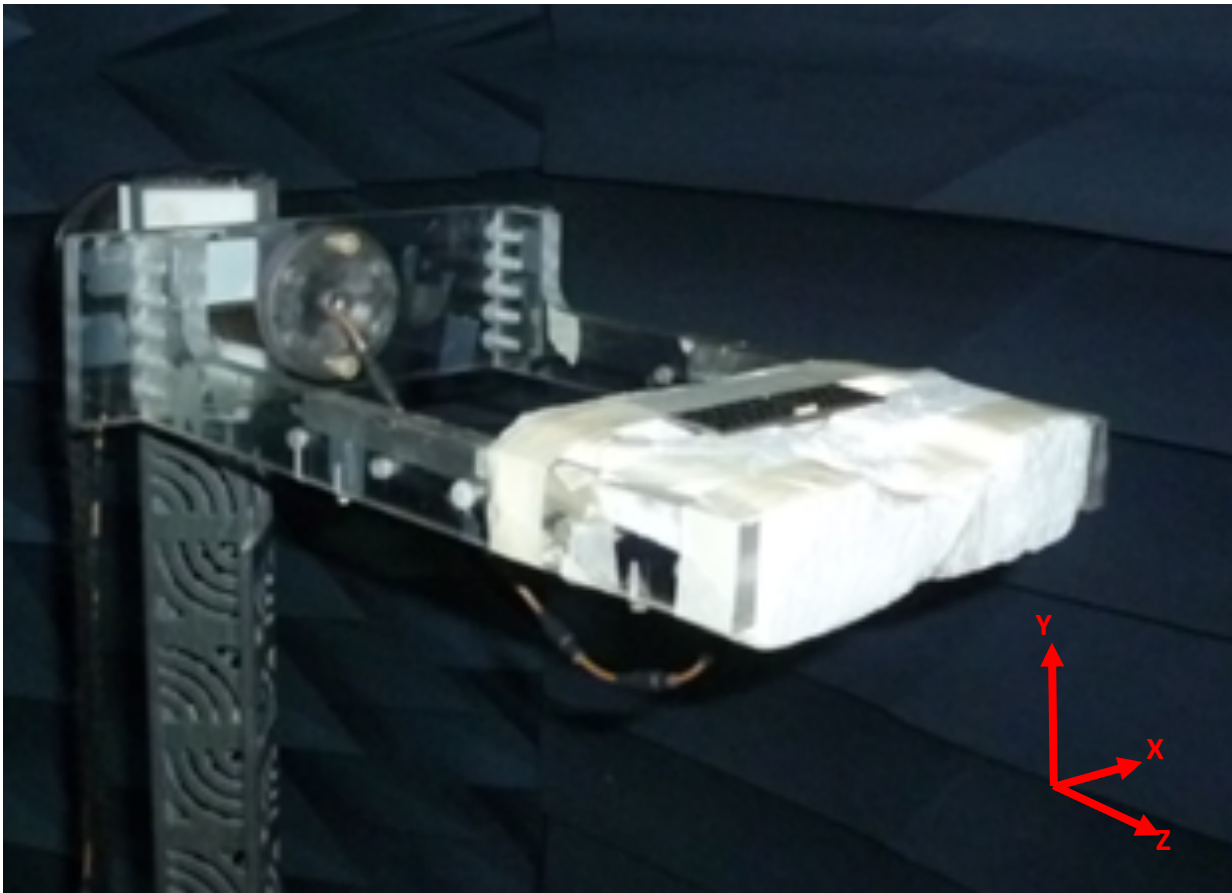

## 4.2 2D Radiation Pattern

2400-2500 MHz

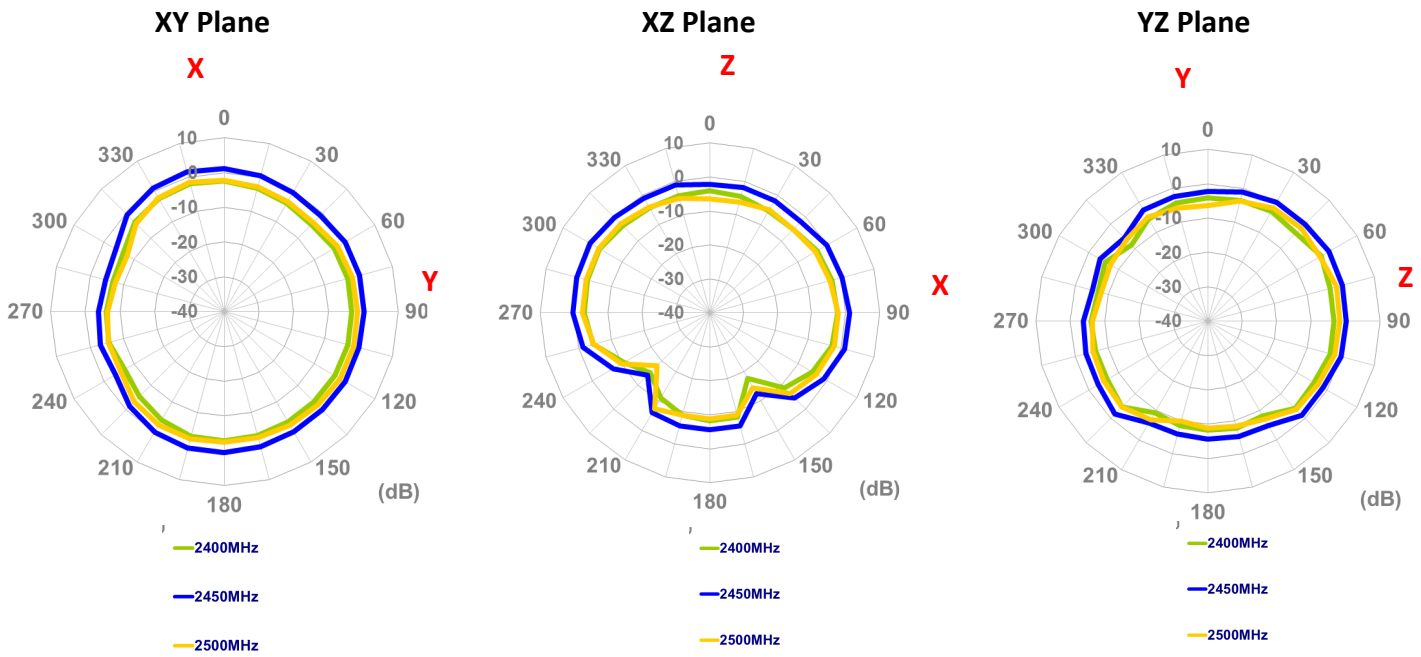

## 4.3 3D Radiation Pattern

2450 MHz

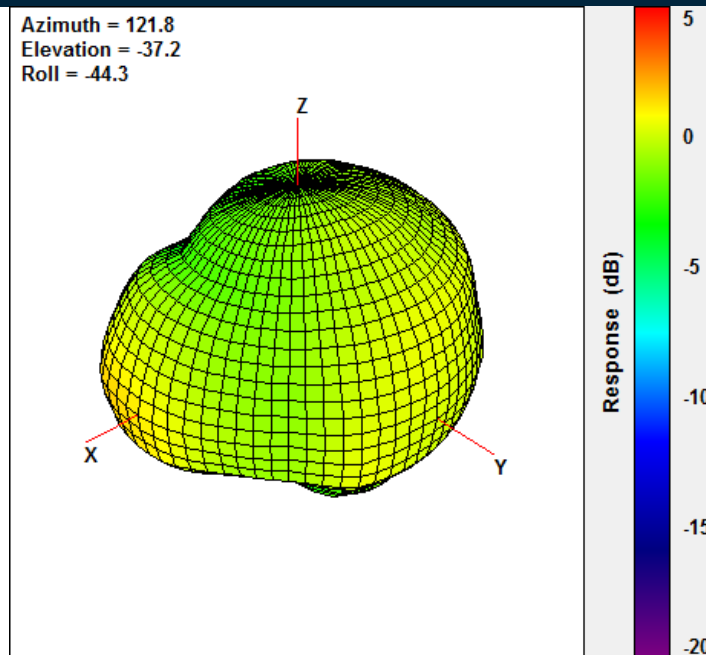

# 5. Mechanical Drawing – Antenna

## 5.1 Antenna Dimension and Drawing

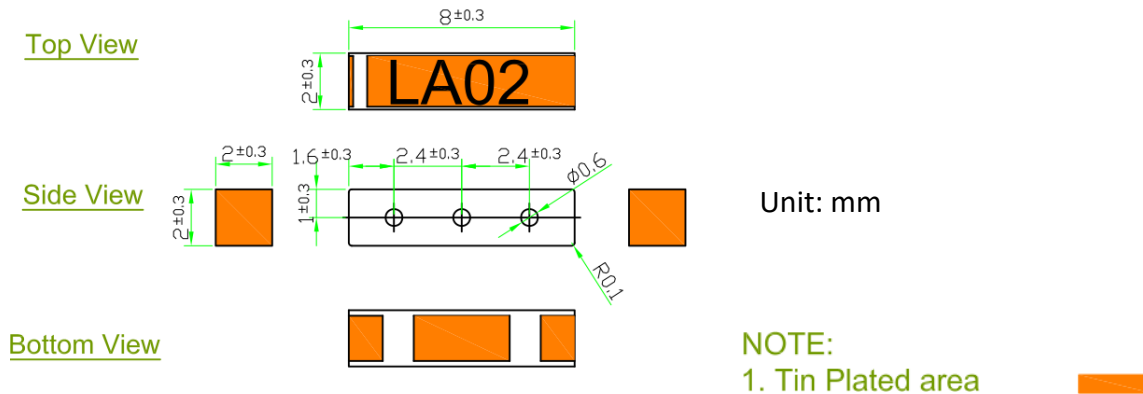

## 5.2 Antenna Footprint

Top Copper:

Pads 1 and 3 are the same size, Pads 4, 5 are the same size.  
Pad 1, 3, 5 should be connected to Ground. Pad 1 should be connected to a 50 ohm transmission line.

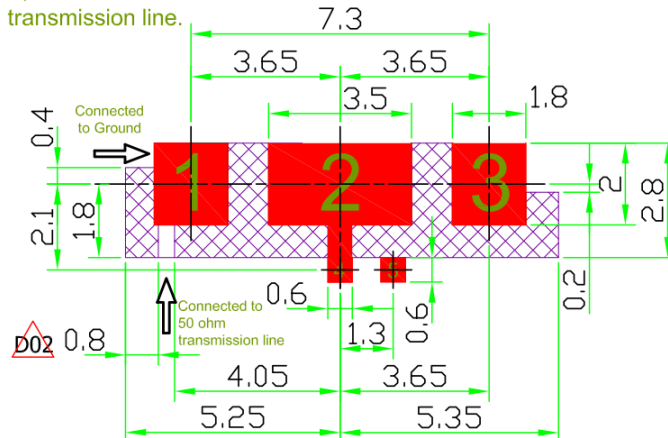

Top Solder Paste:

Pads 1 and 3 are the same size, Pads 4, 5 are the same size.

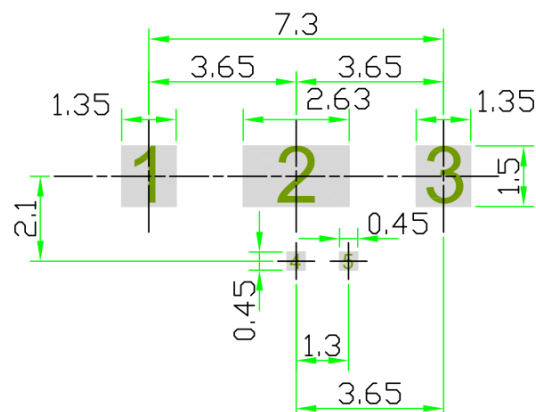

Top Solder Mask:

Pads 1 and 3 are the same size, Pads 4, 5 are the same size.  
This drawing is a negative of solder mask. Black regions are anti-mask.

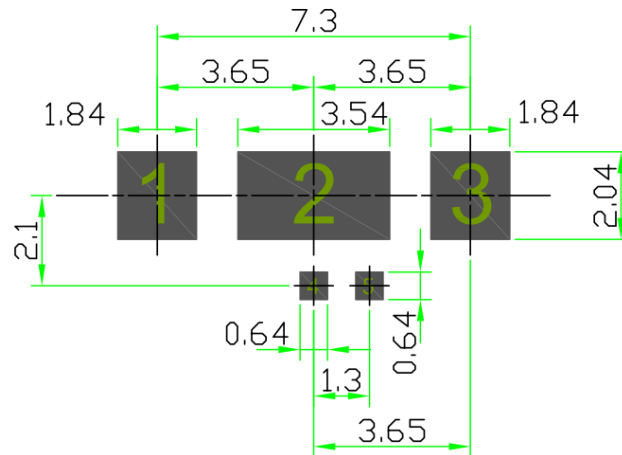

Composite Diagram:

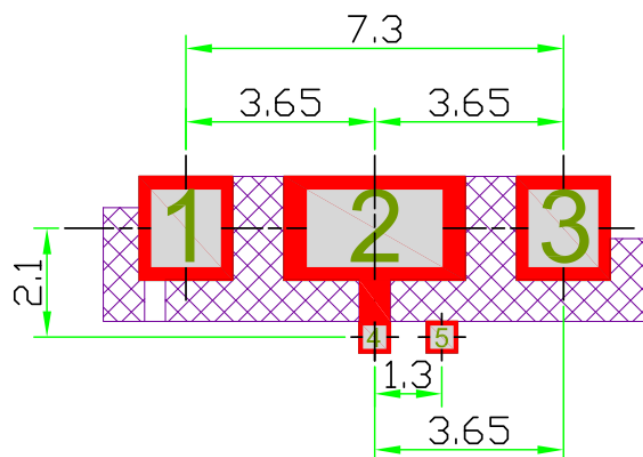

NOTE:

- 1. Tin Plated area
- 2. Solder Mask area
- 3. Copper area
- 4. Paste area
- 5. Copper Keepout area
- 6. Ground keepout should extend from top layer through all inner PCB layers to minimize coupling from RF feed to ground. The bottom PCB layer can be solid ground plane.
- 7. Any vias in pads should be either filled or tented to prevent solder from wicking away from the pad during reflow.
- 8. The dimension tolerances should follow standard PCB manufacturing guidelines
- 9. Pads 4 and 5 are reserved and typically not populated.

\*Taoglas is able to provide CAD drawing file to customers for evaluation.

## 5.2 Matching Circuit

Like all antennas, surrounding components, enclosures, and changes to the GND plane dimensions can alter performance. A pi-matching network like the one shown below is required in case adjustments need to be made. The antenna evaluation board (EVB) has a similar matching network. The components on the EVB are a good starting point for a new design, but will need to be adjusted upon integration to as close as possible to 50 Ohm impedance for best performance. The zero ohm resistor is needed for the ability to solder down a coax pigtail to make measurements with a vector network analyzer. Contact your regional Taoglas sales office for support.

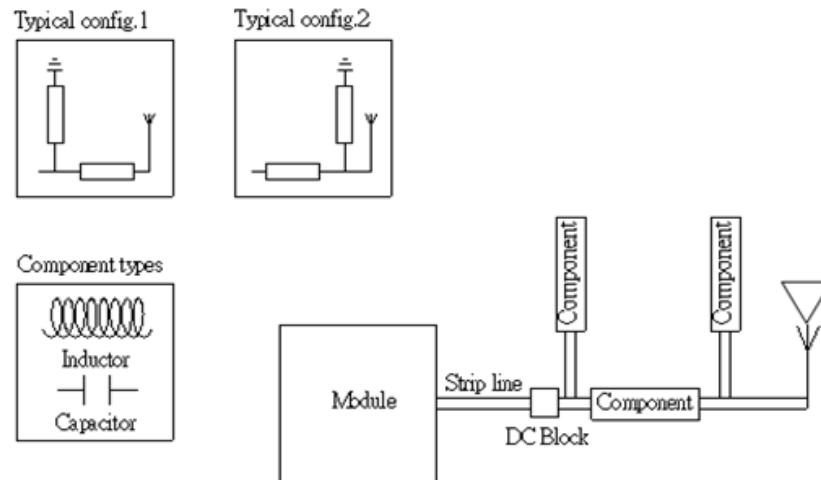

The matching network has to be individually designed using one, two or three components.

## 6. Mechanical Drawing – Evaluation Board

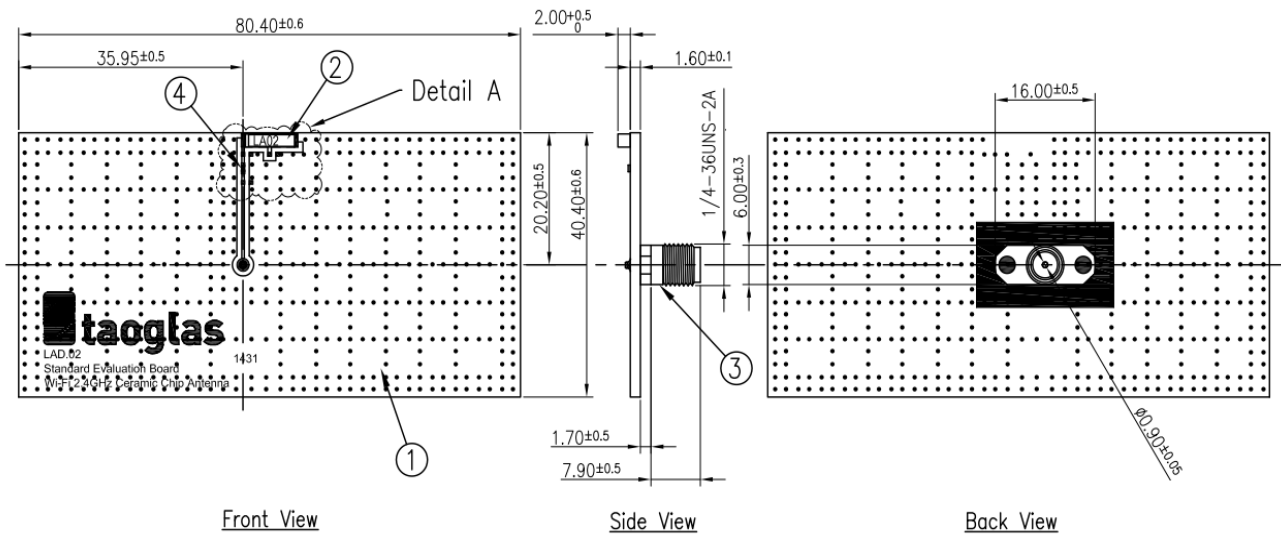

**NOTES:**

1. Solder Area
2. Logo & Text Ink Printing : White
3. Copper
4. Matching Component

	Name	P/N	Material	Finish	QTY
1	LAD.02_EVB Board	100214H000007A	FR4 1.6t	Black	1
2	LA.02 Chip Antenna	001514L000007A	Ceramic	N/A	1
3	SMA(F) ST	200411I000007A	Brass	Gold Plated	1
4	Resistor 0Ω (0402)	001514L010007A	Ceramic	N/A	1

Footprint on Taoglas Evaluation board (Unit: mm)

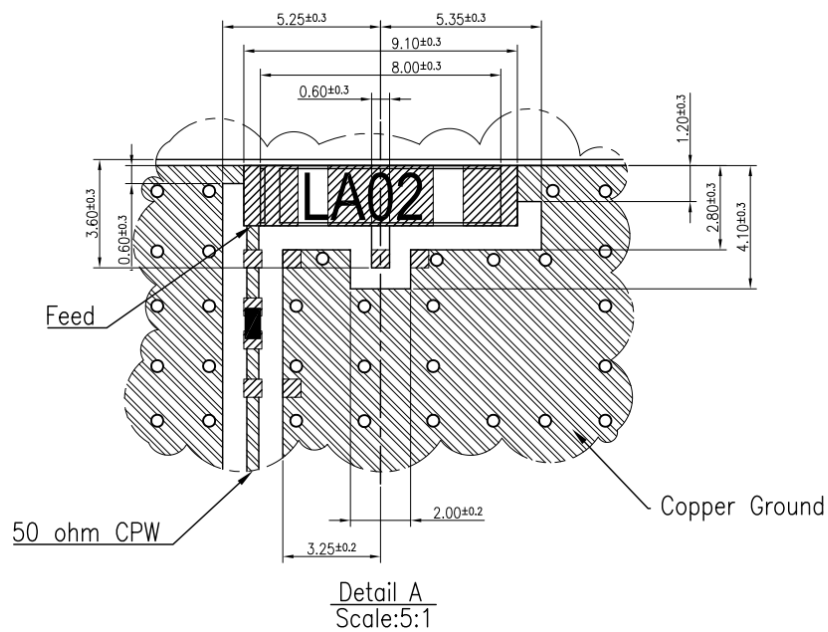

## 7. Soldering Conditions

Typical Soldering profile for lead-free process:

Phase	Profile features	Pb-Free Assembly (SnAgCu)
<b>PREHEAT</b>	-Temperature Min( $T_{smin}$ ) -Temperature Max( $T_{smax}$ ) -Time( $t_s$ ) from ( $T_{smin}$ to $T_{smax}$ )	150°C 200°C 60-120 seconds
<b>RAMP-UP</b>	Avg. Ramp-up Rate ( $T_{smax}$ to $T_P$ )	3°C/second(max)
<b>REFLOW</b>	-Temperature( $T_L$ ) -Total Time above $T_L$ ( $t_L$ )	217°C 30-100 seconds
<b>PEAK</b>	-Temperature( $T_P$ ) -Time( $t_p$ )	260°C 5-10 second
<b>RAMP-DOWN</b>	Rate	6°C / second max.
Time from 25°C to Peak Temperature		8 minutes max.
Composition of solder paste		96.5Sn/3Ag/0.5Cu
Solder Paste Model		SHENMAO PF606-P26

The graphic shows temperature profile for component assembly process in reflow ovens

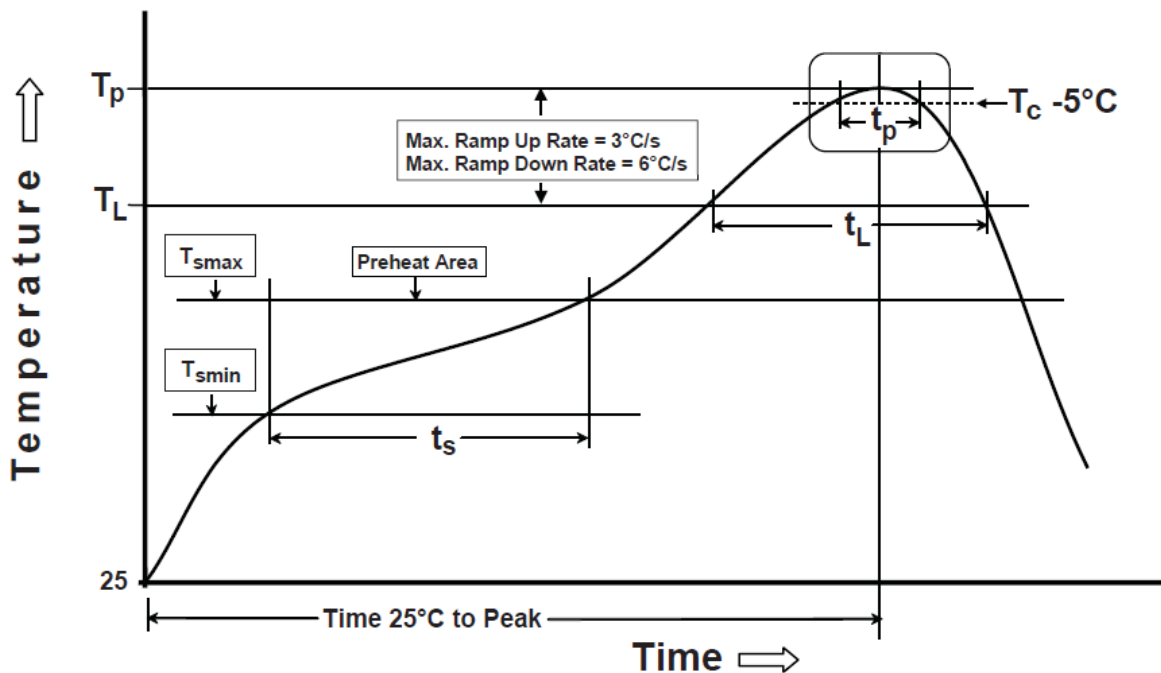

## 9. Packaging

IEC 286-3 : Polyester Blister Tape Reel  
 2,000 Pieces LA.02  
 Dimensions - Diameter 330\*18mm  
 Weight - 650g

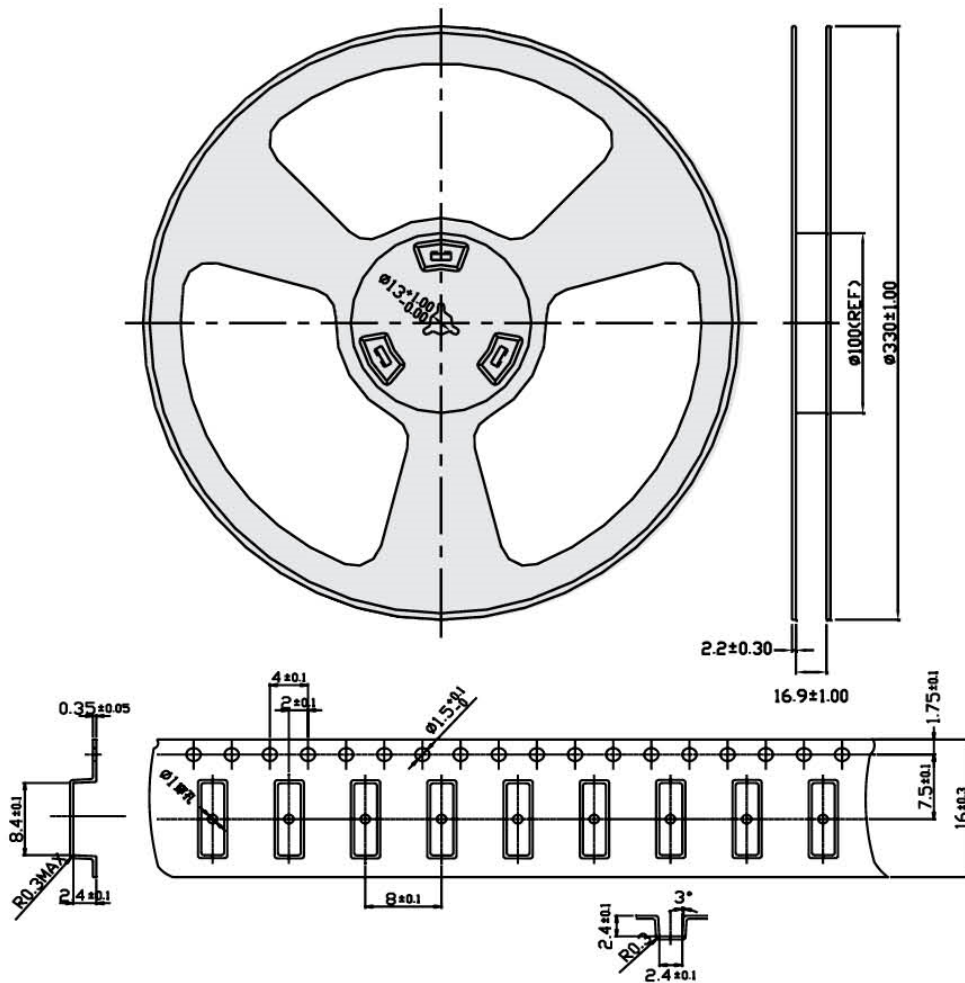

1 pc reel in small inner box  
 Dimensions - 350\*340\*47mm  
 Weight - 1Kg

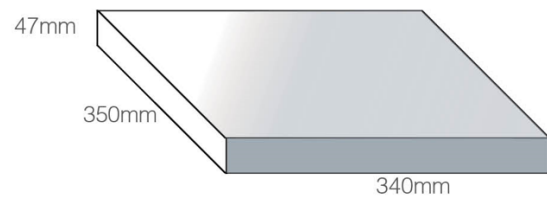

5 Reels / 10,000 pcs in one carton  
 Carton Dimensions - 360\*370\*275mm  
 Weight - 6Kg

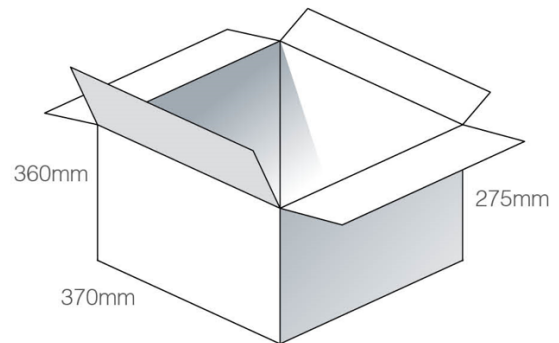

Pallet Dimensions 1100\*1100\*1550mm  
 45 Cartons per Pallet  
 9 Cartons per layer  
 5 Layers

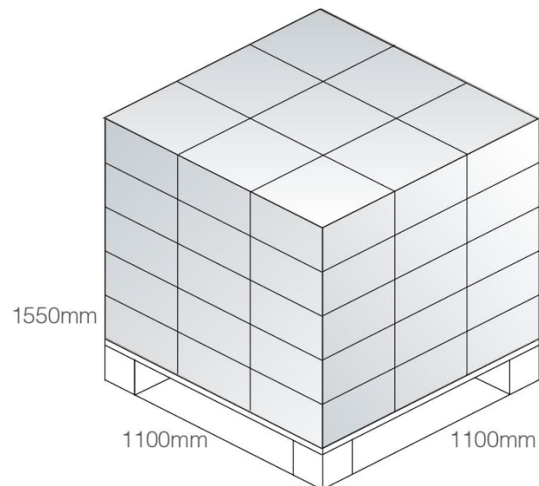

Unit: mm

Changelog for the datasheet

**SPE-15-8-040 – LA.02**

**Revision: C (Current Version)**

Date:	2021-11-1
Changes:	Format Change, MSL
Changes Made by:	Erik Landi

**Previous Revisions**

**Revision: B**

Date:	2021-05-18
Changes:	Amended Footprint drawing
Changes Made by:	Erik Landi

**Revision: A (Original First Release)**

Date:	2016-06-17
Notes:	Initial Release
Author:	STAFF



**TAOGLAS**®

[www.taoglas.com](http://www.taoglas.com)

