

Dual monolithic switching regulator with LDO and HSD

Data brief

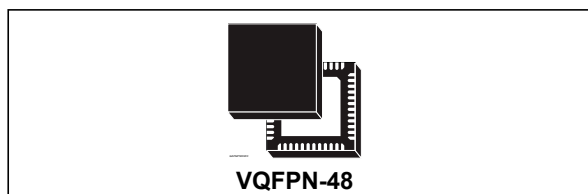

- Independent thermal protection on all regulators
- Independent current limit on all regulators
- Extremely low quiescent current in standby conditions
- Power good / adjustable voltage detector outputs to realize customized power up/down sequences

Features

- Two step-down synchronous switching voltage regulators with internal power switches:
 - Wide input voltage range (from 3.5 V to 26 V)
 - Internal high-side/ low-side NDMOS
 - 1 V minimum output
 - 3.0 A load current (max capability of each regulator)
 - 250 kHz free-run frequency
 - 250 kHz <math>f < 2\text{ MHz}</math> synchronization range
 - Integrated soft-start
 - Independent hardware enable pins
 - Independent power supply
 - 180° PWM output phase shift
 - Programmable switching frequency divider by 1, 2, 4 or 8 between the two DC/DC regulators
 - Power good function
- One standby / linear regulator
 - Output voltage programmable with external resistor divider
 - 250 mA maximum current capability
 - Backup function
 - Power good function
- One high side driver
 - 0.5 V max drop @ 0.5 A
 - Protected against short to ground and battery, loss of ground and battery, un-supplied short to battery
- Programmable under voltage battery detector
 - Under voltage threshold adjustable through dedicated pin (VDIN)
- Load dump protection

Description

L5963Q is a dual step-down switching regulator with internal power switches, high side driver and a low drop-out linear regulator that can operate as standby regulator or normal LDO.

All the regulators can be connected directly to the vehicle battery. In addition to an adjustable voltage detector, voltage supervisors are available.

The two DC-DC converters can work in free-run condition or synchronize themselves to an external clock. DC/DCs' PWM outputs have a 180° phase shift.

The high operating frequency allowed by the synchronization input helps to reduce AM and FM interferences and grants the use of small and low cost inductors and capacitors.

This IC finds application in the automotive segment, where load dump protection and wide input voltage range are mandatory.

A slug-up package option is available for applications which require heatsink use.

In standby condition the device guarantees extremely low quiescent current (25 μA typical @ $-40\text{ }^\circ\text{C} < T < 85\text{ }^\circ\text{C}$).

Table 1. Device summary

Order code	Package	Packing
L5963Q-V0T	VQFPN-48	Tape & Reel
L5963Q-V0Y	VQFPN-48	Tray

Contents

1	Overview	3
2	Block diagram	4
3	Package information	5
	3.1 VFQFPN-48 (7x7x1.0 - opt. D) package information	5
4	Revision history	7

1 Overview

The L5963Q integrates two switching mode synchronous step down converters, a linearly regulated power supply, a protected high side driver and voltage detectors. To guarantee a robust operation, all the outputs have independent thermal protection and current limitation.

The two switching mode synchronous step-down converters employ voltage mode control and feed forward functions to provide good load regulation and line regulation. Each converter has its own enable. The users can adjust the output voltage of the two converters by an external resistor divider. If the converters need to work with a frequency different from the free running frequency, in order to consider EMC performance in system level, they can be synchronized to an external clock by applying it on the SYNCIN pin. The frequency should be higher than half of the free running frequency. If there are more than one L5963Q in the system they can work in Master-Slave configuration, to make sure all the L5963Q have the same operating frequency of the Master device. This Master-Slave function is implemented by a dedicated pin SYNCOUT which always gives the operating frequency of DC/DC1 (for details, see the next chapter).

A dedicated voltage detector is integrated in the first switching converter to monitor DC/DC1 output. When the output voltage of DC/DC1 goes above the threshold, SW1OK is released and goes back to high with configurable delay set by a capacitor on the SW1OKDLY pin.

The linear regulator can work as standby regulator with low I_q or as a non-standby regulator. Connecting its enable ENLDO to its supply VINLDO the regulator works as a standby regulator, while connecting ENLDO to signal lower than 5 V the regulator works as non-standby regulator, with higher load capability but also higher quiescent current.

In standby state, i.e. only the linear regulator is powered and works as a standby regulator, with a load below 100 μ A the device has a quiescent current of just 25 μ A.

The small drop-out voltage of the linear regulator allows its use with low operating supply voltage.

In many cases, the linear regulator has to provide voltages to devices which need the reset function, like a MCU: this is provided by the LDOOK output, that is pulled low when VOURLDO goes below a threshold. Once VOURLDO returns above that threshold, with a specified hysteresis, LDOOK goes back to high with a configurable delay set by a capacitor on pin LDOOKDLY.

The high side driver is enabled by a dedicated pin and has a very low drop-out voltage. Protection circuits, like independent thermal protection, OCP, OVP and some special protections (loss of GND, SPU, short to supply and so on), are implemented to make it very robust (see next chapter for details).

L5963Q also embeds a voltage monitor (VDOUT), adjustable by means of an external resistor divider, that can be used to sense the battery or other voltages in the system. Sensing voltage is fed to pin VDIN. For instance, VDOUT might be used to monitor the output of DC/DC2, realizing in this way the Power Good function for that block. VDOUT is pulled low when voltage on VDIN goes below the specified threshold. Once VDIN returns above that threshold, with a specified hysteresis, VDOUT goes back to high with a configurable delay set by a capacitor on pin LDOOKDLY

2 Block diagram

Figure 1. Block diagram

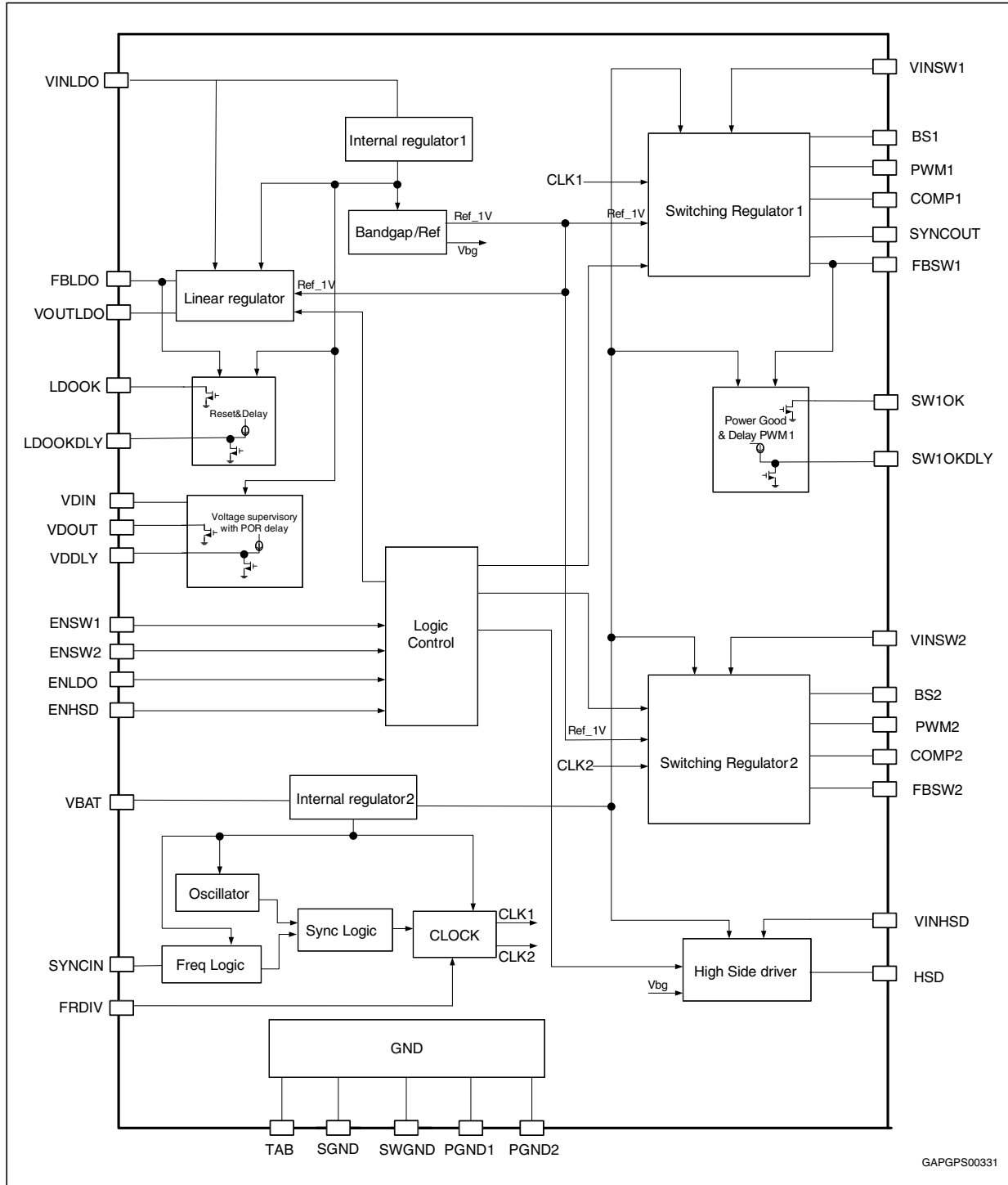

GAPGPS00331

3 Package information

In order to meet environmental requirements, ST offers these devices in different grades of ECOPACK[®] packages, depending on their level of environmental compliance. ECOPACK[®] specifications, grade definitions and product status are available at: www.st.com. ECOPACK[®] is an ST trademark.

3.1 VFQFPN-48 (7x7x1.0 - opt. D) package information

Figure 2. VFQFPN-48 (7x7x1.0 - opt. D) package outline

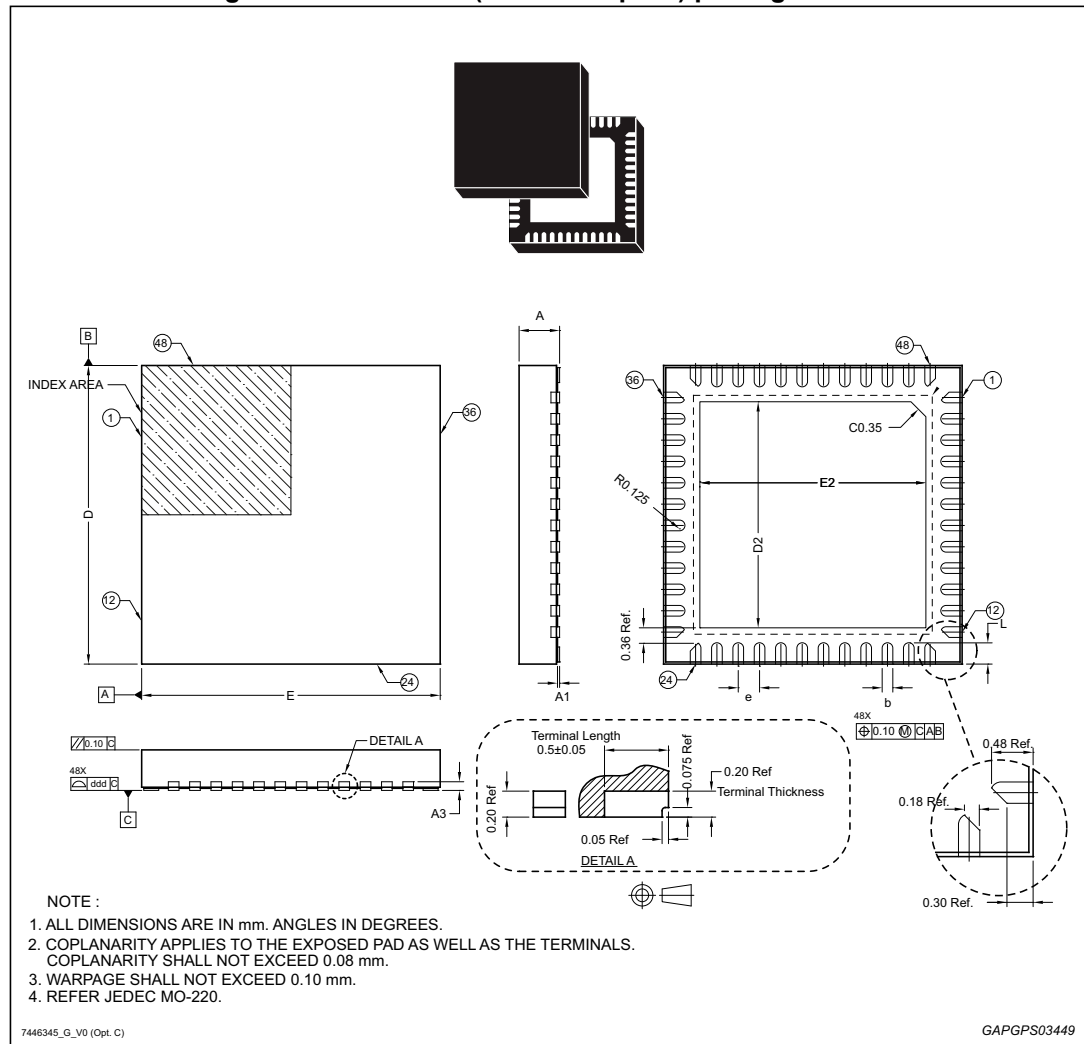

Table 2. VFQFPN-48 (7x7x1.0 - opt. D) package mechanical data

Ref	Dimensions					
	Millimeters			Inches ⁽¹⁾		
	Min.	Typ.	Max.	Min.	Typ.	Max.
A	0.85	0.95	1.05	0.0335	0.0374	0.0413
A1	-	-	0.05	-	-	0.0020
A2	-	0.75	-	-	0.0295	-
A3	-	0.200	-	-	0.0079	-
b	0.15	0.25	0.35	0.0059	0.0098	0.0138
D	6.80	7.00	7.15	0.2697	0.2756	0.2815
D2	5.15	5.30	5.45	0.2028	0.2087	0.2146
E	6.85	7.00	7.15	0.2697	0.2756	0.2815
E2	5.15	5.30	5.45	0.2028	0.2087	0.2146
e	0.45	0.50	0.55	0.0177	0.0197	0.0217
L	0.45	0.50	0.55	0.0177	0.0197	0.0217
ddd	-	-	0.08	-	-	0.0031

1. Values in inches are converted from mm and rounded to 4 decimal digits.

4 Revision history

Table 3. Document revision history

Date	Revision	Changes
10-Feb-2016	1	Initial release.

IMPORTANT NOTICE – PLEASE READ CAREFULLY

STMicroelectronics NV and its subsidiaries (“ST”) reserve the right to make changes, corrections, enhancements, modifications, and improvements to ST products and/or to this document at any time without notice. Purchasers should obtain the latest relevant information on ST products before placing orders. ST products are sold pursuant to ST’s terms and conditions of sale in place at the time of order acknowledgement.

Purchasers are solely responsible for the choice, selection, and use of ST products and ST assumes no liability for application assistance or the design of Purchasers’ products.

No license, express or implied, to any intellectual property right is granted by ST herein.

Resale of ST products with provisions different from the information set forth herein shall void any warranty granted by ST for such product.

ST and the ST logo are trademarks of ST. All other product or service names are the property of their respective owners.

Information in this document supersedes and replaces information previously supplied in any prior versions of this document.

© 2016 STMicroelectronics – All rights reserved